

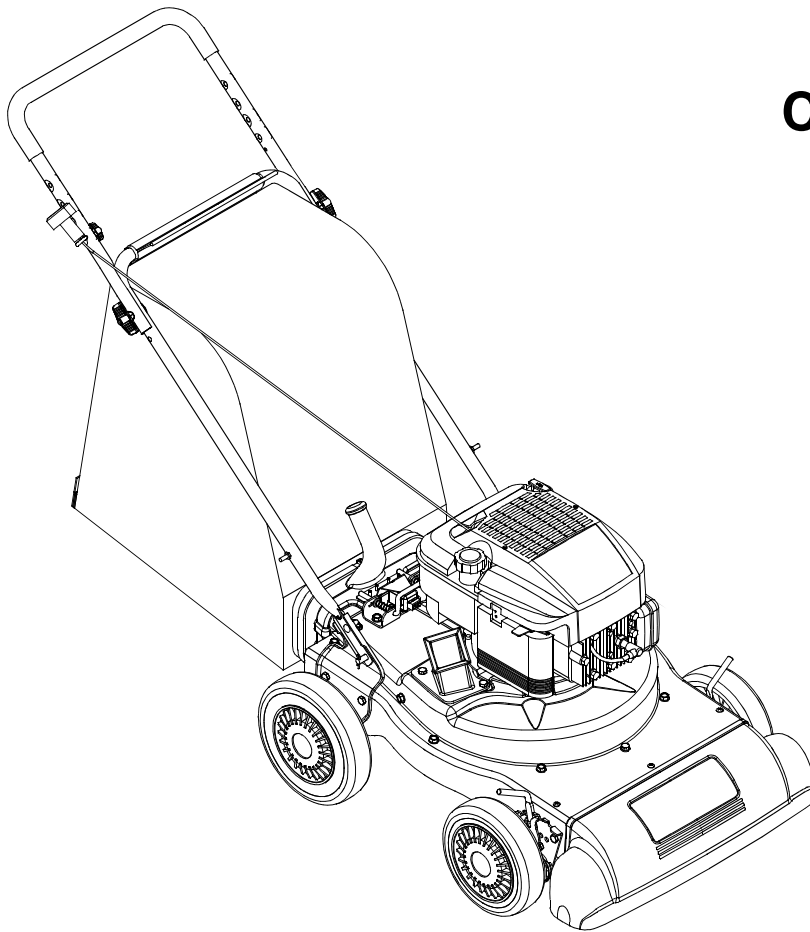

# OPERATOR'S MANUAL



**Chipper Shredder  
Vacuum  
Model Number  
24A-030E100**

## **IMPORTANT: READ SAFETY RULES AND INSTRUCTIONS CAREFULLY**

**Warning:** This unit is equipped with an internal combustion engine and should not be used on or near any unimproved forest-covered, brush-covered or grass-covered land unless the engine's exhaust system is equipped with a spark arrester meeting applicable local or state laws (if any). If a spark arrester is used, it should be maintained in effective working order by the operator. In the State of California the above is required by law (Section 4442 of the California Public Resources Code). Other states may have similar laws. Federal laws apply on federal lands. A spark arrester for the muffler is available through your nearest engine authorized service dealer or contact the service department, P.O. Box 368023 Cleveland, Ohio 44136-9722.

**CUB CADET CORP. P.O. BOX 368023 CLEVELAND, OHIO 44136-9722**

PRINTED IN U.S.A.

FORM NO. 770-10231A  
(2/00)

## TABLE OF CONTENTS

Content	Page
Important Safe Operation Practices.....	3
Assembling Your Chipper Shredder Vacuum .....	5
Know Your Chipper Shredder Vacuum .....	7
Operating Your Chipper Shredder Vacuum .....	8
Maintaining Your Chipper Shredder Vacuum.....	9
Troubleshooting.....	12
Parts List.....	14

## FINDING MODEL NUMBER

This Operator's Manual is an important part of your new chipper shredder vacuum. It will help you assemble, prepare and maintain the unit for best performance. Please read and understand what it says.



**Before you start assembling your new equipment**, please locate the model plate on the equipment and copy the information from it in the space provided below. The information on the model plate is very important if you need help from our Customer Support Department or an authorized dealer.

- You can locate the model number by looking down at the rear of the chipper shredder vacuum. A sample model plate is explained below. For future reference, please copy the model number and the serial number of the equipment in the space below.

_____	_____
(Model Number)	(Serial Number)
	
<b>CUB CADET CORP.</b>	
P.O. BOX 368023	
CLEVELAND, OHIO 44136	

Copy the model number here: \_\_\_\_\_

Copy the serial number here: \_\_\_\_\_

## CALLING CUSTOMER SUPPORT

If you have difficulty assembling this product or have any questions regarding the controls, operation or maintenance of this unit, please call the Customer Dealer Referral Line.



Call **1-(800)-528-1009** to reach the Customer Dealer Referral Line. Please have your unit's model number and serial number ready when you call. See previous section to locate this information.

For more details about proper lawn care, visit our website at [www.cubcadet.com](http://www.cubcadet.com)

---

## SECTION 1: IMPORTANT SAFE OPERATION PRACTICES



**WARNING:** This symbol points out important safety instructions which, if not followed, could endanger the personal safety and/or property of yourself and others. Read and follow all instructions in this manual before attempting to operate this machine. Failure to comply with these instructions may result in personal injury. When you see this symbol - **heed its warning**.

**WARNING:** The Engine Exhaust from this product contains chemicals known to the State of California to cause cancer, birth defects or other reproductive harm.

**DANGER:** This machine was built to be operated according to the rules for safe operation in this manual. As with any type of power equipment, carelessness or error on the part of the operator can result in serious injury. This machine is capable of amputating hands and feet and throwing objects. Failure to observe the following safety instructions could result in serious injury or death.

### GENERAL OPERATION

- Read this operator's manual carefully in its entirety before attempting to assemble this machine. Read, understand, and follow all instructions on the machine and in the manual(s) before operation. Be completely familiar with the controls and the proper use of this machine before operating it. Keep this manual in a safe place for future and regular reference and for ordering replacement parts.
- This machine is a precision piece of power equipment, not a plaything. Therefore, exercise extreme caution at all times. Your unit has been designed to chip, shred, vacuum, or blow. Do not use it for any other purpose.
- Never allow children under 16 years old to operate this machine. Children 16 years old and over should read and understand the operation instructions and safety rules in this manual and should be trained and supervised by an adult. Only responsible individuals who are familiar with these rules of safe operation should be allowed to use this machine.
- Thoroughly inspect the area where the equipment is to be used. Remove all stones, sticks, wire, bones, toys, and other foreign objects which could be tripped over or picked up and thrown by the chipper shredder vacuum in any direction which could cause serious personal injury to the operator or any others allowed in the area.
- Always wear safety glasses or safety goggles during operation or while performing an adjustment or repair, to protect eyes from foreign objects that may be thrown from the machine in any direction.
- Wear sturdy, rough-soled work shoes and close-fitting slacks and shirts. Shirts and pants that cover the arms and legs and steel-toed shoes are recommended. Never operate a unit in bare feet, sandals, slippery or light weight (e.g. canvas) shoes.
- Never place your hands or any part of your body or clothing near rotating parts. Keep clear of the discharge opening at all times. Never insert your hands or any part of your body or clothing into the nozzle, chipper chute or discharge opening as the rotating impeller can cause serious injury.
- Do not operate this machine while under the influence of alcohol or drugs.
- If it is necessary for any reason to unclog the feed intake or discharge openings or to inspect or repair any part of the machine where a moving part can come in contact your body or clothing, stop the machine, allow it to cool, disconnect the spark plug wire from the spark plug and ground against the engine before attempting to unclog, inspect or repair.
- Never operate unit without the vacuum bag or blower chute properly affixed to unit. To avoid a thrown object the large open end of bag must be securely closed prior to operation to prevent objects from being thrown out of the bag.
- If operating in the blower mode (optional blower chute attachment may be included with your unit):
  - Do not stand or walk in front of blower discharge or aim it at bystanders, pets, vehicles, ect. Objects thrown out the discharge can cause personal injury or property damage.
  - Do not direct blower discharge against a wall or other vertical obstructions. Discharge materials may ricochet back at the operator.
  - Adjust vac nozzle height to highest position to reduce likelihood of heavier objects (e.g., small stones, pieces of glass or metal) being picked up and thrown out the discharge. Raising nozzle to highest position also maximizes air intake for improved blowing performance.
- Never attempt to remove or empty vacuum bag when engine is running. Shut the engine off and wait for the impeller to come to a complete stop before removing the bag. The impeller continues to rotate for a few seconds after the engine is shut off. Never place any part of the body in the impeller area until you are sure the impeller has stopped rotating.
- Keep all guards and safety devices in place and operating properly.

- Do not allow an accumulation of processed material to build up in the discharge area as this will prevent proper discharge.
- When feeding material into the chipper, do not stand with your face or body directly in front of the chipper chute. Stand to one side. Material being feed may bounce back out of the chute and cause personal injury.
- If the cutting mechanism strikes a foreign object or if your machine should start making an unusual noise or vibration, immediately stop the engine, wait for impeller to come to a complete stop, and disconnect the spark plug wire and ground against the engine.

Follow steps listed below:

- Inspect for damage.
- Repair or replace any damaged parts prior to continuing operation.
- Check for any loose parts and tighten to assure continued safe operation.
- Muffler and engine become hot and can cause a burn. Do not touch.
- Only use parts and accessories made for this machine by the manufacturer. Failure to do so, can result in personal injury.
- If situations occur which are not covered in this manual, use care and good judgment. Contact your dealer for assistance. Telephone 1-800-800-7310 for the name of your nearest dealer.

## CHILDREN

Tragic accidents can occur if the operator is not alert to the presence of children. Children are often attracted to the chipping and vacuum activity. They do not understand the dangers. Never assume that children will remain where you last saw them.

- Keep children out of the work area and under the watchful care of a responsible adult other than the operator.
- Be alert and turn the machine off if a child enters the area.
- Before and while moving backwards, look behind and down for small children.
- Use extreme care when approaching blind corners, shrubs, trees, or other objects that may obscure your vision of a child who may run into the machine.
- Keep children away from hot or running engines. They can suffer burns from a hot muffler.
- Never allow children under age 16 to operate this machine. Children 16 years of age and over should read and understand the operation instructions and safety rules in this manual and should be trained and supervised by an adult.

## SAFE HANDLING OF GASOLINE:

To avoid personal injury or property damage use extreme care in handling gasoline. Gasoline is extremely flammable and the vapors are explosive. Serious personal injury can occur when gasoline is spilled on yourself or your clothes which can ignite. Wash your skin and change clothes immediately.

- Use only an approved gasoline container.
- Extinguish all cigarettes, cigars, pipes, and other sources of ignition.
- Never fuel machine indoors because flammable vapors will accumulate in the area.
- Never remove gas cap or add fuel while the engine is running. Allow engine to cool at least two minutes before refueling.
- Never over fill fuel tank. Fill tank to no more than 1/2 inch below bottom of filler neck to provide space for fuel expansion.
- Replace gasoline cap and tighten securely.
- If gasoline is spilled, wipe it off the engine and equipment. Move unit to another area. Wait 5 minutes before starting the engine.
- Never store the machine or fuel container inside where there is an open flame, spark, or pilot light as on a gas water heater, space heater, furnace, clothes dryer or other gas appliances.
- To reduce fire hazard, keep the machine free of grass, leaves, or other debris build-up. Clean up oil or fuel spillage and remove any fuel soaked debris.
- Allow machine to cool at least 5 minutes before storing.

## GENERAL SERVICE

- Never run an engine indoors or in a poorly ventilated area. Engine exhaust contains carbon monoxide, an odorless and deadly gas.
- Before cleaning, repairing, or inspecting, make certain the impeller and all moving parts have stopped. Disconnect the spark plug wire and ground against the engine to prevent unintended starting.
- Keep all nuts, bolts, and screws tight to be sure the equipment is in safe working condition.
- Never tamper with safety devices. Check their proper operation regularly.
- After striking a foreign object, immediately stop the engine, disconnect the spark plug wire and ground against the engine. Thoroughly inspect the machine for any damage. Repair the damage before starting and operating.
- Do not change the engine governor setting or overspeed the engine.
- Maintain or replace safety and instruction labels, as necessary.



**WARNING - YOUR RESPONSIBILITY:** Restrict the use of this power machine to persons who read, understand and follow the warnings and instructions in this manual and on the machine.

**NOTE:** Not all safety labels shown may apply to your chipper shredder vacuum.

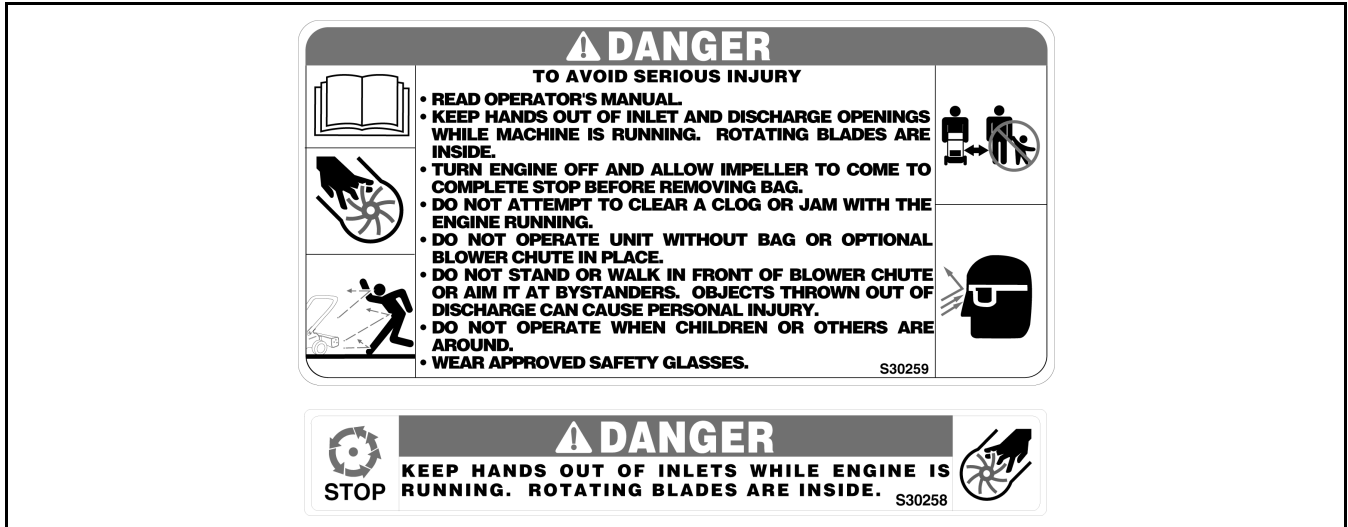

## SECTION 2: ASSEMBLING YOUR CHIPPER SHREDDER VACUUM

**IMPORTANT:** This unit is shipped without gasoline or oil in the engine. Be certain to service engine with gasoline and oil as instructed in the separate engine manual before operating your mower.

**NOTE:** Reference to right or left hand side of the chipper shredder vacuum is observed from the operating position.

### Removing Unit From Carton

- Remove staples, break glue on top flaps, or cut tape at carton end and peel along top flap to open carton.
- Remove loose parts if included with unit (i.e., operator's manual, etc.)
- Cut along corners, lay carton down flat, and remove packing material.
- Roll or slide unit out of carton and check carton thoroughly for loose parts.

### Loose Parts In Carton (See Figure 1)

- Handle Assembly
- Bag
- Blower Chute

### Disconnecting Spark Plug Wire

Before setting up your chipper shredder vacuum, disconnect the spark plug wire from the spark plug and ground to a stud on the engine.

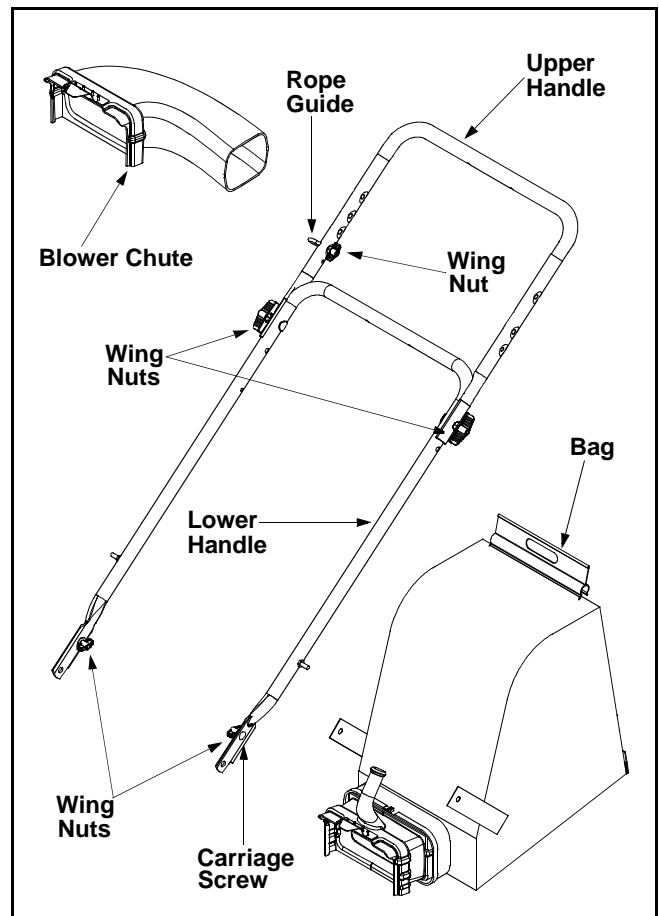

Figure 1

## Attaching The Handle

- Unfold the upper handle until it aligns with the lower handle.
- Secure the two handles by tightening the wing nuts (carriage bolts must be seated properly into the handle).
- Remove the hairpin clips from the handle brackets on the chipper shredder vacuum and remove the carriage bolts and wing nuts from the lower handle. See Figure 2.
- Place each bottom hole in lower handle over pins on handle brackets and secure with hairpin clips.
- Insert carriage bolts thru upper hole in lower handle from the outside and secure with wing nuts.

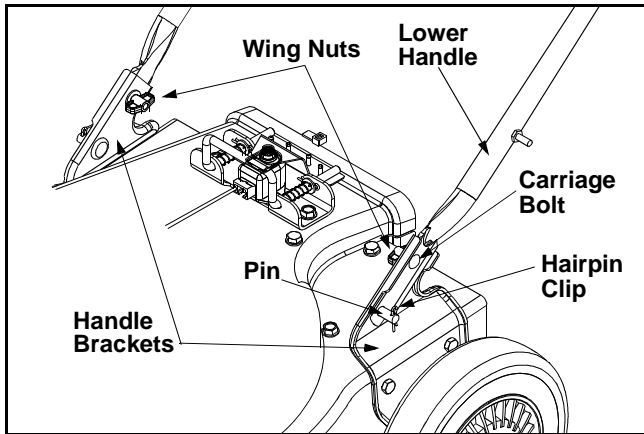

Figure 2

- Loosen the wing nut that secures the rope guide to the right side of upper handle.
- Pull the starter rope out of the engine slowly and slip the starter rope into the rope guide. Tighten the wing nut.

## Attaching The Bag

- Grasp bag handle with one hand and pull locking rod on mounting bracket with other hand toward engine. See Figure 3.
- Slip bag over the rim of the discharge opening and release locking rod to secure bag in place.
- Place the straps on the bag **over** the lower handle, hooking them on the studs.
- Snap bag clip to the top of the lower handle.

**NOTE:** The safety switch button attached to the mounting bracket must be fully depressed by the front tab on the bag handle when securing the bag or the engine will not start.

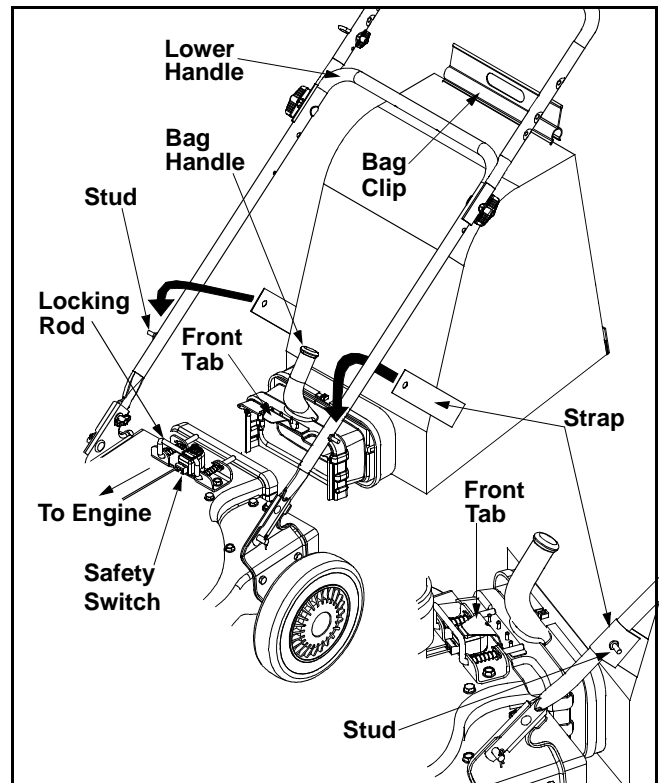

Figure 3

## Attaching The Blower Chute

- Grasp blower chute with one hand and pull locking rod on mounting bracket with other hand toward engine. See Figure 4.
- Slip blower chute over rim of the discharge opening and release locking rod to secure chute in place. Make sure the safety switch button is fully depressed by the front tab on the blower chute.
- Raise the nozzle height to the highest setting when using the blower chute. Refer to nozzle height adjustment in the OPERATION section.

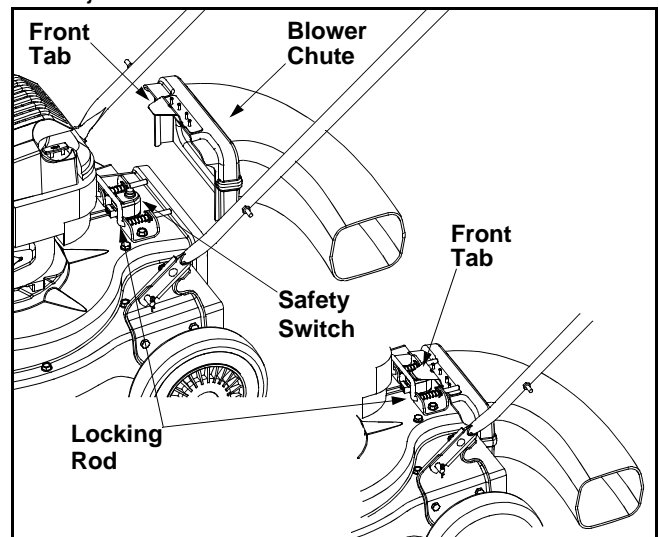

Figure 4

## SECTION 3: KNOW YOUR CHIPPER SHREDDER VACUUM

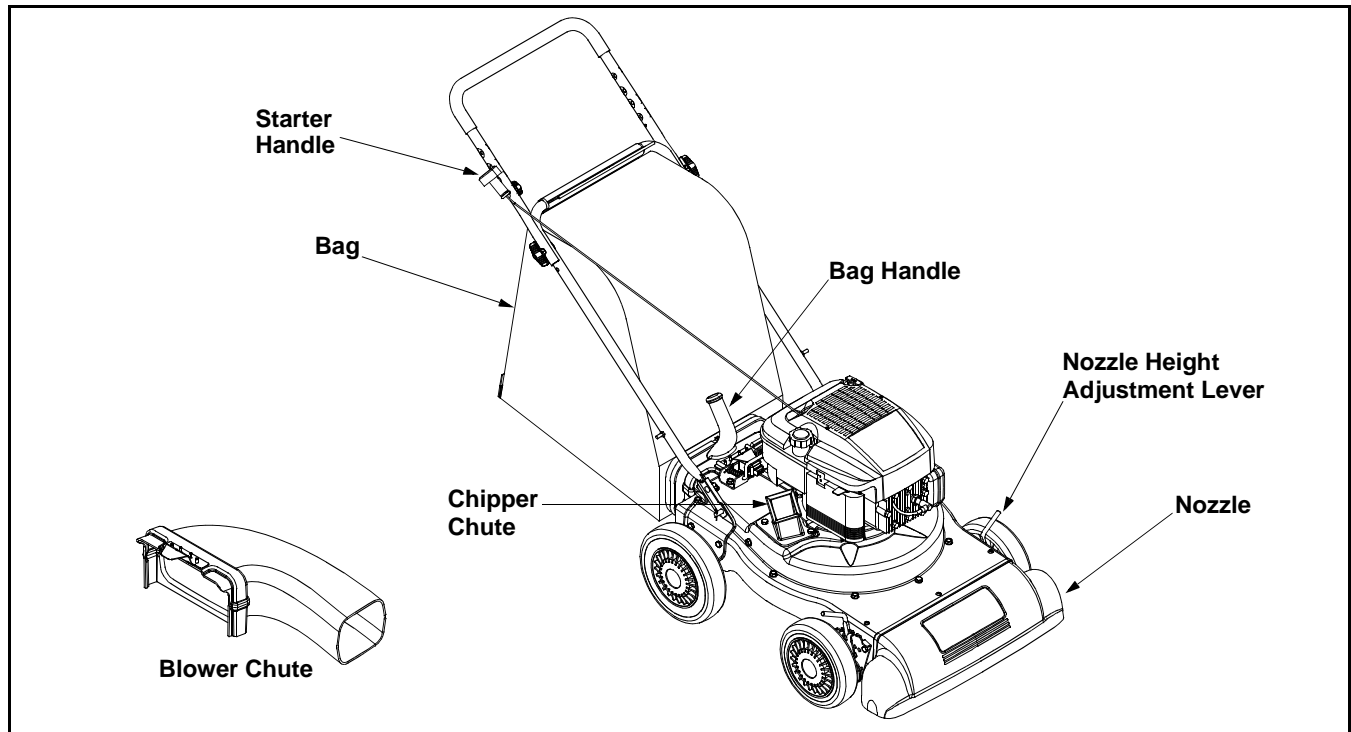

Figure 5

Read this operator's manual and safety rules before operating your chipper shredder vacuum. Compare the illustrations in Figure 5 with your unit to familiarize yourself with the location of various controls and adjustments. Save this manual for future reference.

### Starter Handle

The starter handle is attached to the right upper handle. Stand behind unit and pull the starter handle to start engine. See Figure 5.

### Bag

Collects shredded material fed through the chipper chute or vacuumed through the nozzle. See Figure 5.

### Bag Handle

Used to grasp bag in order to assist in attaching, removing, and emptying bag. See Figure 5.

### Chipper Chute

Allow twigs and small branches up to 1 1/2" in diameter to be fed into the impeller for chipping. See Figure 5.

### Blower Chute

When attached to unit the blower chute is used to blow or scatter yard waste such as leaves, pine needles, or small twigs across yard. See Figure 5.

### Nozzle Height Adjustment Lever

Used to adjust the nozzle ground clearance ranging approximately 5/8" to 3 3/4".

### Nozzle

Yard waste such as leaves and pine needles can be vacuumed up through the nozzle for shredding.

### Throttle Control Lever (Not Shown)

The throttle control lever is located on the engine. It controls the engine's speed and stops the engine. See separate engine manual packed with unit for details.

### Engine Controls

See the separate engine manual for the location and function of the controls on the engine.

## Stopping Engine

- Move throttle control lever to STOP or OFF position.
- Disconnect spark plug wire from spark plug and ground against the engine.

## SECTION 4: OPERATING YOUR CHIPPER SHREDDER VACUUM



**WARNING:** The operation of any chipper shredder vacuum can result in foreign objects being thrown into the eyes, which can damage your eyes severely. Always wear the safety glasses provided with this unit or eye shields before chipping or blowing and while performing any adjustments or repairs.

### Gas And Oil Fill-Up

Service the engine with gasoline and oil as instructed in the separate engine manual packed with your chipper shredder vacuum. Read instructions carefully.



**WARNING:** Never fill fuel tank indoors with engine running or until the engine has been allowed to cool for at least two minutes after running.

### Starting Engine

- Attach spark plug wire to spark plug. Make certain the metal cap on the end of the spark plug is fastened securely over the metal tip on the spark plug.
- Make sure safety switch wire is connected to engine and properly grounded.
- **Engines with choke lever:**  
Move choke lever on engine to CHOKE position. (A warm engine may not require choking).
- **Engines with primer:**  
Prime engine as instructed in separate engine manual.
- The throttle control is located on the engine. Move engine throttle control lever to FAST or ON position.
- Stand behind unit, grasp starter handle and pull rope out slowly until engine reaches start of compression cycle (rope will pull slightly harder at this point).
- Pull rope with a rapid, continuous, full arm stroke. Keep a firm grip on starter handle. Let rope rewind slowly.
- Repeat previous steps until engine fires. When engine starts, move choke control (if equipped) gradually to RUN position.



**WARNING:** Never run the engine indoors or in a poorly ventilated area. Engine exhaust contains carbon monoxide, an odorless and deadly gas.

### To Empty Bag

- Unhook bag straps from the lower handle and unsnap bag clip from the top of lower handle. See Figure 6.

- Grasp bag handle with one hand and pull lock rod on mounting bracket with other hand toward engine to release.
- Remove bag from rim of the discharge opening. Refer to Figure 3.
- Twist the two buttons on the back of the bag to unlock and empty contents. See Figure 6.
- Hold bag handle and bag clip while emptying the contents.

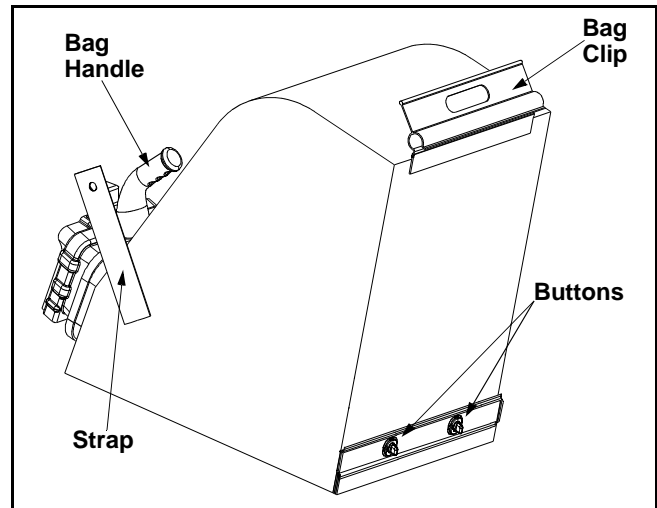

Figure 6

### To Remove Blower Chute

- Grasp blower chute with one hand and pull lock rod on mounting bracket with other hand toward engine to release. Refer to Figure 4.
- Remove blower chute from rim of the discharge opening.

### Using the Chipper Shredder Vacuum

Place both hands on top of upper handle to push unit over yard waste. Yard waste such as leaves and pine needles can be vacuumed up through the nozzle for shredding. After material has been shredded by the flail blades on the impeller assembly, it will be discharged into catcher bag or through blower chute. Do not attempt to shred or chip any material other than vegetation found in a normal yard (i.e. branches, leaves, twigs, ect.) Avoid fibrous plants such as tomato vines until they are thoroughly dried out. Materials such as stalks or heavy branches up to 1 1/2" in diameter may be fed into the chipper chute. See Figure 7.



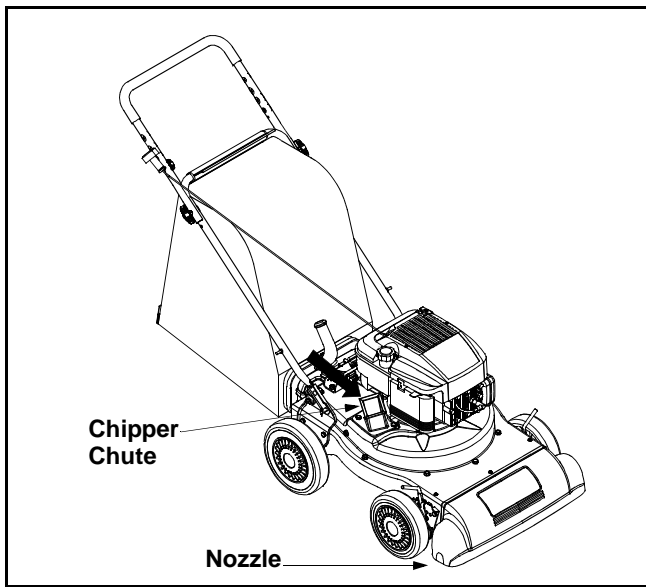

Figure 7

**IMPORTANT:** The flail screen is located inside the housing in the discharge area. If the flail screen becomes clogged, remove and clean as instructed in SECTION 5: MAINTAINING YOUR CHIPPER SHREDDER VACUUM. For best performance, it is also important to keep the chipper blade sharp.



**WARNING:** Do not at any time make any adjustments without first stopping engine and disconnecting spark plug wire.

## Nozzle Height Adjustment

The nozzle can be adjusted to any five positions, ranging from 5/8" to 3 3/4" ground clearance. The nozzle height has to be adjusted according to the conditions. Move the height adjustment levers forward or backward to adjust the nozzle upwards or downwards. See Figure 8.

**NOTE:** In general, raise the nozzle height to vacuum a thick layer of leaves or to operate with the blower chute and lower the nozzle height for smoother surfaces.

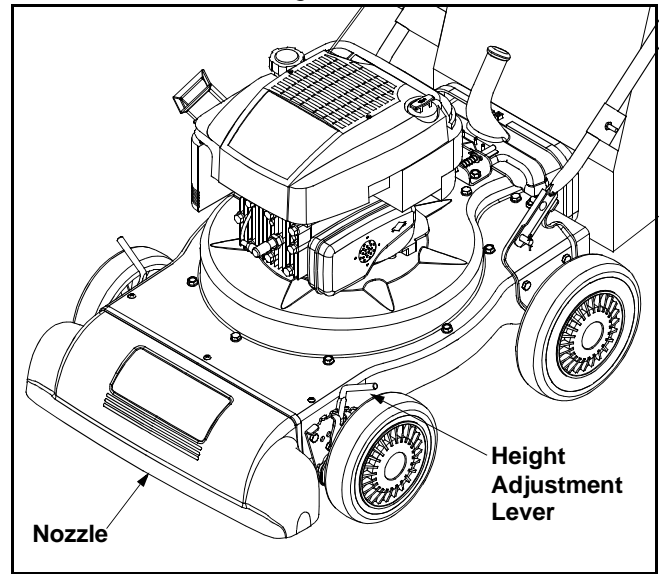

Figure 8

## SECTION 5: MAINTAINING YOUR CHIPPER SHREDDER VACUUM

### Customer Responsibilities

MAINTENANCE SCHEDULE		Before each use	Every 25 hours	Every 50 hours	Every 100 hours	Once a season	Before storage	SERVICE DATES					
PRODUCT	Lubricate Wheels					✓							
	Lubricate Nozzle Levers					✓							
	Lubricate Locking Rod					✓							
	Check Chipper Blade		✓			✓							
ENGINE	Change Oil		✓				✓						
	Check Air Filter		✓			✓							
	Clean Engine	✓					✓						
	Check Spark Plug			✓		✓							



**WARNING:** Always stop engine and disconnect spark plug wire before cleaning, lubricating or doing any kind of maintenance on your machine.

## Lubrication

**Wheels:** Lubricate each wheel shoulder screw once a season with light oil. See Figure 9.

**Nozzle height adjustment levers:** Lubricate the pivot points of the nozzle height adjustment levers once a season with light oil. See Figure 9.

**Engine:** Follow the separate engine manual packed with you unit for lubrication instructions.

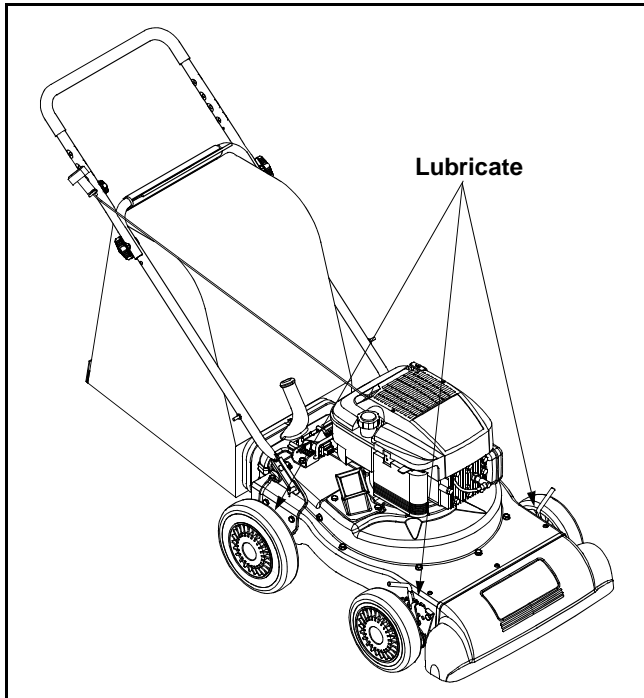

Figure 9

## Maintenance

### Engine

Refer to the separate engine manual for all engine maintenance instructions.

- Check **engine oil level** before each use as instructed in the separate engine manual packed with your unit. Read and follow instructions carefully.
- Clean **air cleaner** every 25 hours under normal conditions or once a season. Clean every few hours under extremely dusty conditions. To service the air cleaner, refer to the separate engine manual packed with your unit.
- The **spark plug** should be cleaned and the gap reset once a season. Check engine manual for correct plug type and gap specifications.

## Removing The Flail Screen

If the discharge area becomes clogged, remove the flail screen and clean area as follows:

- Stop the engine and make certain the chipper shredder vacuum has come to a complete stop.
- Disconnect spark plug wire from spark plug and ground against the engine.
- Remove the bag or blower chute from the unit as instructed in the OPERATION section to obtain access to flail screen. See Figure 10.

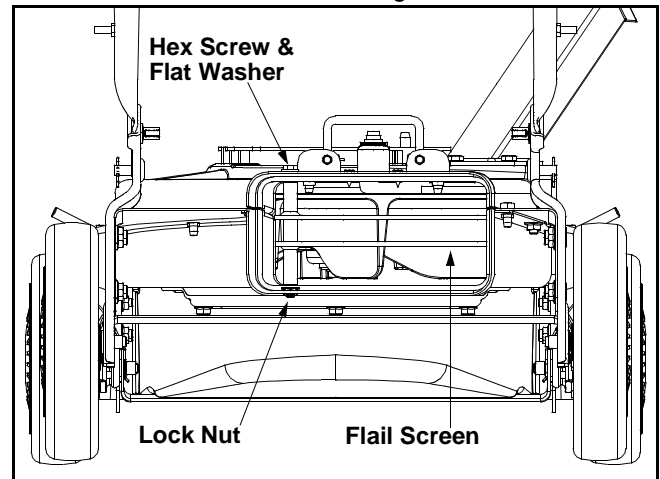

Figure 10

- Remove hex screw on right side of unit that attaches to the fail screen. See Figure 11.
- Remove hex screw and flat washer on top of rear housing mounting bracket and the lock nut that secures flail screen. See Figure 10.
- Remove and clean the screen by scraping or washing with water. Reinstall the flail screen.

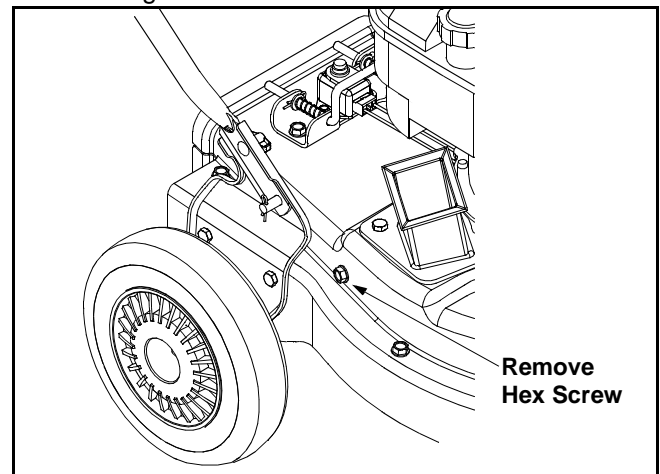

Figure 11

## Sharpening Or Replacing Chipper Blade

Because the engine on this unit has a tapered crankshaft, a special impeller tool (part number 753-0638) is required to remove the impeller assembly. For further assistance, contact your local service dealer.

**NOTE:** When tipping the unit, empty the fuel tank and keep spark plug side up.

- Disconnect the spark plug wire and ground it away from the spark plug.
- Remove the front hubcaps, shoulder screws, wave washers, and bell washers that attach to the front wheels. See Figure 12.
- Remove the shoulder screws that go through the pivot arms and height bracket adjusters to the front support brace.

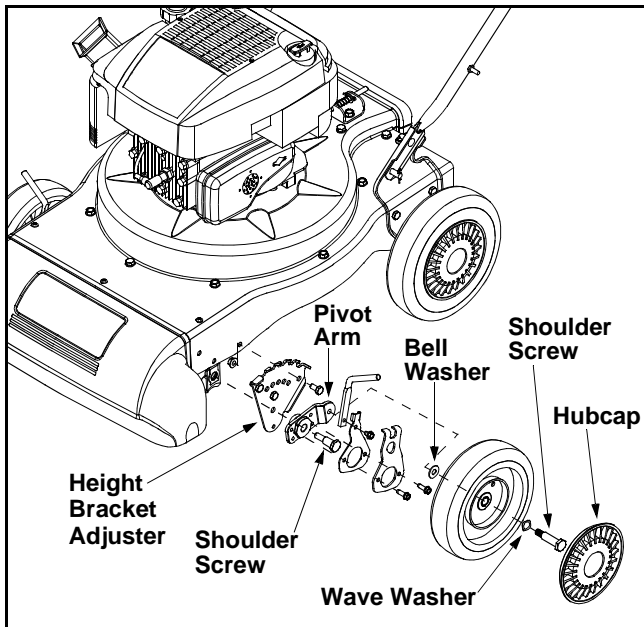

**Figure 12**

- Remove the three screws on the upper housing that secure the nozzle cover and the nine screws that secure the lower housing to the upper housing. See Figure 13.

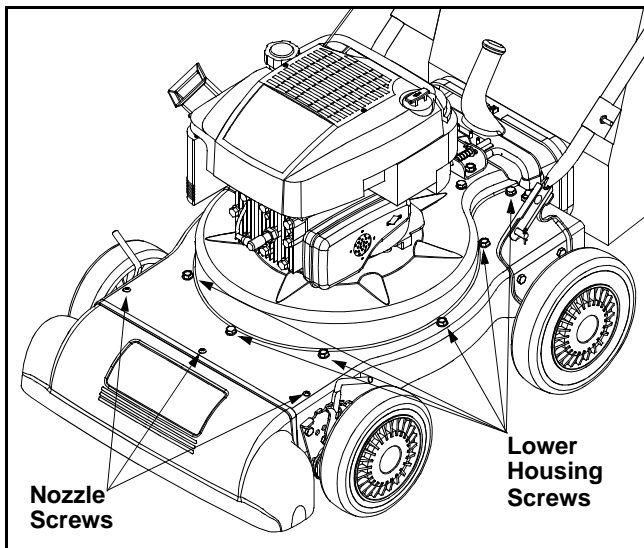

**Figure 13**

- Remove lock nut that secures flail screen to the lower housing. The flail screen does not have to be removed.
- Remove the hex bolt, lock washer, and flat washer that secure the impeller assembly to the crankshaft. See Figure 14.

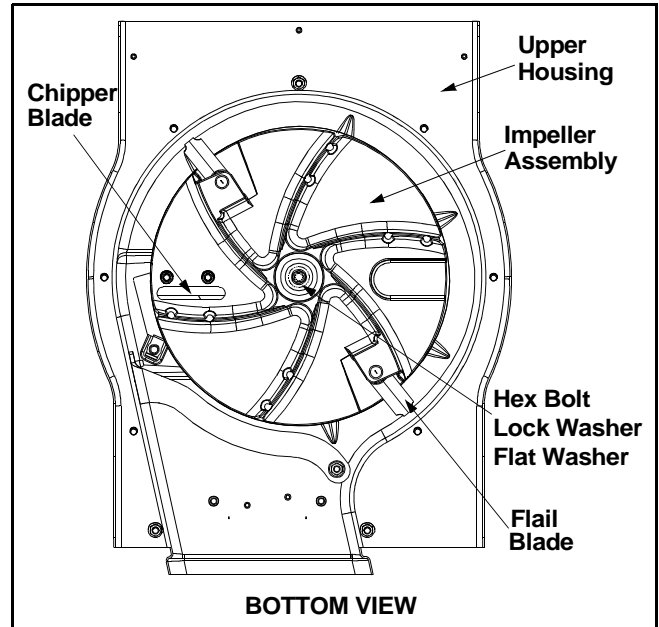

**Figure 14**

- Apply lubricant to the threads of impeller removal tool and then thread the tool into the crankshaft. Stop when the impeller assembly can move on the crankshaft.
- Remove the impeller assembly from the crankshaft. Unthread the impeller removal tool from the impeller assembly.
- Remove the blade using a 3/16" allen wrench on the outside of the blade and 1/2" wrench on the impeller assembly.
- Replace or sharpen chipper blade.
- When sharpening blade, protect hands by using gloves and follow the original angle of grind.
- Reassemble by performing the previous steps in reverse order.
- Tighten blade screws to 210-250 in-lbs. Tighten impeller bolt to 375-425 in-lbs.

### Storing Your Chipper Shredder Vacuum

- Clean the equipment thoroughly.
- Wipe equipment with a oiled rag to prevent rust.
- Refer to engine manual for correct engine storage instructions
- Store unit in a clean, dry area. Do not store next to corrosive materials such as fertilizer.

## SECTION 6: TROUBLESHOOTING

Problem	Cause	Remedy
Engine fails to start	<ol style="list-style-type: none"> <li>1. Spark plug wire disconnected.</li> <li>2. Fuel tank empty or stale fuel.</li> <li>3. Throttle control lever not in correct starting position. (If Equipped)</li> <li>4. Choke not in CHOKE position.</li> <li>5. Blocked fuel line.</li> <li>6. Faulty spark plug.</li> </ol>	<ol style="list-style-type: none"> <li>1. Connect wire to spark plug.</li> <li>2. Fill tank with clean, fresh gasoline.</li> <li>3. Move throttle lever to FAST position.</li> <li>4. Move choke to CHOKE position.</li> <li>5. Clean fuel line.</li> <li>6. Clean, adjust gap, or replace.</li> </ol>
Engine runs erratic	<ol style="list-style-type: none"> <li>1. Spark plug wire loose.</li> <li>2. Unit running on CHOKE.</li> <li>3. Blocked fuel line or stale fuel.</li> <li>4. Water or dirt in fuel system.</li> <li>5. Dirty air cleaner.</li> <li>6. Carburetor out of adjustment.</li> </ol>	<ol style="list-style-type: none"> <li>1. Connect and tighten spark plug wire.</li> <li>2. Move choke lever (if equipped) to OFF position.</li> <li>3. Clean fuel line; fill tank with clean, fresh gasoline</li> <li>4. Drain fuel tank. Refill with fresh fuel.</li> <li>5. Clean or replace air cleaner.</li> <li>6. See authorized service dealer.</li> </ol>
Too much vibration	<ol style="list-style-type: none"> <li>1. Loose parts or damaged impeller.</li> </ol>	<ol style="list-style-type: none"> <li>1. See authorized service dealer.</li> </ol>
Engine overheats	<ol style="list-style-type: none"> <li>1. Engine oil level low.</li> <li>2. Dirty air cleaner.</li> <li>3. Carburetor not adjusted properly.</li> </ol>	<ol style="list-style-type: none"> <li>1. Fill crankcase with proper oil.</li> <li>2. Clean or replace air cleaner.</li> <li>3. See authorized service dealer.</li> </ol>
Occasional skip (hesitates) at high speed	<ol style="list-style-type: none"> <li>1. Spark plug gap too close.</li> </ol>	<ol style="list-style-type: none"> <li>1. Adjust gap to .030".</li> </ol>
Unit does not discharge	<ol style="list-style-type: none"> <li>1. Discharge chute clogged.</li> <li>2. Foreign object lodged in impeller.</li> <li>3. Low engine RPM</li> <li>4. Vacuum bag is full.</li> </ol>	<ol style="list-style-type: none"> <li>1. Stop engine immediately and disconnect spark plug wire. Clean flail screen and inside of discharge opening.</li> <li>2. Stop engine and disconnect spark plug wire. Remove lodged object.</li> <li>3. Always run engine at full throttle.</li> <li>4. Empty bag.</li> </ol>
Rate of discharge slows considerably or composition of discharged material changes.	<ol style="list-style-type: none"> <li>1. Low engine RPM.</li> <li>2. Chipper blade dull.</li> </ol>	<ol style="list-style-type: none"> <li>1. Always run engine at full throttle.</li> <li>2. Replace chipper blade or see your authorized service dealer.</li> </ol>

**NOTE:** For repairs beyond the minor adjustments listed above, contact your nearest authorized service dealer.

# NOTES

# Model 24A-030E100

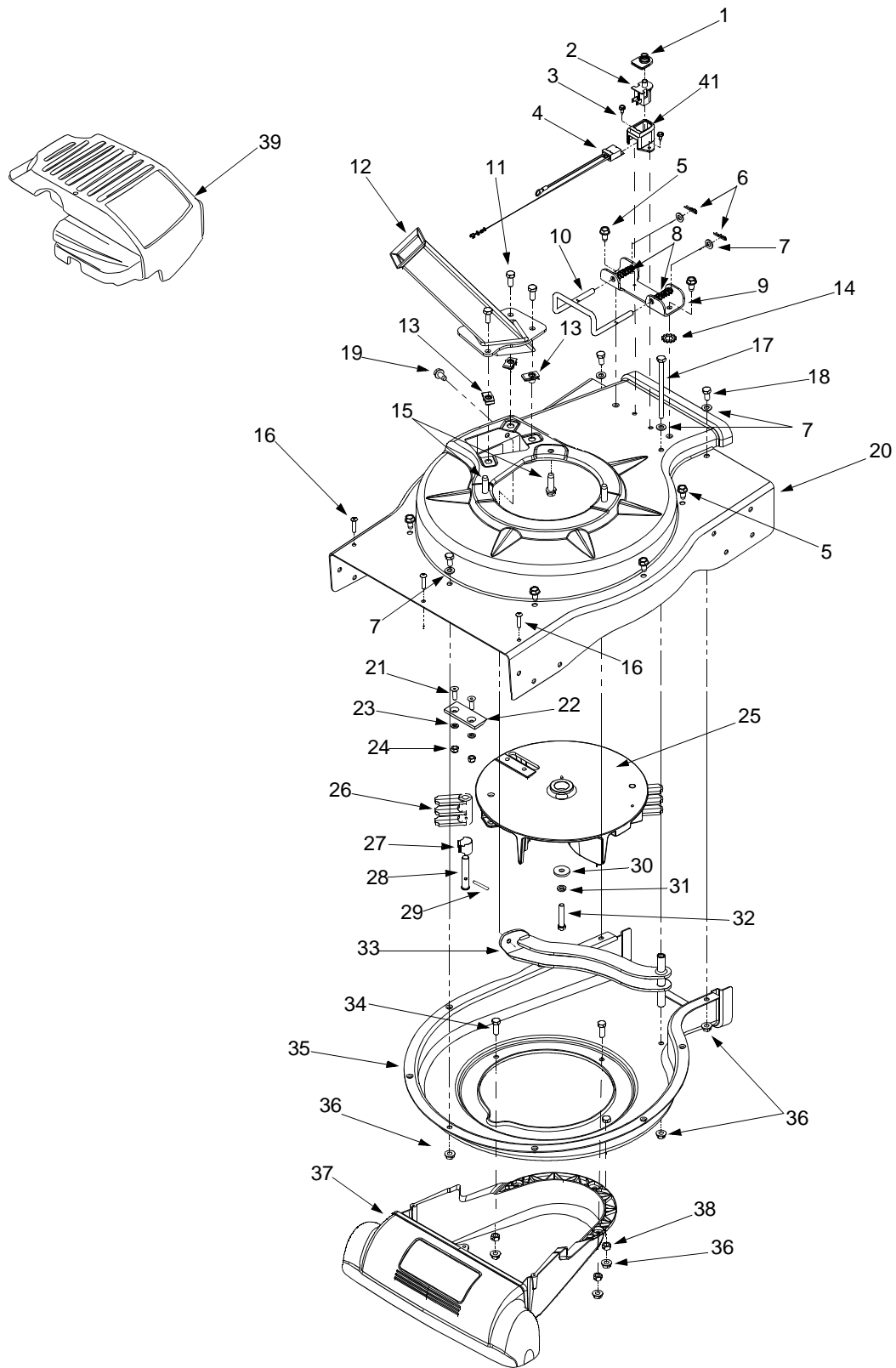

# Model 24A-030E100

Ref. No.	Part No.	Part Description	Ref. No.	Part No.	Part Description
1.	725-1700	Switch Cover	22.	781-0490	Chipper Blade
2.	725-3166	Safety Switch	23.	736-0119	Lock Washer 5/16
3.	710-0224	Hex Washer Screw #10-16 x .50	24.	712-0411	Hex Lock Nut 5/16-24
4.	629-0920	Wire Harness	25.	681-0152	Impeller Assembly
5.	710-0604	Hex Washer Screw 5/16-18 x .625	26.	719-0329	Flail Blade
6.	714-0104	Cotter Pin	27.	781-0735	Pin Clip
7.	736-0264	Flat Washer.330 ID x.630 OD	28.	711-1401	Clevis Pin
8.	732-0962	Compression Spring	29.	715-0166	Spiral Pin
9.	781-0778	Mounting Bracket	30.	736-0247	Flat Washer.375 ID x 1.25 OD
10.	747-1153	Lock Rod	31.	736-0217	Lock Washer 3/8
11.	710-3008	Hex Cap Screw 5/16-18 x .75	32.	710-0818	Hex Cap Screw 3/8-24 x 2.0
12.	681-0122	Chipper Chute Assembly	33.	681-0154	Screen Assembly
13.	726-0454	U-Clip Lock Nut 5/16-18	34.	710-3038	Hex Cap Screw 5/16-18 x .875
14.	736-0607	External Lock Washer 5/16	35.	781-0721	Lower Housing
15.	710-0502A	Hex Washer Screw 3/8-16 x 1.25	36.	712-3004A	Lock Nut 5/16-18
16.	710-0969	Screw #12-16 x 1.0	37.	731-1905	Nozzle Cover
17.	710-3195	Hex Cap Screw 5/16-18 x 4.5	38.	712-0158	Lock Nut 5/16-18
18.	710-3025	Hex Cap Screw 5/16-18 x .625	39.	751B281440	Shroud
19.	710-0604A	Hex Washer Screw 5/16-18 x .625	40.	710-1256	Screw #8-18 x 1.25
20.	781-0720	Upper Housing	41.	731-1613	Safety Switch Cover
21.	710-1054	Hex Screw 5/16-24 x 1.0			

**NOTE:** For **painted parts**, please refer to the list of color codes below. Please add the applicable color code, wherever needed, to the part number to order a replacement part. For instance, if a part, numbered 700-xxxx, is painted Cub Yellow, the part number to order would be 700-xxxx-0498.

Cub Yellow: 0498  
 Cub Beige: 0499  
 Powder Black: 0637

# Model 24A-030E100

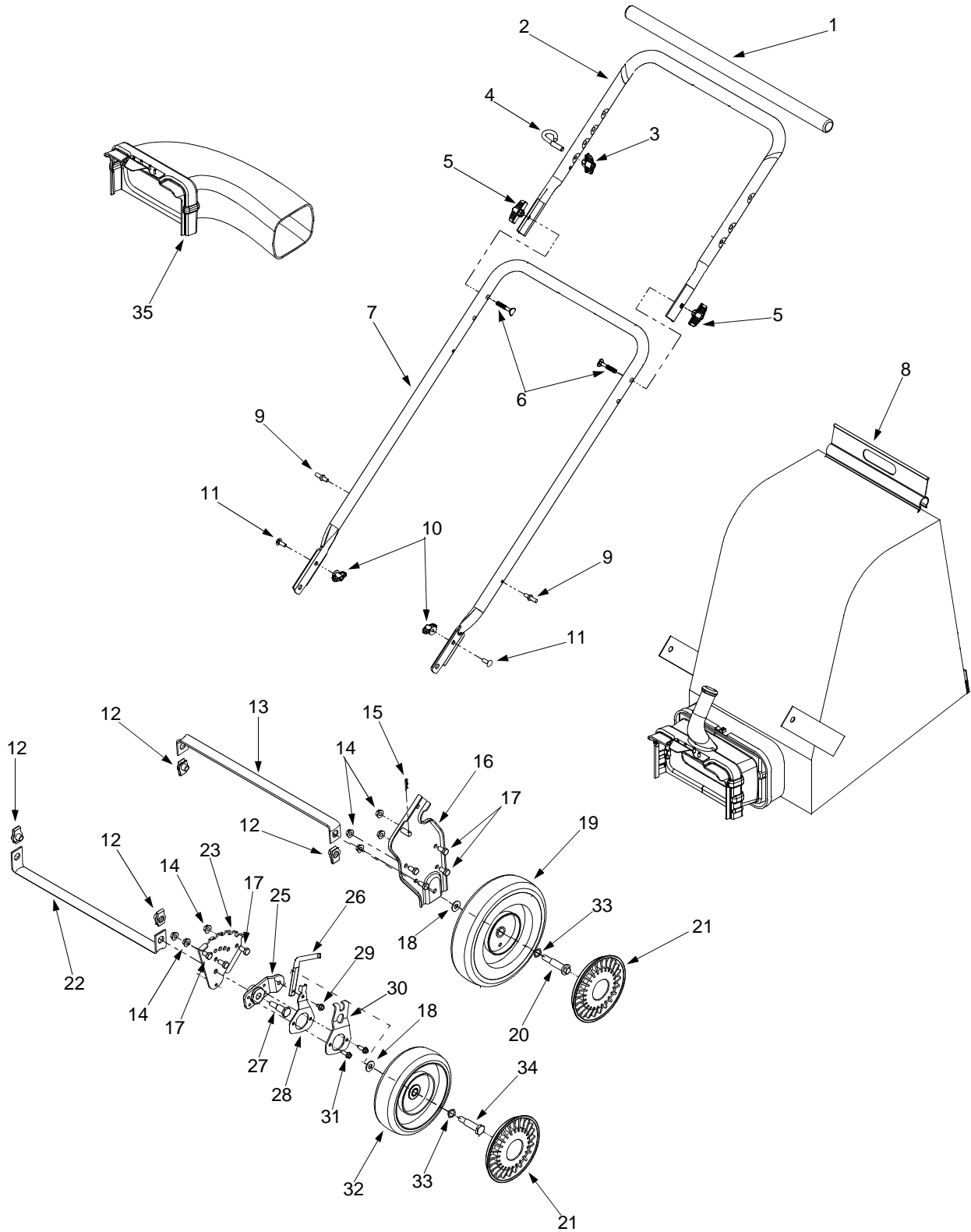



# Model 24A-030E100

Ref. No.	Part No.	Part Description	Ref. No.	Part No.	Part Description
1.	720-0295	Foam Grip	18.	736-0105	Bell Washer.401 ID x.870 OD
2.	749-0438C	Upper Handle	19.	734-1992	Wheel 9 x 2
3.	720-0279	Knob	20.	738-1015	Shoulder Screw 3/8-16
4.	710-1205	Eye Bolt	21.	731-0982A	Hubcap
5.	720-0276	Handle Knob 5/16-18	22.	781-0725	Front Wheel Support Brace
6.	710-1174	Carriage Bolt	23.	781-0765	Hgt Bracket Adjuster LH
7.	749-0907A	Lower Handle		781-0766	Height Brkt Adj RH (Not Shown)
8.	664-0090	Bag Assembly	25.	748-0417	Pivot Arm
9.	711-1293	Studs	26.	747-1100	Handle Height Adjuster
10.	712-0397	Wing Nut 1/4-20	27.	738-1017	Shoulder Screw 3/8-16
11.	710-0703	Carriage Screw 1/4-20 x .75	28.	732-0864	Height Adjuster Plate Spring
12.	726-0453	Lock U-Clip Nut 3/8-16	29.	710-0653	Hex Washer Screw 1/4-20 x .375
13.	781-0777	Rear Wheel Support Brace	30.	782-0578	Spring Lever Support Bracket
14.	712-3004A	Flange Lock Nut 5/16-18	31.	710-0642	Hex Washer Screw 1/4-20 x .75
15.	714-0104	Cotter Pin	32.	734-1978	Wheel 8 x 2
16.	681-0155	Handle Bracket Ass'y LH	33.	736-0232	Wave Washer .531 ID x .781 OD
	681-0156	Hndle Brkt Ass'y RH (Not Shown)	34.	738-0213	Shoulder Screw
17.	710-3025	Hex Cap Screw 5/16-18 x .625	35.	631-0090	Blower Chute Assembly





# MANUFACTURER'S LIMITED WARRANTY FOR:



## **TWO-YEAR RESIDENTIAL ONE-YEAR COMMERCIAL**

Proper maintenance of your Cub Cadet equipment is the owner's responsibility. Follow the instructions in your operator's manual for correct lubricants and maintenance schedule. Your Cub Cadet dealer carries a complete line of quality lubricants and filters for your equipment's engine, transmission, chassis and attachments.

### **Riding mowers, lawn tractors, garden tractors, Cub Cadet attachments and home maintenance products**

This limited warranty for residential users, covers any defect in materials or workmanship in your Cub Cadet equipment for two years from the date of purchase for the first user purchaser. We will replace or repair any part or parts without charge through your authorized Cub Cadet dealer.

Batteries have a one-year prorated limited warranty with 100% replacement during the first three months.

V-belts for either the traction drive or any attachments are covered for one year only.

Cub Cadet equipment used commercially is warranted for one year only.

(Commercial use is defined as either having hired operators or used for income producing purposes.)

### **Items not covered**

The warranty does not cover routine maintenance items such as lubricants, filters (oil, fuel, air and hydraulic), cleaning, tune-ups, brake and/or clutch inspection, adjustments made as part of normal maintenance, blade sharpening, set-up, abuse, accidents and normal wear. It does not cover incidental costs such as transporting your equipment to and from the dealer, telephone charges or renting a product temporarily to replace a warranted product.

There is no other express warranty.

### **How to obtain service**

Contact your authorized Cub Cadet servicing dealer who sold you your Cub Cadet equipment. If this dealer is not available, see the Consumer Yellow Pages under "lawn mowers" for the name of a dealer near you.

If you need further assistance in finding an authorized Cub Cadet servicing dealer, contact:

**Cub Cadet Corporation  
Post Office Box 368023  
Cleveland, Ohio 44136**

### **How does state law apply?**

This limited warranty gives you specific legal rights, and you may also have other rights which vary from state to state.

## Free Manuals Download Website

<http://myh66.com>

<http://usermanuals.us>

<http://www.somanuals.com>

<http://www.4manuals.cc>

<http://www.manual-lib.com>

<http://www.404manual.com>

<http://www.luxmanual.com>

<http://aubethermostatmanual.com>

Golf course search by state

<http://golfingnear.com>

Email search by domain

<http://emailbydomain.com>

Auto manuals search

<http://auto.somanuals.com>

TV manuals search

<http://tv.somanuals.com>