

Cub Cadet

Installation Instructions

759-04080 CRUISE CONTROL KIT

For Series 6000 Tractor Models

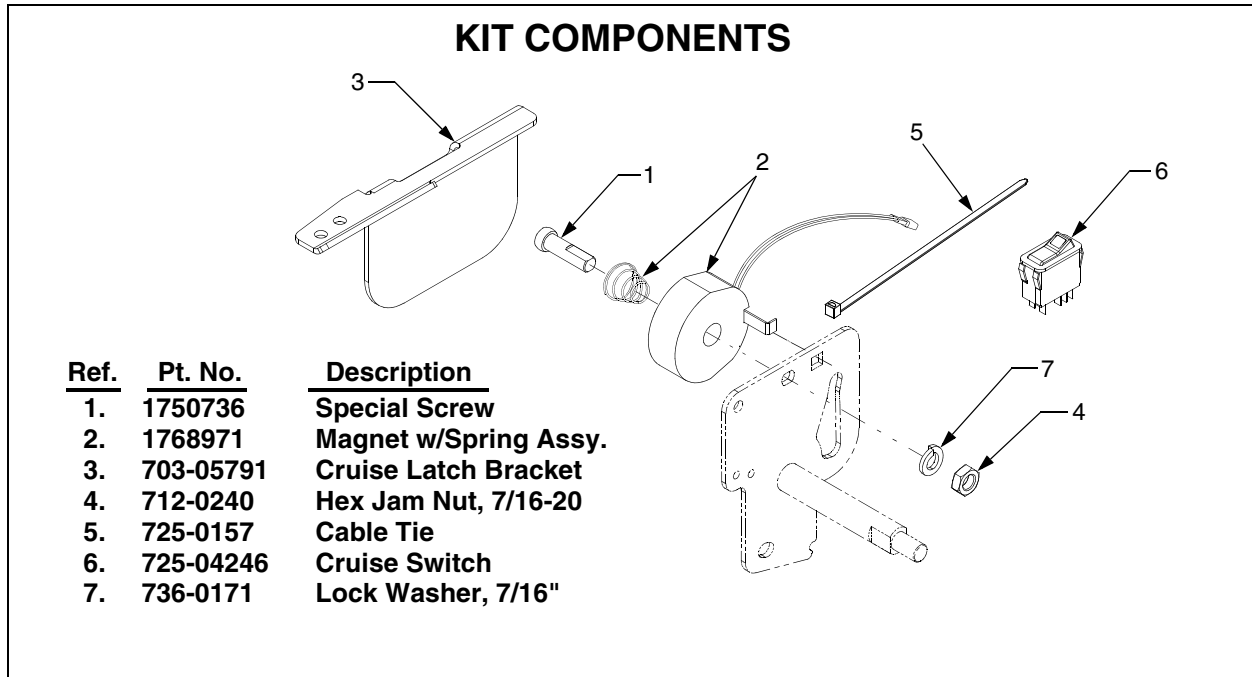

Introduction

The cruise control kit is designed to allow the tractor operator to maintain a desired "foot free" **forward speed** in areas where constant speed changes are not required. *The cruise control feature can only be operated in the forward direction.*

Installing the Cruise Control Kit

NOTE: Some installation procedures are more easily performed from beneath the tractor. If equipped, the mower deck may be removed from the tractor to improve access.

Wire leads w/connectors needed to power the cruise control magnet are provided in the tractor wire harness.

To install the cruise control kit, proceed as follows:

- Remove the plug from the right side of the dash panel by sliding a thin flat edged tool beneath the plug and prying upward. See Figure 1.

NOTE: The wire harness connector for the cruise switch may be connected to the dash panel plug. If so, carefully pull the wire harness connector up through the dash panel while removing the plug. If the wire harness leads are not connected to the plug, it will be necessary to remove the dash panel insert.

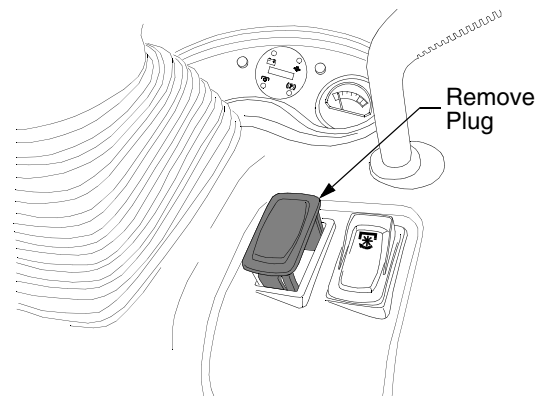

Figure 1

CUB CADET LLC P.O. BOX 361131 CLEVELAND, OHIO 44136-0019

PRINTED IN U.S.A.

FORM NO. 769-01718 (3/05)

- Remove the dash panel insert by removing the two screws and lifting the insert out (See Figure 2).
- Locate the unused dash harness connector (with green(2), green w/white, red w/black, yellow w/ black, and violet wires) inside the dash panel. Lift the connector up through the hole in the dash panel from which the plug was just removed.

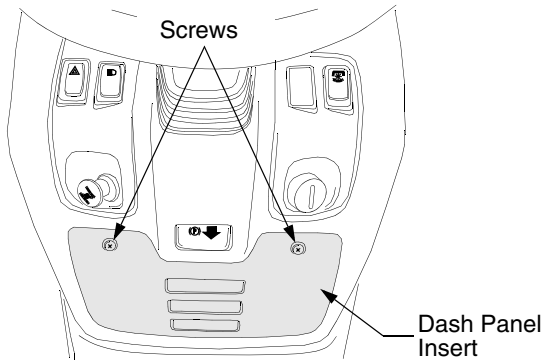

Figure 2

- Align the cruise switch (Ref.6) and the dash harness connector so that the locator tabs on each side of the connector will slide up on the flat area of the switch, then plug the switch into the connector. See Figure 3.

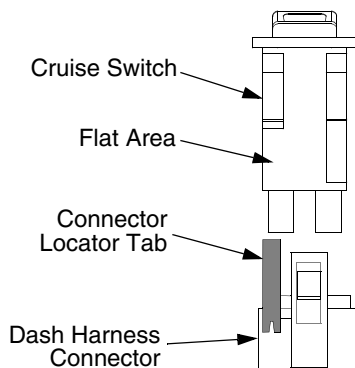

Figure 3

- With the light area of the switch positioned toward the top, push the cruise switch fully into the hole in the dash panel.
- Reinstall the dash panel insert and secure with the two screws.
- Remove the four hex tapp screws and two truss head screws securing the fender cover; then remove the cover from the tractor. Refer to Figure 4.

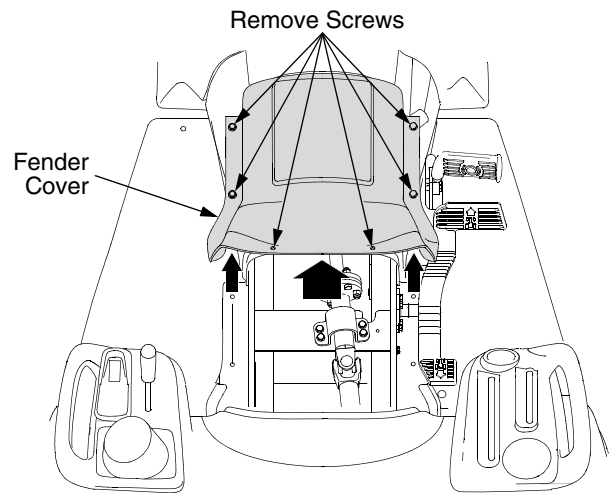

Figure 4

- From beneath the right running board, locate the hex lock nut on the end of the pedal shaft. Using a 3/4" socket and long socket extension, loosen the lock nut so that it is unthreaded beyond the end of the pedal shaft threads. See Figure 5.

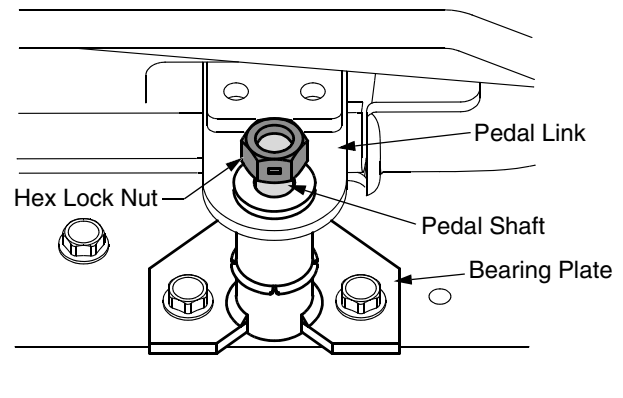

Figure 5

IMPORTANT: Use care to avoid damaging the hydraulic outlet tubes when completing the following step.

- Using a mallet and a 3/4" or larger bar placed against the hex lock nut, carefully drive the pedal shaft toward the left side of the tractor.

NOTE: The control linkage of the tractor will limit the distance the pedal shaft can be moved. Do not force the pedal shaft; move the shaft only as far as necessary to install the lock washer and nut on the frame side of the pedal shaft plate. Refer to Figure 6.

- Slide the compression spring (Ref. 2), large end first, onto the special screw. Refer to Figure 6.
- Insert the double 'D' end of the special screw (Ref. 1) into the double 'D' hole of the pedal shaft plate. Refer to Figure 6.

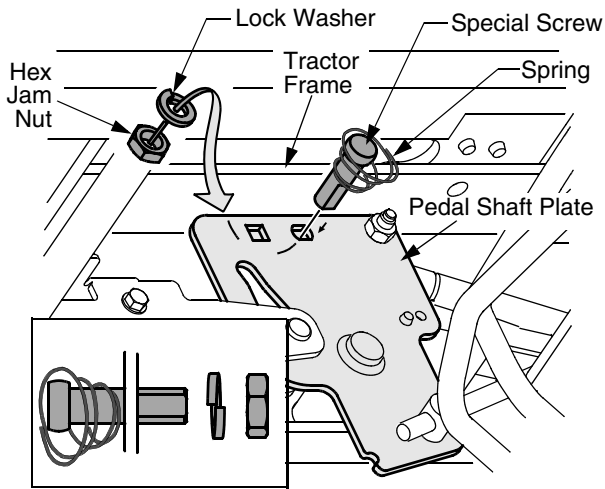

Figure 6

- Slide the lock washer (Ref.7) onto the special screw, then thread the hex jam nut (Ref.4) onto the screw. Refer to Figure 6.

NOTE: Because of limited space between the pedal shaft plate and frame, it may be easier to install the hex jam nut from the underside of the tractor.

- Fully tighten the hex jam nut onto the special screw. Then from beneath the right running board carefully retighten the hex lock nut to reposition the pedal shaft. Refer to Figure 5.
- Hook the bent tab of the magnet (Ref. 2) into the square hole of the pedal shaft plate and pivot the magnet onto the special screw (See Figure 7). Push the magnet onto the screw so that the bent tab is behind the plate and retains the magnet on the screw.

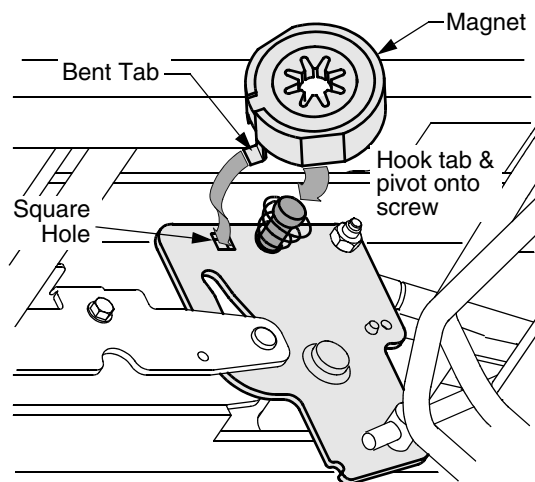

Figure 7

- Remove the two hex tapp screws securing the right side of the tractor drive shaft shield to the frame. Refer to Figure 8.

- Insert the cruise latch bracket (Ref. 3) down through the opening in the fender/running board so that its large plate area is against the left side of the magnet. See Figure 8.

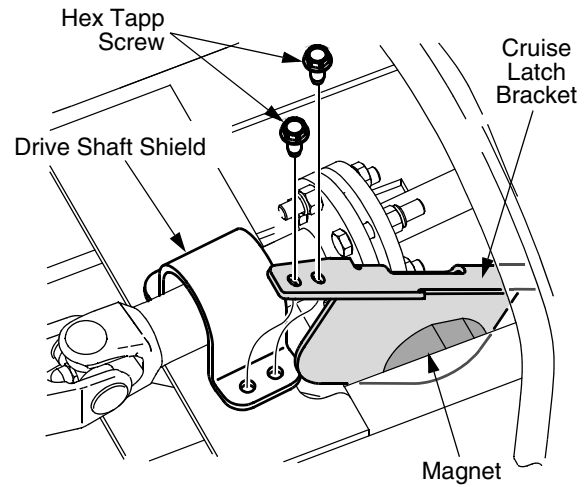

Figure 8

- Pivot the rear of the cruise latch bracket downward so that the bracket mounting holes align with the holes of the drive shaft shield. Refer to Figure 8.
- While holding the cruise latch bracket tightly against the magnet, secure the bracket with the two hex tapp screws removed earlier. Refer to Figure 8.
- Locate the unused two wire connector of the main wire harness along the right side of the frame (See Figure 9). Plug the two wires from the magnet into the wire harness connector.

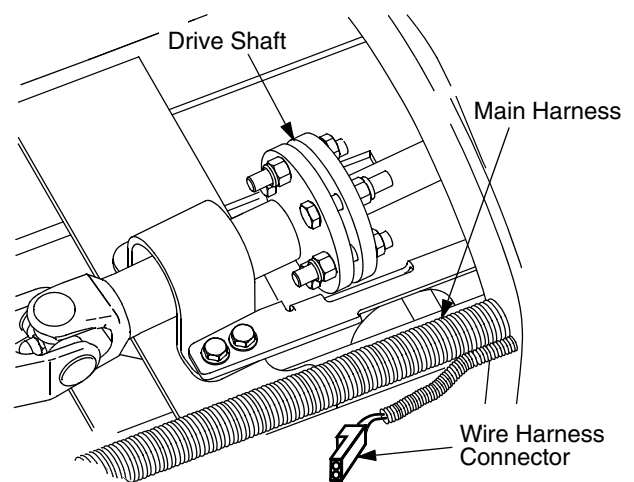

Figure 9

- Use the cable tie (Ref.5) to secure the wire harness lead and magnet wires to the main harness, away from the drive shaft. Refer to Figure 9.

Setting The Cruise Control



WARNING: Always use extreme caution when operating the tractor with the cruise control engaged. Use good judgement and maintain a safe speed for the conditions of operation.

NOTE: The cruise control feature can only be operated in the forward direction.

- Slowly depress the forward control pedal until the desired speed is achieved.
- While holding the forward control pedal, depress the top of cruise control switch to energize the magnet and engage the cruise control. **NOTE:** The light of the switch will illuminate to indicate the switch has been depressed to the "ON" position.
- If the cruise control has engaged, the forward control pedal will lock in the desired position, and the tractor will maintain the same forward speed when you remove your foot from the pedal.
- If you wish to increase the speed while the cruise control is engaged, simply depress the forward pedal further. It is not necessary to disengage and re-engage the cruise control.

Disengaging the Cruise Control

NOTE: Regardless of the method used, the indicator light in the cruise switch will turn off when the cruise control is disengaged. Simply depress the top of the switch to re-engage the cruise control.

Disengage the cruise control using one of the following methods:

- Depress the brake pedal to disengage the cruise control and stop the tractor.
- Depress the bottom of the cruise control switch to disengage the cruise control.

NOTE: Although not recommended, depressing the forward/reverse pedal to the reverse position will also disengage the cruise control.

To change to the reverse direction when operating with cruise control, use one of the recommended methods to disengage the cruise control, then depress the reverse control pedal.

Free Manuals Download Website

<http://myh66.com>

<http://usermanuals.us>

<http://www.somanuals.com>

<http://www.4manuals.cc>

<http://www.manual-lib.com>

<http://www.404manual.com>

<http://www.luxmanual.com>

<http://aubethermostatmanual.com>

Golf course search by state

<http://golfingnear.com>

Email search by domain

<http://emailbydomain.com>

Auto manuals search

<http://auto.somanuals.com>

TV manuals search

<http://tv.somanuals.com>