

Cub Cadet

Operator's Manual

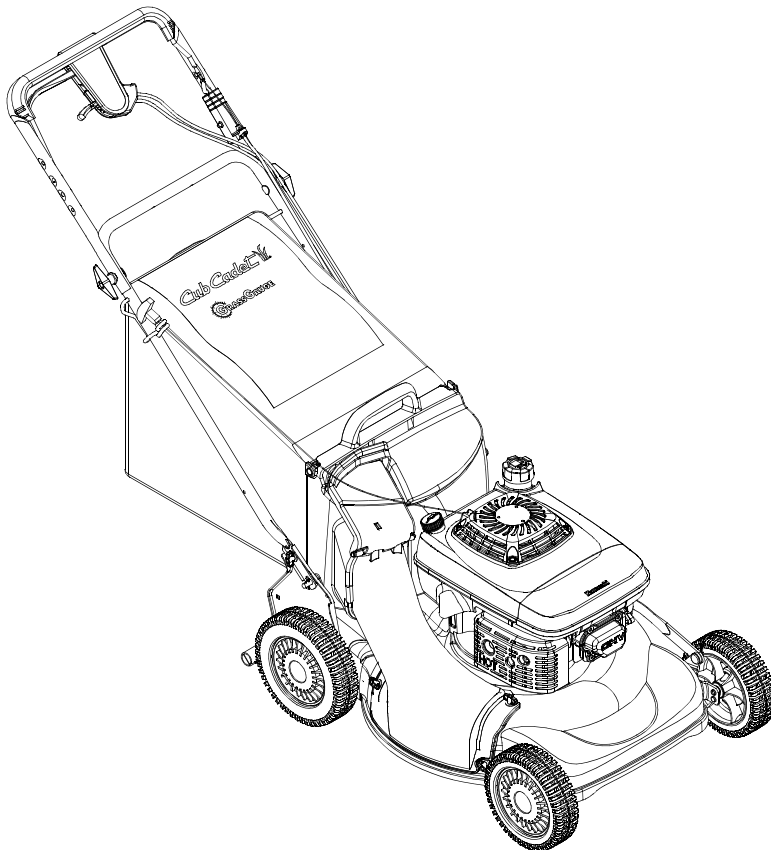

21" Self-Propelled Mower

Models 977A & E977C

IMPORTANT: Read safety rules and instructions carefully

Warning: This unit is equipped with an internal combustion engine and should not be used on or near any unimproved forest-covered, brush-covered or grass-covered land unless the engine's exhaust system is equipped with a spark arrester meeting applicable local or state laws (if any). If a spark arrester is used, it should be maintained in effective working order by the operator. In the State of California the above is required by law (Section 4442 of the California Public Resources Code). Other states may have similar laws. Federal laws apply on federal lands. A spark arrester for the muffler is available through your Cub Cadet dealer or contact the service department, P.O. Box 361131 Cleveland, Ohio 44136-0019.

Cub Cadet LLC., P.O. Box 361131, Cleveland, Ohio 44136-0019

PRINTED IN U.S.A.

Form No.769-00483
(11/2002)

TABLE OF CONTENTS

Content	Page
Important Safe Operation Practices.....	3
Slope Gauge.....	6
Assembling Your Lawn Mower	7
Know Your Lawn Mower	9
Operating Your Lawn Mower	10
Making Adjustments	11
Maintaining Your Lawn Mower	13
Troubleshooting.....	17
Parts List.....	18
Engine Manual.....	23

FINDING MODEL NUMBER

This Operator's Manual is an important part of your new lawn mower. It will help you assemble, prepare and maintain the unit for best performance. Please read and understand what it says.



Before you start assembling your new equipment, please locate the model plate on the equipment and copy the information from it in the space provided below. The information on the model plate is very important if you need help from our Customer Support Department or an authorized dealer.

- You can locate the model number by standing at the operating position and looking down at the rear of the mower deck. A sample model plate is explained below. For future reference, please copy the model number and the serial number of the equipment in the space below.

_____	_____
(Model Number)	(Serial Number)

CUB CADET LLC
P. O. BOX 361131
CLEVELAND, OH 44136
DEALER LOCATOR PHONE NUMBER: 877-282-8684

Copy the model number here: _____

Copy the serial number here: _____

ENGINE INFORMATION

The engine manufacturer is responsible for all engine-related issues with regards to performance, power-rating, specifications, warranty and service. Please refer to the engine manufacturer's Owner's/Operator's Manual packed separately with your unit for more information.

CALLING CUSTOMER SUPPORT

If you have difficulty assembling this product or have any questions regarding the controls, operation or maintenance of this unit, please call the Customer Support Department.



Call **1-877-282-8684** to reach a Customer Support representative. Please have your unit's model number and serial number ready when you call. See previous section to locate this information. You will be asked to enter the serial number in order to process your call.

For more details about your unit, visit our website at www.cubcadet.com

SECTION 1: IMPORTANT SAFE OPERATION PRACTICES



WARNING: This symbol points out important safety instructions which, if not followed, could endanger the personal safety and/or property of yourself and others. Read and follow all instructions in this manual before attempting to operate this machine. Failure to comply with these instructions may result in personal injury. When you see this symbol—HEED ITS WARNING.

WARNING: Engine exhaust, some of its constituents, and certain vehicle components contain or emit chemicals known to State of California to cause cancer and birth defects or other reproductive harm.

WARNING: This machine was built to be operated according to the rules for safe operation in this manual. As with any type of power equipment, carelessness or error on the part of the operator can result in serious injury. This machine is capable of amputating hands and feet and throwing objects. Failure to observe the following safety instructions could result in serious injury or death.

General Operation

1. Read this operator's manual carefully in its entirety before attempting to assemble this machine. Read, understand, and follow all instructions on the machine and in the manual(s) before operation. Be completely familiar with the controls and the proper use of this machine before operating it. Keep this manual in a safe place for future and regular reference and for ordering replacement parts.
2. This machine is a precision piece of power equipment, not a plaything. Therefore, exercise extreme caution at all times. Your unit has been designed to perform one job: to mow grass. Do not use it for any other purpose.
3. Never allow children under 14 years old to operate this machine. Children 14 years old and over should read and understand the operation instructions and safety rules in this manual and should be trained and supervised by a parent. Only responsible individuals who are familiar with these safe operation rules should use this machine.
4. Thoroughly inspect the area where equipment is to be used. Remove all stones, sticks, wire, bones, toys and other foreign objects which could be tripped over or picked up and thrown by the blade. Thrown objects can cause serious personal injury. Plan your mowing pattern to avoid discharge of material toward roads, sidewalks, bystanders and the like. Also, avoid discharging material against a wall or obstruction which may cause discharged material to ricochet back toward the operator.
5. To help avoid blade contact or a thrown object injury, stay in the operator zone behind the handles and keep bystanders, helpers, children and pets at least 75 feet from the machine while it is in operation. Stop machine if anyone enters the area.
6. Always wear safety glasses to protect your eyes during equipment operation and while performing an adjustment or repair. Thrown objects which ricochet can cause serious injury to the eyes.
7. Wear sturdy, rough-soled work shoes and close-fitting slacks and shirts. Shirts and pants that cover the arms and legs and steel-toed shoes are recommended. Never operate this machine in bare feet, sandals, slippery or light weight (e.g. canvas) shoes.
8. Do not put hands or feet near rotating parts or under the cutting deck. Contact with the blade can amputate hands and feet.
9. A missing or damaged discharge cover can cause blade contact or thrown object injuries.
10. Many injuries occur as a result of the mower being pulled over the foot during a fall caused by slipping or tripping. Do not hold on to the mower if you are falling; release the handle immediately.
11. Never pull the mower back toward you while you are walking. If you must back the mower away from a wall or obstruction first look down and behind to avoid tripping and then follow these steps:
 - a. Step back from the mower to fully extend your arms.
 - b. Be sure you are well balanced with sure footing.
 - c. Pull the mower back slowly, no more than half way toward you.
 - d. Repeat these steps as needed.
5. Do not operate the mower while under the influence of alcohol or drugs.
6. Do not engage the self-propelled mechanism on units so equipped while starting engine.
7. The blade control handle is a safety device. Never attempt to bypass its operation. Doing so makes the safety device inoperative and may result in personal injury through contact with the rotating blade. The blade control handle must operate easily in both directions and automatically return to the disengaged position when released.
8. Never operate the mower in wet grass. Always be sure of your footing. A slip and fall can cause serious personal injury. If you feel you are losing your footing, release the blade control handle

immediately and the blade will stop rotating within three seconds.

9. Mow in daylight or good artificial light; walk, not run.
10. Stop the blade when crossing gravel drives, walkways or roads.
11. If the equipment should start to vibrate abnormally, stop the engine and check immediately for the cause. Vibration is generally a warning of trouble.
12. Shut the engine off and wait until the blade comes to a complete stop before removing the grass catcher or unclogging the chute. The cutting blade continues to rotate for a few seconds after the engine is shut off. Never place any part of the body in the blade area until you are sure the blade has stopped rotating.
13. Never operate mower without proper trail shield, discharge cover, grass catcher, blade control handle or other safety protective devices in place and working. Never operate mower with damaged safety devices. Failure to do so can result in personal injury.
14. Muffler and engine become hot and can cause a burn. Do not touch.
15. Only use parts and accessories made by the original equipment manufacturer (O.E.M). Failure to do so can result in personal injury.
16. If situations occur which are not covered in this manual, use care and good judgment. Contact your dealer for assistance. Call 1-877-282-8684 for the name of your nearest dealer.

Slope Operation

Slopes are a major factor related to slip and fall accidents which can result in severe injury. Operation on slopes requires extra caution. If you feel uneasy on a slope, do not mow it. Before operating this unit on a slope or hilly area, use the slope gauge on page 6 to measure slopes. If the slope is greater than 15 degrees, do not mow it.

Do:

1. Mow across the face of slopes; never up and down. Exercise caution when changing direction.
2. Watch for holes, ruts, rocks, hidden objects, or bumps which can cause you to slip or trip. Tall grass can hide obstacles.
3. Always be sure of your footing. A slip and fall can cause serious personal injury. If you feel you are losing your balance, release the blade control handle immediately, and the blade will stop rotating within 3 seconds.

Do Not:

1. Do not mow near drop-offs, ditches or embankments, you could lose your footing or balance.
2. Do not mow slopes greater than 15 degrees as shown on the slope gauge.

3. Do not mow on wet grass. Unstable footing could cause slipping.

Children

Tragic accidents can occur if the operator is not alert to the presence of children. Children are often attracted to the mower and the mowing activity. They do not understand the dangers. Never assume that children will remain where you last saw them.

1. Keep children out of the mowing area and under the watchful care of a responsible adult other than the operator.
2. Be alert and turn mower off if a child enters the area.
3. Before and while moving backwards, look behind and down for small children.
4. Use extreme care when approaching blind corners, doorways, shrubs, trees, or other objects that may obscure your vision of a child who may run into the mower.
5. Keep children away from hot or running engines. They can suffer burns from a hot muffler.
6. Never allow children under 14 years old to operate a power mower. Children 14 years old and over should read and understand the operation instructions and safety rules in this manual and should be trained and supervised by a parent.

Service

Safe Handling of Gasoline:

1. To avoid personal injury or property damage use extreme care in handling gasoline. Gasoline is extremely flammable and the vapors are explosive. Serious personal injury can occur when gasoline is spilled on yourself or your clothes which can ignite.
2. Wash your skin and change clothes immediately.
3. Use only an approved gasoline container.
4. Never fill containers inside a vehicle or on a truck or trailer bed with a plastic liner. Always place containers on the ground away from your vehicle before filling.
5. If possible, remove gas-powered equipment from the truck or trailer and refuel it on the ground. If this is not possible, then refuel such equipment on a trailer with a portable container, rather than from a gasoline dispenser nozzle.
6. Keep the nozzle in contact with the rim of the fuel tank or container opening at all times until fueling is complete. Do not use a nozzle lock-open device.
7. Extinguish all cigarettes, cigars, pipes and other sources of ignition.
8. Never fuel machine indoors because flammable vapors will accumulate in the area.
9. Never remove gas cap or add fuel while the engine is hot or running. Allow engine to cool at least two minutes before refueling.

10. Never over fill fuel tank. Fill tank to no more than ½ inch below bottom of filler neck to provide space for fuel expansion.
11. Replace gasoline cap and tighten securely.
12. If gasoline is spilled, wipe it off the engine and equipment. Move unit to another area. Wait 5 minutes before starting the engine.
13. Never store the machine or fuel container inside where there is an open flame, spark or pilot light as on a water heater, space heater, furnace, clothes dryer or other gas appliances.
14. To reduce fire hazard, keep mower free of grass, leaves, or other debris build-up. Clean up oil or fuel spillage and remove any fuel soaked debris.
15. Allow mower to cool 5 minutes before storing.

General Service:

1. Never run an engine indoors or in a poorly ventilated area. Engine exhaust contains carbon monoxide, an odorless and deadly gas.
2. Before cleaning, repairing, or inspecting, make certain the blade and all moving parts have stopped. Disconnect the spark plug wire and ground against the engine to prevent unintended starting.
3. Check the blade and engine mounting bolts at frequent intervals for proper tightness. Also, visually inspect blade for damage (e.g., bent, cracked, worn) Replace blade with the original equipment manufacturer's (O.E.M.) blade only, listed in this manual. "Use of parts which do not meet the original equipment specifications may lead to improper performance and compromise safety!"

4. Mower blades are sharp and can cut. Wrap the blade or wear gloves, and use extra caution when servicing them.
5. Keep all nuts, bolts, and screws tight to be sure the equipment is in safe working condition.
6. Never tamper with safety devices. Check their proper operation regularly.
7. After striking a foreign object, stop the engine, disconnect the spark plug wire and ground against the engine. Thoroughly inspect the mower for any damage. Repair the damage before starting and operating the mower.
8. Never attempt to make a wheel or cutting height adjustment while the engine is running.
9. Grass catcher components, discharge cover, and trail shield are subject to wear and damage which could expose moving parts or allow objects to be thrown. For safety protection, frequently check components and replace immediately with original equipment manufacturer's (O.E.M.) parts only, listed here. Use of parts which do not meet the original equipment specifications may lead to improper performance and compromise safety.
10. Do not change the engine governor setting or overspeed the engine. The governor controls the maximum safe operating speed of the engine.
11. Maintain or replace safety and instruction labels, as necessary.
12. Observe proper disposal laws and regulations. Improper disposal of fluids and materials can harm the environment.

Your Responsibility

- Restrict the use of this power machine to persons who read, understand and follow the warnings and instructions in this manual and on the machine.



SECTION 2: SLOPE GAUGE

Use this page as a guide to determine slopes where you may not operate safely. **Do not operate** your lawn mower on such slopes.

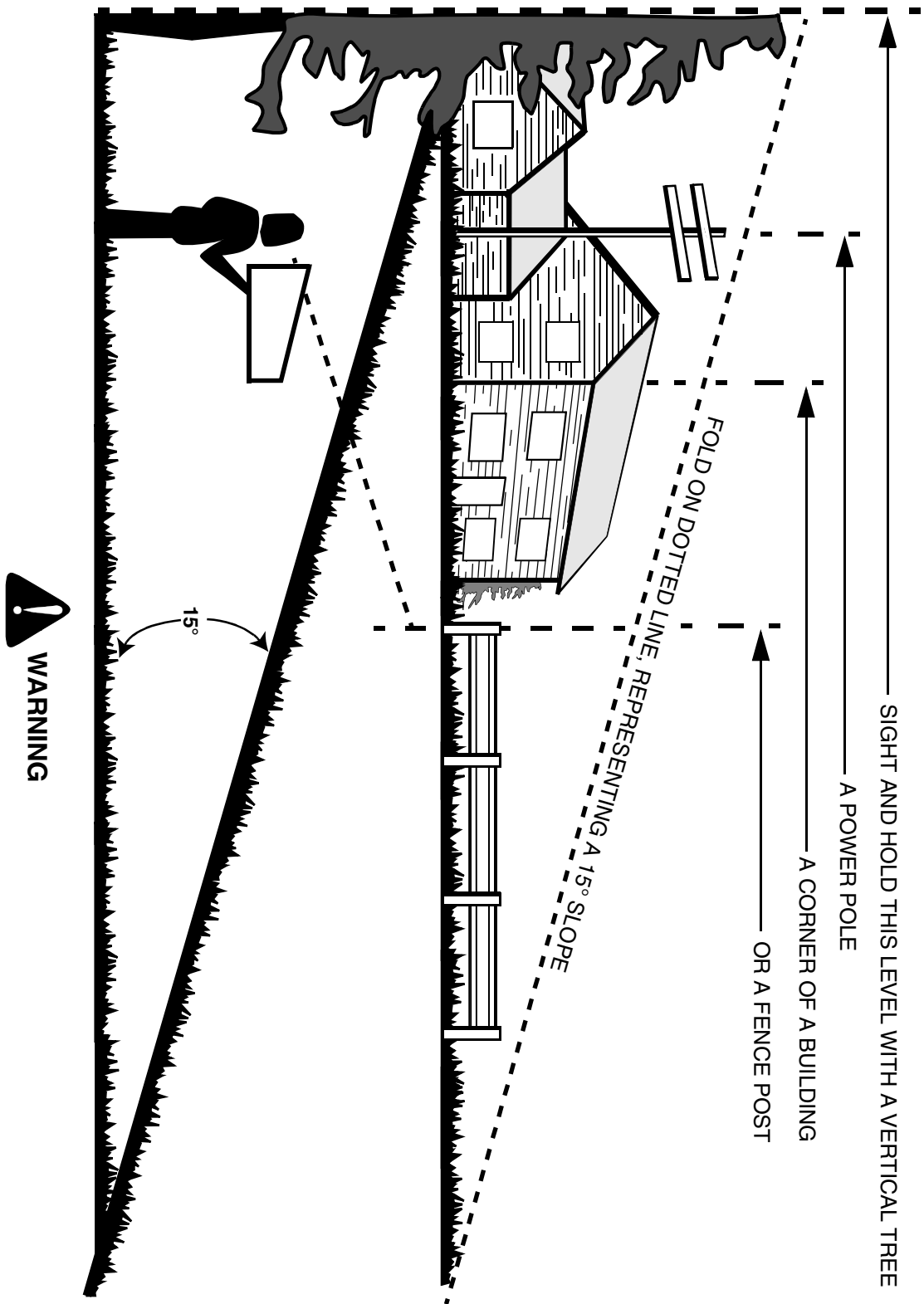

WARNING

Do not mow on inclines with a slope in excess of 15 degrees (a rise of approximately 2-1/2 feet every 10 feet). A riding mower could overturn and cause serious injury. If operating a walk-behind mower on such a slope, it is extremely difficult to maintain your footing and you could slip, resulting in serious injury.

Operate RIDING mowers up and down slopes, never across the face of slopes.

Operate WALK-BEHIND mowers across the face of slopes, never up and down slopes.

SECTION 3: ASSEMBLING YOUR LAWN MOWER

Removing Unit From Carton

- Remove staples, break glue on top flaps, or cut tape at carton end and peel along top flap to open carton.
- Remove loose parts, if included with unit (i.e., grass bag etc.), and save it appropriately.
- Cut along corners, lay the carton down flat, and remove all packing material.
- Roll or slide unit out of carton and check carton thoroughly for loose parts.

Loose Parts in Carton

1. Grass Bag
2. Grass Bag Adapter
3. Side Discharge Chute
4. Hardware Pack

Hardware Pack

Please identify each piece of the hardware pack as shown in Figure 1.

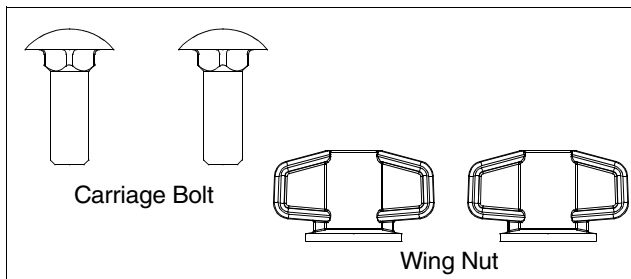

Figure 1

Before Assembly

- Before setting up your lawn mower, disconnect the spark plug wire from the spark plug and ground against the engine. See Figure 2.

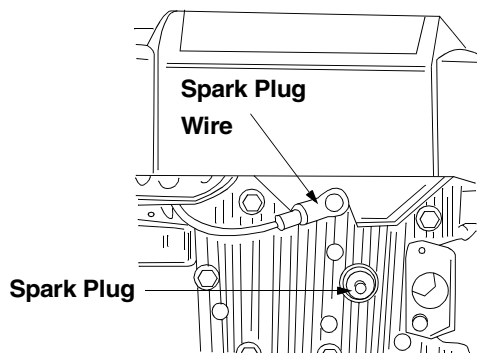

Figure 2

NOTE: Reference to right or left side of the mower is observed from the operating position.

Setting Up Your Lawn Mower

Assembling Handle

- Lift up and pull back on the upper handle to raise the handle into the operating position. See Figure 3. Make certain the lower handle is seated securely into the handle bracket assemblies.

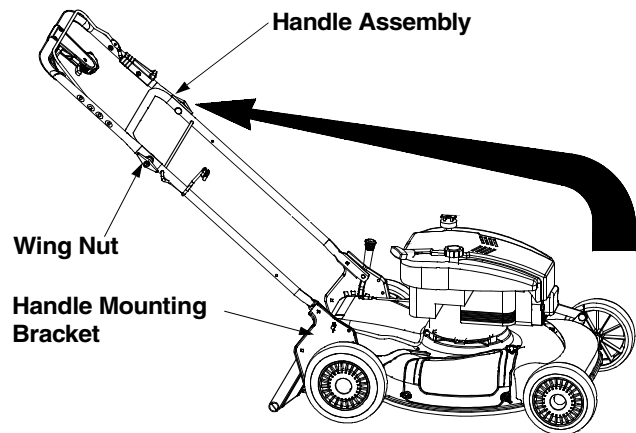

Figure 3

- Tighten wing nuts on each side of the handle making sure that the carriage bolts are seated properly into the handle. See Figure 3.
- Remove hairpin clip from the outer hole of the weld pin on each handle brackets. Using a pair of pliers, squeeze one leg of the lower handle against the handle bracket. Insert the hairpin clip into the inner hole on the weld pin. Repeat on the other side. See Figure 4.
- After moving the hairpin clip, insert the carriage bolt, from the hardware pack, in the upper hole on the handle mounting bracket and secure with plastic wing nut, also from the hardware pack. See Figure 4. Repeat on the other side.

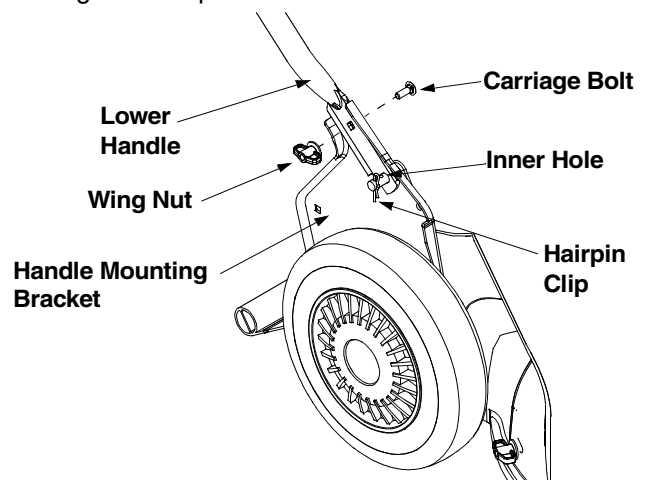

Figure 4

- Fasten the cable to the lower handle with the two cable ties found on the lower handle. Pull the cable ties tight and trim off the excess. See Figure 5.

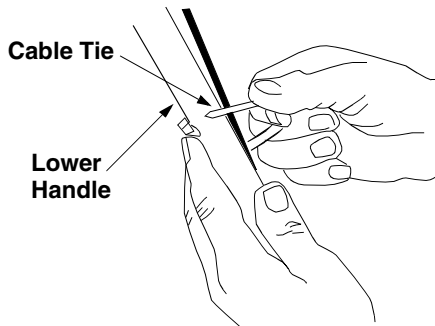

Figure 5

Attaching Starter Rope

NOTE: Make certain the drive cable is routed around the outside and above the lower handle so it does not interfere with attaching the grass bag.

- The rope guide, which is connected to the support rod, is located on the right side of the lower handle. See Figure 6.
- With the spark plug wire disconnected and grounded, hold the blade control handle against the upper handle, and pull the starter rope out of the engine. Release the blade control handle. Slip the starter rope into the rope guide.

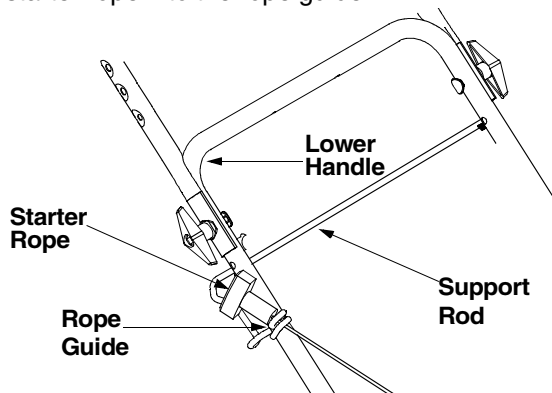

Figure 6

Attaching The Grass Bag

The mower was shipped with the mulching baffle installed on the unit. You can keep this baffle on as long as you want to mulch the grass clippings. For bagging purposes, you will have to attach the grass bag and its adapter in place of the mulching baffle.

- Remove three wing nuts holding the mulching baffle or side discharge chute in place and remove the accessory from the unit.
- Replace with grass bag adapter, while making sure the front lip of adapter goes under the edge of the deck. Secure with wing nuts previously removed. See Figure 7.

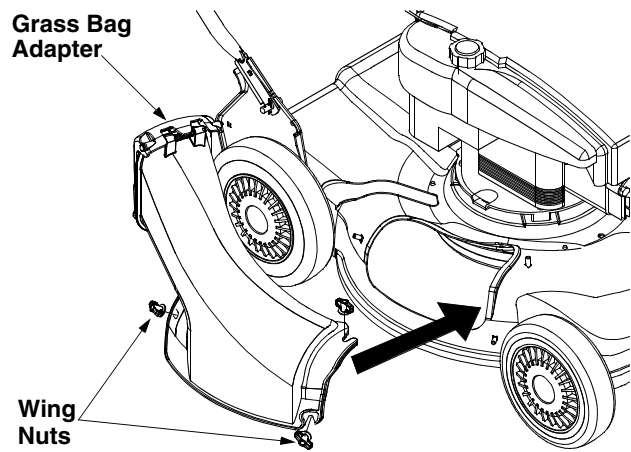

Figure 7

- Lift chute door on the grass bag adapter and slide grass bag onto the adapter. See Figure 8.

NOTE: The chute door has been designed to move the starter rope out of the way of the bag when the chute door is opened.

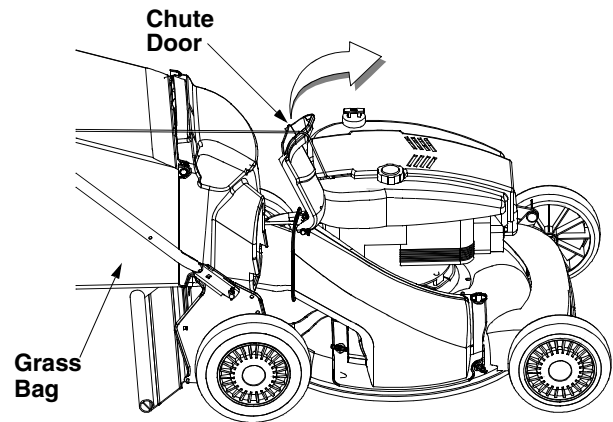

Figure 8

Attaching Side Discharge Chute

- Remove mulching baffle or grass bag adapter from unit by disconnecting wing nuts.
- Attach side discharge chute to unit and secure with the three wing nuts. See Figure 9.

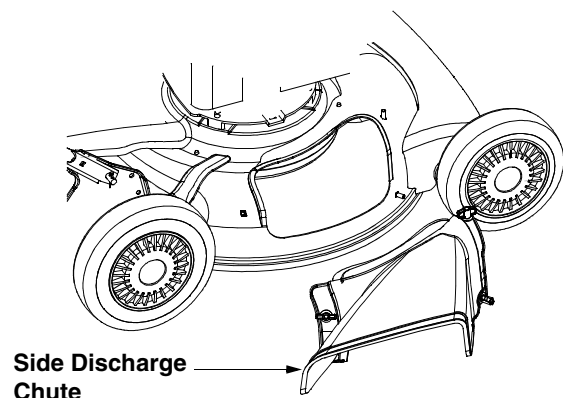

Figure 9

SECTION 4: KNOW YOUR LAWN MOWER

Read this operator's manual and safety rules before operating your lawn mower. Compare the illustration in Figure 10 with your lawn mower to familiarize yourself with the location of various controls and adjustments. Save this manual for future reference.



WARNING: The operation of any lawn mower can result in foreign objects being thrown into the eyes, which can damage your eyes severely. Always wear safety glasses while operating the mower, or while performing any adjustments or repairs on it.

Blade Control Handle

The blade control handle is located on the upper handle of the mower. The blade control handle must be depressed in order to operate the unit. Release blade control handle to stop engine and blade.



WARNING: This blade control mechanism is a safety device. Never attempt to bypass its operations.

Cutting Height Adjustment Levers

The cutting height adjustment lever is located above the left rear wheel. To adjust the cutting height, refer to the Adjustment Section in this manual.

Recoil Starter

The recoil starter is attached to the right upper handle. Stand behind the unit and pull the recoil starter rope to start the unit.

Drive Clutch Control

The drive clutch control is located on the upper handle. Squeeze the drive control to engage the drive system. Release the clutch control to disengage the drive system. Release the clutch control to slow down when approaching an obstacle, making a turn, or stopping.

Shift Lever

The shift lever is located on the drive clutch control housing on the upper handle. This lever is used to select the forward speed of the mower. When changing speed selection, release the drive clutch control.

NOTE: Move the shift lever only when the engine is running. Changing the shift lever setting with the engine off can damage the mower.

Grass Bag

The grass bag is equipped with a bag-fill indicator called a Grass Gauge, to add convenience to your work. While the mower is running, air will flow through the bag and into the "sail." If the grass catcher is **empty**, air flows through easily pushing the sail up. If the grass catcher is **full**, air does not flow through it allowing the sail to fall. So the position of the sail acts as a bag-fill indicator signifying when to empty the grass bag.

Mulching Plug

The mulching plug is used only for mulching purposes. Instead of collecting grass clippings in a grass catcher, this mower has the option of recirculating the clippings back to the lawn.

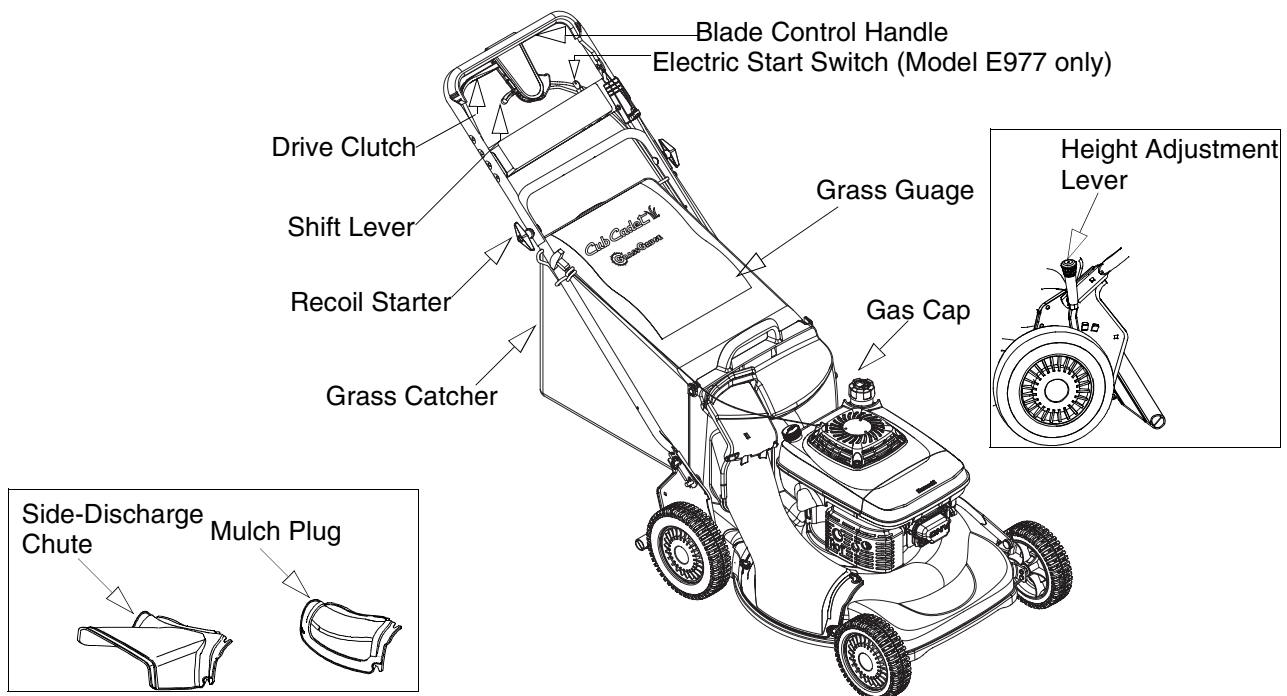

Figure 10

SECTION 5: OPERATING YOUR LAWN MOWER



WARNING: Read, understand, and follow all instructions and warnings on the machine and in this manual before operating.

NOTE: For shipping purposes your mower is set with the wheels in a low cutting height position. For best results, raise the cutting position until it is determined which height is best for your lawn. See the Adjustment Section for details.

Gas & Oil Fill-Up

- Check oil level and add oil if necessary. Follow relevant instructions in the engine manual for this.
- Service the engine with gasoline as instructed in the engine manual.



WARNING: Use extreme care when handling gasoline. Gasoline is extremely flammable and the vapors are explosive. Never fuel the machine indoors or while the engine is hot or running. Extinguish cigarettes, cigars, pipes and other sources of ignition.

Before Starting Mower

Charging the Battery (Model E977 only)

IMPORTANT: Use only the battery charger supplied with this mower.



WARNING: The battery contains corrosive fluid and toxic material; handle with care. Keep away from children. Do not puncture, disassemble, mutilate or incinerate the battery. Explosive gases could be vented during charging or discharging. Use in a well ventilated area, away from sources of ignition.

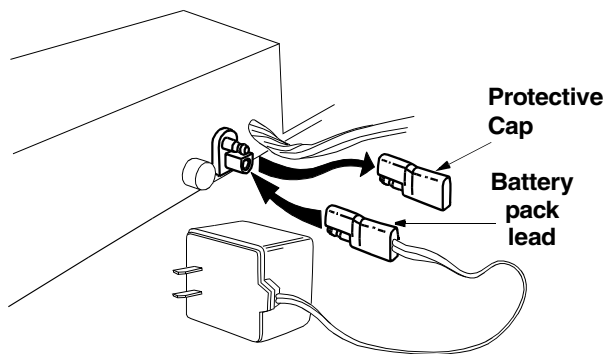

Figure 11

- Remove the protective cap from the end of the battery pack lead. *Always plug charger lead into battery pack lead first, and then insert battery charger plug into 120 volt standard household*

outlet. See Figure 11. Follow this order of action every time you charge the battery.

- Charge battery for 16 hours before initial use. **Do not charge longer than 20 hours.**
- After charging, disconnect battery charger plug from household outlet first, then disconnect charger lead from battery pack lead.



WARNING: Do not remove the battery pack from the handle panel for any reason other than replacement. When replacing the battery pack, refer to instructions on page 16.

- Attach spark plug wire to spark plug. Make certain the metal cap on the end of the spark plug wire (inside the rubber boot) is fastened securely over the metal tip on the spark plug.
- Check for proper drive clutch operation using the neutral adjustment test described below.

Neutral Adjustment Test

To perform the neutral adjustment test, answer the following questions.

- With the drive clutch control released, push mower forward and pull it backward. Does it move freely?
- Squeeze the drive clutch control and pull the mower backward. Do the rear wheels lock?
- Is the drive clutch control cable free of kinks or sharp bends?
- If you answered “yes” to all three questions, your mower passed the test and you can start your mower.
- If you answered “no” to any of the three questions, you will have to adjust the drive clutch control as instructed in the ADJUSTMENT SECTION.

Starting Engine



WARNING: Be sure no one other than the operator is standing near the lawn mower while starting engine or operating mower.

WARNING: Never run engine indoors or in enclosed, poorly ventilated areas. Engine exhaust contains carbon monoxide, an odorless and deadly gas.

WARNING: Keep hands, feet, hair and loose clothing away from any moving parts on engine and lawn mower.

WARNING: When starting the unit for the first time, face the mower against a wall or a fence. Start the unit and if it shows any signs of motion while the drive clutch control is still disengaged, shut engine off immediately.

- Push primer once. Do not prime to restart a warm engine after a short shutdown.
- Standing behind the mower, depress the blade control handle and hold it against the upper handle.
- **Electric Start:** Turn the ignition key to the right to start the engine. Release the key after the engine starts.
- **Recoil Start:** Grasp starter handle and pull rope out slowly until engine reaches start of compression cycle (rope will pull slightly harder at this point). Let the rope rewind slowly. Pull rope with a rapid, continuous, full arm stroke. Keeping a firm grip on the starter handle, let the rope rewind slowly.

Stopping Engine

- Release blade control handle to stop the engine and the blade.
- Disconnect spark plug wire and move away from spark plug to prevent accidental starting.

Using Your Lawn Mower



WARNING: Never operate the mower unless the hooks on the grasscatcher are seated in the slots on the handle bracket assemblies, and the rear discharge door rests firmly against the top of the grasscatcher.

- **Do not** operate the mower without any one of the mulching baffle, discharge chute or grass catcher properly installed.



WARNING: Be sure that the lawn is clear of stones, sticks, wire, or other objects which could damage lawn mower or engine. Such objects could be accidentally thrown by the mower in any direction and cause serious personal injury to the operator and others.

- *For best results, do not cut wet grass.* It may stick to the underside of the mower, preventing proper discharge of grass clippings, and could cause you to slip and fall. New grass or thick grass may require a narrower cut.

- For a *healthy lawn*, always cut off one-third or less of the total length of the grass. Lawn should be trimmed in fall as long as there is growth.

IMPORTANT: Move the shift lever only when the engine is running. Changing the shift lever setting with the engine off can cause damage to the mower.



WARNING: If the mower strikes a foreign object, stop the engine. Remove spark plug wire from the spark plug and thoroughly inspect for any damage. Repair the damage promptly before restarting and operating the mower.

Mulching

For effective mulching, do not cut wet grass. New or thick grass may require a narrower cut. If the grass has grown in excess of 4", mulching is not recommended. Mow using the side discharge to reduce the grass height to 3.25" maximum before mulching.

Bagging Grass Clippings

You can use the grass catcher bag to collect clippings while you are operating the mower.

- Attach grass catcher following instructions on page 8 of this manual. Grass clippings will automatically collect in the bag as you run the mower.
- Operate the mower till the grass bag is full.
- Stop engine completely by releasing the blade control handle. Make sure that the unit has come to a complete stop.
- While holding the grass bag by both the rear handle and the lower handle, lift the grass bag straight up off the adapter. The chute door will move the rope out of the way of the bag.
- Continue to hold the lower handle and raise the rear of the grass bag up toward your chest. The grass bag will open and the grass clippings will disperse. When replacing the grass bag, be sure the top of the bag rests on the wire support between the handles.

SECTION 6: MAKING ADJUSTMENTS



WARNING: Do not at any time make any adjustments without first stopping engine and disconnecting spark plug wire.

Handle Height

Your mower is shipped with the handle in the higher height position. To lower the height, proceed as follows:

- Remove the starter rope from the rope guide.
- Remove the wing nuts and carriage bolts securing the upper handle. Remove and lay the upper handle out of the way, being careful not to bend or kink the cables.
- Remove the hairpin clips from the weld pins on the handle brackets and remove the wing nuts and carriage bolts from the upper hole on the handle mounting bracket.

- Press out on the legs of the lower handle and remove lower handle from the mower.
- Turn lower handle around so the notch on the bottom of the lower handle is facing forward. See Figure 12.

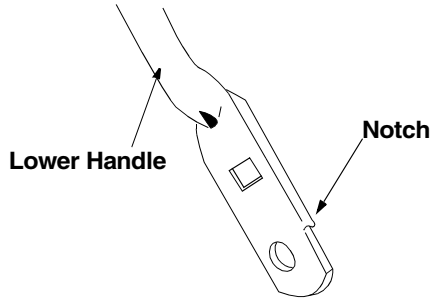

Figure 12

- Reassemble the handles, placing the bottom holes in the handle over the weld pins in the handle mounting bracket.
- Place the hairpin clips in the inner holes in the weld pins and insert the carriage bolts through the upper hole on the handle mounting bracket and secure with plastic wing nuts.
- Reassemble the upper handle to the lower handle.
- Attach the starter rope as instructed on page 8.

Cutting Height

Your mower is shipped with the cutting height in the lowest position. The cutting height adjustment lever is located above the left rear wheel. To adjust the cutting height, proceed as follows:

- Pull the lever out and away from the mower and then move it forward or backward to another slot. For rough or uneven lawns, move the height adjustment lever to a higher position. This will help stop scalping.

Drive Clutch Control

The adjustment wheel is located in the drive clutch control handle housing and is used to tighten or loosen the drive belt. You will have to adjust the drive clutch control if any of the following happens:

1. The mower does not propel itself with the drive clutch engaged.
 2. The mower's drive wheels hesitate with the drive clutch engaged.
- To resolve the above problems, rotate the adjustment wheel with your fingers: clockwise to tighten the cable and counter-clockwise to loosen the cable. See Figure 13.

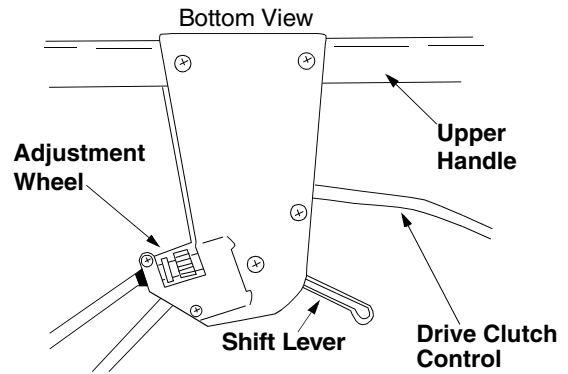

Figure 13

NOTE: For some people the drive clutch control may not be in a comfortable position. You can adjust the handle out by tightening the adjustment wheel.

Shift Lever Cable

Periodic adjustment of the six speed shift cable may be necessary due to normal wear on the cable. Adjustment is needed if all six speeds do not work.

The adjustable cable bracket is located on the left side of the mower beside the engine. See Figure 14.

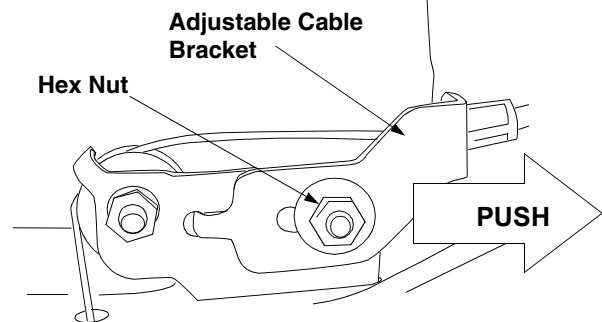

Figure 14

- Start engine and place shift lever in the sixth speed position. Refer to Figure 13.
- Stop engine and disconnect spark plug wire and ground it against engine.
- Loosen hex nut which secures the adjustable cable bracket. See Figure 14.
- Push back on the adjustable cable bracket and tighten hex nut.

Engine Adjustments

Refer to the engine manual for these adjustments.

SECTION 7: MAINTAINING YOUR LAWN MOWER



WARNING: Always stop the engine and disconnect the spark plug wire before performing any maintenance work or adjustments on your lawn mower.

Cleaning Mower

The underside of the mower deck should be cleaned after each use to prevent any build-up of debris. If allowed to accumulate, it will cause rust and corrosion.

NOTE: We do not recommend the use of pressure washers or garden hose to clean your unit. These may cause damage to electric components, spindles, pulleys, bearings, or the engine. The use of water will result in shortened life and reduce serviceability.

- Disconnect spark plug wire.
- Drain the gasoline from the lawn mower, or place a piece of plastic under the gas cap.
- Tip the mower so that it rests on the housing. Keep the side with the air cleaner facing *up*. Hold the mower firmly.
- Scrape and clean the underside of the deck with a suitable tool. Do *not* spray with water.
- Put the mower back on its wheels on the ground. If you had put plastic under the gas cap, make sure to remove it now.



WARNING: Never tip the mower more than 90 degrees in any directions and do not leave the mower tipped for any length of time. Oil can drain into the upper part of the engine causing a starting problem.

Engine Care

A list of key maintenance jobs required for good performance by the mower is given below. Follow the accompanying engine manual for detailed list and instructions.

- Change engine oil regularly, as instructed in the engine manual. Check oil level before starting engine every time. Change oil while the engine is warm, not hot or cold.
- Service foam filter in the air cleaner every 25 hours of use and replace the paper filter component every 100 hours. You may have to service the air filter more frequently if you are operating the mower under extremely dusty conditions.
- Clean the engine periodically. Remove dirt and debris with a cloth or brush.
- Clean the spark plug and reset the gap to .030" at least once a season. Refer to the engine manual for correct spark plug type.

- Inspect muffler periodically, and replace if necessary. Damaged mufflers or spark arresters can create a fire hazard. Make sure to avoid muffler and surrounding areas while the mower engine is hot because temperature of these areas of the engine may exceed 150° F.

Lubrication

Refer to the lubrication chart in Figure 15.

Blade Control Handle

- Lubricate the pivot points on the blade control handle at least once a season with light oil. The blade control must operate freely in both directions.

Rear Discharge Door

- Lubricate the torsion spring and the pivot point on each end of the rear discharge door using a light oil. This will prevent rusting of the discharge door.

Wheels

- Lubricate the wheels and bearings, if so equipped, at least once a season with light oil or engine oil. Also, if the wheels are removed for any reason, lubricate the surface of the axle bolt and the inner surface of the wheel with light oil.

Engine

- Follow the engine manual instructions and recommended schedule for lubricating engine components.

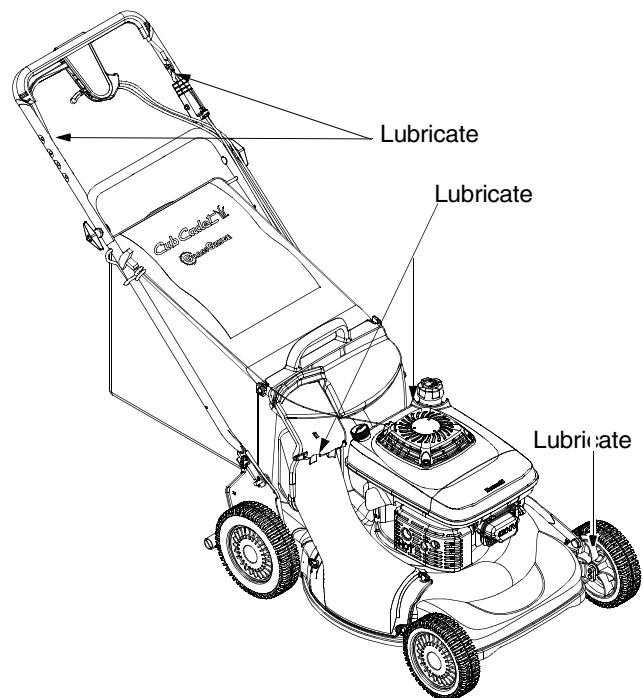

Figure 15: Lubrication Chart

SECTION 8: SERVICING THE MOWER



WARNING: Always stop the engine and disconnect the spark plug wire before performing any maintenance work or adjustments on your lawn mower.

Blade Care



WARNING: When removing the cutting blade for sharpening or replacement, protect your hands with a pair of heavy gloves or use a heavy rag to hold the blade.

Periodically inspect the blade adapter for cracks, especially if you strike a foreign object. Replace when necessary.

Removing the Blade

- Disconnect spark plug wire from spark plug.
- Turn mower on its side making sure that the air filter and the carburetor are up.
- Remove the bolt and the blade bell support which hold the blade and the blade adapter to the engine crankshaft. See Figure 16.
- Remove the blade and the adapter from the crankshaft.

Sharpening the Blade

- The blade can be sharpened with a file or on a grinding wheel. Do not attempt to sharpen the blade while it is still on the mower.
- Follow the original angle of grind as a guide. Make sure that each cutting edge receives an equal amount of grinding to prevent an unbalanced blade.



WARNING: An unbalanced blade will cause excessive vibration when rotating at high speeds. It may cause damage to the mower, and could break causing personal injury.

Balancing the Blade

- The blade can be tested by balancing it on a round shaft screwdriver. Remove metal from the heavy side until it balances evenly. It is recommended that the blade always be removed from the adapter when testing for balance.

Installing the Blade

- Before reinstalling the blade and the blade adapter to the unit, lubricate the engine crankshaft and the inner surface of the blade adapter with light oil.
- Be sure to install the blade with the side of the blade marked "Bottom" (or with part number) facing the ground when the mower is in the operating position.
- Slide the blade adapter onto the engine crankshaft.

- Place the blade on the adapter. Be certain the blade is aligned and seated on the blade adapter flanges.
- Place blade bell support on blade. Make sure the notches on the blade bell support are aligned with small holes in the blade.
- Replace hex bolt and tighten hex bolt to torque: 450 in. lbs. min., 600 in. lbs. max.

NOTE: To ensure safe operation of your mower, periodically check the blade bolt for correct torque.

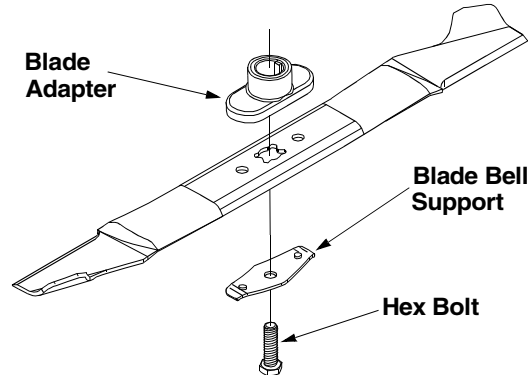

Figure 16

Drive Belt Replacement

- Disconnect the spark plug wire and ground it against the engine.
- Drain the fuel tank or place a piece of plastic beneath the cap to prevent gasoline leakage.
- Place shift lever in the first position and tip the mower on its side with air filter facing up.
- Remove the center bolt which secures the blade to the crankshaft followed by blade bell support, blade, and blade adapter.
- Move the cutting height adjustment to the highest position.
- Remove the three hex screws holding the baffle to the deck and pivot baffle towards the rear of the mower. See Figure 17.

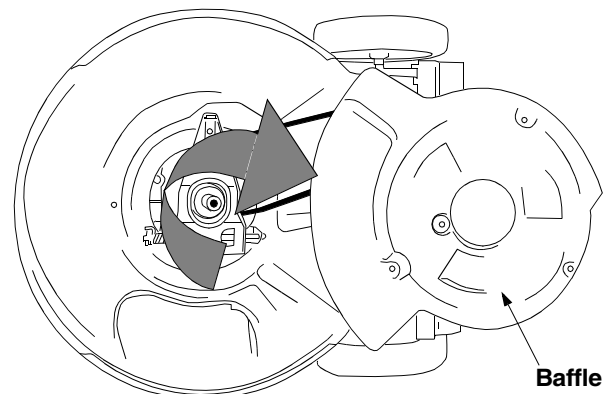

Figure 17

- Remove the hex bolt from the rear of unit holding the transmission to the mower housing. See Figure 18.

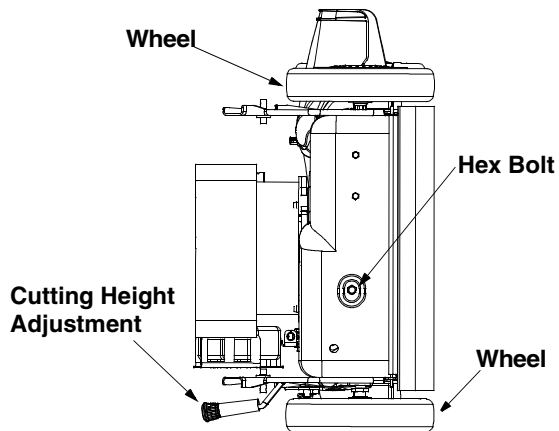

Figure 18

- Tilt the transmission forward and loosen the idler pulley bolt and lock nut half a turn. See Figure 19.

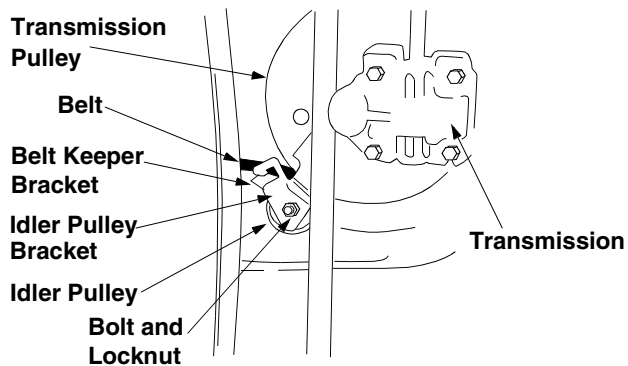

Figure 19

- Using a pair of pliers, pull back and rotate belt keeper bracket from the slot on the idler pulley.
- Slide the belt out from between the belt keeper bracket and the idler pulley. See Figure 19.
- Squeeze the belt together and push it forward, while pressing the control arm inward towards the deck and remove the six speed cable from the slot. See Figure 20.

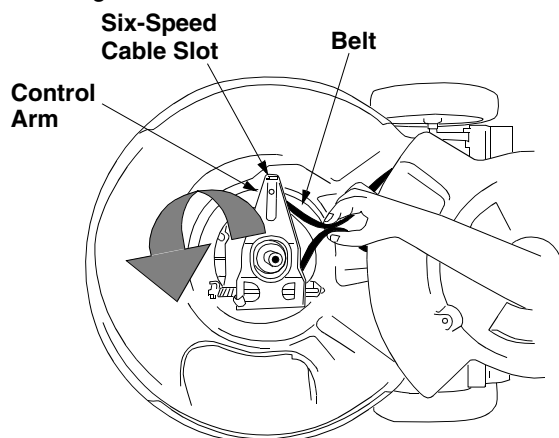

Figure 20

- Pivot the control arm down away from the pulley and belt.
- Lift off the lower pulley assembly and remove the old belt from around the crankshaft.
- Place the new belt over the transmission pulley. Start the belt in the pulley groove and rotate the pulley until the belt is seated in transmission pulley.
- Place the belt between the idler pulley and the belt keeper bracket.
- Using pliers, rotate the belt keeper bracket so that it snaps into slot on the idler bracket.
- Tighten the idler pulley bolt and lock nut half a turn.
- Place the belt between the two pulley halves on the crankshaft. Make sure to route the belt inside the belt guard pin. See Figure 21.

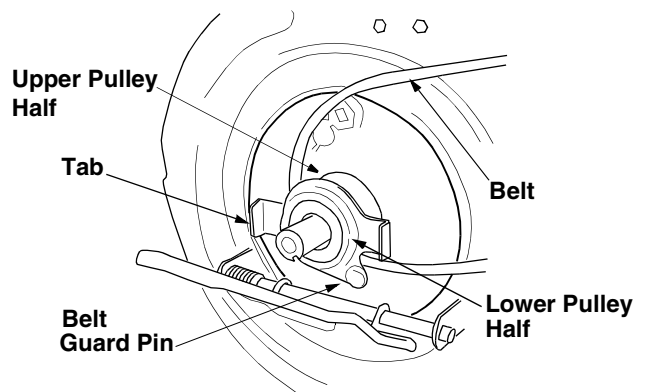

Figure 21

IMPORTANT: When replacing the belt, do not disassemble the lower pulley assembly.

- Pinch both sides of the belt together so that the belt is not in the pulley groove, and the lower pulley can be pushed towards the engine. See Figure 22.

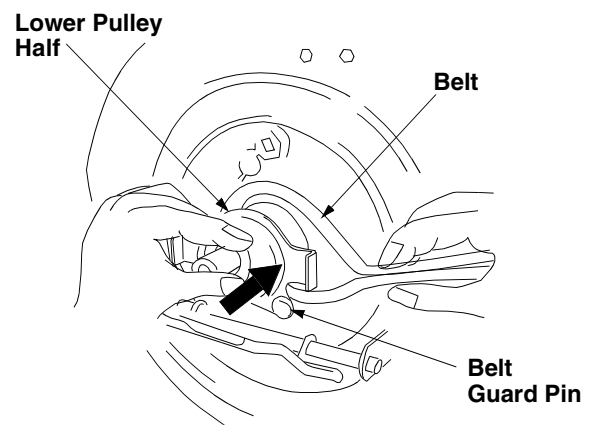

Figure 22

- Pivot the control arm back to its original position and reinstall the six-speed cable into the slot. See Figure 23.

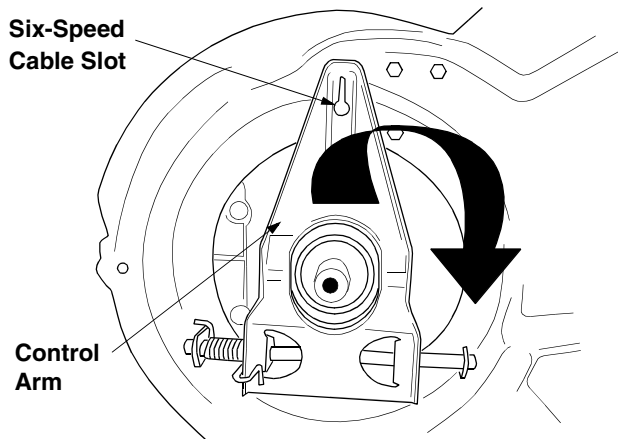

Figure 23

- Make sure the belt is routed inside the pulley halves and the belt guard pin.
- Reinstall the bolt securing transmission to rear mower housing.
- Pivot the baffle back to its original position and secure with three hex screws removed earlier.
- Lightly lubricate the inside of the blade adapter and reinstall the spacer, wave washer, blade adapter assembly, and blade in the correct order.
- Tighten the hex bolt to secure the blade to torque: 450-600 in. lbs.

Replacing Rear Flap

- To remove rear flap, cut off the flat end of the wire rod which secures it to the deck.

- Attach the new flap and new rod to deck, bending the ends of the new rod over to secure to deck.

Replacing Battery Pack

(Model E977 only)

- Remove the battery pack from the handle panel for replacement only. Do not separate the batteries for any reason. Dispose of batteries properly.
- When replacing battery pack in handle panel, battery pack **must** be positioned with the positive terminal to the right side and the negative terminal to the left side of the panel. **Replacing the battery pack incorrectly will cause serious damage.** The positive lead on the wire harness has the smaller connector. Connect the positive lead to the positive side of the battery pack, then connect the negative side.



WARNING: Batteries contain sulfuric acid which may cause burns. Do not short circuit or mutilate batteries in any way. Do not put batteries in fire as these may burst or release toxic materials.

In-line Fuse

(Model E977 only)

The unit is equipped with an in-line fuse. If the unit fails to start, check the fuse inside the battery cover by turning the end of the fuse holder and removing from the battery cover. Replace with standard automotive 7-1/2 amp fuse.

SECTION 9: OFF-SEASON STORAGE

Storing Your Lawn Mower

The following steps should be taken to prepare your lawn mower for storage.

- Clean and lubricate mower thoroughly as described in the lubrication instructions.

IMPORTANT: We do not recommend the use of a pressure washer or garden hose to clean your unit.

- Refer to engine manual for correct engine storage instructions.

- Coat mower's cutting blade with chassis grease to prevent rusting.
- Store mower in a dry, clean area. Do not store next to corrosive materials, such as fertilizer.

NOTE: When storing any type of power equipment in a poorly ventilated or metal storage shed, care should be taken to rust-proof the equipment. Using a light oil or silicone, coat the equipment, especially cables and all moving parts.

SECTION 10: TROUBLESHOOTING

Problem	Cause	Remedy
Engine fails to start	<ol style="list-style-type: none"> 1. Blade control handle disengaged. 2. Spark plug wire disconnected. 3. Fuel tank empty or stale fuel. 4. Blocked fuel line. 5. Faulty spark plug. 6. Engine flooded 	<ol style="list-style-type: none"> 1. Engage blade control handle. 2. Connect wire to spark plug. 3. Fill tank with clean, fresh gasoline. 4. Clean fuel line. 5. Clean, adjust gap, or replace. 6. Wait a few minutes to restart, do not prime.
Engine runs erratic	<ol style="list-style-type: none"> 1. Spark plug wire loose. 2. Blocked fuel line or stale fuel. 3. Vent in gas plugged. 4. Water or dirt in fuel system. 5. Dirty air cleaner. 6. Carburetor out of adjustment. 	<ol style="list-style-type: none"> 1. Connect and tighten spark plug wire. 2. Clean fuel line; fill tank with clean, fresh gasoline 3. Clear vent. 4. Drain fuel tank. Refill with fresh fuel. 5. Clean air cleaner. 6. Adjust carburetor.
Engine overheats	<ol style="list-style-type: none"> 1. Engine oil level low. 2. Air flow restricted. 3. Carburetor not adjusted properly. 	<ol style="list-style-type: none"> 1. Fill crankcase with proper oil. 2. Remove blower housing and clean. 3. Adjust carburetor.
Occasional skip (hesitates) at high speed	<ol style="list-style-type: none"> 1. Spark plug gap too close. 	<ol style="list-style-type: none"> 1. Adjust gap to .030".
Idles poorly	<ol style="list-style-type: none"> 1. Spark plug fouled, faulty or gap too wide. 2. Carburetor improperly adjusted. 3. Dirty air cleaner. 	<ol style="list-style-type: none"> 1. Reset gap to .030" or replace spark plug. 2. Adjust carburetor. 3. Clean air cleaner.
Excessive vibration	<ol style="list-style-type: none"> 1. Cutting blade loose or unbalanced. 2. Bent cutting blade. 	<ol style="list-style-type: none"> 1. Tighten blade and adapter. Balance blade. 2. Replace blade.
Mower will not mulch grass	<ol style="list-style-type: none"> 1. Wet grass. 2. Excessively high grass. 3. Dull blade. 	<ol style="list-style-type: none"> 1. Do not mow when grass is wet; wait until later to cut. 2. Mow once at a high cutting height, then mow again at desired height or make a narrower cutting path. 3. Sharpen or replace blade.
Uneven cut	<ol style="list-style-type: none"> 1. Wheels not positioned correctly. 2. Dull blade. 	<ol style="list-style-type: none"> 1. Place all four wheels in same height position. 2. Sharpen or replace blade.

SECTION 11: PARTS LIST FOR MODELS 977 & E977

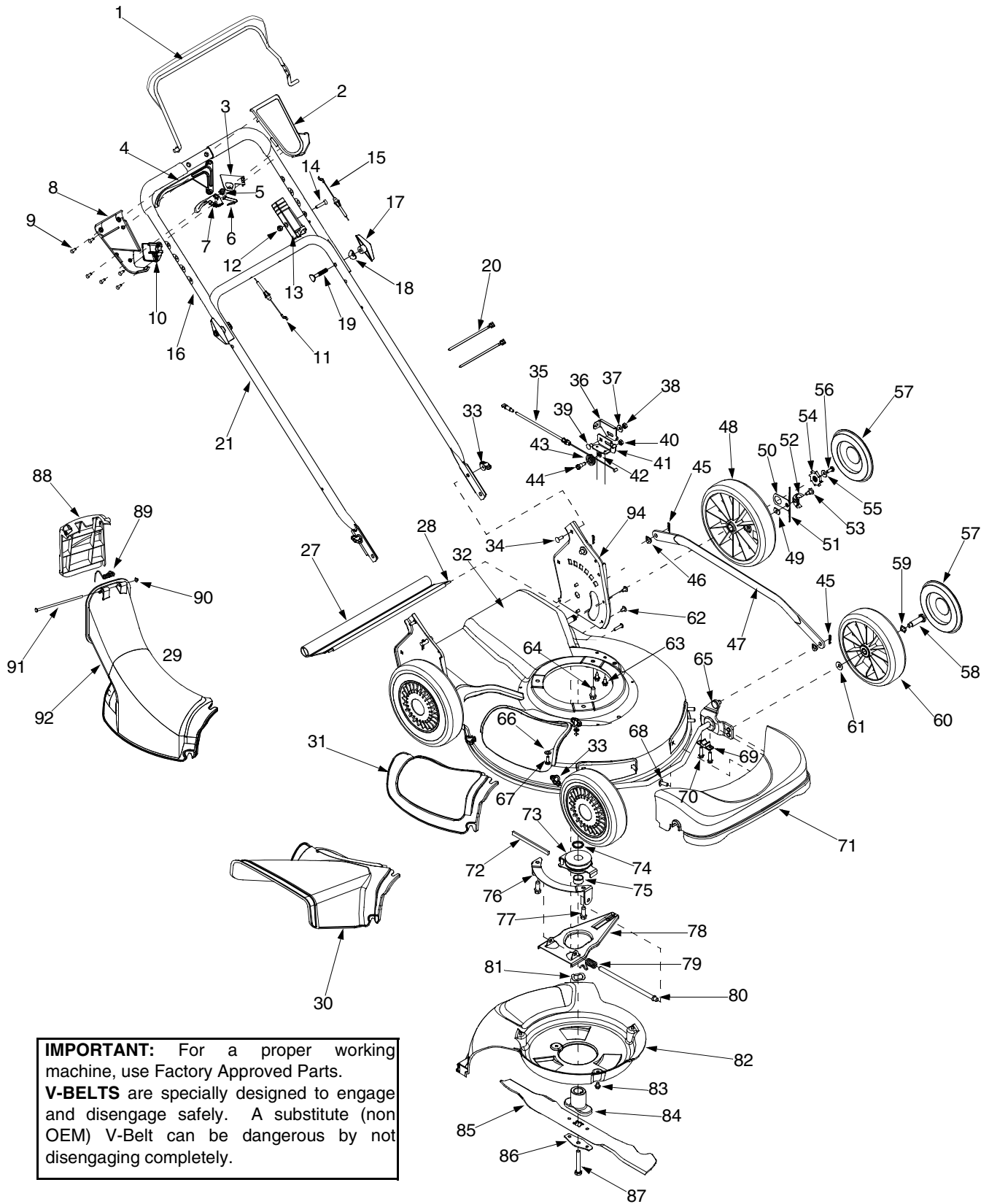

IMPORTANT: For a proper working machine, use Factory Approved Parts. **V-BELTS** are specially designed to engage and disengage safely. A substitute (non OEM) V-Belt can be dangerous by not disengaging completely.

Models 977 & E977

Ref. No.	Part No.	Description	Ref. No.	Part No.	Description
1.	647-04008	Control Handle	52.	748-0381	Pawl RH
2.	731-0904A	Upper Control Handle		748-0188B	Pawl LH
3.	16864	6 Spd. Rack Cable Bracket	53.	738-0137A	Shld Screw .340 ID x .285 OD
4.	731-0620	Control Lever	54.	748-0318	Wheel Ratchet
5.	713-0397	Gear Insert	55.	736-0270	Bell Washer .265 ID x .75 OD
6.	732-0627	Shift Lever Spring	56.	710-0751	Hex Cap Screw 1/4-20 x .620
7.	731-0924	6 Speed Shift Lever	57.	731-0982A	Hubcap
8.	731-0905A	Lower Control Housing	58.	738-0102	Shoulder Screw .498 x 1.445
9.	710-1667A	C Sunk Tap Screw #10 x .75 Lg	59.	736-0504	Wave Washer .510 ID x .750 OD
10.	731-0906	Cable Mounting Cap	60.	734-2008A	Wheel 8 x 2.125
11.	746-0711A	Drive Cable 51.0	61.	736-0105	Spring Washer .401 ID x .870 OD
12.	712-0324	Top Lock Nut 1/4-20	62.	710-1348	Screw 1/4-14 x .500
13.	746-0883	Control Housing	63.	710-0896	Screw 1/4-14 x .625
14.	710-1270	Oval C-Sunk Screw	64.	710-0654A	Hex Washer Screw 3/8-16 x 1.0
15.	746-04055	Control Cable	65.	611-0064	Front Axle Assembly
16.	749-0439D	Upper Handle	66.	736-0204	Flat Washer .344 ID x .62 OD
17.	720-0284	Wing Nut	67.	710-0703	Carriage Screw 1/4-20 x .75
18.	736-0451	Saddle Washer .320 ID x .830 OD	68.	710-1242	Torx Screw
19.	710-1174	Carriage Bolt 5/16-18 x 2.0	69.	741-0492A	Block Bushing
20.	726-0240	Cable Tie	70.	710-1241	Hex Washer Screw
21.	749-0907B	Lower Handle	71.	731-1836	Front Axle Cover
27.	731-1901	Trail Shield	72.	754-0460	Belt 3/8 x 39.24
28.	732-0842	Trail Shield Wire	73.	656-0613	Pulley Assembly
29.	631-0066	Chute Assembly	74.	750-1071	Sleeve Spacer .88 ID x 1.13 OD
30.	731-1832	Side Discharge Chute	75.	750-1070	Sleeve Spacer .88 ID x 1.00 OD
31.	731-1833	Mulch Cover	76.	782-7597	Pivot Bracket
32.	782-0078B	Deck 21"	77.	710-0654A	Screw 3/8-18 x 1.0
33.	712-0397	Wing Nut	78.	782-7596	Control Arm
34.	710-0703	Carriage Bolt 1/4-20 x .75	79.	732-0807	Torsion Spring
35.	746-0939	6 Speed Cable	80.	711-1114	Pivot Shaft
36.	782-7574A	Cable Adjustment Bracket	81.	736-0526	Wave Washer 1.38 ID x .88 OD
37.	736-0270	Bell Washer .265 ID x .75 OD	82.	731-1828	Baffle
38.	712-0287	Hex Nut 1/4-20	83.	710-0653	Screw 1/4-20 x 3.75
39.	710-0167	Carriage Screw 1/4-20 x .50	84.	753-0609	Blade Adapter Kit
40.	712-0138	Hex Nut 1/4-28	85.	742-0741	21" Mulching Blade
41.	782-7575A	Cable Mounting Bracket	86.	736-0524A	Blade Bell Support
42.	736-0329	Lock Washer 1/4	87.	710-1257	Hex Bolt 3/8-24 x 2.5
43.	756-0625	Roller Cable	88.	731-1874	Chute Door
44.	738-0924	Shoulder Screw .375 ID x 1/4-14	89.	732-0819	Torsion Spring
45.	714-0104	Cotter Pin	90.	726-0111	Push Cap
46.	736-0286	Bowed Washer	91.	747-0965	Pivot Rod
47.	782-0565	Single Lever Control Arm	92.	731-1713B	Discharge Chute
48.	734-2010	Wheel 9 x 2.125	94.	682-3052	Handle Bracket Assembly - RH
49.	712-0414	Top Lock Tab Weld Nut 1/4-20		682-3053	Handle Bracket Assembly - LH
50.	16855	Ratchet Pawl Plate	95.	682-7527	Cup Assembly (Part of #73)
51.	10622B	Plastic Spring Ratchet			

Models 977 & E977

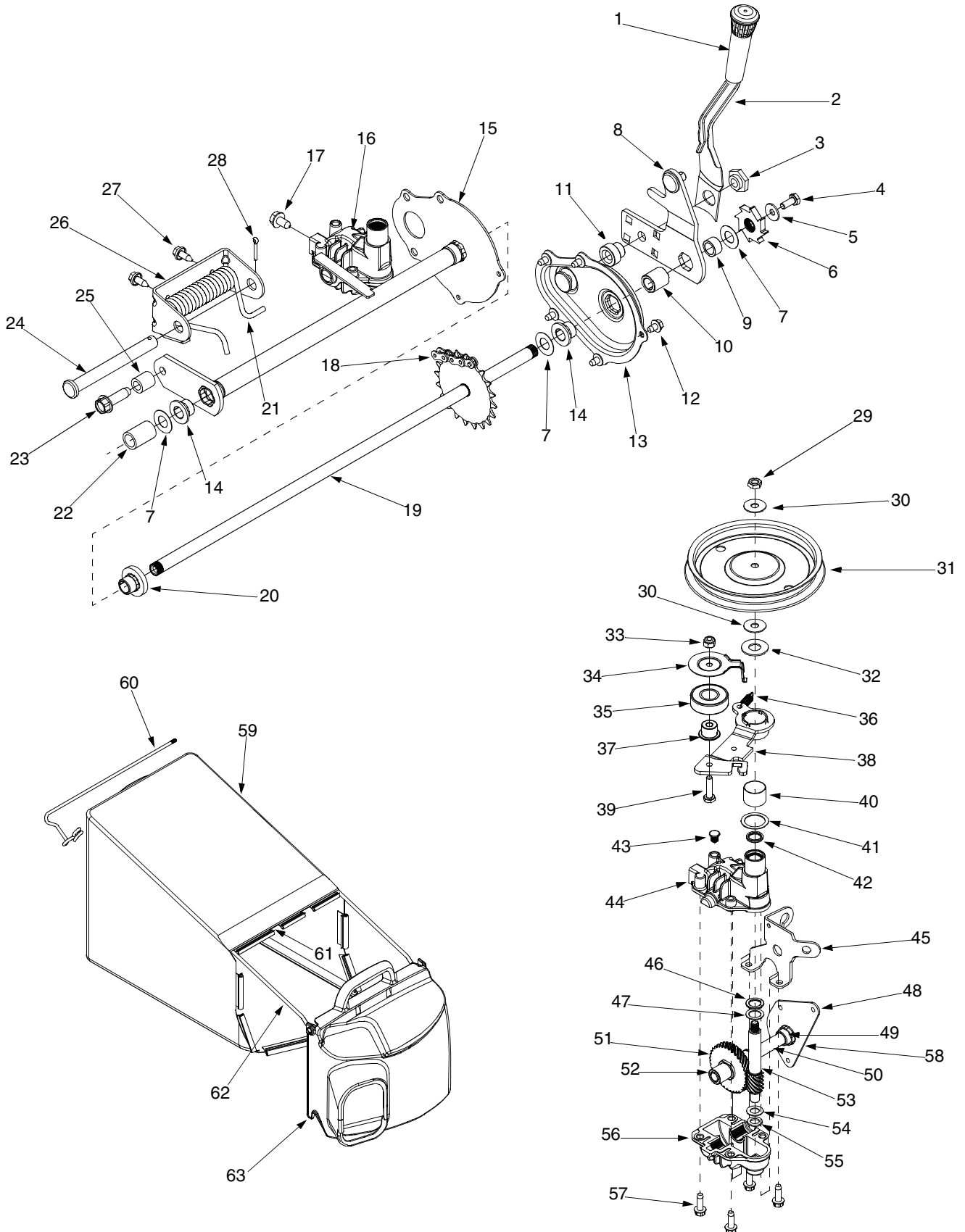

Models 977 & E977

Ref. No.	Part No.	Part Description	Ref. No.	Part No.	Part Description
1.	720-0223	Grip	33.	712-0896	Hex Jam Nut 1/4-28
2.	732-0803A	Spring Lever	34.	782-7598	Belt Keeper
3.	738-0529	Shoulder Nut .825 x .165 Lg.	35.	741-0600	Bearing
4.	710-0751	Cap Screw 1/4-20 x .620	36.	732-0849A	Extension Spring
5.	736-0270	Bell Washer .285 ID x .75 OD	37.	750-1050	Flange Spacer
6.	748-0318	Wheel Ratchet	38.	682-0027A	Idler Bracket Assembly
7.	736-0369	Flat Washer .508 ID x 1.0 OD	39.	710-0299	Hex Cap Screw 1/4-28 x 1.0
8.	682-0531	Pivot Arm Assembly	40.	741-0682A	Bearing Sleeve
9.	750-0515	Spacer .510 ID x .70 OD	41.	736-0570	Flat Washer .885 ID x 1.45 OD
10.	741-0978	Sleeve Bearing .504 ID x .830 OD	42.	721-0329	Oil Seal
11.	750-1056	Shoulder	43.	721-0325	Plug
12.	710-0653	Tap Screw 1/4-20 x .375	44.	618-0253	Upper Housing Assembly
13.	682-7528	Chain Cover Assembly	45.	782-7601A	Cable Bracket
14.	741-0324	Flange Bearing .506 ID x .590 Lg	46.	741-0690	Bearing
15.	682-7526	Transmission Axle Assembly	47.	736-0616	Thrust Washer .504 ID x .70 OD
16.	618-0263A	Transmission Assembly Complete	48.	782-7595	Pivot Bracket
17.	710-0604A	Hex Screw 5/16-18	49.	741-0324	Flange Bearing
18.	713-0453	Chain	50.	711-1168	Output Shaft 6T
19.	638-0012	Rear Axle Assembly	51.	717-1469	Gear 34T
20.	741-0522	Flange Bearing .506 ID x .715 Lg	52.	741-0674	Bearing
21.	732-0832	Torsion Spring	53.	717-1487	Pinion Shaft 10T
22.	750-0151	Spacer .550 ID x .750 OD	54.	736-0314	Thrust Washer 3/8 x .70
23.	710-1315	Screw 3/8-16 x .25	55.	736-0569	Thrust Washer .388 x .625
24.	711-0835	Clevis Pin .50 Dia x 4.82 Lg.	56.	618-0252	Lower Housing Assembly
25.	750-0807	Spacer .385 ID x .624 OD	57.	710-0642	Hex Screw 1/2-20 x .75
26.	782-0568	Hgt Adjustment Spring Bracket	58.	611-0066	Shaft Assembly
27.	710-1652	Screw 1/4-14 x .825	59.	664-0121	Grassbag
28.	714-0474	Cotter Pin	60.	747-0940A	Support Rod w/ Rope Guide
29.	712-3025	Hex Jam Nut 5/16-24	61.	747-0939	Pivot Rod
30.	736-0425	Bell Washer .325 ID x .930 OD	62.	747-0937	Grassbag Frame
31.	756-0656	Pulley	63.	631-0071	Grassbag Cover
32.	736-3084	Flat Washer .510 ID x 1.120 OD			

Model E977

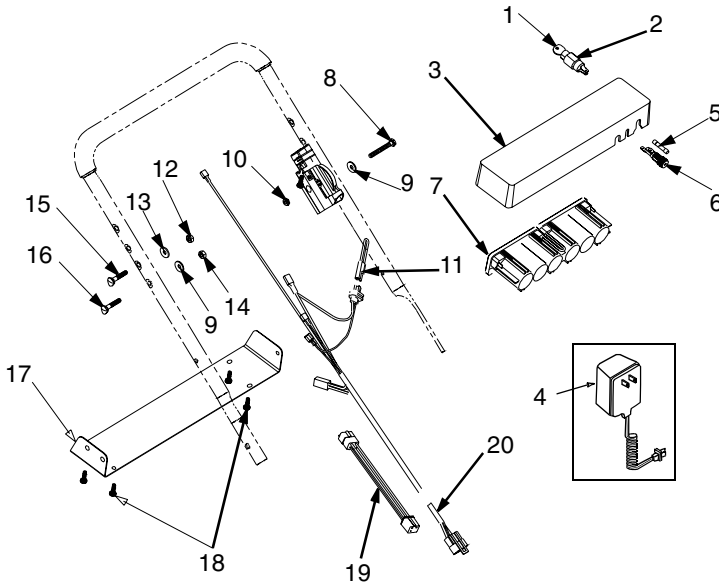

Ref. No.	Part No.	Description
1	725-0201	Ignition Key
2	725-0873	Key Switch
3	731-0891A	Battery Tray
4	725-0727	Battery Charger
5	725-0298	Fuse 7.5 Amp
6	725-1428	Fuse Holder
7	725-1276	Battery 12V
8	710-0501	Hex Screw:1/4-20:2.0
9	736-0270	Bell Washer
10	712-0329	Special Hex Nut 5/16-18
11	725-1206	Plug
12	712-0267	Nut 5/16-18
13	736-0242	Bell Washer
14	712-0287	Hex Nut 1/4-20
15	710-1250	Carriage Bolt
16	710-0111	Carriage Screw
17	782-9012	Lower Battery Tray
18	710-0969	Tapp Screw
19	725-1538	Harness Extension
20	625-0022	Harness

Safety & Decorative Labels

Some of the labels found on your mower are represented here with the corresponding part numbers. Please use part numbers when ordering replacement labels.

777S30118



777I20291

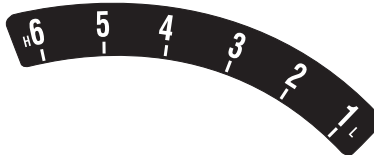

777S30128



777S30116



777S30145



777D06697



Engine Manual for Kawasaki Engine

SAFETY AWARENESS



WARNING: Whenever you see the symbols shown on the left, heed their instructions! Always follow safe operating and maintenance practices.

FORWARD

We wish to thank you for purchasing this Kawasaki engine. Please read this Owner's manual carefully before starting your new engine so that you will be thoroughly familiar with the proper operation of your engine's control, its features, capabilities and limitations. Also read the manual of the equipment to which this engine is attached. To ensure a long, trouble-free life for your engine, give it the proper care and maintenance described in this manual.

Always keep this manual at your fingertip so that you can refer to it whenever you need information. This manual should be considered a permanent part of the engine and should remain with the engine when it is sold. All rights reserved. No part of this publication may be reproduced without our prior written permission. This publication includes the latest information available at the time of printing. However, there may be minor differences between the actual product and illustrations and text in this manual. All products are subject to change without prior notice or obligation.

EMISSION CONTROL INFORMATION	24
GENERAL INFORMATION	26
FUEL AND OIL RECOMMENDATIONS	27
PREPARATION	27
Fuel	27
Engine Oil	27
STARTING	28
Starting Engine	28
OPERATING	28
Anti-engine inclination	28
STOPPING	28
Stopping Engine	28
ADJUSTMENT	29
Engine Speed Adjustment	29
MAINTENANCE	29
Periodic Maintenance Chart	29
Oil Level Check	29
Oil Change	29
Air Cleaner Service	30
Spark Plug Service	30
STORAGE	31
TROUBLESHOOTING GUIDE	33
ENVIRONMENTAL PROTECTION	33
SPECIFICATIONS	33

READ THIS FIRST



WARNING: Never allow children to operate the engine or equipment.

Keep people and pets out of area where you are using the engine or equipment.

Never wear loose, torn, or bulky clothing. It may catch on moving parts or controls, leading to the risk of accident.

Never consume alcohol or drug before or while operating this engine.

Do not run the engine in a closed area. Exhaust gas contains carbon monoxide, an odorless and deadly poison.

Gasoline is extremely flammable and can be explosive under certain condition.

Stop engine and allow the engine to cool before refueling.

Do not smoke. Make sure area is well ventilated and free from any source of flame or sparks including the pilot light of any appliance while refueling, servicing fuel system, draining gasoline and/or adjusting carburetor.

Do not fill the tank so the fuel level rises into the filler neck. If the tank is overfilled, heat may cause the fuel to expand and overflow through the vents in the tank cap.

Wipe off any spilled gasoline immediately.

To prevent fire hazard:

Keep the engine at least 1 m (3.3 ft.) away from buildings, obstructions and other burnable objects.

Do not place flammable objects close to the engine.

Do not expose combustible materials to the engine exhaust.

Do not use the engine on any forest covered, bush covered or grass covered unimproved land unless spark arrester is installed on the muffler.

To avoid getting an electric shock, do not touch spark plug, plug cap or spark plug lead during engine running.

To avoid a serious burn, do not touch a hot engine or muffler. The engine becomes hot during operation. Before you service or remove parts, stop engine and allow the engine to cool.

Do not place hands or feet near moving or rotating parts.

Do not run engine at excessive speeds. This may result in injury.

Always remove the spark plug lead from spark plug when servicing the engine to prevent accidental starting.

Emission Control Information

Fuel Information

THIS ENGINE IS CERTIFIED TO OPERATE ON UNLEADED REGULAR GRADE GASOLINE ONLY.

A minimum of 87 octane of the antiknock index is recommended. The antiknock index is posted on service station pumps in the U.S.A.

To protect the environment in which we all live, Kawasaki has incorporated an exhaust emission control system in compliance with applicable regulations of the United States Environmental Protection Agency and the California Air Resources

Board. Also, depending on when your engine was produced, it may have an assigned emissions durability period. * See below for the engine emissions durability period that may apply to your engine.

Exhaust Emission Control System

The exhaust emission control system applied to this engine consists of a fuel system and an ignition system having optimum ignition timing characteristics. The fuel system has been calibrated to provide lean air/fuel mixture characteristics and optimum fuel economy with a suitable air cleaner and exhaust system

A sealed-type crankcase emission control system is also used to eliminate blow-by gasses. The blow-by

gasses are led to a breather chamber through the crankcase and from there to the air cleaner.

Engine Emissions Compliance Period

California

Model Year - 2006 and later Vertical Crankshaft

Durability Period - 500 hours

All Other States

Model Year - 2003 and later (new)

2007 and later (carry over)

Durability Period - 500 hours (Category A)

If your engine has an assigned emissions durability period it will be located on the certification label attached to the engine (IMPORTANT ENGINE INFORMATION).

High Altitude Performance Adjustment Information

To improve the EMISSIONS CONTROL PERFORMANCE of engines operated above 1,000 meters (3,300 feet), Kawasaki recommends the following Environmental Protection Agency (EPA) and the California Air Resources Board (CARB) approved modifications.

NOTE: *When properly performed, these specified modifications only are not considered to be emissions system "tampering" and engine performance is generally unchanged as a result.*

Installation Instructions:

High altitude adjustment requires replacement of carburetor main jet. Installation of these optional parts may be performed by an authorized Kawasaki dealer, or the consumer, following repair recommendations specified in the appropriate Kawasaki Service Bulletin.

Maintenance and Warranty

Proper maintenance is necessary to ensure that your engine will continue to have low emission levels. This Owner's Manual contains those maintenance recommendations for your engine. Those items identified by the Periodic Maintenance Chart are

necessary to ensure compliance with the applicable standards.

As the owner of the engine, you have the responsibility to make sure that the recommended maintenance is carried out according to the instructions in this Owner's Manual at your own expense.

The Kawasaki Limited Emission Control System Warranty requires that you return your engine to an authorized Kawasaki dealer for remedy under warranty. Please read the warranty carefully, and keep it valid by complying with the owner's obligations it contains.

Tampering with Emission Control System Prohibited

Federal law and California State law prohibit the following acts or the causing thereof: (1) the removal or rendering inoperative by any person other than for purposes of maintenance, repair, or replacement, of any device or element of design incorporated into any new engine for the purposes of emission control prior to its sale or delivery to the ultimate purchaser or while it is in use, or (2) the use of the engine after such device or element of design has been removed or rendered inoperative by any person.

Among those acts presumed to constitute tampering are the acts listed below:

Do not tamper with the original emission related parts:

- Carburetor and internal parts
- Spark Plug
- Magneto or electronic ignition system
- Fuel filter element
- Air cleaner elements
- Crankcase
- Cylinder head
- Breather chamber and internal parts
- Intake pipe and tube

General Information

Location of Safety Related Labels

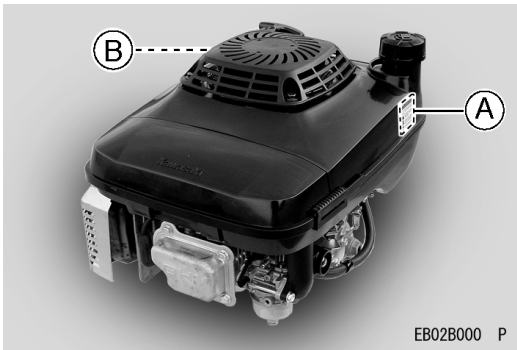
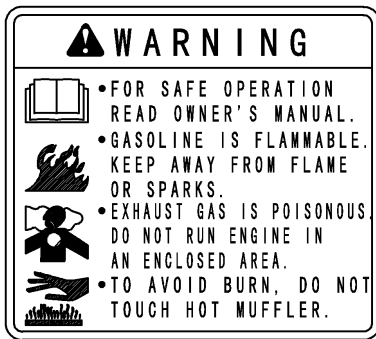

Figure 1

- a. Warning (Refer to)
- b. Engine Maintenance (Refer to)



EB02002BZ2 C



Engine Serial Number

The engine serial number is your only means of identifying your particular engine from others of the same model type. This engine serial number is needed by your dealer when ordering parts. Refer to Figure 2.



Figure 2

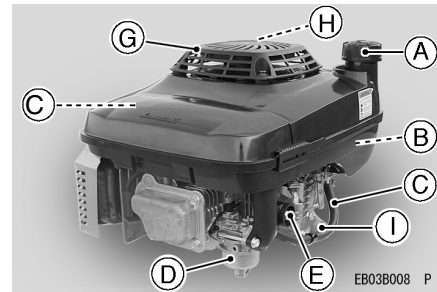

Figure 3

- A. Fuel Tank Cap
- B. Fuel Tank (capacity 2.0L [0.528US gal.])
- C. Fuel Tube
- D. Carburetor
- E. Priming Pump
- F. Air Cleaner
- G. Recoil starter
- H. Recoil Starter Grip
- I. Oil Drain Plugs (engine oil capacity 0.65L [0.69US gal.])

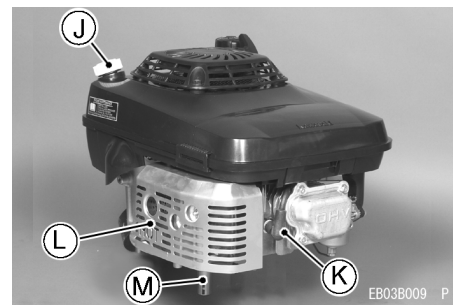

Figure 4

- J. Oil Gauge / Filler Cap
- K. Spark Plug Cap / Spark Plug
- L. Muffler
- M. P.T.O. Shaft

Tune-up Specifications

ITEM	SPECIFICATION
• Valve Clearance	• IN 0.12mm(0.005 in.) • EX 0.12mm{0.005 in.}
• Ignition Timing	• Unadjustable
• High Idle Speed	• 3200 r/min (rpm)
• Spark Plug Gap	• 0.7- 0.8mm(0.028-0.032 in.)
• Other Specifications	• NO OTHER ADJUSTMENT NEEDED

Fuel And Oil Recommendations

Fuel

Use only clean, fresh, unleaded regular grade gasoline.

Octane Rating

The octane rating of a gasoline is a measure of its resistance to "knocking". Use a minimum of 87 octane of the antiknock index is recommended. The antiknock index is posted on service station pumps in the U.S.A.

NOTE: If "knocking or pinging" occurs, use a different brand of gasoline or higher octane rating.

CAUTION: Do not mix oil with gasoline

Oxygenated Fuel

Oxygenates (either ethanol or MTBE) are added to the gasoline. If you use the oxygenated fuel be sure it is unleaded and meets the minimum octane rating requirement. The following are the EPA approved percentages of fuel oxygenates.

ETHANOL: (Ethyl or Grain Alcohol)

You may use gasoline containing up to 10% ethanol by volume.

MTBE: (Methyl Tertiary Butyl Ether)

You may use gasoline containing up to 15% MTBE by volume.

METHANOL: (Methyl or Wood Alcohol) 5% by volume

You may use gasoline containing up to 5% methanol by volume, as long as it also contains co solvents and corrosion inhibitors to protect the fuel system.

Gasoline containing more than 5% methanol by volume may cause starting and/or performance problems. It may also damage metal, rubber, and plastic parts of your fuel system.



WARNING: Gasoline is extremely flammable and can be explosive under certain conditions. Do not smoke. Make sure the area is well ventilated and free from any source of flame or sparks; this includes any appliance with a pilot light. Never fill the tank so the fuel level rises into the filler neck. If the tank is overfilled, heat may cause the fuel to expand and overflow through the vents in the tank cap.

Engine Oil

The following engine oils are recommended:

API Service Classification: SF, SG, SH, or SJ.

Oil Viscosity

Choose the viscosity according to the temperature as follows:

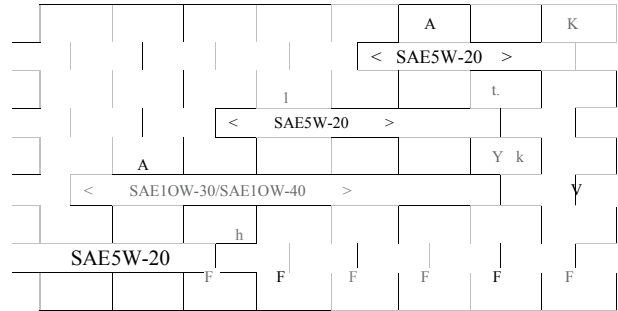

Figure 5

NOTE: Using multi grade oils (5W-20, 10W-30, and 10W-40) will increase oil consumption. Check oil level more frequently when using them.

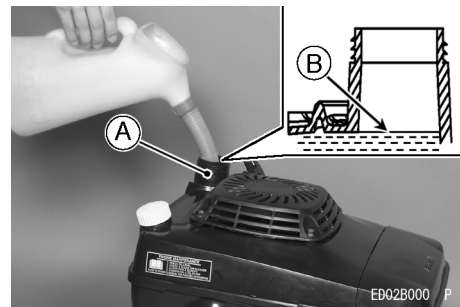

Figure 6

Preparation

Fuel

- Level the engine (equipment) before fueling.
- Remove the fuel tank cap.
- Slowly pour fuel into the fuel tank to bottom (B) of the filler (A).

Do not over fill the fuel tank, fill only to bottom (B) of the filler (A) to prevent spill out of the fuel from the tank cap.

Fuel Tank Capacity, 2.0 L (0.528 us.gal)

- Close the tank cap securely by turning it clockwise as far as it will go.

Engine Oil

Check the engine oil level daily before starting the engine otherwise shortage of the engine oil may cause serious damage to the engine such as seizure.

- Place the engine (equipment) on level surface. Clean area around the oil gauge before removing it.
- Remove the oil gauge (A) and wipe it with clean cloth.
- Pour the oil slowly to "FULL" mark on the oil gauge.
- Insert the oil gauge into the oil filler (B) WITHOUT SCREWING IT IN.

- Remove the oil gauge to check the oil level. Level should be between "ADD" and "FULL" marks. Do not overfill.
- Install and tighten the oil gauge.

Engine Oil Capacity, 0.65 L (0.69 us.qt)

CAUTION: The engine is shipped without engine oil.

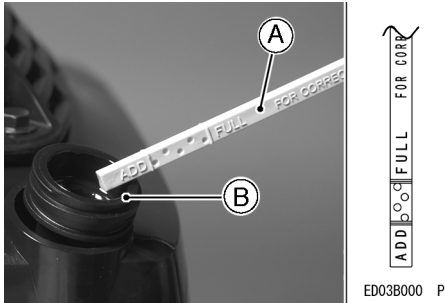

Figure 7

Starting

Band Pad System

Upon releasing the brake control lever on the equipment, the cutting blade and the engine will stop automatically.

Therefore, the brake control lever must be held against the handle while the engine is started and running.

Starting Engine

- Fully push the priming button (A) by thumb only once.

NOTE: When the engine is already warm or on hot days, do not push the priming button to prevent faulty starting engine caused by flooding carburetor.

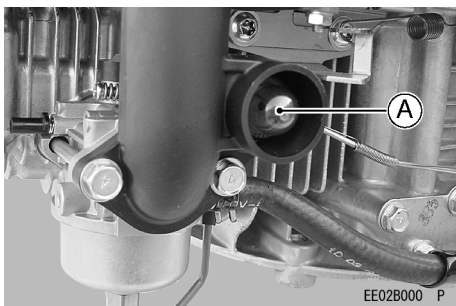

Figure 8

CAUTION:

- DO NOT** start the engine when the cutting blade is in contact with long, uncut grass, it may cause difficulties in starting and damage to the recoil starter.
- DO NOT** attempt to start the engine when the brake control lever on the equipment is released from your hands; this may cause

damage to the recoil starter or pad system of the engine.

- DO NOT** pull the recoil starter grip out of the end.
- DO NOT** let the recoil starter grip snap back itself. This may cause damage to the recoil starter assembly.
- Hold the brake control lever (A) on the equipment against the handle (B) on the equipment.
- Pull the recoil starter grip (C) slowly until you feel compression, then pull fast and steady.

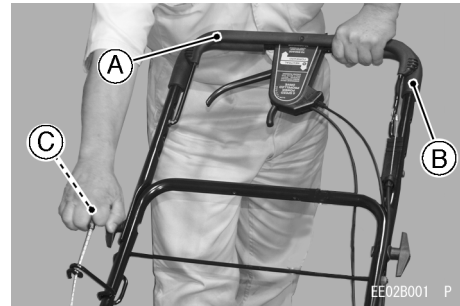

Figure 9

- A. Brake Control Lever
- B. Handle
- C. Recoil Starter Grip

Warming up

CAUTION: Allow engine to warm up before loading. This will allow oil to reach all the engine parts, and the piston clearance to reach design specification, before the engine is ready for loading.

- After engine starts, warm up the engine, run it for a few minutes.

Operating

- Anti-engine inclination
- This engine will operate continuously at angles up to 30° in any direction.
- Refer to the operating instructions of the equipment this engine powers.
- Because of equipment design or application, there may be more stringent restrictions regarding the angle of operation.

CAUTION: Do not operate this engine continuously at angles exceeding 30° in any direction. Engine damage could result from insufficient lubrication.

Stopping

Stopping Engine

Release the brake control lever (A) on the equipment from the handle (B) on the equipment to stop the engine and the cutting blade.

- A. Brake Control Lever
- B. Handle

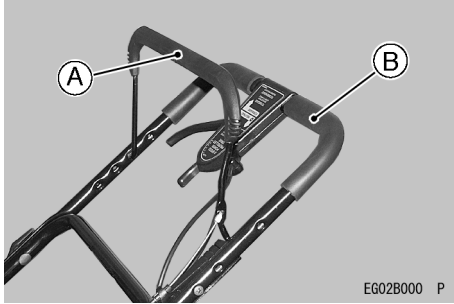

Figure 10

Adjustment

Engine Speed Adjustment

NOTE: Do not tamper with the governor setting or the carburetor setting to increase the engine speed. Each carburetor is adjusted at the factory with either a cap or stop plate installed on the mixture screw. Any adjustments must be performed by an authorized Kawasaki dealer.

MAINTENANCE

MAINTENANCE INTERVAL							
	DAILY	FIRST 8 HOURS	EVERY 25 HOURS	EVERY 50 HOURS	EVERY 100 HOURS	EVERY 200 HOURS	EVERY 300 HOURS
Check oil level and add engine oil	•						
Check for loose or lost nuts and screws	•						
Check for fuel and oil leakage	•						
Check for brake control lever function	•						
Check or clean recoil starter and air intake screen Tighten nuts and screws	•		•				
♦ Clean air cleaner foam element		•	•		•		
♦ Clean air cleaner paper element		•			•		
Change engine oil		•		•			
Clean and re-gap spark Plug					•		
♦ Replace air cleaner paper element							•
♦ Clean dust and dirt from cylinder and cylinder head fins							•
♦ Clean combustion chamber							•
♦ Check and adjust valve clearance							•
♦ Clean and lap valve seating surface							•

Periodic Maintenance Chart

NOTE: The service intervals indicated are to be used as a guide. Service should be performed more frequently as necessary by operating condition. Service more frequently under dusty conditions.

‡: Have an authorized Kawasaki dealer perform these services.

Oil Level Check

Check oil level daily and before each time of operation. Be sure oil level is maintained. See PREPARATION .

Oil Change

Change oil after first 8 hours of operation. Thereafter change oil every 50 hours.



WARNING: Hot engine oil can cause severe burns. Allow engine temperature to drop from hot to warm before draining and handling oil.

- Run the engine to warm oil.
- Be sure the engine (equipment) is level.
- Stop the engine.

- Remove the oil drain plug (A) on side of the engine or on bottom of the engine to drain oil into suitable container (B) while the engine is warm.

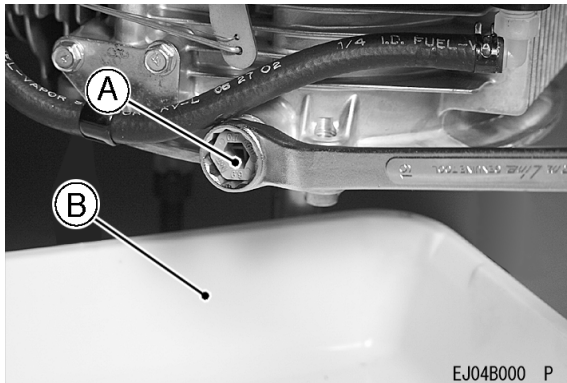

Figure 11

- A. Oil Drain Plug (On side of engine)
- B. Container

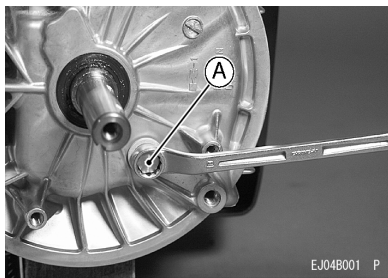

Figure 12

- A. Oil Drain Plug (On bottom of engine)
- Reinstall the oil drain plug.
 - Remove oil gauge and refill with new oil (See FUEL AND OIL RECOMMENDATIONS chapter).
 - Check the oil level (See PREPARATION chapter).



WARNING: Engine oil is toxic substance. Dispose of used oil properly. Contact your local authorities for approved disposal methods for possible recycling.

Cooling System Cleaning

Before each use, check that the recoil starter (A) is free from grass and debris and clean to prevent engine overheating.

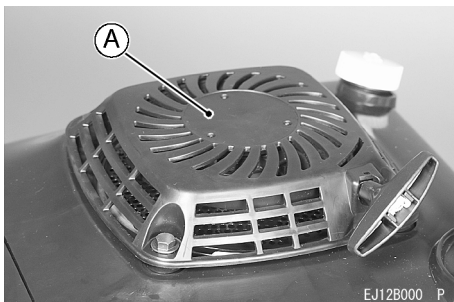

Figure 13

Air Cleaner Service

CAUTION: To prevent excessive engine wear, do not run the engine with the air cleaner



WARNING: Clean the elements in a well-ventilated area and take care that there are no sparks or flame anywhere near the working area, this includes any appliance with a pilot light. Do not use gasoline or low flash-point solvents to clean the element. A fire or explosion could result.

- Unfasten the air cleaner case (C) fastened with the air cleaner body (D) by sliding the two fasteners (A) toward the recoil starter (B). Then, with two hands, pulling the two latches (E) toward you and upward as shown, separate the air cleaner case from the air cleaner body.

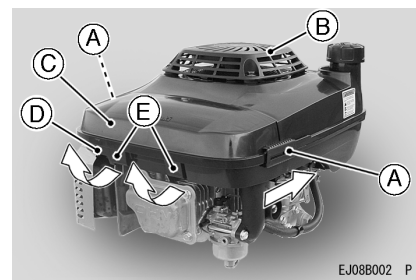

Figure 14

- A. Fasteners
- B. Recoil Starter
- C. Air Cleaner Case
- D. Air Cleaner body
- E. Latches

Remove the paper element (A) and the foam element (B) from the air cleaner body (C).

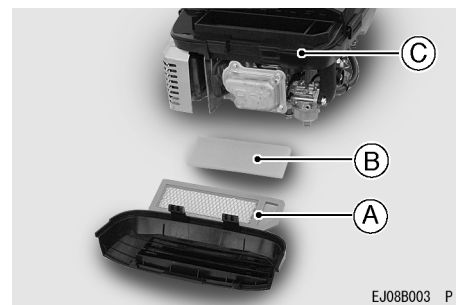

Figure 15

- A. Paper Element
- B. Foam Element
- C. Air Cleaner body

Foam Element

Clean the foam element every 25 hours.

Wash the element in detergent and water, and dry it thoroughly.

CAUTION: Do not oil foam element.

Paper Element

- Clean the paper element every 100 hours.
- Clean the element by tapping gently to remove dust. If very dirty, replace the element with a new one.
- Replace with a new paper-element yearly or 300 hours.

CAUTION: Do not wash paper-element. Do not use pressurized air to clean or dry paper element.

NOTE: Operating in a dusty condition may require more frequent maintenance than above.

- Reinstall the foam element and then the paper element on the air cleaner body.
- Reinstall the air cleaner case on the air cleaner body by first fitting the projection (B) on the edge of the air cleaner case into the slit (A) in the air cleaner body. Then, sliding the fasteners (C) toward the air cleaner case, securely fasten the air cleaner case with the air cleaner body.

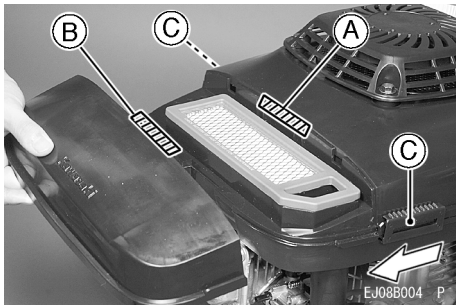

Figure 16

- A. Slit in the air cleaner body
- B. Projection on the air cleaner case
- C. Fasteners

CAUTION: After servicing the air cleaner, be sure all the removed parts are reinstalled properly in place. Failure to secure fastening of the air cleaner case with the air cleaner body may cause dirt or other foreign materials to enter the engine, while it is running, through the air cleaner, resulting in engine troubles or failures.



WARNING: Hot engine components can cause severe burns. Stop engine and allow it to cool before checking spark plug.

- Clean or replace the spark plug and reset gap (A) every 100 hours of operation.
- Disconnect the spark plug cap from spark plug and remove the spark plug.
- Clean the electrodes (B) by scraping or with a wire brush to remove carbon deposits.
- Inspect for cracked porcelain or other wear and damage. Replace the spark plug with a new one if necessary.

- Check the spark plug gap and reset it if necessary. The gap must be between 0.7 and 0.8 mm (0.028 and 0.032").

To change the gap, bend only the side-electrode, using a spark plug tool.

-Install and tighten the spark plug to 23 N-m (2.3kgf-m, 17fMb).

-Fit the spark plug cap on the spark plug securely.

-Pull up the spark plug cap lightly to make sure of the installation of the spark plug cap.

Recommended Spark Plug

NGK... BPR5ES

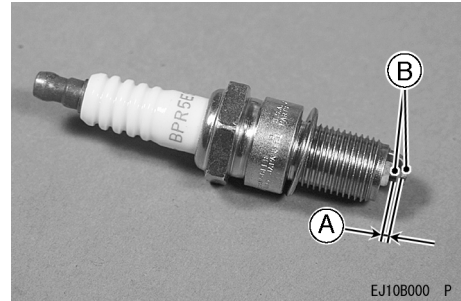

Figure 17

- A. Spark Plug Gap
- B. Electrodes

CAUTION: Be sure to use the same type of spark plug for change. Resistor spark plug is required in some areas by local law.

Storage

Engine to be stored over 30 days should be completely drained of fuel (gasoline) to prevent gum deposits forming on essential carburetor parts and the fuel system.



WARNING: Gasoline is extremely flammable and can be explosive under certain conditions. Drain gasoline before storing the equipment for extended periods. Drain gasoline in a well-ventilated area away from any source of flame or sparks, including any appliances with a pilot light. Store gasoline in an approved container in safe location.

- Remove the spark plug cap from spark plug to prevent accidental starting the engine.
- Empty the fuel from the fuel tank with a pump or siphon.
- Fit the plug cap on the spark plug securely
- Start and run the engine at idle speed to used up the fuel in the fuel system.



WARNING: Before maintaining engine, stop the engine and allow it cool.

- Remove the spark plug and pour approx. 1-2 mL (0.06-0.1 cu.in) of new engine oil through the plug hole (A), slowly pull the recoil starter grip several times and reinstall the spark plug.

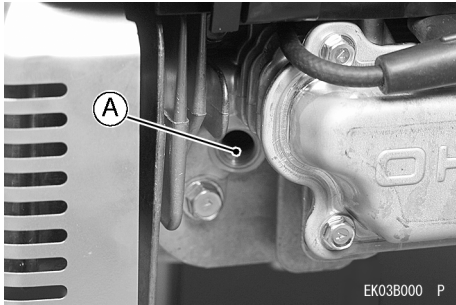
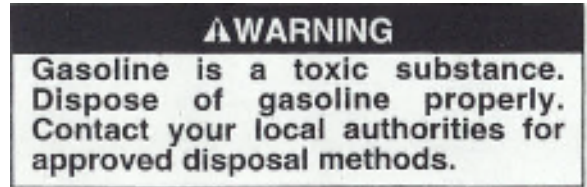

Figure 18

A. Spark Plug Hole

- Slowly pull the recoil starter grip until you feel compression and leave it there.
- Clean every part of the engine.
- After period of storage, change engine oil.
- (Refer to "Oil Change" section in "MAINTENANCE" section).



Troubleshooting Guide

Symptom		Probable Cause	Remedy
Engine won't start output is low	Insufficient compression	<ol style="list-style-type: none"> 1. Faulty piston, cylinder, piston ring, and head gasket 2. Faulty valves 3. Loose spark plug 4. Loose cylinder head bolts 	<ol style="list-style-type: none"> 1. Tighten properly 2. Tighten properly 3. Tighten properly 4. Tighten properly
	No fuel to combustion chamber	<ol style="list-style-type: none"> 1. No fuel in fuel tank 2. Blocked fuel tube 3. Blocked air vent in fuel tank cap 4. Faulty carburetor 	<ol style="list-style-type: none"> 1. Fill fuel tank 2. Clean 3. Clean 4. ‡
	Spark plug fouled by fuel	<ol style="list-style-type: none"> 1. Over-rich fuel/air mixture 2. Clogged air cleaner 3. Faulty carburetor 4. Incorrect grade/type of fuel 5. Water in fuel 	<ol style="list-style-type: none"> 1. Slowly pull the recoil starter grip with spark plug removed to discharge excess fuel. clean spark plug 2. Clean 3. ‡ 4. Change Gasoline 5. Change Gasoline
	No spark or weak spark	<ol style="list-style-type: none"> 1. Faulty spark plug 2. Faulty ignition coil 3. Faulty engine switch 	<ol style="list-style-type: none"> 1. Replace spark plug 2. ‡ 3. ‡
Low Output	Engine Overheats	<ol style="list-style-type: none"> 1. Clogged air cleaner 2. Recoil Starter or cooling air path clogged with dirt 3. Insufficient engine oil 4. carbon built-up in combustion chamber 5. Poor ventilation around engine 	<ol style="list-style-type: none"> 1. Clean 2. Clean 3. Replenish or change oil 4. ‡ 5. Select a better location
	1. Engine speed won't increase	<ol style="list-style-type: none"> 1. Faulty Governor 	<ol style="list-style-type: none"> ‡

If the engine malfunctions, carefully examine the symptoms and the operating conditions, and use the table above as a guide to troubleshooting. ‡ Have an authorized Kawasaki dealer perform these service

Environmental Protection

To protect our environment, properly discard used batteries, engine oil, gasoline, coolant, or other components that you might dispose of in the future.

Consult your authorized Kawasaki dealer or local environmental waste agency for their proper disposal procedure.

Specifications

Type of Engine	Air-cooled, 4-stroke OHV, single cylinder, gasoline Engine
• Bore X Stroke	• 65 x 54mm (2.6 x 2.1 in.)
• Displacement	• 179mL (109. cu.in.)
• Ignition system	• Solid-state ignition
• Starting system	• Recoil starter
• Dry weight	• 13.5kg (29.lb)

Specifications subject to change without notice

**KAWASAKI LIMITED WARRANTY
CALIFORNIA AND FEDERAL
EMISSION CONTROL SYSTEMS
SMALL OFF-ROAD ENGINES**

The California Air Resources Board, the Environmental Protection Agency (EPA), and Kawasaki Motors Corp., U.S.A. (hereinafter "Kawasaki") are pleased to explain the Emission Control Systems Warranty on your Kawasaki small off-road engine. In California and other states, new small off-road engines must be designed, built and equipped to meet stringent anti-smog standards. Kawasaki must warrant the emission control system on your small off-road engine for the period of time listed below provided there has been no abuse, neglect or improper maintenance of your small off-road engine. Your emission control system may include parts such as the carburetor or fuel-injection system, the ignition system, and catalytic converter. Also included may be hoses, belts, connectors and other emission related assemblies. Where a warrantable condition exists, Kawasaki will repair your small off-road engine at no cost to you including diagnosis (if the diagnostic work is Performed at a Kawasaki small off-road engine dealer), parts and labor.

OWNERS WARRANTY RESPONSIBILITIES. The following obligations must be fulfilled by the owner to maintain the validity of the Kawasaki California / EPA Emissions Systems Warranty:

- (a) As the small off-road engine owner, you are responsible for the performance of the required maintenance listed in your owner's manual. Kawasaki recommends that you retain all receipts covering maintenance on your small off-road engine, but Kawasaki cannot deny warranty solely for the lack of receipts or for your failure to ensure the performance of all scheduled maintenance.
- (b) You are responsible for presenting your small off-road engine to an authorized Kawasaki small off-road engine Dealer as soon as a problem exists. The warranty repairs should be completed in a reasonable amount of time, not to exceed 30 days.
- (c) AS the small off-road engine owner, you should also be aware that Kawasaki may deny you warranty coverage if your small off-road engine or a part has failed due to abuse, neglect, improper maintenance or unapproved modifications.
- (d) If you have any questions regarding your warranty rights and responsibilities, you should contact Kawasaki Motors Corp., U.S.A., Consumer Services Department, 5080 36th Street, S.E., Grand Rapids, MI 49512, 616/949-6500..

1. COVERAGE. Kawasaki warrants to the initial owner and each subsequent purchaser that the small off-road engine is free from defects in materials and workmanship which cause a failure of a warranted part for a period of two years. Kawasaki is liable for damages to other engine components caused by the failure of a warranted part still under warranty. The 1995 and later small off-road engines are warranted for two years in California. In all other states, 1997 and later model year small off-road engines are warranted for two years. If any emission-related part on your engine is defective, the part will be repaired or replaced by Kawasaki. This warranty time period shall begin on the date the small off-road engine is delivered to the initial purchaser, or on the date the small off-road engine is first placed in service.

Warranty defects shall be remedied during customary business hours at any authorized Kawasaki small off-road engine dealer located within the United States of America. Any manufacturer-approved replacement part may be used in the performance of any warranty maintenance or repairs on emission-related parts, and must be provided without charge to the owner if the part is still under warranty. Any part or parts replaced under this warranty shall become the property of Kawasaki.

The emission related warranted parts are specifically defined by the California Air Resources Board's Emission Warranty Parts List. (EPA's regulations do not include a parts list, but EPA considers emission-related parts to include all parts listed here.) These warranted parts are: carburetor and internal parts, spark advance/retard system, cold start enrichment system, magneto or electronic ignition system, catalytic converter, intake manifold, exhaust manifold, air cleaner element, and spark plugs if failure occurs prior to the first required scheduled replacement, hoses, clamps, fittings, gaskets, sealing devices, mounting hardware and tubing used directly in these parts.

Since emission related parts may vary slightly from model to model, certain models may not contain all of these parts and certain models may contain functionally equivalent parts.

2. LIMITATIONS. This Emission Control Systems Warranty shall not cover any of the following:

- (a) Repair or replacement required as a result of (i) misuse or neglect, (ii) lack of required maintenance, (iii) repairs improperly performed or replacements improperly installed, (iv) use of replacement parts or accessories not conforming to Kawasaki specifications which adversely affect performance and/or durability, (v) alterations or modifications not recommended or approved in writing by Kawasaki.
- (b) Replacement of parts and other services and adjustments necessary for required maintenance at and after the first scheduled replacement point.

LIMITED LIABILITY.

(a) The liability of Kawasaki under this Emission Control Systems Warranty is limited solely to the remedying of defects in materials or workmanship by any authorized Kawasaki small off-road engine dealer at its place of business during customary business hours. This warranty does not cover inconvenience or loss of use of the small off-road engine or transportation of the small off-road engine to or from the Kawasaki Dealer. KAWASAKI SHALL NOT BE LIABLE FOR ANY OTHER EXPENSE, LOSS OR DAMAGE, WHETHER DIRECT, INCIDENTAL, CONSEQUENTIAL (EXCEPTION LISTED UNDER COVERAGE) OR EXEMPLARY ARISING IN CONNECTION WITH THE SALE OR USE OF OR INABILITY TO USE THE KAWASAKI SMALL OFF-ROAD ENGINE FOR ANY PURPOSE.

(b) NO EXPRESS EMISSION CONTROL SYSTEMS WARRANTY IS GIVEN BY KAWASAKI WITH RESPECT TO THE KAWASAKI SMALL OFF-ROAD ENGINE EXCEPT AS SPECIFICALLY SET FORTH HEREIN. ANY EMISSION CONTROL SYSTEMS WARRANTY IMPLIED BY LAW, INCLUDING ANY WARRANTY OF MERCHANTABILITY OR FITNESS FOR A PARTICULAR PURPOSE, IS EXPRESSLY LIMITED TO THE EMISSION CONTROL SYSTEMS WARRANTY TERMS SET FORTH HEREIN. THE FOREGOING STATEMENTS OF WARRANTY ARE EXCLUSIVE AND IN LIEU OF ALL OTHER REMEDIES.

(c) No dealer is authorized to modify this Kawasaki Limited Emission Control Systems Warranty.

(d) Kawasaki is not liable for parts which are not genuine Kawasaki parts except when genuine Kawasaki parts cause damage to non-Kawasaki parts.

LEGAL RIGHTS. THIS WARRANTY GIVES YOU SPECIFIC LEGAL RIGHTS, AND YOU MAY ALSO HAVE OTHER RIGHTS.

THIS WARRANTY IS IN ADDITION TO THE KAWASAKI LIMITED SMALL OFF-ROAD ENGINE WARRANTY.

MANUFACTURER'S LIMITED WARRANTY FOR:



The limited warranty set forth below is given by Cub Cadet LLC with respect to new merchandise purchased and used in the United States, its possessions and territories.

Cub Cadet LLC warrants this product against defects for a period of two (2) years commencing on the date of original purchase and will, at its option, repair or replace, free of charge, any part found to be defective in materials or workmanship. This limited warranty shall only apply if this product has been operated and maintained in accordance with the Operator's Manual furnished with the product, and has not been subject to misuse, abuse, commercial use, neglect, accident, improper maintenance, alteration, vandalism, theft, fire, water, or damage because of other peril or natural disaster. Damage resulting from the installation or use of any accessory or attachment not approved by Cub Cadet LLC for use with the product(s) covered by this manual will void your warranty as to any resulting damage.

Normal wear parts or components thereof are subject to separate terms as follows: All normal wear parts or component failures will be covered on the product for a period of 90 days regardless of cause. After 90 days, but within the two year period, normal wear part failures will be covered ONLY IF caused by defects in materials or workmanship of OTHER component parts. Normal wear parts and components include, but are not limited to: batteries, belts, blades, blade adapters, grass bags, rider deck wheels, seats, snow thrower skid shoes, shave plates, auger spiral rubber, and tires.

HOW TO OBTAIN SERVICE: Warranty service is available, WITH PROOF OF PURCHASE, through your local authorized service dealer. To locate the dealer in your area, check your Yellow Pages, or contact Cub Cadet LLC at P.O. Box 361131, Cleveland, Ohio 44136-0019, or call 1-877-282-8684, or log on to our Web site at www.cubcadet.com.

This limited warranty does not provide coverage in the following cases:

- a. The engine or component parts thereof. These items carry a separate manufacturer's warranty. Refer to applicable manufacturer's warranty for terms and conditions.
- b. Log splitter pumps, valves, and cylinders have a separate one year warranty.
- c. Routine maintenance items such as lubricants, filters, blade sharpening, tune-ups, brake adjustments, clutch adjustments, deck adjustments, and normal deterioration of the exterior finish due to use or exposure.

- d. Cub Cadet LLC does not extend any warranty for products sold or exported outside of the United States, its possessions and territories, except those sold through Cub Cadet LLC's authorized channels of export distribution.
- e. Parts that are not genuine Cub Cadet parts are not covered by this warranty.
- f. Service completed by someone other than an authorized service dealer is not covered by this warranty.
- g. Transportation charges and service calls are not covered.

No implied warranty, including any implied warranty of merchantability of fitness for a particular purpose, applies after the applicable period of express written warranty above as to the parts as identified. No other express warranty, whether written or oral, except as mentioned above, given by any person or entity, including a dealer or retailer, with respect to any product, shall bind Cub Cadet LLC. During the period of the warranty, the exclusive remedy is repair or replacement of the product as set forth above.

The provisions as set forth in this warranty provide the sole and exclusive remedy arising from the sale. Cub Cadet LLC shall not be liable for incidental or consequential loss or damage including, without limitation, expenses incurred for substitute or replacement lawn care services or for rental expenses to temporarily replace a warranted product.

Some states do not allow the exclusion or limitation of incidental or consequential damages, or limitations on how long an implied warranty lasts, so the above exclusions or limitations may not apply to you.

In no event shall recovery of any kind be greater than the amount of the purchase price of the product sold. **Alteration of safety features of the product shall void this warranty.** You assume the risk and liability for loss, damage, or injury to you and your property and/or to others and their property arising out of the misuse or inability to use the product.

This limited warranty shall not extend to anyone other than the original purchaser or to the person for whom it was purchased as a gift.

HOW STATE LAW RELATES TO THIS WARRANTY: This limited warranty gives you specific legal rights, and you may also have other rights which vary from state to state.

Cub Cadet LLC, P.O. BOX 361131 CLEVELAND, OHIO 44136-0019; Phone: 1-877-282-8684

Free Manuals Download Website

<http://myh66.com>

<http://usermanuals.us>

<http://www.somanuals.com>

<http://www.4manuals.cc>

<http://www.manual-lib.com>

<http://www.404manual.com>

<http://www.luxmanual.com>

<http://aubethermostatmanual.com>

Golf course search by state

<http://golfingnear.com>

Email search by domain

<http://emailbydomain.com>

Auto manuals search

<http://auto.somanuals.com>

TV manuals search

<http://tv.somanuals.com>