

# OPERATOR'S MANUAL

# *Cub Cadet*

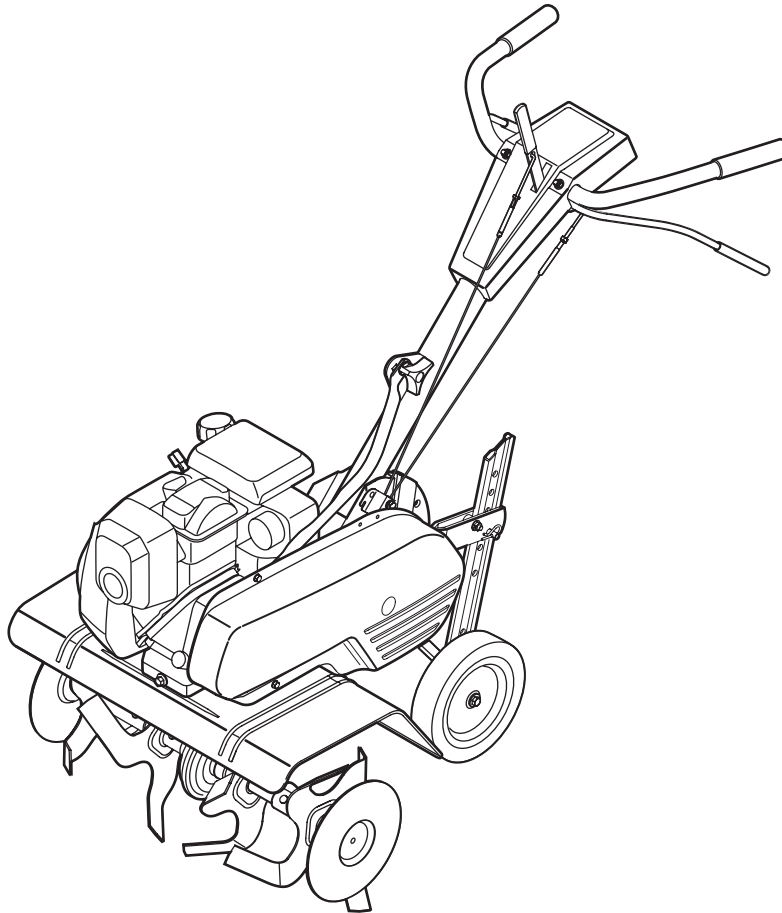

## Front Tine Tiller — Model Series 390

### IMPORTANT

#### READ SAFETY RULES AND INSTRUCTIONS CAREFULLY BEFORE OPERATION

**Warning:** This unit is equipped with an internal combustion engine and should not be used on or near any unimproved forest-covered, brush-covered or grass-covered land unless the engine's exhaust system is equipped with a spark arrester meeting applicable local or state laws (if any). If a spark arrester is used, it should be maintained in effective working order by the operator. In the State of California the above is required by law (Section 4442 of the California Public Resources Code). Other states may have similar laws. Federal laws apply on federal lands. A spark arrester for the muffler is available through your nearest engine authorized service dealer or contact the service department, P.O. Box 361131 Cleveland, Ohio 44136-0019.

This Operator's Manual is an important part of your new tiller. It will help you assemble, prepare and maintain the unit for best performance. Please read and understand what it says.

## Table of Contents

Safety Labels .....	3	Maintaining Your Tiller .....	12
Safe Operation Practices .....	4	Trouble Shooting .....	15
Assembly .....	6	Parts List .....	16
Operating Your Tiller .....	8	Warranty .....	Back Cover

## Finding and Recording Model Number

BEFORE YOU BEGIN ASSEMBLING YOUR NEW EQUIPMENT, please locate the model plate on the equipment and copy the information to the sample model plate provided to the right. You can locate the model plate by looking at the rear of the tine shield. This information is important for use when visiting the manufacturer's web site, obtaining assistance from the Customer Support Department, or when communicating with an authorized service dealer.

Model Number

Serial Number



MTD LLC  
P.O. BOX 361131  
CLEVELAND, OH 44136  
330-220-4683  
800-800-7310

## Customer Support

Please do **NOT** return the unit to the retailer from which it was purchased, without first contacting Customer Support.

If you have difficulty assembling this product or have any questions regarding the controls, operation, or maintenance of this unit, you can seek help from the experts. Choose from the options below:

- Visit **mtdproducts.com**.
- Call a **Customer Support Representative** at 1-800-800-7310.
- The **engine manufacturer** is responsible for all engine-related issues with regards to performance, power-rating, specifications, warranty and service. Please refer to the engine manufacturer's Owner's/Operator's Manual, packed separately with your unit, for more information.

# Safety Labels Found On Your Tiller

## **WARNING**

### TO AVOID SERIOUS INJURY

- READ THE OPERATOR'S MANUAL.
- KNOW LOCATION AND FUNCTIONS OF ALL CONTROLS.
- KEEP ALL SAFETY DEVICES AND SHIELDS IN PLACE AND WORKING.
- NEVER ALLOW CHILDREN OR UNINSTRUCTED ADULTS TO OPERATE TILLER.
- SHUT OFF ENGINE BEFORE UNCLOGGING TINES OR MAKING REPAIRS.
- KEEP BYSTANDERS AWAY FROM MACHINE.
- KEEP AWAY FROM ROTATING PARTS.
- USE EXTREME CAUTION WHEN REVERSING OR PULLING THE MACHINE TOWARDS YOU.

## **WARNING**

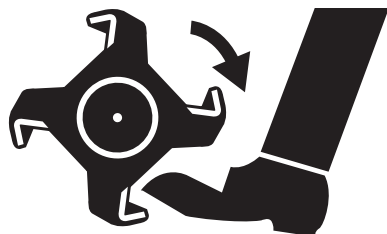

KEEP AWAY FROM ROTATING TINES. ROTATING TINES WILL CAUSE INJURY.

S30159

# 1

## Safety Labels



### **WARNING**

DO NOT remove safety (or any) labels from tiller for any reason.

# 2

## Safe Operation Practices



### WARNING

This symbol points out important safety instructions which, if not followed, could endanger the personal safety and/or property of yourself and others. Read and follow all instructions in this manual before attempting to operate this machine. Failure to comply with these instructions may result in personal injury. When you see this symbol, HEED ITS WARNING!



**WARNING:** Engine Exhaust, some of its constituents, and certain vehicle components contain or emit chemicals known to State of California to cause cancer and birth defects or other reproductive harm.

**DANGER:** This machine was built to be operated according to the rules for safe operation in this manual. As with any type of power equipment, carelessness or error on the part of the operator can result in serious injury. This machine is capable of amputating hands and feet and throwing objects. Failure to observe the following safety instructions could result in serious injury or death.

#### Training

- Read, understand, and follow all instructions on the machine and in the manual(s) before attempting to assemble and operate. Keep this manual in a safe place for future and regular reference and for ordering replacement parts.
- Be familiar with all controls and their proper operation. Know how to stop the machine.
- Never allow children under 14 years old to operate this machine. Children 14 years old and over should read and understand the operation instructions and safety rules in this manual and should be trained and supervised by a parent.
- Never allow adults to operate this machine without proper instruction.
- Keep bystanders, helpers, pets, and children at least 75 feet from the machine while it is in operation. Stop machine if anyone enters the area.

#### Preparation

- Thoroughly inspect the area where the equipment is to be used. Remove all stones, sticks, wire, and other foreign objects which could be tripped over and cause personal injury.
- Wear sturdy, rough-soled work shoes and close fitting slacks and shirt. Loose fitting clothes or jewelry can be caught in movable parts. Never operate this machine in bare feet or sandals.
- Disengage clutch levers and shift (if provided) into neutral ("N") before starting the engine.
- Never leave this machine unattended with the engine running.
- Never attempt to make any adjustments while engine is running, except where specifically recommended in the operator's manual.
- To avoid personal injury or property damage use extreme care in handling gasoline. Gasoline is extremely flammable and the vapors are explosive. Serious personal injury can occur when gasoline is spilled on yourself or your clothes which can ignite. Wash your skin and change clothes immediately.
- Use only an approved gasoline container.
- Extinguish all cigarettes, cigars, pipes and other sources of ignition.
- Never fuel machine indoors.

- Never remove gas cap or add fuel while the engine is hot or running.
- Allow engine to cool at least two minutes before refueling
- Never over fill fuel tank. Fill tank to no more than 1/2 inch below bottom of filler neck to provide space for fuel expansion.
- Replace gasoline cap and tighten securely.
- If gasoline is spilled, wipe it off the engine and equipment. Move machine to another area. Wait five minutes before starting the engine.
- Never store the machine or fuel container inside near an open flame, spark or pilot light (e.g. furnace, water or space heater, clothes dryer, etc.).
- Allow machine to cool five minutes before storing.

#### Operation

- Do not put hands or feet near rotating parts. Contact with the rotating parts can amputate hands and feet.
- Do not operate machine while under the influence of alcohol or drugs.
- Never operate this machine without good visibility or light. Always be sure of your footing and keep a firm hold on the handles.
- Keep bystanders, helpers, pets, and children at least 75 feet from the machine while it is in operation. Stop the machine if anyone enters the area.
- Be careful when tilling in hard ground. The tines may catch in the ground and propel the tiller forward. If this occurs, let go of the handle bars and do not restrain the machine.
- Exercise extreme caution when operating on or crossing gravel surfaces. Stay alert for hidden hazards or traffic.
- Never operate the machine at high transport speeds on hard or slippery surfaces.
- Exercise caution to avoid slipping or falling.
- Look down and behind and use care when in reverse or pulling machine towards you.
- Start the engine according to the instructions found in this manual and keep feet well away from the tines at all times.

- After striking a foreign object, stop the engine, disconnect the spark plug wire and ground against the engine. Thoroughly inspect the machine for any damage. Repair the damage before starting and operating.
- Disengage all clutch levers (if fitted) and stop engine before you leave the operating position (behind the handles). Wait until the tines come to a complete stop before unclogging the tines, making any adjustments, or inspections.
- Never run an engine indoors or in a poorly ventilated area. Engine exhaust contains carbon monoxide, an odorless and deadly gas.
- Muffler and engine become hot and can cause a burn. Do not touch.
- Use caution when tilling near fences, buildings and underground utilities. Rotating tines can cause property damage or personal injury.
- Do not overload machine capacity by attempting to till soil too deep at too fast of a rate.
- If the machine should start making an unusual noise or vibration, stop the engine, disconnect the spark plug wire and ground it against the engine. Inspect thoroughly for damage. Repair any damage before starting and operating.
- Keep all shields, guards, and safety devices in place and operating properly.
- Never pick up or carry machine while the engine is running.
- Use only attachments and accessories approved by the manufacturer. Failure to do so can result in personal injury.
- If situations occur which are not covered in this manual, use care and good judgment. Contact your dealer or call the customer service number found on page two.

## Maintenance & Storage

- Never tamper with safety devices. Check their proper operation regularly.
- Check bolts and screws for proper tightness at frequent intervals to keep the machine in safe working condition. Also, visually inspect machine for any damage.
- Before cleaning, repairing, or inspecting, stop the engine and make certain the tines and all moving parts have stopped. Disconnect the spark plug wire and ground it against the engine to prevent unintended starting.
- Do not change the engine governor settings or over-speed the engine. The governor controls the maximum safe operating speed of the engine.
- Maintain or replace safety and instruction labels, as necessary.
- Follow this manual for safe loading, unloading, transporting, and storage of this machine.
- Never store the machine or fuel container inside where there is an open flame, spark or pilot light such as a water heater, furnace, clothes dryer, etc.
- Always refer to the operator's manual for proper instructions on off-season storage.
- If the fuel tank has to be drained, do this outdoors.
- Observe proper disposal laws and regulations for gas, oil, etc. to protect the environment.

## Your Responsibility

- Restrict the use of this power machine to persons who read, understand, and follow the warnings and instructions in this manual and on the machine.
- The safety labels on the tiller are shown in the "Safety Labels" section. To ensure safe operation of the tiller, follow the instructions on all labels closely.

# 2

## Safe Operation Practices



### WARNING

This symbol points out important safety instructions which, if not followed, could endanger the personal safety and/or property of yourself and others. Read and follow all instructions in this manual before attempting to operate this machine. Failure to comply with these instructions may result in personal injury. When you see this symbol, HEED ITS WARNING!

# 3

## Assembly



**NOTE:** Stand behind the tiller as if you were going to operate it. Your right hand corresponds to right side of tiller; your left hand corresponds to left side of tiller.

### IMPORTANT

This unit is shipped without gasoline or oil in the engine. Fill up gasoline and oil as instructed in the accompanying engine manual **BEFORE** operating your tiller.

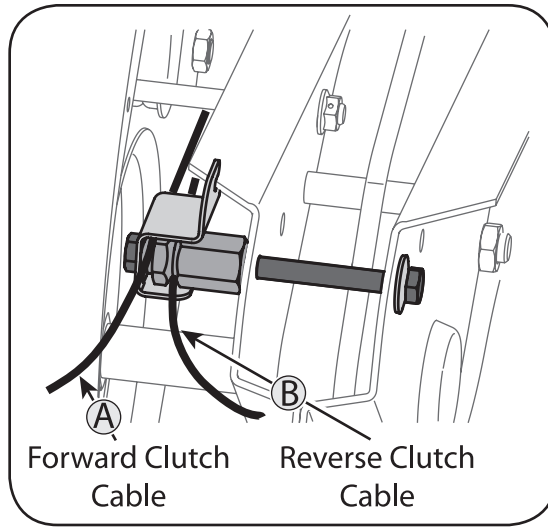

Figure 3-1: Identify Cables.

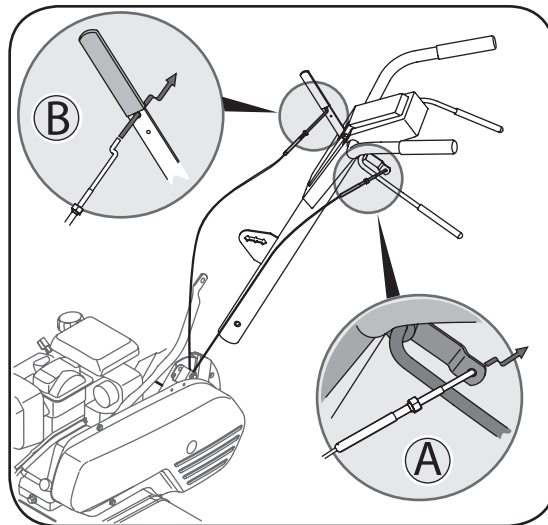

Figure 3-2: Insert cables into levers.

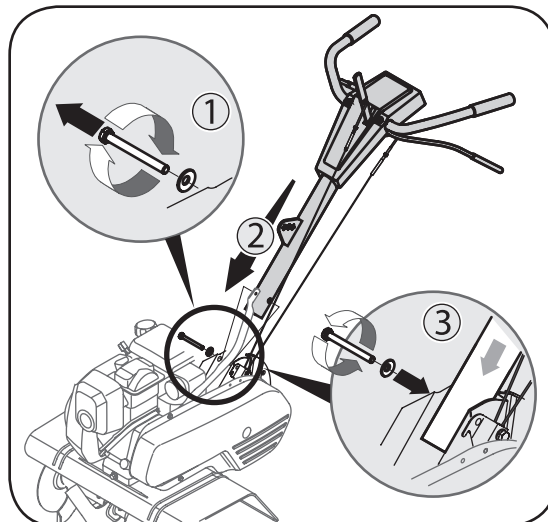

Figure 3-3: Insert handle into frame.

## Tiller Setup

References to right and left side of tiller are determined from behind the unit in the operating position.

### Handle Attachment

1. Identify forward clutch cable (A) and reverse clutch cables (B). Figure 3-1.

Be sure not to kink cables while attaching.

2. Hook the "Z" end of the forward clutch cable (A) into the forward tine engagement lever Figure 3-2.
3. Hook the "Z" end of the reverse clutch cable (B) into the reverse tine engagement lever Figure 3-2.

4. Remove the hex bolt and cupped washer from the right side of the frame. Hold the cable guide bracket on the left side of frame as it will fall when the bolt is removed. Figure 3-3 Step 1.
5. Insert handle into tiller frame as shown. See Figure 3-3 Step 2.
6. Insert bolt through the cupped washer, frame, handle and into the cable guide bracket (note the notch in the cable guide bracket goes over the flange on the frame.) See Figure 3-3 Step 3. Tighten the bolt securely after securing handle brace as seen in Figure 3-4.

7. Locate the carriage bolt, bell washer and hand knob packed with your unit.
8. Insert the carriage bolt through the welded bracket on the handle, bell washer, handle brace and into the hand knob. See Figure 3-4.
9. Select one of the three handle height positions (three notches in welded handle bracket) and tighten the hand knob to secure the handle in the desired position. Figure 3-4. Return to lower handle and tighten the hex bolt securely

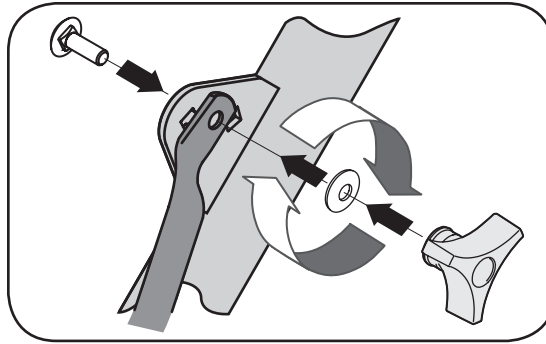

Figure 3-4: Remove hardware from lower handle.

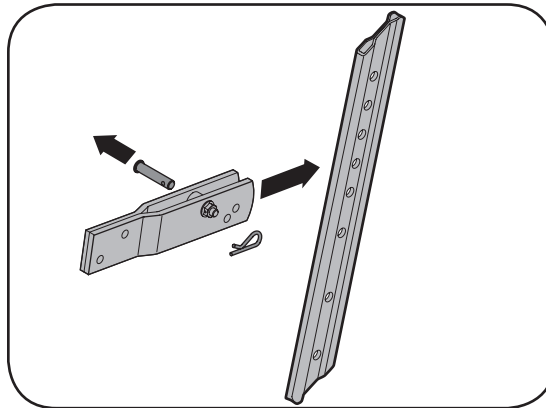

Figure 3-5: Disassemble depth gage if necessary.

### Depth Gage Attachment

1. Disassemble the depth gage assembly as seen in Figure 3-5. Retain the pin and clip for later reassembly.

2. Remove the two screws from the rear of the tiller frame as shown in Figure 3-6.
3. Insert the depth gage bracket into the frame and reinstall the two screws removed earlier. Tighten the hex bolts securely. See Figure 3-6.

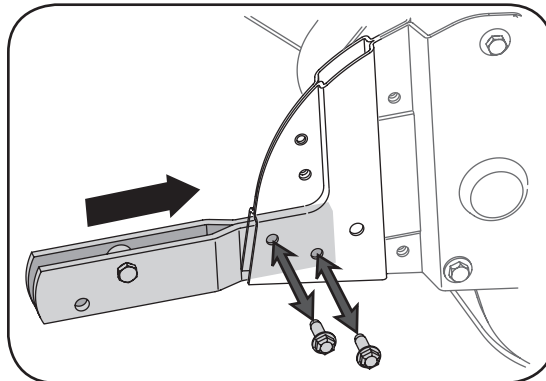

Figure 3-6: Insert depth gage bracket into frame.

4. Insert the depth stake into the depth gage bracket assembly as seen in Figure 3-7. Secure the pin with the clip removed earlier. The depth stake can be placed at various positions. For setup purposes it is suggested that the depth stake be assembled with the stake just above or level with the ground surface. For further instructions on the Depth Stake refer to adjustments section of this manual.

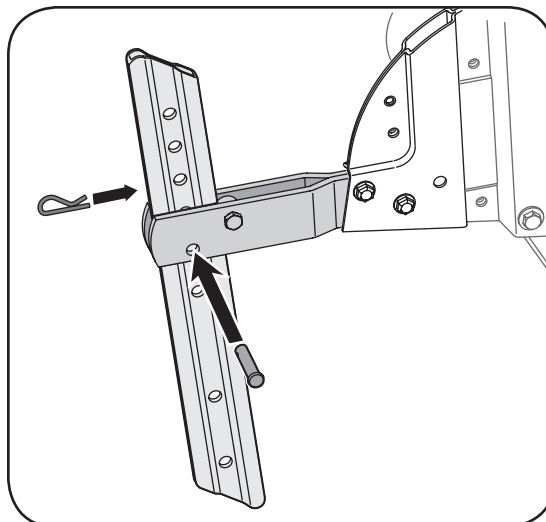

Figure 3-7: Reassemble depth stake.

# 3

## Assembly



**NOTE:** Stand behind the tiller as if you were going to operate it. Your right hand corresponds to right side of tiller; your left hand corresponds to left side of tiller.

### IMPORTANT

This unit is shipped without gasoline or oil in the engine. Fill up gasoline and oil as instructed in the accompanying engine manual **BEFORE** operating your tiller.

# 4

## Operating Your Tiller



### WARNING

The tine clutch control is a safety device. Never attempt to bypass its operation.

Use extreme care when handling gasoline. Gasoline is extremely flammable and the vapors are explosive. Never fuel tiller indoors or while engine is hot or running. Extinguish cigarettes, cigars, pipes, and other sources of ignition.

Keep hands and feet away from the tines. Refer to warning label on the unit.

## Your Tiller

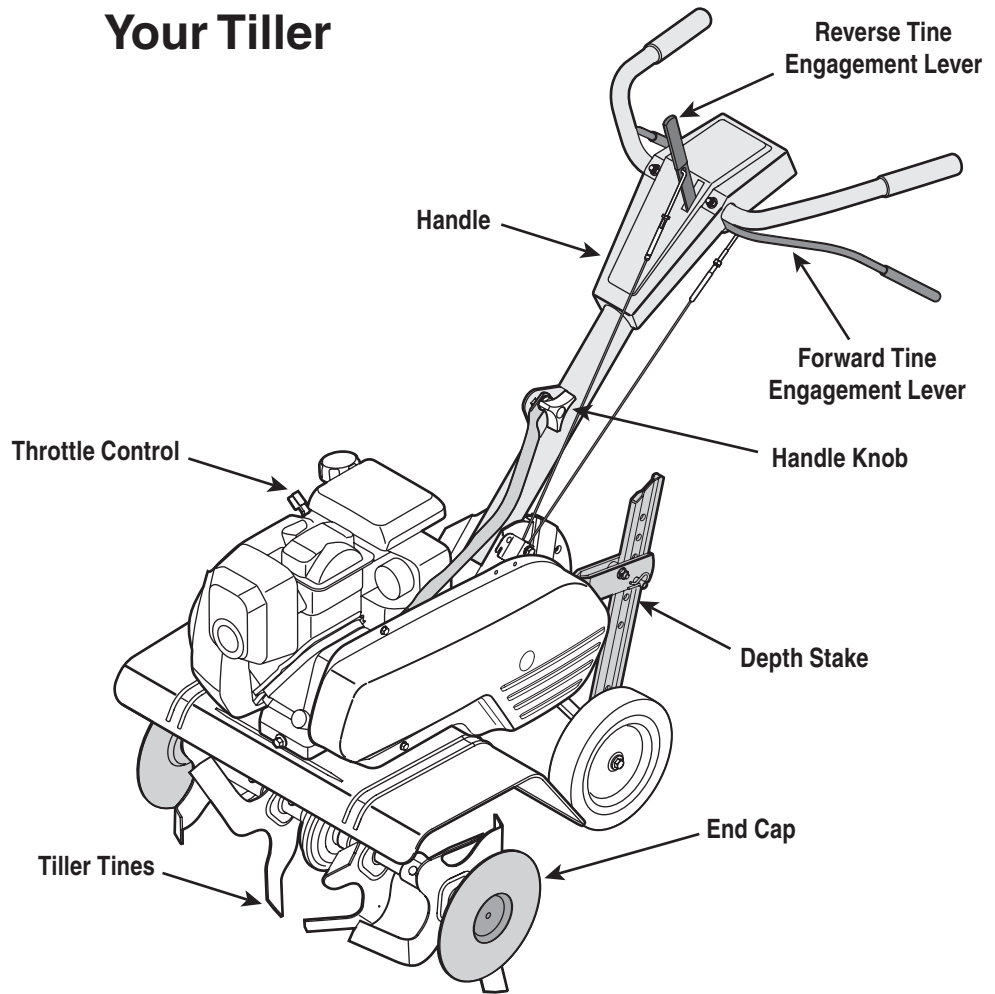

Figure 4-1: The major parts of the tiller



**WARNING:** Read, understand, and follow all instructions and warnings posted on the machine and in this manual before operating.

### Forward Tine Engagement Lever

The forward tine control lever is located beneath the upper section of the handle. Squeezing the lever against the handle engages the tine drive. Release the lever to stop the tines from turning.

### Reverse Tine Engagement Lever

The reverse tine control lever is located on top of the upper section of the handle. Pulling the lever toward operator engages the tines in reverse. Release the lever to stop the tines from turning in reverse.

**Note:** Never engage both the forward and reverse tine drives at the same time. Engaging both forward and reverse tine drives at the same time could damage the belt drives and cause the engine to stall.

### Depth Stake

The depth stake controls the tilling depth. Refer to Operating Your Tiller later in this section for further instructions on its use.

### Tines and End Caps

Tilling tines and end caps are used to cultivate, furrow and prepare your garden for seeding. End caps are used to avoid tilled soil from overflowing onto unwanted areas.

### Handle Knob

The handle height may be adjusted. Loosen the knob to change the position. Tighten hardware when complete.

### Engine Controls

**NOTE:** Refer to engine manual for additional information and functions of the engine controls.

### Throttle Control

The throttle controls engine's speed. Use maximum engine speed when tilling. Stop the engine when transporting the tiller.

### Choke Lever

Choke lever is located next to the throttle lever. It is used to enrich the fuel mixture when starting a cold engine.

### Recoil Starter

The recoil starter is located on the right side of the engine and is used to manually start the engine.



# Operating Your Tiller

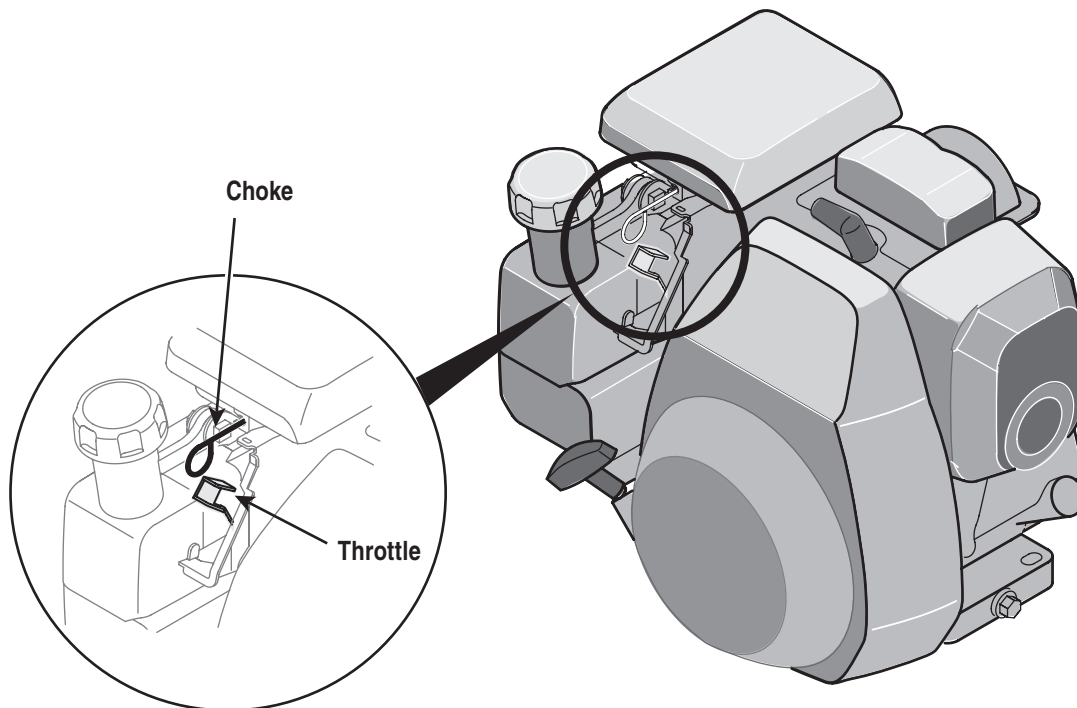

Figure 4-2: Engine choke and throttle controls



**WARNING:** Read, understand, and follow all instructions and warnings posted on the machine and in this manual before operating.

## Before Starting

### Gas And Oil Fill-Up

Service the engine with gasoline and oil as instructed in the separate engine manual packed with your tiller. *Read instructions carefully.*



**WARNING:** Use extreme care when handling gasoline. Gasoline is extremely flammable and the vapors are explosive. Never fuel machine indoors or while the engine is hot or running.

## Starting Engine



**WARNING:** Be sure no one is standing in front of the tiller while the engine is running or being started.

Refer to the engine manual for instructions.

1. Attach spark plug wire to spark plug. Make sure the metal cap on the end of the spark plug is fastened securely over the metal tip on the spark plug.
2. Make sure that the tine clutch control is disengaged.

3. Move throttle control 1/3 of the way toward the FAST position.
4. Move/pull out choke lever to CHOKE position when starting **cold** engine.
5. Pull rope out slowly until engine reaches the beginning of its compression cycle (rope will pull slightly harder at this point).
6. Pull rope with a rapid, continuous, full arm stroke. Keep a firm grip on handle. Let rope rewind slowly. Do not let recoil starter snap back against engine. Repeat until engine starts.
7. Move/push in choke lever once engine warms up enough to run smoothly.
8. Move throttle to FAST position for tilling.

## Stopping Engine

Move throttle control lever to STOP or OFF position. Refer to the engine manual for instructions on stopping the engine.

# 4

## Operating Your Tiller



### WARNING

Be sure no one other than the operator is standing near the tiller while starting engine or operating the unit. Never run engine indoors or in enclosed, poorly ventilated areas. Engine exhaust contains carbon monoxide, an odorless and deadly gas. Keep hands, feet, hair and loose clothing away from any moving parts on engine and tiller.



Refer to the engine manual for detailed engine instructions.

# 4

## Operating Your Tiller



### WARNING

Be sure no one other than the operator is standing near the tiller while starting engine or operating the unit. Never run engine indoors or in enclosed, poorly ventilated areas. Engine exhaust contains carbon monoxide, an odorless and deadly gas. Keep hands, feet, hair and loose clothing away from any moving parts on engine and tiller.



Refer to the engine manual for detailed instructions pertaining to the engine controls.

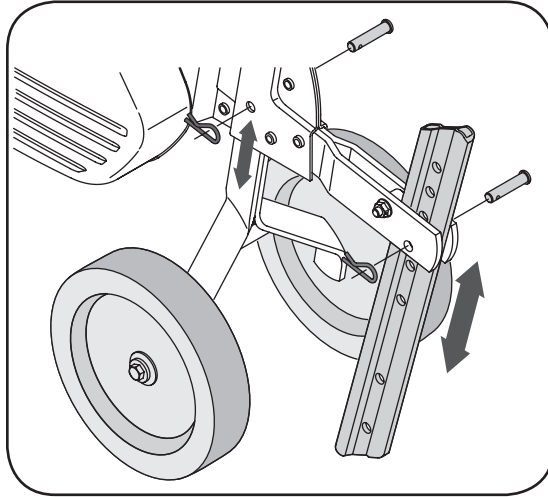

Figure 4-3: Wheel and depth stake positioning.

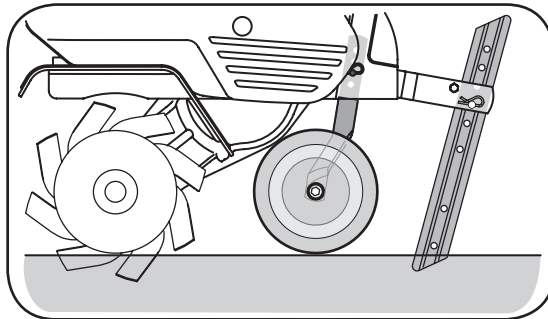

Figure 4-4: Wheel and Yoke forward for shallow tilling.

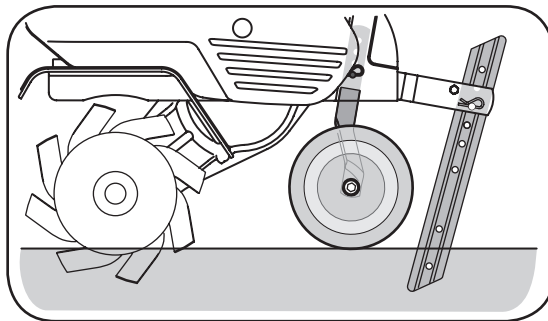

Figure 4-5: Wheel and Yoke back for deeper tilling.

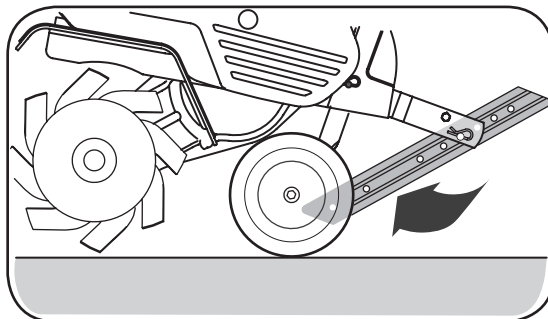

Figure 4-6: Pivot depth stake for transportation.

## Using Your Tiller

Your tiller is designed for seed bed preparation, cultivating, furrowing, and mulching.

### Wheel Position

The tiller is shipped with the wheels adjusted so that the unit sits level. The wheels need to be adjusted to meet your tilling needs before operation. This adjustment is made by removing the clevis pin from the wheel yoke and raising the wheels to the desired height. See Figure 4-3.

## Tilling Depth and Wheel Yoke Adjustment

Placement of wheel yoke will effect depth of tilling.

### Yoke Forward

Place the wheel yoke so that wheels are forward (nearest to tines) for shallow tilling, cultivating and transport. See Figure 4-4.

### Yoke to Back

Place the wheel yoke so that wheels are toward rear (closest to depth stake) for deep tilling and cultivating. See Figure 4-5.

### Depth Stake

The depth stake acts as a brake for the tiller and controls the depth and speed at which the machine will operate. Remove the clevis pin and hairpin clip to raise or lower depth stake. See Figure 4-6.

### Handle Pressure

Further control of tilling depth and travel speed can be obtained by variation of pressure on the handles.

A downward pressure on the handles will reduce the working depth and increase the forward speed. An upward pressure on the handles will increase the working depth and reduce the forward speed.

The type of soil and working conditions will determine the actual setting of the depth stake and the handle pressure required.

## Transporting and Storing the Tiller

To transport and store the tiller move the throttle to the stop position. Pivot the depth stake away from ground up between wheels. See Figure 4-6.

## Tilling Procedure

When tilling, leave approximately eight inches of untilled soil between the first and second tilling paths, then make the third path between the first and second, Figure 4-7. In some soils, the desired depth is obtained the first time over the garden. In other soils, the desired depth is obtained by going over the garden two or three times. Passes should be made across the length and width of the garden alternately. Rocks which are turned up should be removed from the garden area.

With the outer tines installed, the working width of the machine is 24 inches. This width may be expanded to 26 inches by removing the clevis and cotter pins, sliding each outer tine outward away from the center of the unit and resealing the pins in the holes provided. See Figure 4-8.

## Removing End Caps

The end cap, which is used to avoid tilled soil from overflowing onto unwanted areas, are removable from the axle. Remove the hairpin clip and clevis pin that secure each end cap and slide the end caps off the axle. See Figure 4-9.

## Cultivating

For cultivating, a two to three inch depth is desirable. The tine width can be reduced to 13 inches by removing the outer tines completely from the tiller. See figure 4-8. When laying out plant rows, be sure to allow enough width to permit cultivation between the rows. In growing corn or similar crops, check-row planting will permit cross cultivation and practically eliminate hand hoeing. Figure 4-10.

The tiller has many uses other than tilling and cultivating a garden. One of these is the preparation of lawn area for seeding. The tiller will prepare a deep seed bed which will be free of hard untilled spots, allowing a better stand of grass to grow. The tiller is very useful for loosening hard soil for excavation with a shovel; No tedious handwork will be necessary. Your tiller may be used for mixing compost in the pile or for mixing it with the soil in your garden. This should be done after the soil has been broken to the full working depth. The compost should be worked in to a depth of six to seven inches. This may be done by working the length of the garden and then by making separate passes across its width. The addition of decayed organic matter will substantially increase the fertility of your garden. For proper decaying action, fertilizer should be applied and worked in with the mulch materials. Breaking up leaves and straw and mixing it with several inches of soil allows proper aeration of the plant root system and retards the growth of weeds.

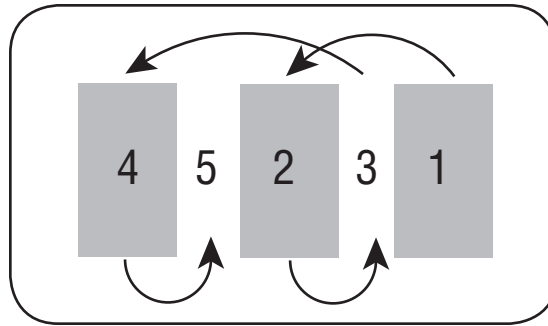

Figure 4-7: Recommended tiller paths.

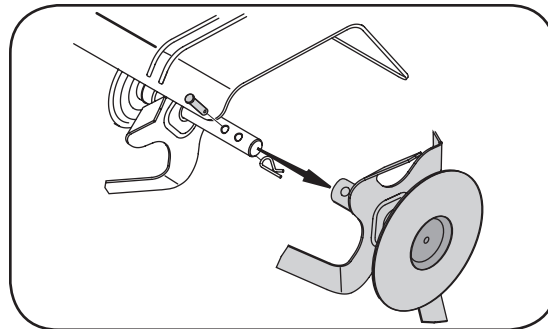

Figure 4-8: Moving and removing outer tines.

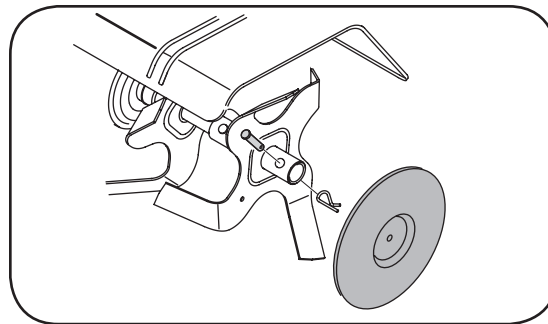

Figure 4-9: Removing end caps.

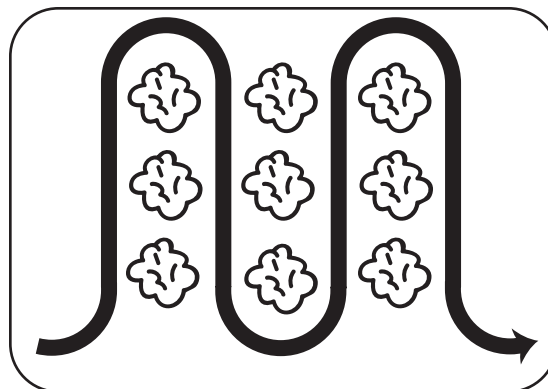

Figure 4-10: Allow area between rows for cultivation.

# 4

## Operating Your Tiller



### WARNING

Be sure no one other than the operator is standing near the tiller while starting engine or operating the unit. Never run engine indoors or in enclosed, poorly ventilated areas. Engine exhaust contains carbon monoxide, an odorless and deadly gas. Keep hands, feet, hair and loose clothing away from any moving parts on engine and tiller.



Refer to the engine manual for detailed instructions pertaining to engine controls.

# 5

## Maintaining Your Tiller



### WARNING

Disconnect the spark plug wire and ground it against the engine before performing any repairs or maintenance.



**WARNING:** Disconnect the spark plug wire and ground it against the engine before performing any repairs.

### Engine

Refer to the separate engine manual for engine maintenance instructions.

Maintain **engine oil** as instructed in the separate engine manual packed with your unit. Read and follow instructions carefully.

Service **air cleaner** every ten hours under normal conditions. Clean every hour under extremely dusty conditions. Poor engine performance and flooding usually indicates that the air cleaner should be serviced. To service the air cleaner, refer to the separate engine manual packed with your unit.

**IMPORTANT:** Never run your engine without air cleaner completely assembled.

The **spark plug** should be cleaned and the gap reset every 25 hours of engine operation. Spark plug replacement is recommended at the start of each tiller season; check engine manual for correct plug type and gap specification.

**Clean the engine** regularly with a cloth or brush. Keep the cooling system (blower housing area) clean to permit proper air circulation which is essential to engine performance and life. Be certain to remove all dirt and combustible debris from muffler area.

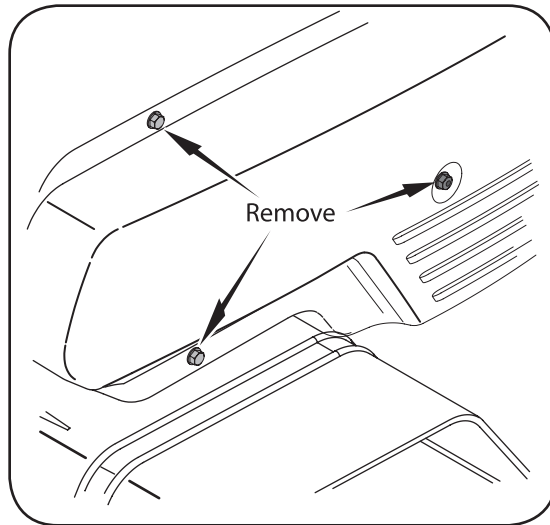

Figure 5-1: Screw and nut removal.

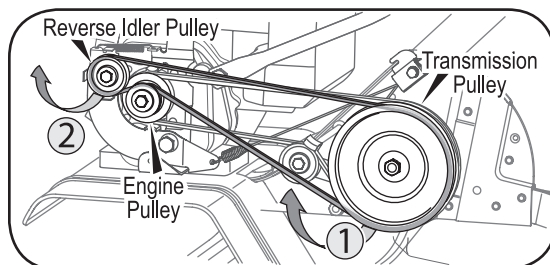

Figure 5-2: Reverse drive belt removal.

## Lubrication

### Pivot Points

Remove the belt cover and lubricate all pivot points and linkages at least once a season with light oil. Keep belts free of lubrication.

### Tine Shafts

Remove tine assemblies and lubricate the tine shafts at least once a season.

### Wheel Shafts

Remove wheel assemblies and lubricate the axle shafts at least once a season.

### Chain Drive

The chain drive is pre-lubricated and sealed at factory.

## Cleaning Tine Area

Clean underside of the tine shield after each use. The dirt washes off the tines easier if rinsed off immediately instead of after it dries. Always towel dry the tiller afterwards and apply a light coat of oil or silicone to prevent rusting or water damage.

**IMPORTANT:** Never use a "pressure washer" to clean your tiller. Water can penetrate tight areas of the tiller and its chain case and cause serious damage to unit.

## Belt Replacement

### Reverse Drive Belt

Your tiller has been engineered with a belt made of special material (Kevlar Tensile) for longer life and better performance. It should not be replaced with an off-the-shelf belt. Order all belts through your authorized service dealer.

1. Disconnect and ground the spark plug wire against the engine.
2. Remove the belt cover from the left side of the tiller by removing the two self-tapping screws and hex stop nut and washer. See Figure 5-1.
3. Remove belt from transmission pulley and then from around the reverse idler pulley. See Figure 5-2.
4. To reassemble new belt. Follow instructions in reverse order. Be sure to place wider side of belt against transmission and idler pulley while slimmer side goes over the engine pulley. See Figure 5-2.

**NOTE:** Upon reassembly, make certain the belt is routed over the idler pulley and inside of belt keepers by engine pulley. See Figure 5-2.

## Belt Replacement

### Forward Drive Belt

1. Remove reverse drive belt as instructed in the previous section.
2. Remove the return spring. See Figure 5-3.
3. Remove idler pulley bolt and move belt from under idler pulley keeper. See Figure 5-4.
4. The forward idler belt will not clear the belt keepers near the engine pulley. You must remove the reverse idler bracket to allow the belt to move off of the engine pulley. Remove the two securing screws and move the bracket toward the transmission pulley. Retain the screws for reassembly. See Figure 5-5.
5. Remove belt from the reverse idler pulley and then from around the transmission pulley. See Figure 5-6.
6. To reassemble new belt. Follow instructions in reverse order. Be sure to place wider side of belt away from the engine and transmission pulleys.

**NOTE:** Upon reassembly, make certain the idler pulley keeper is as shown in Figure 5-4. Take note of the notch on the bottom of the keeper and alignment when reassembling with the replacement belt.

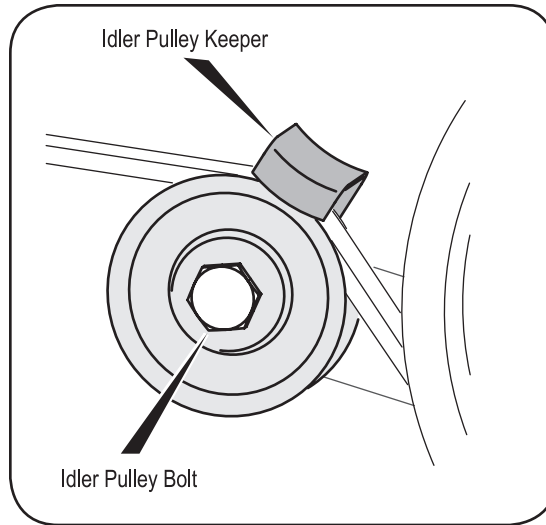

Figure 5-4: Idler pulley keeper belt removal.

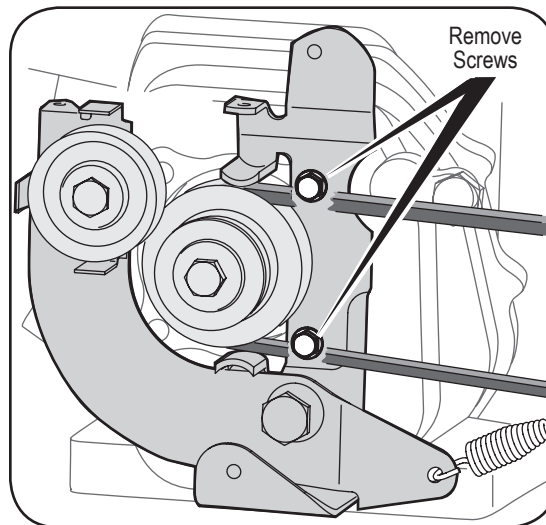

Figure 5-5: Bracket screw removal.

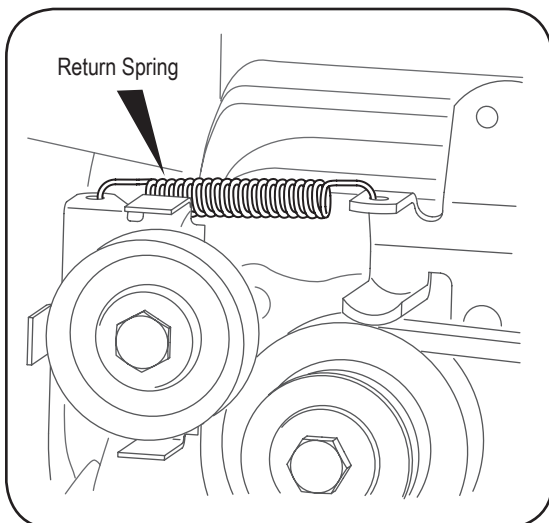

Figure 5-3: Return spring removal.

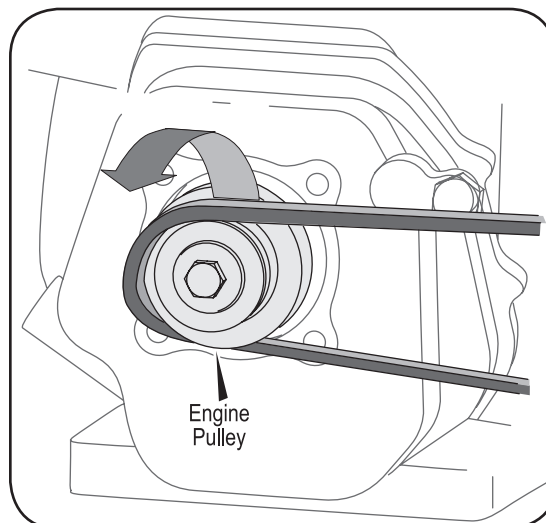

Figure 5-6: Forward drive belt removal.

# 5

## Maintaining Your Tiller



### WARNING

Do not move the gear selection handle with the wheels or tines engaged. Make certain the unit is stopped completely before changing the gear selection. A partial engagement may be necessary when engaging tines.

Do not push down on handles so that wheels are lifted off the ground while using the tine drive, or tiller could move backward and cause personal injury.

Never attempt to make any adjustments while engine is running, except where specified in operator's manual.

# 5

## Maintaining Your Tiller



### WARNING

Disconnect the spark plug wire and ground it against the engine before performing any repairs or maintenance.

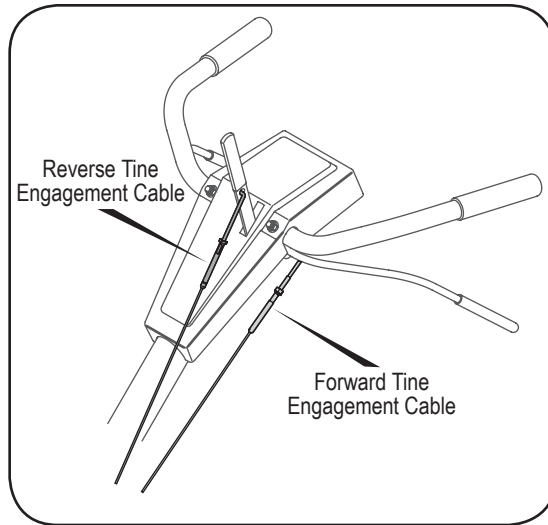

Figure 5-7: Reverse drive belt removal.

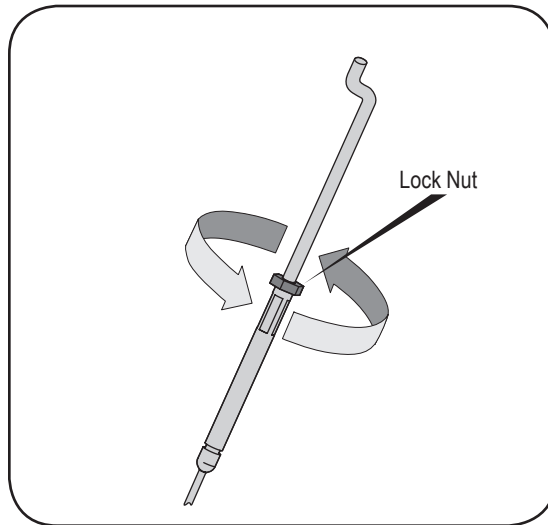

Figure 5-8: Reverse drive belt removal.

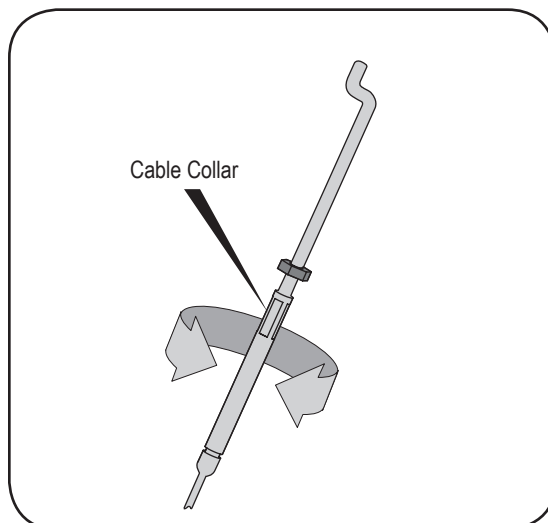

Figure 5-9: Reverse drive belt removal.

## Cable Adjustment

From time to time you may need to adjust the tension on the forward and reverse tine engagement cables.

1. Disconnect and ground the spark plug wire against the engine.
2. Adjust either the forward or reverse clutch cable by loosening the hex nut. See Figure 5-8.
3. Turn the cable collar section one or two turns to add or lesson tension on the cable. See Figure 5-9.
4. Retighten the lock nut against the cable collar. See Figure 5-10.
5. With the forward and reverse tine engagement handles in neutral (released) positions, pull the starter rope several times. The tines should not turn. If they turn forward, adjust the forward tine engagement cable to release tension using the previous steps in this section. If the tines turn toward rear, adjust the reverse tine engagement cable to lesson the tension as with previous steps. Check again for correct tension on cables.

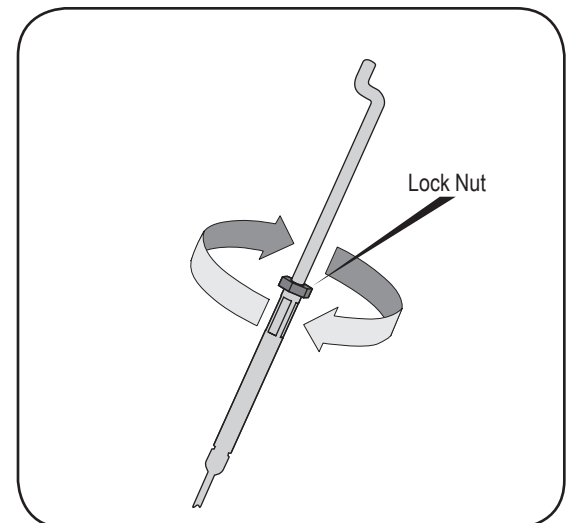

Figure 5-10: Reverse drive belt removal.

## Off-Season Storage

If the tiller will not be used for a period longer than 30 days, the following steps should be taken to prepare the tiller for storage.

1. Clean the exterior of engine and the entire tiller thoroughly. Lubricate the tiller as described in the lubrication instructions.
2. We do not recommend the use of pressure washers to clean your unit. They may cause damage to electric components, spindles, pulleys, bearings or the engine. The use of pressure washers will result in shortened life and reduce serviceability.
3. Refer to the engine manual for correct engine storage instructions.
4. Wipe tines with oiled rag to prevent rust.
5. Store tiller in a clean, dry area. Do not store next to corrosive materials, such as fertilizer.

**NOTE:** When storing any type of power equipment in an unventilated or metal storage shed, care should be taken to rustproof the equipment. Using a light oil or silicone, coat the equipment and especially any springs, bearings, and cables.

Trouble	Possible Cause(s)	Corrective Action
Engine fails to start	Fuel tank empty, or stale fuel.  Throttle control lever not in correct starting position (if so equipped). Blocked fuel line. Dirty air cleaner. Choke not in ON position. Spark plug wire disconnected. Faulty spark plug. Engine flooded.	Fill tank with clean, fresh gasoline. Fuel will not last over thirty days unless a fuel stabilizer is used. Move throttle lever to start position.  Clean fuel line. Refer to the engine manual packed with your unit. Move switch to ON position. Connect wire to spark plug. Clean, adjust gap or replace. Refer to the engine manual packed with your unit.
Engine runs erratic	Unit running on CHOKE. Spark plug wire loose. Blocked fuel line or stale fuel.  Vent in gas cap plugged. Water or dirt in fuel system. Dirty air cleaner. Carburetor out of adjustment.	Move choke lever to OFF position. Connect and tighten spark plug wire. Clean fuel line; fill tank with clean, fresh gasoline. Fuel will not last over thirty days unless a fuel stabilizer is used. Clear vent. Drain fuel tank. Refill with fresh fuel. Refer to the engine manual packed with your unit. Refer to the engine manual packed with your unit.
Engine overheats	Engine oil level low. Dirty air cleaner. Air flow restricted. Carburetor not adjusted properly.	Fill crankcase with proper oil. Refer to the engine manual packed with your unit. Refer to the engine manual packed with your unit. Adjust carburetor as instructed in separate engine manual.
Tines do not engage	Foreign object lodged in tines. Tine clevis pin(s) missing. Pulley and idler not in correct adjustment. Not shifting properly.  Control cable not adjusted properly. Belt worn and/or stretched.	Dislodge foreign object. Replace tine clevis pin(s). Take unit to authorized service dealer.  Refer to Controls section of operator's manual for proper shifting procedures. Adjust control cable (see assembly instructions). Replace belt.
Tines skip over ground	Improper rotation.	Forward rotation should only be used on soil that has already been tilled, not on virgin soil.
Wheels do not engage	Clevis pin missing. Tiller is not being shifted properly.  Control cable not adjusted properly. Belt worn and/or stretched.	Replace clevis pin. Refer to Controls section of operator's manual for proper shifting procedures. Adjust control cable (see assembly instructions). Replace belt.

# 6

## Trouble Shooting Guide



### WARNING

Do not move gear selection handle with the wheels or tines engaged. Make certain the unit is stopped completely before changing the gear selection. A partial engagement may be necessary when engaging tines.

Do not push down on handles so that wheels are lifted off the ground while using tine drive, or the tiller could move backward and cause personal injury.

Never attempt to make any adjustments while the engine is running, except where specified in operator's manual.

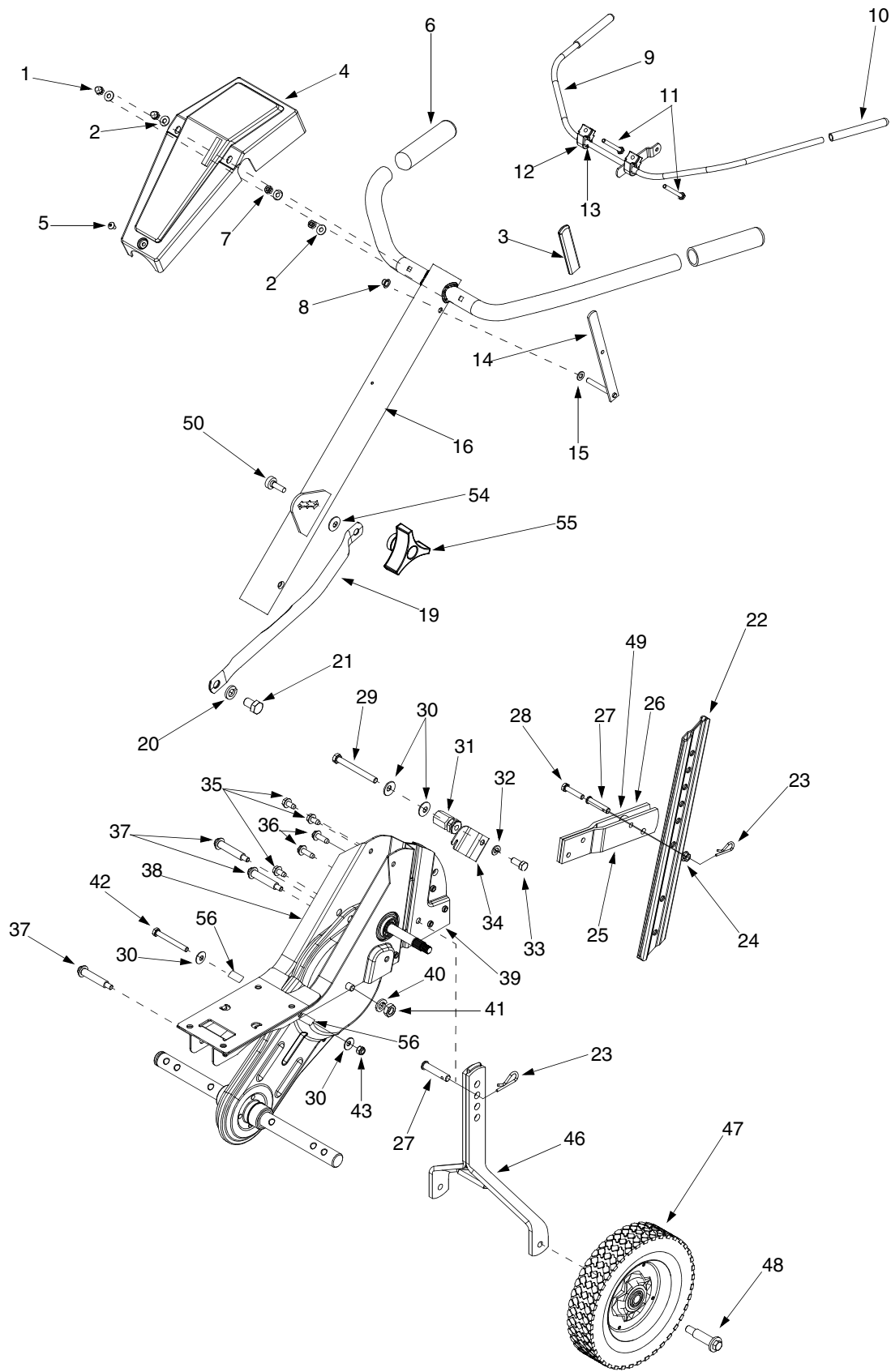



# 9

## Illustrated Parts List

### Model 390 Series



To order replacement parts, contact your local Cub Cadet dealer; or call our dealer locator number at 1 (877) 282-8684; or log onto [www.cubcadet.com](http://www.cubcadet.com)

Ref.	Part No.	Part Description
1	712-0442	Acorn Lock Nut 1/4-20
2	736-3020	Flat Washer.271" I.D. x.630" O.D.
3	720-0270A	Reverse Handle Grip
4	731-1600	Handle Cover w/o throttle
5	710-0779A	Truss Mach. Scr. #10 x 1/2" Lg.
6	720-0274	Handle Grip
7	712-3006	Hex Nut 1/4-20 Gr.2
8	726-0135	Cap Speed Nut
9	686-0083	Clutch Handle Assembly
10	720-0269	Clutch Grip
11	710-0641	Hex Bolt 1/4-20 x 2.25" Lg. Gr.5
12	731-1645A	Clutch Handle Holder
13	736-0140	Flat Washer.385" I.D. x.62" O.D.
14	686-0014A	Reverse Handle Ass'y
15	736-0264	Flat Washer.344" I.D. x.62" O.D.
16	649-04040	Handle Assembly Comp.
19	749-1401	Handle Brace
20	736-0921	Lock Washer 1/2
21	710-3194	Hex Bolt 1/2-20 Gr. 5
22	786-0005	Depth Bar
23	714-0149B	Cotter Pin
24	712-04063	Hex Flange L-Nut 5/16-18 Thd. Gr.5
25	786-0003	Tail Piece Bracket (L.H.)
26	786-0004	Tail Piece Bracket (R.H.)
27	711-0415	Clevis Pin

Ref.	Part No.	Part Description
28	710-0805	Hex Bolt 5/16-18 x 1.5" Lg.
29	710-0189	Hex Bolt 5/16-18 x 3" Lg.
30	736-0242	Wash. Bell.340" I.D. x.872" O.D.
31	711-1036A	Spec. Hex Nut
32	736-0119	L-Wash. 5/16" I.D.
33	710-3008	Hex Bolt 5/16-18 Gr. 5
34	786-0129	Cable Guide Bracket
35	710-0604A	Hex Washer Screw 5/16-18 x.62" Lg.
36	710-0602	Hex Wash. Hd. TT-Tap Scr.
37	738-0934	Shdl. Bolt 5/16-18
38	786-0138A	Frame (R.H.)
39	786-0139A	Frame (L.H.)
40	736-0171	Lock Washer 7/16
41	712-0240	Jam Nut 7/16-20 Gr. 2
42	710-0176	Hex Bolt 5/16-18 x 2.75" Lg.
43	712-0429	Hex Nylon Nut 5/16-18 Thd.
46	686-0081A	Wheel Hanger Bracket Assembly
47	734-1781	Wheel Ass'y 8" x 1.75"(Plastic)
	734-1566	Wheel Ass'y 8" x 1.75" (Steel)
48	738-0929	Shoulder Screw.496 I.D. x 1.445 O.D.
49	750-0890	Spacer
50	710-1236	Carr. Bolt 5/16-18 x 1
51	736-0242	Bell. Wash.34" I.D.
52	720-0195	Hand Knob
53	750-0470	Spacer

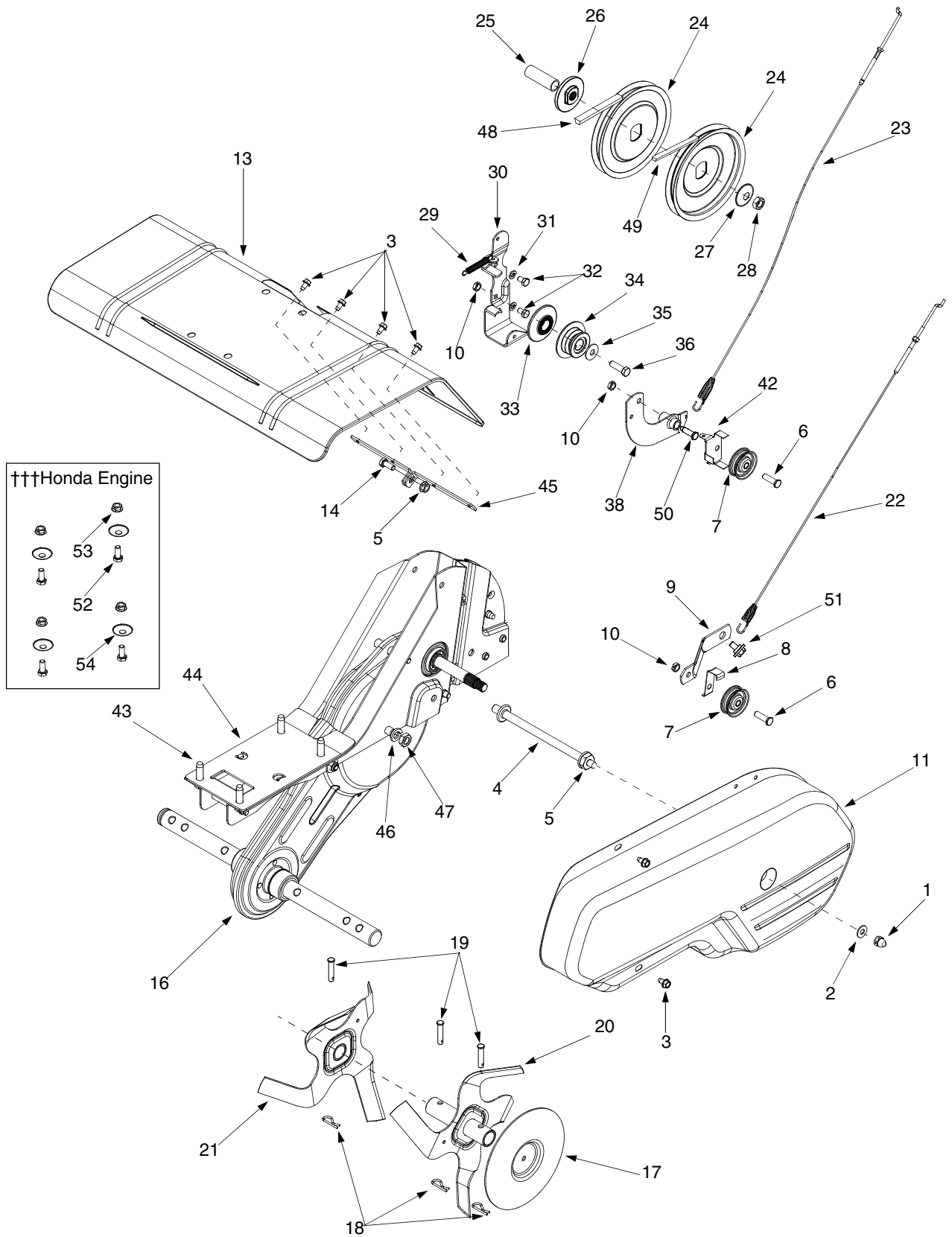

# 9

## Illustrated Parts List

### Model 390 Series



To order replacement parts, contact your local Cub Cadet dealer; or call our dealer locator number at 1 (877) 282-8684; or log onto [www.cubcadet.com](http://www.cubcadet.com)

Ref.	Part No.	Part Description
1	712-0392	Hex L-Stop nut 1/4-28
2	736-3020	Flat Wash.266" I.D. x.625" O.D.
3	710-0599	Hex Washer TT-Tap Scr. 1/4-20 x.5"
4	711-0920	Belt Cover Bolt
5	712-04063	Hex Flange Top L-Nut 5/16-18
6	710-0723	Hex Hd. Scr. 3/8-16 x 1.25" Lg.
7	756-0313	Flat Idler Pulley 2.12" O.D.
8	786-0149	Idler Belt Keeper
9	786-0144	Idler Bracket
10	712-0266	Hex Cent. Jam Nut 3/8-16 Thd.
11	786-0057	Belt Cover
13	786-0043A	Tine Shield
14	710-3008	Hex Hd. Cap Scr. 5/16-18 x.75" Lg
16	686-0091	Chain Case Assembly Complete
17	686-0106	Outer Disc Plate Assembly
18	714-0149B	Internal Cotter Pin
19	711-0415	Clevis Pin
20	642-0023	Outer Tine Assembly L.H.
	642-0024	Outer Tine Assembly R.H.
21	642-0003	Inner Tine Assembly L.H.
	642-0002	Inner Tine Assembly R.H.
22	746-0918	Forward Clutch Cable
23	746-0953	Reverse Clutch Cable
24	756-0585	FI-Pulley 6" Dia.
25	750-0892	Spacer.64" Dia. x 2.4" Lg.

Ref.	Part No.	Part Description
26	748-0350	Pulley Mounting Adapter
27	736-0112	Bell-Wash.525" I.D. x 1.5" O.D.
28	712-3029	Hex Jam Nut 1/2-20 Thd.
29	732-0697	Return Spring
30	786-0040B	Reverse Bracket
31	736-0119	Lock Washer 5/16
32	710-0237	Hex Bolt 5/16-24 x.625"
33	756-0971	Engine Inner Half Pulley
34	756-0600	Reverse Engine Pulley
35	736-0452	Bell Washer.396" I.D. x 1/14" O.D.
36	710-1093	Hex Bolt 3/8-24 x 1.00"
38	686-0013	Reverse Arm Assembly
42	786-0041	Reverse Belt Keeper
43	710-0502A	Hex L-Wash. TT-Tap 3/8-16 x 1.25"
44	786-0145A	Engine Plate
45	786-0053	Tine Shield Bracket
46	736-0171	L-Wash. 7/16" I.D.
47	712-0240	Hex Nut 7/16-20 Thd.
48	754-0428	V-Belt (Forward) 1/2 x 41.9"
49	754-0429	V-Belt (Reverse) 3/8 x 45.68"
50	738-0102	Shld. Screw.498 x 1.445
51	738-0930	Shld. Screw.560 x.165
52	710-0805	Screw 5/16-18 x 1.50
53	712-3010	Hex Nut 5/16-18
54	736-0242	Bell Washer

# MANUFACTURER'S LIMITED WARRANTY FOR

# Cub Cadet®

The limited warranty set forth below is given by Cub Cadet LLC with respect to new merchandise purchased and used in the United States, its possessions and territories.

"Cub Cadet" warrants this product against defects in material and workmanship for a period of two (2) years commencing on the date of original purchase and will, at its option, repair or replace, free of charge, any part found to be defective in materials or workmanship. This limited warranty shall only apply if this product has been operated and maintained in accordance with the Operator's Manual furnished with the product, and has not been subject to misuse, abuse, commercial use, neglect, accident, improper maintenance, alteration, vandalism, theft, fire, water, or damage because of other peril or natural disaster. Damage resulting from the installation or use of any part, accessory or attachment not approved by Cub Cadet for use with the product(s) covered by this manual will void your warranty as to any resulting damage.

Normal wear parts are warranted to be free from defects in material and workmanship for a period of thirty (30) days from the date of purchase. Normal wear parts include, but are not limited to items such as: batteries, belts, blades, blade adapters, grass bags, rider deck wheels, seats, snow thrower skid shoes, shave plates, auger spiral rubber and tires.

**HOW TO OBTAIN SERVICE:** Warranty service is available, WITH PROOF OF PURCHASE, through your local authorized service dealer. To locate the dealer in your area, check your Yellow Pages, or contact Cub Cadet LLC at P.O. Box 361131, Cleveland, Ohio 44136-0019, or call 1-877-282-8684, or log on to our Web site at [www.cubcadet.com](http://www.cubcadet.com).

This limited warranty does not provide coverage in the following cases:

- a. The engine or component parts thereof. These items may carry a separate manufacturer's warranty. Refer to applicable manufacturer's warranty for terms and conditions.
- b. Log splitter pumps, valves, and cylinders have a separate one year warranty.
- c. Routine maintenance items such as lubricants, filters, blade sharpening, tune-ups, brake adjustments, clutch adjustments, deck adjustments, and normal deterioration of the exterior finish due to use or exposure.
- d. Cub Cadet does not extend any warranty for products sold or exported outside of the United States, its possessions and territories, except those sold through Cub Cadet's authorized channels of export distribution

- e. Replacement parts that are not genuine Cub Cadet parts.
- f. Service completed by someone other than an authorized service dealer.
- g. Transportation charges and service calls.

**No implied warranty, including any implied warranty of merchantability of fitness for a particular purpose, applies after the applicable period of express written warranty above as to the parts as identified. No other express warranty, whether written or oral, except as mentioned above, given by any person or entity, including a dealer or retailer, with respect to any product, shall bind Cub Cadet. During the period of the warranty, the exclusive remedy is repair or replacement of the product as set forth above.**

**The provisions as set forth in this warranty provide the sole and exclusive remedy arising from the sale. Cub Cadet shall not be liable for incidental or consequential loss or damage including, without limitation, expenses incurred for substitute or replacement lawn care services or for rental expenses to temporarily replace a warranted product.**

Some states do not allow the exclusion or limitation of incidental or consequential damages, or limitations on how long an implied warranty lasts, so the above exclusions or limitations may not apply to you.

In no event shall recovery of any kind be greater than the amount of the purchase price of the product sold. **Alteration of safety features of the product shall void this warranty.** You assume the risk and liability for loss, damage, or injury to you and your property and/or to others and their property arising out of the misuse or inability to use the product.

This limited warranty shall not extend to anyone other than the original purchaser or to the person for whom it was purchased as a gift.

**HOW STATE LAW RELATES TO THIS WARRANTY:** This limited warranty gives you specific legal rights, and you may also have other rights which vary from state to state.

**IMPORTANT:** Owner must present Original Proof of Purchase to obtain warranty coverage.

**Cub Cadet LLC, P.O. BOX 361131 CLEVELAND, OHIO 44136-0019; Phone: 1-877-282-8684**

## Free Manuals Download Website

<http://myh66.com>

<http://usermanuals.us>

<http://www.somanuals.com>

<http://www.4manuals.cc>

<http://www.manual-lib.com>

<http://www.404manual.com>

<http://www.luxmanual.com>

<http://aubethermostatmanual.com>

Golf course search by state

<http://golfingnear.com>

Email search by domain

<http://emailbydomain.com>

Auto manuals search

<http://auto.somanuals.com>

TV manuals search

<http://tv.somanuals.com>