

# Cuisinart®



**Filter Brew™ Coffeemaker**

**DCC-900**

---

## IMPORTANT SAFEGUARDS

When using electrical appliances, basic safety precautions should always be followed to reduce the risk of fire, electric shock and/or injury to persons, including the following:

### 1. READ ALL INSTRUCTIONS

2. Do not touch hot surfaces. Use handles and knobs.
3. To protect against electric shock, do not place cord, plug, or base unit in water other liquids.
4. Close supervision is necessary when any appliance is used by or near children.
5. **Always unplug from outlet when not in use and before cleaning.** Allow to cool before putting on or taking off parts and before cleaning the appliance.
6. Do not operate any appliance with a damaged cord or plug or after the appliance malfunctions or has been dropped or damaged in any manner. Return appliance to the nearest Cuisinart Repair Center for examination, repair, and electrical or mechanical adjustment.
7. The use of accessory attachments not recommended by Cuisinart may cause injuries.
8. Do not use outdoors.
9. Do not let cord hang over edge of table or counter, or touch hot surface.
10. Do not place on or near a hot gas or electric burner, or in a heated oven.

11. Always fill water reservoir first, then plug cord into the wall outlet. To disconnect, turn controls to "off", then remove plug from wall outlet.
12. Do not use appliance for other than intended use.
13. Snap lid securely onto carafe before serving any beverages.
14. Scalding may occur if the lid is removed during the brewing cycle.
15. The glass carafe is designed for use with these appliances only. It must never be used on the range top.
16. Do not set a hot carafe on a wet or cold surface.
17. Do not use cracked carafe or a carafe having a loose or weakened handle.
18. Do not clean carafe or warming plate with cleansers, steel wool pads, or other abrasive materials.
19. **WARNING: TO REDUCE THE RISK OF FIRE OR ELECTRIC SHOCK, DO NOT REMOVE THE BASE PANEL. NO USER SERVICEABLE PARTS ARE INSIDE. REPAIR SHOULD BE DONE ONLY BY AUTHORIZED PERSONNEL.**
20. Avoid contact with moving parts.

## SAVE THESE INSTRUCTIONS

## FOR HOUSEHOLD USE ONLY

### WARNING: RISK OF FIRE OR ELECTRIC SHOCK



The lightning flash with arrowhead symbol, within an equilateral triangle, is intended to alert the user to the presence of uninsulated "dangerous voltage" within the product's enclosure that may be of sufficient magnitude to constitute a risk of fire or electric shock to persons.



The exclamation point within an equilateral triangle is intended to alert the user to the presence of important operating and maintenance (servicing) instructions in the literature accompanying the appliance.

---

## SPECIAL CORD SET INSTRUCTIONS

A short power-supply cord is provided to reduce the risks resulting from becoming entangled in or tripping over a longer cord. Longer extension cords are available and may be used if care is exercised in their use. If a long extension cord is used, the marked electrical rating of the extension cord must be at least as great as the electrical rating of the appliance, and the longer cord should be arranged so that it will not drape over the counter top or table top where it can be pulled on by children or tripped over.

## NOTICE

This appliance has a polarized plug (one blade is wider than the other.) To reduce the risk of electric shock, this plug will fit in a polarized outlet only one way. If the plug does not fit fully in the outlet, reverse the plug. If it still does not fit, contact a qualified electrician. Do not modify the plug in any way.

## OPERATING NOTICE

Clogging and backing up of water and/or coffee in the filter basket can occur under any or a combination of any of the following conditions: The use of too finely ground coffee; using two or more paper filters; using the gold tone filter in conjunction with a paper filter or not properly cleaning coffee grounds from the gold tone filter; or allowing coffee grounds to spill over the filter.

**Caution:** Never open the top cover during the brewing cycle, even if no water is draining from

the filter basket, since extremely hot water/coffee can spill out from the spreader and cause injury. If water/coffee is not draining from the filter basket during the brewing cycle, unplug the unit and wait 10 minutes before opening the top cover and checking the filter basket.

## IMPORTANT UNPACKING INSTRUCTIONS

1. Place the box on a large, sturdy flat surface.
2. Remove the instruction book and any other literature.
3. Turn the box so that the back side of the coffeemaker is down and slide the coffeemaker from the box.
4. After the coffeemaker has been removed, place the box out of the way and lift off the top two polyfoam inserts.
5. Remove the cardboard insert between the carafe lid and Brew Pause mechanism by sliding it out of the unit.
6. Grasp the carafe by its handle, remove it from the heater plate and remove the polybag.
7. Lift the coffeemaker off the remaining two inserts and remove the polybag covering the coffeemaker.

We suggest you save all packing materials in the event that future shipping of the machine is needed.

Keep all plastic bags away from children.



---

## TABLE OF CONTENTS

Important Safeguards . . . . .	Page 1
Unpacking Instructions . . . . .	Page 2
Introduction . . . . .	Page 3
The Quest for the Perfect Cup of Coffee . . . . .	Page 3
Features and Benefits . . . . .	Page 4
Making Coffee . . . . .	Page 6
Cleaning and Maintenance . . . . .	Page 7
Decalcification of Metal Parts . . . . .	Page 7
Replacing the Water Filter . . . . .	Page 7
Warranty . . . . .	Page 8

## INTRODUCTION

Congratulations on your purchase of the Cuisinart® Filter Brew™ Coffeemaker. This easy to use coffeemaker has a top of the line brewing system with a charcoal filter that makes pure, great tasting coffee possible every time. You decide how many cups you want to make without altering the flavor of the brew. Or if you choose, the Brew Pause™ feature will let you sneak a cup before the brewing cycle is complete. We also included an automatic shutoff feature that turns the machine off after 2 hours in case you forget. Your Filter Brew™ is easy to use, easy to clean and looks great on any kitchen counter top.

## THE QUEST FOR THE PERFECT CUP OF COFFEE

It is generally agreed that there are four basic elements critical to the perfect cup:

### Element 1: Water

Coffee is 98% water. Often overlooked, the quality of the water is as important as the quality of the coffee. A good rule of thumb is that if your water doesn't taste good from the tap, it won't taste any better in your coffee. That is why Cuisinart has added a built-in water filter to the Filter Brew™. The charcoal water filter removes chlorine, bad tastes, odors and scale for the purest cup of coffee every time.

### Element 2: Coffee

While the bulk of the liquid is water, all of the

flavor should be in the coffee. Don't expect to achieve the same quality cup of coffee you're accustomed to drinking at a coffee bar if you don't use the same quality beans or grounds. If you choose to grind your own beans before brewing be sure to buy them fresh, ideally no more than a two week supply at a time, and buy them whole. Once the bean is broken, its flavor degrades very quickly, so coffee should be ground just prior to brewing. If it is not practical to buy small supplies, we recommend you separate larger amounts of beans into one to two week portions immediately after purchase and freeze them in airtight containers. The best way to maximize freshness is to minimize exposure to air, light and moisture. So, once removed from the freezer, maintain the beans in a sealed container at room temperature since damaging condensation occurs every time the beans are removed from the freezer or refrigerator. Note that some coffee experts advise against freezing dark-roast beans because it can cause the oils to coagulate, while others disagree. We suggest you experiment and decide for yourself.

### Element 3: Grind

The grind is critical in proper flavor extraction. If the grind is too fine, overextraction and bitterness will result; too fine a grind may also clog your filter. If too coarse, the water will pass too quickly and the desired flavors will not be extracted. We recommend a medium-fine grind.

### Element 4: Proportion

The cups on the Cuisinart coffeemaker are 4.5 ounces. Add the desired amount of ground coffee, corresponding to the number of cups being brewed. Many coffee bars and the Specialty Coffee Association of America recommend adding 2 rounded tablespoons of coffee per 6 ounces of water. Some coffee manufacturers recommend using one tablespoon per cup. We recommend using 1 tablespoon of ground coffee per cup, but use more or less to suit your taste.

**NOTE: The maximum capacity for ground coffee is 15 tablespoons for this 12 cup coffeemaker. Exceeding these amounts may cause overflow if the coffee is too finely ground.**

---

## FEATURES AND BENEFITS

We designed the Cuisinart® Filter Brew™ to produce great tasting coffee and still be easy to use and easy to clean. A flip top cover allows for easy access to the water reservoir, coffee filter basket and water filter. We made a water reservoir with a large fill area for easy filling from both the front and sides of the unit and to minimize spills. Our unique showerhead evenly distributes the water over the coffee, reducing temperature loss as water passes through coffee grounds. A water filter guarantees the purest coffee and the handgrip on the filter holder makes it easy to place and remove. This coffeemaker also features a heat resistant carafe with a comfortable grip, a knuckle guard to prevent accidental burns, and a dripless pour spout.

The coffeemaker will automatically shut off after 2 hours if you do not so after brewing.

- 1. Reservoir Cover**  
Flips back for easy filling.
- 2. Water Reservoir**
- 3. Filter Basket** (not shown)  
Holds #4 paper cone filter or permanent filter.
- 4. Filter Basket Holder**
- 5. Water Window**  
Markings indicate amount of water needed to make corresponding cups of brewed coffee.
- 6. Showerhead** (not shown)  
Designed for even distribution of water onto coffee and minimizes temperature loss of water passing through the grounds.
- 7. Water Filter** (not shown)  
Charcoal water filter eliminates chlorine, calcium, bad tastes and odors from tap water.
- 8. Carafe**  
The easy pour carafe has an ergonomic handle and brewed coffee markings, for 2 to 12 cups.
- 9. Brew Pause™ Feature**  
Stops flow of coffee from basket when carafe is removed (30 seconds max.) from heater plate so a cup can be poured in mid-brew, if desired. Since the extraction rate varies during the brew cycle, we recommend allowing the brewing cycle to finish before pouring the coffee.
- 10. Heating Plate**  
Scratch resistant with black, non-stick coating.
- 11. 1-4 Cup Setting**  
Adjusts the speed of water flow to improve the flavor of a smaller quantity of brewed coffee.
- 12. 'On/Off' Switch**
- 13. Cord Storage** (not shown)  
Unused cord is easily pushed into the back of the coffeemaker to keep counters neat.
- 14. Grounds Scoop** (not shown)
- 15. Gold Tone Filter** (not shown)

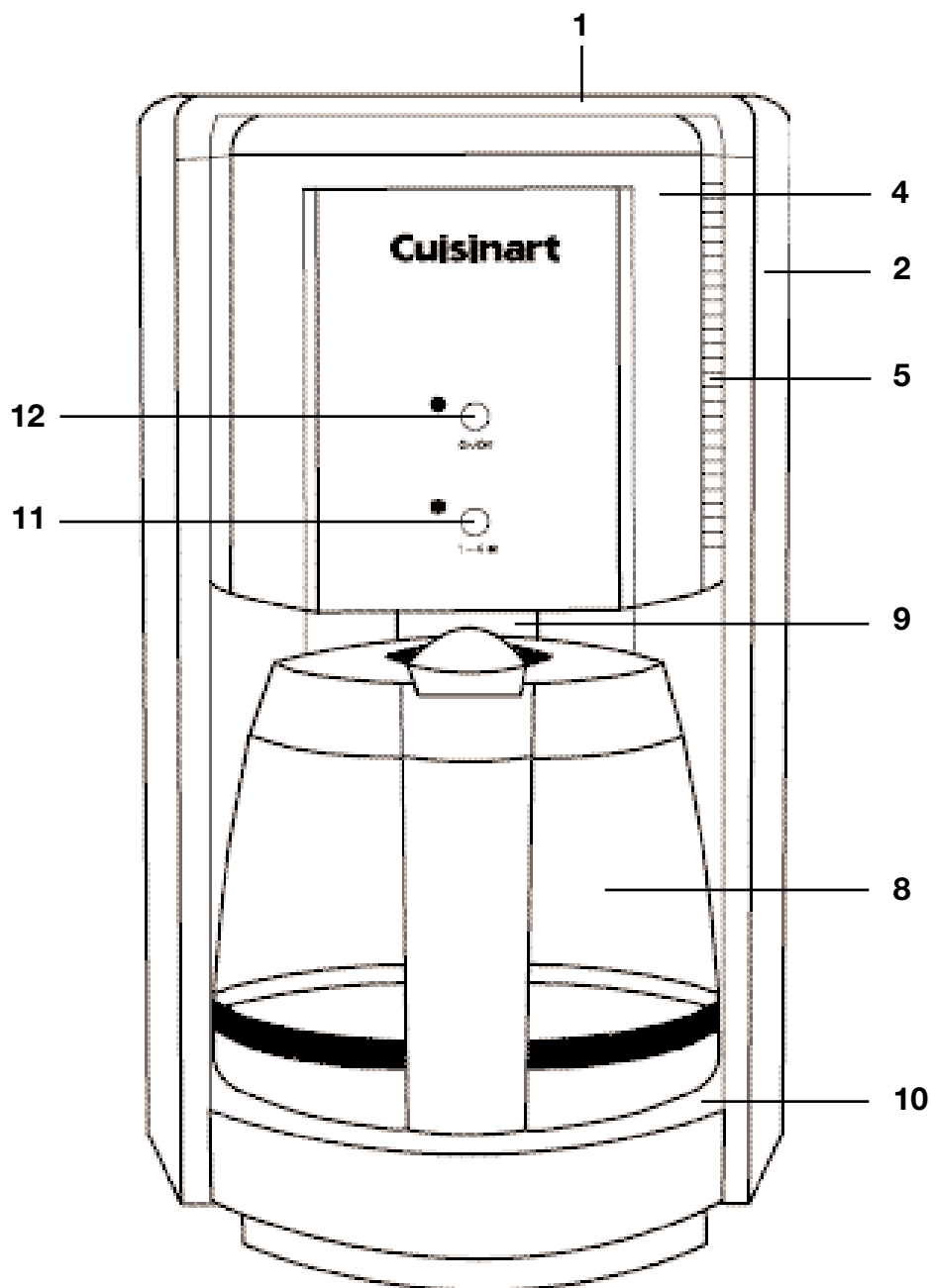

---

## MAKING COFFEE

Before making the first pot of coffee in your new Cuisinart® Filter Brew™, we recommend operating the coffeemaker once using only water and a filter paper. This will remove any dust or residues in the system that remain from the manufacturing process.

### 1. Insert the water filter:

#### To install the filter:

1. Remove the filter from polybag and soak in cold tap water for 15 minutes.
2. Remove the water filter holder from the coffeemaker by lifting it out of the reservoir area with your thumb and forefinger.
3. Hold the water filter holder lengthwise and place thumbs in slots directly under arrows.
4. Pull open in opposite directions with thumbs.
5. Place the filter in the holder recess area at the bottom of the water filter holder.

**NOTE: It will only fit correctly in one end of this unit**

6. Close the water filter holder; you will hear a snap indicating it is in place.
7. Hold the filter under cold running tap water for 10 seconds to flush. You should place the hole openings in the side of the unit directly under the water stream.
8. Allow the filter to drain completely.
9. Replace the water filter holder in the reservoir area of the coffeemaker, pushing it all the way down to the base of the unit.

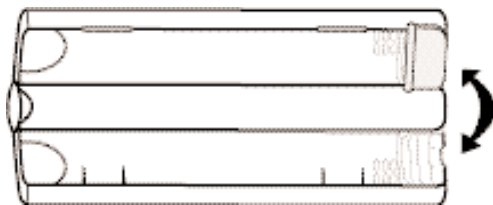

**Note: We recommend changing the water filter every 60 days or 60 uses, more often if you have hard water.**

### 2. Fill the water reservoir:

Remove the carafe from the heating plate. Open the carafe cover and fill with cold water to just over the amount of coffee you are making. Close the carafe cover. Lift the lid of the coffeemaker and pour the water from the carafe into it. The numbers on the water reservoir indicate a slightly higher amount of water per cup than the carafe markings. This is to account for the amount of water lost in wetting the grounds and lost as steam during the brewing process. The float on the water window indicates the amount of water necessary to brew the corresponding amount of coffee.

### 3. Add ground coffee:

Lift filter basket up from holder to remove. Insert #4 paper or permanent filter. Be sure that the filter is completely open and fully inserted in the basket. It may help to fold and flatten the seams of a paper filter beforehand. Add the desired amount of ground coffee, corresponding to the number of cups being brewed. Many coffee bars and the Specialty Coffee Association of America recommend adding two tablespoons of coffee per 6 ounces of water. Some manufacturers recommend using one tablespoon per cup. We recommend using 1 tablespoon of ground coffee per cup, but use more or less to suit your taste.

**NOTE: The maximum capacity for ground coffee is 15 tablespoons for this 12 cup coffeemaker. Exceeding these amounts may cause overflow if the coffee is too finely ground.**

Replace filter basket in filter basket holder and flip the water reservoir lid closed. Be sure that it closes securely in place.

### BEFORE BREWING:

Make sure you have replaced the glass carafe in its position on the heating plate and closed the top cover.

### 4. Power unit:

Plug cord into electrical outlet. Switch control panel to on. The indicator will light.

### 5. Select cups setting:

If you are brewing fewer than 5 cups, activate the '1-4' setting using the push button. The indicator light will only come on

---

if the coffeemaker has been turned on.

#### **6. During and after brewing:**

The Brew Pause™ feature allows you to remove the carafe from the heater during mid-brew. The brewing process does not stop during this period, only the flow of coffee from the basket stops. Do not remove the carafe for longer than 30 seconds or the coffee may overflow the basket. While we offer this feature, we do not recommend that you pour coffee before the cycle has reached completion, since the coffee brewed at the beginning of the cycle has a flavor profile which is very different from the flavor at the end of the cycle. Removing a cup during the brewing cycle will alter the flavor of the finished pot.

Once the coffee has finished brewing, stir it before serving to blend the flavors. The coffee at the bottom of the carafe will be somewhat stronger than the coffee at the top.

## **CLEANING AND MAINTENANCE**

### **COMPLETELY CLEAN AND DRY ALL PARTS AFTER EVERY USE.**

Always turn coffeemaker OFF and remove the plug from the electrical outlet before cleaning unit. Lift lid of coffee maker and remove the filter basket from its holder. Discard the filter paper and ground coffee. The filter basket can be washed in warm soapy water and rinsed thoroughly, or cleaned in the upper rack of the dishwasher. Once clean, replace the filter basket.

Remove the carafe from the heating plate. Discard any remaining coffee. The carafe and lid can be washed in warm soapy water and rinsed thoroughly, or placed in the dishwasher. The carafe and carafe lid should be placed on the upper rack only.

Do not use scouring agents or harsh cleaners on any part of the coffeemaker.

Never immerse base unit in water or other liquid. To clean base, simply wipe with a clean, damp cloth and dry before storing. Wipe heat-

ing plate with a clean, damp cloth. Never use rough, abrasive materials or cleansers to clean the heating plate. Do not dry the inside of the water reservoir with a cloth as lint may remain.

## **DECALCIFICATION**

Decalcification refers to removing the calcium deposits that form over time on the metal parts of the coffeemaker. For best performance from your Filter Brew™ Coffeemaker, decalcify the base unit from time to time. The frequency depends upon the hardness of your tap water and how often you use the coffeemaker.

If the coffeemaker begins to brew more slowly than usual, or the coffee does not taste the same, use the decalcification feature to clean the interior. To decalcify, use a solution of  $\frac{1}{2}$  white vinegar and  $\frac{3}{4}$  water, filling the water reservoir to capacity. Combine in a container and pour into the water reservoir. Plug the unit into electrical outlet. Turn to the ON position and run until half the amount has brewed (6 cups). Turn the unit to the OFF position and allow to sit for 10 minutes. Return the unit to ON and allow the remainder of the liquid to brew. Repeat the above procedure as many times as necessary until a normal brew rate returns, usually 2-3 times. With each repeated cycle, use a fresh solution of vinegar and water. Run one cycle of fresh, cold water through the unit at the completion of the decalcification before using the unit again to brew coffee.

## **REPLACING THE WATER FILTER**

### **To replace the filter**

1. Remove the new filter from polybag and soak in cold tap water for 15 minutes.
2. Remove the water filter holder from the coffeemaker by lifting it out of the reservoir area with your thumb and forefinger.
3. Hold the water filter holder lengthwise and place thumbs in slots directly under arrows.
4. Pull open in opposite directions with thumbs



- 
5. Remove the old filter from the holder and discard.
  6. Place the new filter in the holder recess area at the bottom of the water filter holder.

NOTE: It will only fit correctly in one end of this unit

7. Close the water filter holder; you will hear a snap indicating it is in place.
8. Hold the filter under cold running tap water for 10 seconds to flush. You should place the hole openings in the side of the unit directly under the water stream.
9. Allow the filter to drain completely.
10. Replace the water filter holder in the reservoir area of the coffeemaker, pushing it all the way down to the base of the unit.

**Note: We recommend changing the water filter every 60 days or 60 uses, more often if you have hard water.**

Replacement water filters can be purchased in stores or by calling customer service.

## WARRANTY

### THREE YEAR LIMITED WARRANTY

This warranty supersedes all previous warranties on the Cuisinart® Filter Brew™ Coffeemaker.

This warranty is available to consumers only. You are a consumer if you own a Cuisinart® Filter Brew™ Coffeemaker that was purchased at retail for personal, family or household use. Except as otherwise required under applicable state law, this warranty is not available to retailers or other commercial purchasers or owners.

We warrant that your Cuisinart® Filter Brew™ Coffeemaker will be free of defects in material or workmanship under normal home use for three years from the date of original purchase.

We suggest that you complete and return the enclosed warranty registration card

promptly to facilitate verification of the date of original purchase. However, return of the warranty registration is not a condition of these warranties.

If your coffeemaker should prove to be defective within the warranty period, we will repair it (or, if we think it necessary, replace it) without charge to you. To obtain warranty service, please call our Consumer Service Center toll-free at 800-726-0190 or write to:

Cuisinart  
150 Milford Road  
East Windsor, NJ 08520

To facilitate the speed and accuracy of your return, please also enclose \$10.00 for shipping and handling of the product (California residents need only supply proof of purchase and should call 1-800-726-0190 for shipping instructions). Please also be sure to include a return address, description of the product defect, product serial number, and any other information pertinent to the product's return. Please pay by check or money order.

Your Cuisinart® Filter Brew™ has been manufactured to strict specifications and has been designed for use with the Cuisinart coffeemaker authorized accessories and replacement parts for your model. These warranties expressly exclude any defects or damages caused by accessories, replacement parts or other repair service other than those that have been authorized by Cuisinart.

These warranties exclude all incidental or consequential damages. Some states do not allow the exclusion of or limitation of incidental or consequential damages, so the foregoing limitation or exclusion may not apply to you.

#### CALIFORNIA RESIDENTS ONLY

California law provides that for In-Warranty Service, California residents have the option of returning a nonconforming product (A) to the store where it was purchased or (B) to another retail store that sells Cuisinart products of the same type. The retail store shall then, at its choice, either repair the product, refer the consumer to an independent repair facility, replace the product, or refund the purchase price less the amount directly attributable to the consumer's prior usage of the product. If

---

either of the above two options does not result in the appropriate relief to the consumer, the consumer may then take the product to an independent repair facility if service or repair can be economically accomplished. Cuisinart and not the consumer will be responsible for the reasonable cost of such service, repair, replacement, or refund for nonconforming products under warranty.

California residents may also, at their preference, return nonconforming products directly to Cuisinart for repair or, if necessary, replacement by calling our Consumer Service Center toll-free at 800-726-0190. Cuisinart will be responsible for the cost of the repair, replacement, and shipping and handling for such nonconforming products under warranty.

#### **BEFORE RETURNING YOUR CUISINART® PRODUCT**

**Important:** If the nonconforming product is to be serviced by someone other than Cuisinart's Authorized Service Center, please remind the servicer to call our Consumer Service Center to ensure that the problem is properly diagnosed, the product is serviced with the correct parts, and to ensure that the product is still under warranty.

# Cuisinart

SAVOR THE GOOD LIFE™



Cuisinart offers an extensive assortment of top quality products to make life in the kitchen easier than ever. Try some of our other countertop appliances and cookware, and Savor the Good Life™.

[www.cuisinart.com](http://www.cuisinart.com)

©2001 Cuisinart  
Cuisinart® is a registered trademark of Cuisinart.

Cuisinart  
150 Milford Road  
East Windsor, NJ 08520  
Printed in China  
IB-3764B  
00CU13497

## Free Manuals Download Website

<http://myh66.com>

<http://usermanuals.us>

<http://www.somanuals.com>

<http://www.4manuals.cc>

<http://www.manual-lib.com>

<http://www.404manual.com>

<http://www.luxmanual.com>

<http://aubethermostatmanual.com>

Golf course search by state

<http://golfingnear.com>

Email search by domain

<http://emailbydomain.com>

Auto manuals search

<http://auto.somanuals.com>

TV manuals search

<http://tv.somanuals.com>