



# User's Manual

## BATTERY MODULE

BP240V30ART3U

BP240V50ART3U

CyberPower Systems (USA), Inc.

4241 12th Avenue East Suite 400 Shakopee, MN 55379

Phone: 877-297-6937

Fax: 952-403-0009

[www.CPSww.com](http://www.CPSww.com)

K01-0000210-00

## OVERVIEW

The CyberPower Battery modules (BP240V30ART3U / BP240V50ART3U) support 30A/50A polarized plugs, and are designed for variety of CyberPower UPS systems. When combining with the UPS, the Battery module provides extended runtime with a 240VDC external connection. Additional parallel-connected Battery modules provide the UPS for a longer extended runtime operation.

## UNPACKING

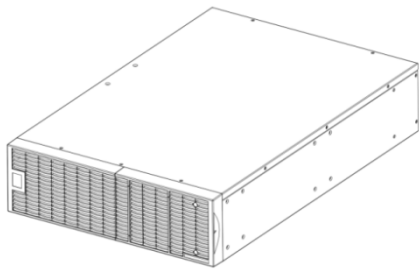

Battery module



User's manual



Register card



Rackmount left rail

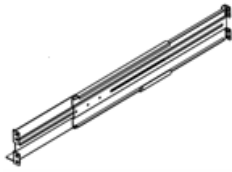

Rackmount right rail

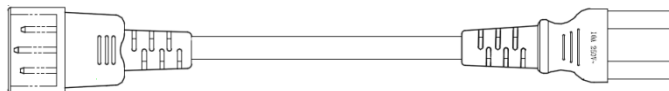

Power cord

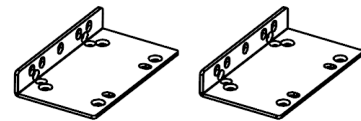

Rackmount ears (Stands) (2) \* 1 set

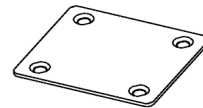

Tie plate (1) \* 1 set



Flat head screws: M5X8L (8) \* 1 set



Pan head screws: M5X12L (12) \* 1 set



Plastic washers (8) \* 1 set



Screw hole dust covers (10) \* 1 set

# HARDWARE INSTALLATION

## **HARDWARE INSTALLATION**

These versatile Battery modules can be mounted in a rackmount or vertical /tower orientation. This versatility is especially important to growing organizations with changing needs that value having the option to position a Battery module on a floor or in a rackmount system. Please follow the instructions below for the respective mounting methods.

## **SAFETY PRECAUTIONS**

**CAUTION!** To prevent the risk of fire or electric shock, only use the supplied hardware to attach the mounting brackets.

## **RACKMOUNT INSTALLATION**

**Step 1: Remove the internal battery trays from the Battery module (See page 7)**

**Step 2: Rackmount ears installation**

Attach the two rackmount ears to the Battery module using the provided screws M5X8L\*8pcs.

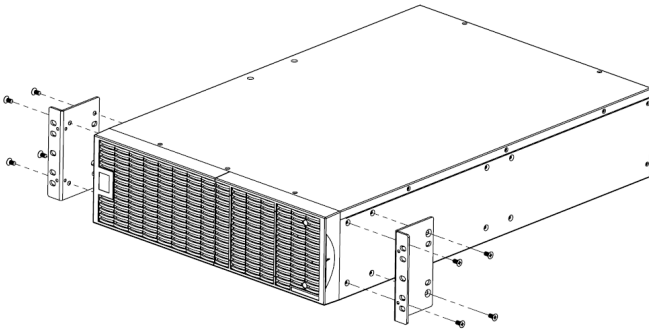

**Step 3: Rackmount rail Installation**

The rails adjust to mount in 48-cm (19-inch) panel racks from 52 to 91.5cm (20.5 to 36 inches) deep. Select the proper holes in the rack for positioning the Battery module in the rack. The Battery module takes up position 1 through position 9.

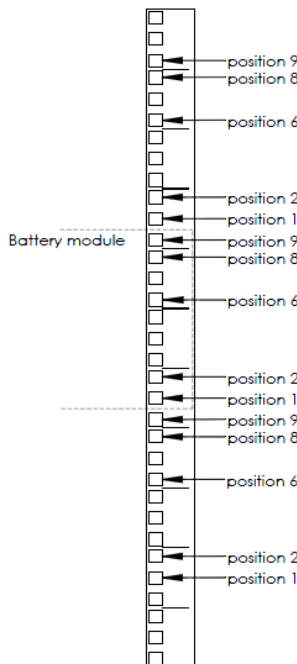

**Step 4: Adjust rackmount rails to fit your rack**

Attach the rackmount rail to your rack with two M5X12L screws and two plastic washers at the front of the rack. (Located in position 1 & position 6) Do not tighten the screws. Adjust the rail size on the rail assembly of your rack. Secure the rail to the rear of the rack with two M5X12L screws and two plastic washers. Tighten all screws at the front and rear of the rail.

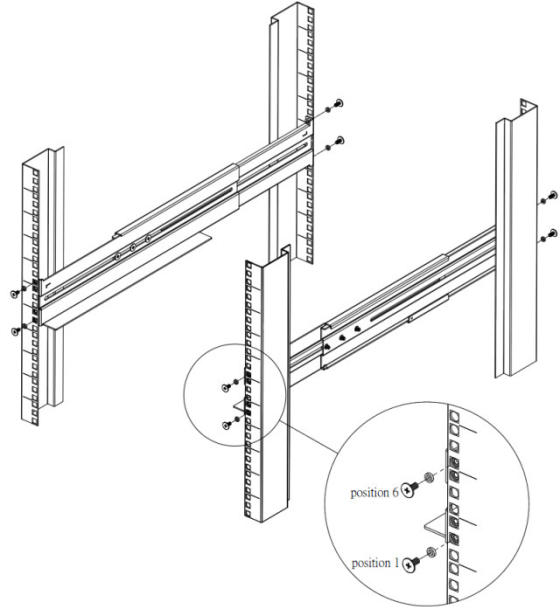

Place the Battery module on a flat stable surface with the front of the unit facing toward you. Secure the Battery module to your rack with four M5X12L screws at the front of the rack. (Located in position 2 & position 8)

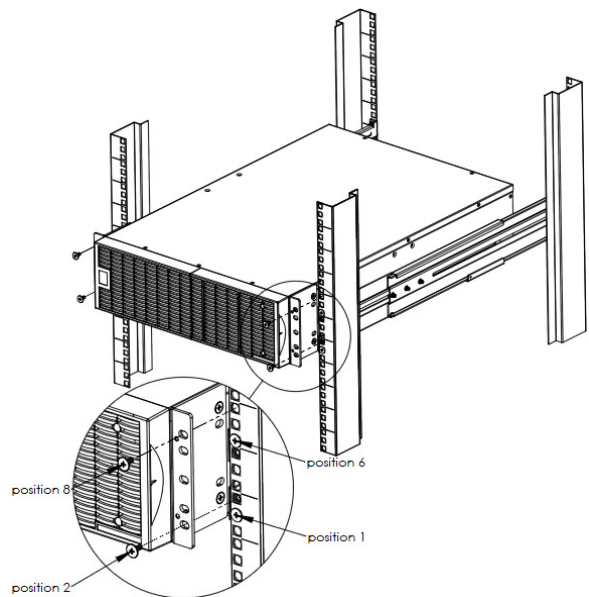

**Step 5: Place the internal battery trays back into the Battery module (See page 7)**

**CAUTION!** The Battery module must be installed below the power module.

## HARDWARE INSTALLATION

### VERTICAL/TOWER INSTALLATION

#### **Step 1: Rotate the Multifunction LCD Module**

Unscrew the right panel of the power module. Separate the right panel from the UPS. Gently lift the LCD module out. Rotate it to the tower orientation. Reinstall it for a tower configuration.

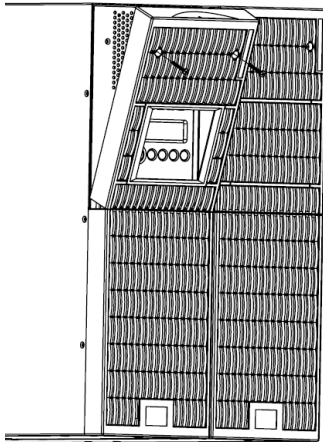
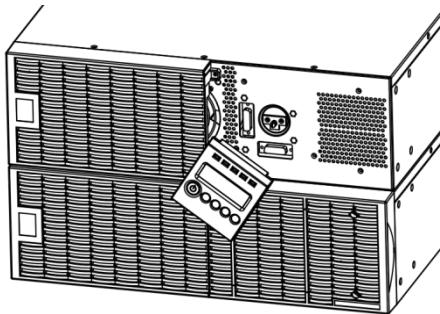
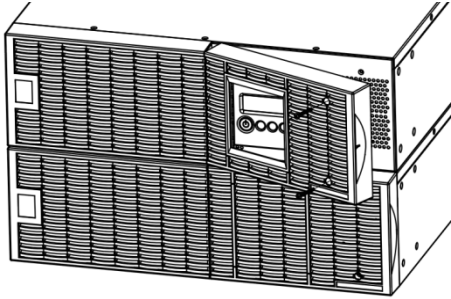

#### **Step 2: Attach the base stands**

Secure the tie bracket with the screws (M5X8\*4pcs). Tighten the screws (M5X12\*4pcs) of the base stands (rackmount ears) onto the bottom of the power module and the Battery module.

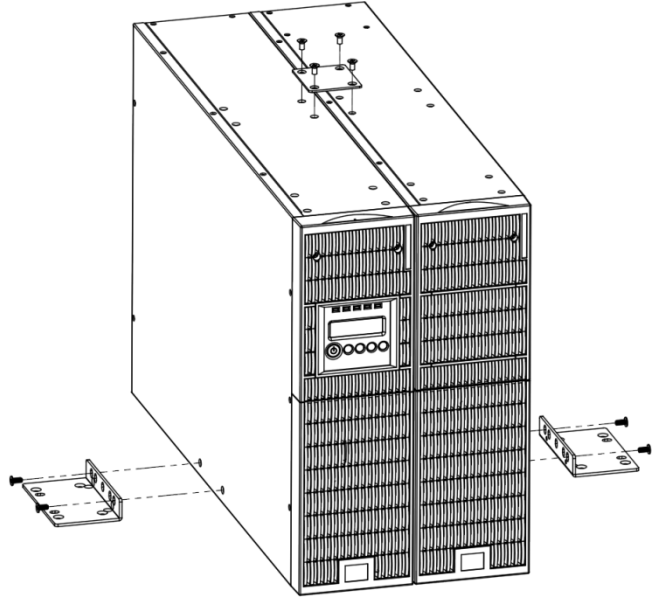

#### **Step 3: Attach dust covers**

Insert dust covers into the rackmount ear, screw holes that are not being used.

### **SAFETY PRECAUTIONS**

**CAUTION!** Installation environment should be in a temperature and humidity controlled indoor area free of conductive contaminants. Do not install this Battery module where excessive moisture or heat is present (Please see specifications for acceptable temperature and humidity range).

**CAUTION!** Never install a Battery module, or associated wiring or equipment, during a lightning storm.

**CAUTION!** Do not work alone under hazardous conditions.

**CAUTION!** In case of the risk of electric shock, do not remove the top cover.

**CAUTION!** The battery can energize hazardous live parts inside even when the AC input power is disconnected.

## BASIC OPERATION

### **BATTERY MODULE FRONT/REAR PANEL DESCRIPTION**

**1. On-board Replaceable Fuse Cover**

Replaceable fuse is accessible from the rear panel. It must be done by qualified personnel.

**2. AC Circuit Breaker**

Provides overload and fault protection.

**3. AC Output Outlet**

Use this outlet to connect to the AC Input Inlet of a downstream Battery module.

**4. AC Input Inlet (Charge Only)**

AC power connectivity to wall receptacle.

**5. Input Connector**

Use this input connector to daisy chain the next Battery module. Remove the connector cover for access.

**6. Output Cable**

Use this output cable to connect the Battery module to the power module or to the next Battery module.

**7. DC Breaker**

Use the DC breaker to disconnect battery output.

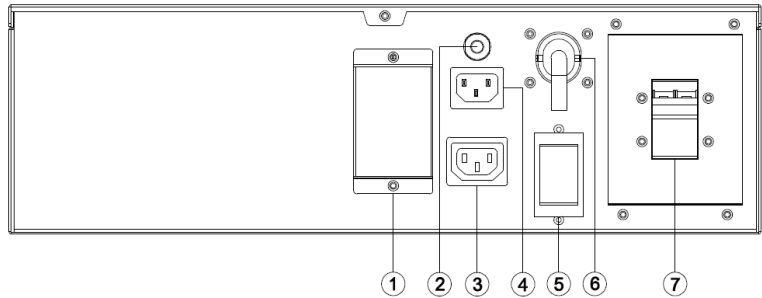
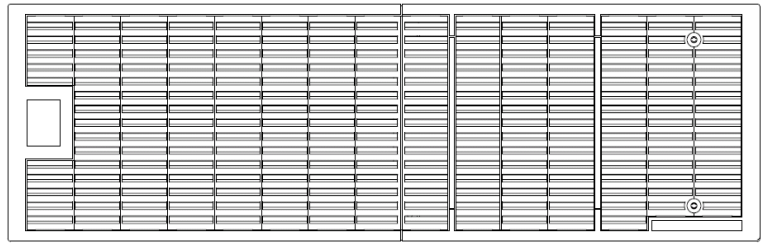

**BP240V30ART3U / BP240V50ART3U**

### **CONNECTION #1 : POWER MODULE WITH ONE BATTERY MODULE**

**Step 1: Turn off the DC breaker of the Battery module.**

**Step 2: Loosen the two screws to remove the battery cable retention bracket of the power module.**

**Step 3: Use the output cable of the Battery module to connect the Battery module to the Power module.**

**Step 4: Rotate the battery cable retention bracket and tighten the two screws to fix battery cable.**

**Step 5: Use a power cord to plug AC input inlet of the battery module into a wall receptacle.**

**Step 6: Turn on the DC breaker of the Battery module.**

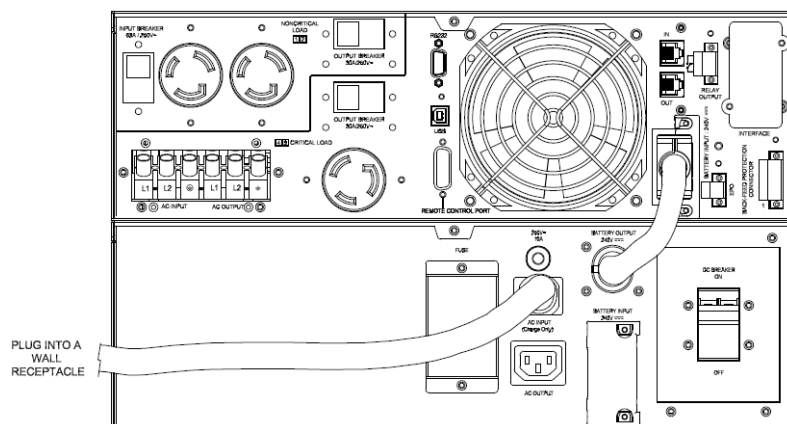
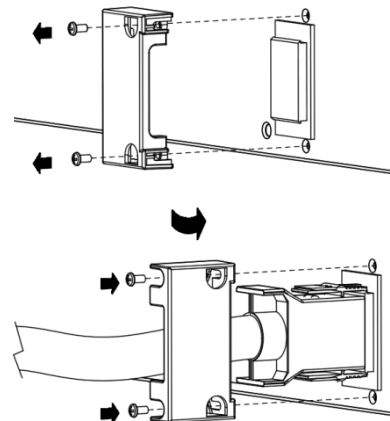

## BASIC OPERATION

### **CONNECTION #2 : POWER MODULE WITH MULTIPLE BATTERY MODULES**

Step 1: Connect the 1<sup>st</sup> Battery module to the Power module using the instructions above.

Step 2: Turn off the DC breaker of the 2<sup>nd</sup> Battery module.

Step 3: Loosen the two screws to remove the battery cable retention bracket of the 1<sup>st</sup> battery module.

Step 4: Use the output cable of the 2<sup>nd</sup> Battery module to connect the 2<sup>nd</sup> Battery module to the 1<sup>st</sup> Battery module.

Step 5: Rotate the battery cable retention bracket and tighten the two screws to fix battery cable.

Step 6: Use a power cord to plug AC input inlet of the 2<sup>nd</sup> battery module into AC output outlet of the 1<sup>st</sup> Battery module.

Step 7: Turn on the DC breaker of the 2<sup>nd</sup> Battery module.

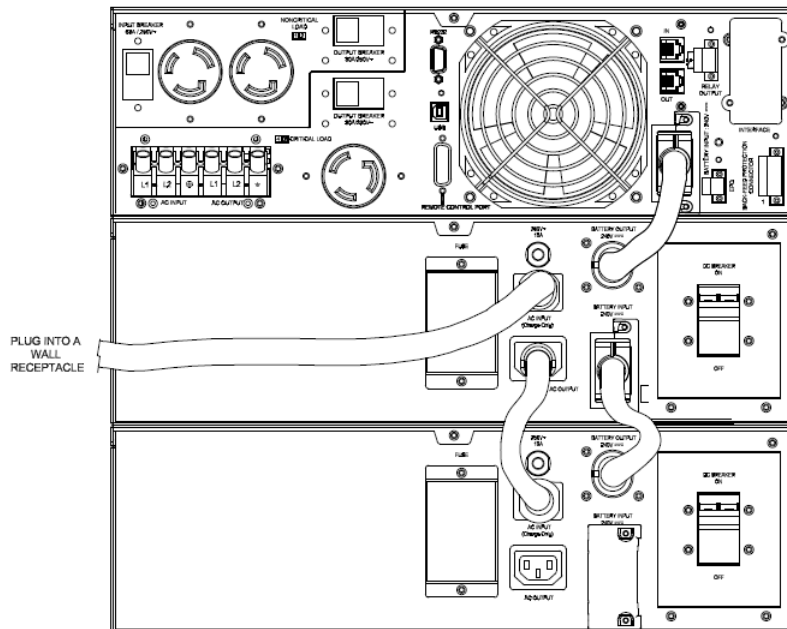
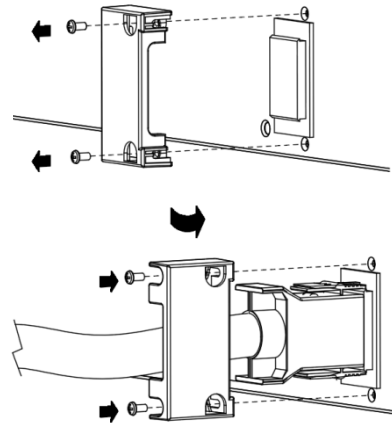

## EXTERNAL BATTERY MODULES CONFIGURATION

**External Battery Modules** can be configured by the user to display correct estimated battery runtimes.

1. Press the “**ENTER**” button to activate the “**MAIN MENU**”.
2. Press the “**▲**” and “**▼**” buttons to scroll to the “**Configure**” option.
3. Press the “**ENTER**” button to select the “**Configure**” submenu.
4. Press the “**▲**” and “**▼**” buttons to scroll to the “**EBP Number**” option.
5. Press the “**ENTER**” button to select the “**EBP Number**” submenu.

The first configuration number will be displayed on the second column of LCD display.

6. Press the “**▲**” and “**▼**” buttons to scroll through the number of attached Battery modules.
7. Press the “**ENTER**” button to select the number of Battery modules installed.

You may be prompted to save the selection, if so press the “**ENTER**” button to save the setting.

8. Press the “**ESC**” button to cancel or return to the previous LCD menu.

Configure Submenu	Available Settings	Default Settings
<b>EBM Number</b>	= [0] [1] [2] [3] [4] [5] [6] [7] [8] [9] [10]	0

## MAINTENANCE

### **Storage**

To store your UPS for an extended period, cover it and store with the battery fully charged. Recharge the battery every three months to ensure battery life.

### **Battery Replacement**

Please read and follow the Safety Instructions before servicing the battery. Battery replacement should be performed by trained personnel who are familiar with the procedures and safety precautions. Make a note of the replacement Battery module number.

### **Safety Precautions**

**CAUTION!** Only use replacement batteries which are certified by CyberPower Systems. Use of incorrect battery type is an electrical hazard that could lead to explosion, fire, electric shock, or short circuit.

**CAUTION!** Batteries contain an electrical charge that can cause severe burns. Before servicing batteries, please remove any conductive materials such as jewelry, chains, wrist watches, and rings.

**CAUTION!** Do not open or mutilate the batteries. Electrolyte fluid is harmful to the skin/eyes and may be toxic.

**CAUTION!** To avoid electric shock, turn off and unplug the Battery module from the wall receptacle before servicing the battery.

**CAUTION!** Only use tools with insulated handles. Do not lay tools or metal parts on top of the UPS or battery terminals.

### **Replacement Batteries**

Please refer to the front side of the Battery module for the model number of the correct replacement batteries. For battery procurement, log onto [www.CPSwww.com](http://www.CPSwww.com), or contact your local dealer.

### **Battery Disposal**

Batteries are considered hazardous waste and must be disposed of properly. Contact your local government for more information about proper disposal and recycling of batteries. Do not dispose of batteries in fire.

### **Battery Installation**

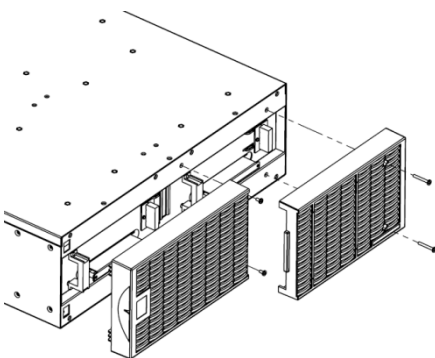

Step 1: Remove the front panels

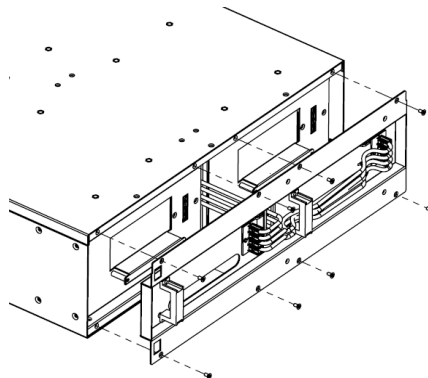

Step 2: Remove the retaining screws from the cable protection cover and then remove the cover itself

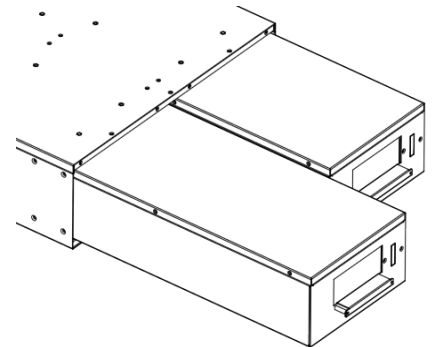

Step 3: Pull the battery trays out slowly and then put the new battery trays back into the compartment

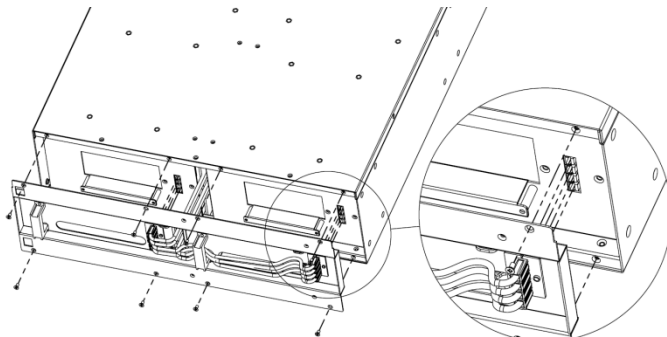

Step 4: Insert the battery connectors and tighten the screws of battery retaining cover

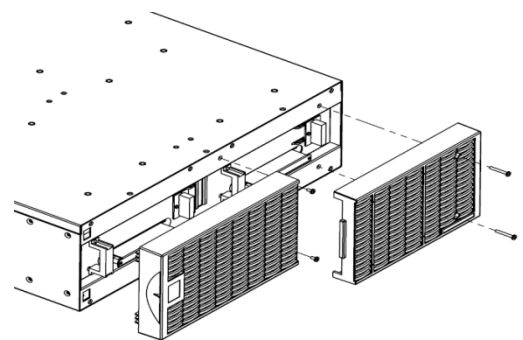

Step 5: Install the front panels



## TECHNICAL SPECIFICATIONS

Model	BP240V30ART3U	BP240V50ART3U
<b>Configuration</b>		
AC Input Voltage	180~280Vac	
DC Output Voltage	240Vdc	
Amperage	30A	50A
<b>Physical</b>		
Dimensions	L x W x H = 26 x 17 x 5.2in. (660 x 433 x 132mm)	
Net Weight	167.2lbs(76Kg)	171.6lbs(78Kg)
<b>Battery</b>		
Specifications	(20) 12V/7.2AH	(20) 12V/9.0AH
Recharge Time (Typically)	4 hours	5 hours
Interface	PP45	
Sealed, Maintenance Free	Yes	
Hot-Swappable	Yes	
Built-in Charger	Yes	
<b>Environment</b>		
Operating Temperature	32°F to 104°F ( 0°C to 40°C)	
Operating Relative Humidity	0 to 90% Non-Condensing	
<b>Safety</b>		
Conformance Approvals	CE, UL	
RoHS	RoHS Compliant	
<b>Warranty</b>		
Product Warranty	3-year limited warranty, Free Tech Support	

## TROUBLE SHOOTING

Problem	Possible Cause	Solution
<b>Warning</b>		
BAT Disconnected	Missing battery power.	Check battery connector and battery breaker.
Battery Failure	UPS has failed in Battery Test.	1. Check battery connector and battery breaker. 2. Contact technical support to replace the battery.
Replace Battery	Battery will soon need to be replaced due to insufficient runtime.	Contact technical support to replace the battery.
<b>Fault</b>		
Over Charge	Battery is overcharged.	1. Remove battery connector and check charger voltage. 2. Contact CyberPower for repair.
Charger Failure	Charger has failed.	

## CUSTOMER SERVICE

If the Battery module requires further service, please refer to the following information:

1. Call us at (877) 297-6937 or write to us at Cyber Power Systems (USA), Inc., 4241 12th Ave. E., STE 400, Shakopee, MN 55379 or send us an e-mail message at tech@cpsww.com for instructions.
2. When you contact CyberPower, identify the Product, the Purchase Date, and the item(s) of Connected Equipment. Have information on all applicable insurance or other resources of recovery/payment that are available to the Initial Customer and Request a Claim Number.
3. You must provide a dated Proof-of-Purchase receipt (or other proof of the original purchase) and provide a description of the defect.
4. Pack and ship the product to CyberPower and, if requested, the item(s) of Connected Equipment, a repair cost estimate for the damage to the Connected Equipment, and all claim forms that CyberPower provides to you. Show the Claim Number on the shipping label or include it with the product.

**You must prepay all shipping costs, you are responsible for packaging and shipment, and you must pay the cost of the repair estimate.**

## PRODUCT REGISTRATION

CyberPower requests that you complete and return the Warranty Registration Card enclosed with the Product or register the Product at its website ([www.cpsww.com](http://www.cpsww.com)) to establish that you are the Initial Customer of the Product, and therefore entitled coverage under the Limited Warranty and the Connected Equipment Guarantee. (Registration is not required for coverage, but note: if you do not register your purchase, you will be required to provide proof of purchase.)

## LIMITED WARRANTY AND CONNECTED EQUIPMENT GUARANTEE

Read the following terms and conditions carefully before using the CyberPower BP240V30ART3U / BP240V50ART3U. By using the Product you consent to be bound by and become a party to the terms and conditions of this Limited Warranty and Connected Equipment Guarantee (together referred to as this "Warranty"). If you do not agree to the terms and conditions of this Warranty, you should return the Product for a full refund prior to using it.

### Who is Providing this Warranty?

CyberPower Systems (USA), Inc. ("CyberPower") provides this Limited Warranty.

### What Does This Warranty Cover?

This warranty covers defects in materials and workmanship in the Product under normal use and conditions. It also covers equipment that was connected to the Product and damaged because of the failure of the Product.

### What is the Period of Coverage?

This warranty covers the Product for three years and connected equipment for as long as you own the Product.

### Who Is Covered?

This warranty only covers the original purchaser. Coverage ends if you sell or otherwise transfer the Product.

### How Do You Get Warranty Service?

1. Before contacting CyberPower, identify Your Product model number, the Purchase Date, and each item of Connected Equipment.
2. Email us at [tech@cpsww.com](mailto:tech@cpsww.com) or Call us at (877) 297-6937.
3. If your product requires warranty service you must provide a copy of your dated purchase receipt or invoice.

### How Do You Open A Connected Equipment Claim?

1. Call us at (877) 297-6937 or write to us at Cyber Power Systems (USA), Inc., 4241 12th Ave. E., STE 400, Shakopee, MN 55379, or send us an e-mail message at [claims@cpsww.com](mailto:claims@cpsww.com) for instructions, within 10 days of the occurrence.
2. When you contact CyberPower, identify the Product, the Purchase Date, and the item(s) of Connected Equipment. Have information on all applicable insurance or other resources of recovery/payment that are available to the Initial Customer and Request a Claim Number.
3. You must provide a dated purchase receipt (or other proof of the original purchase) and provide a description of the damage to your connected equipment.
4. Pack and ship the product to CyberPower and, if requested, the item(s) of Connected Equipment, a repair cost estimate for the damage to the Connected Equipment, and all claim forms that CyberPower provides to you. Show the Claim Number on the shipping label or include it with the product. **You must prepay all shipping costs, you are responsible for packaging and shipment, and you must pay the cost of the repair estimate.**

### How Long Do I Have To Make A Claim?

All claims must be made within ten days of the occurrence.

### What Will We Do To Correct Problems?

CyberPower will inspect and examine the Product.

If the Product is defective in material or workmanship, CyberPower will repair or replace it at CyberPower's expense, or, if CyberPower is unable to or decides not to repair or replace the Product (if defective) within a reasonable time, CyberPower will refund to you the full purchase price you paid for the Product (purchase receipt showing price paid is required).

If it appears that our Product failed to protect any equipment plugged into it, we will also send you forms for making your claim for the connected equipment. We will repair or replace the equipment that was damaged because of the failure of our Product or pay you the fair market value (NOT REPLACEMENT COST) of the equipment at of the time of the damage. We will use Orion Blue Book, or another a third-party valuation guide, or eBay, craigslist, or other source to establish that amount. Our maximum liability is limited to \$300,000 for BP240V30ART3U / BP240V50ART3U.

## LIMITED WARRANTY AND CONNECTED EQUIPMENT GUARANTEE

### Who Pays For Shipping?

We pay when we send items to you; you pay when you send items to us.

### What Are Some Examples Of What This Warranty Does Not Cover?

1. This Warranty does not cover any software that was damaged or needs to be replaced due to the failure of the Product or any data that is lost as a result of the failure or the restoration of data or records, or the reinstallation of software.
2. This Warranty does not cover or apply to: misuse, modification, operation or storage outside environmental limits of the Product or the equipment connected to it, nor for damage while in transit or in storage, nor if there has been improper operation or maintenance, or use with items not designed or intended for use with the Product, such as laser printers, appliances, aquariums, medical or life support devices, etc.

### What Other Limitations Apply?

The sole and exclusive remedies of the Initial Customer are those provided by this Warranty.

1. This Warranty does not apply unless the Product and the equipment that was connected to it were connected to properly wired and grounded outlets (including compliance with electrical and safety codes of the most current electrical code), without the use of any adapters or other connectors.
2. The Product must have been plugged directly into the power source and the equipment connected to the Product must be directly connected to the Product and not "daisy-chained" together in serial fashion with any extension cords, another Product or device similar to the Product, surge suppressor, or power tap. Any such installation voids the Limited Warranty.
3. The Product and equipment connected to it must have been used properly in a suitable and proper environment and in conformance with any license, instruction manual, or warnings provided with the Product and the equipment connected to it.
4. The Product must have been used at all times within the limitations on the Product's VA capacity.

The Product was designed to eliminate disrupting and damaging effects of momentary (less than 1ms) voltage spikes or impulses from lightning or other power transients. If it can be shown that a voltage spike lasting longer than 1ms has occurred, the occurrence will be deemed outside the rated capabilities of the Product and the Limited Warranty is void. CyberPower Does Not Cover or Undertake Any Liability in Any Event for Any of the Following:

1. Loss of or damage to data, records, or software or the restoration of data or records, or the reinstallation of software.
2. Damage from causes other than AC Power Line Transients, spikes, or surges on properly installed, grounded and code-compliant 120 volt power lines in the United States and Canada; transients, surges or spikes on standard telephone land lines, PBX telephone equipment lines or Base 10T Ethernet lines, when properly installed and connected. (This exclusion applies, for example, to fluctuations in data transmission or reception, by CATV or RF transmission or fluctuations, or by transients in such transmission.)
3. Damage from any circumstance described as excluded above with respect to the Product.
4. Damages from fire, flood, wind, rain, rising water, leakage or breakage of plumbing, abuse, misuse or alteration of either the product or the Connected Equipment.
5. CyberPower excludes any liability for personal injury under the Limited Warranty and Connected Equipment Guarantee. CyberPower excludes any liability for direct, indirect, special, incidental or consequential damages, whether for damage to or loss of property [EXCEPT FOR (AND ONLY FOR) the specific limited agreement of CyberPower to provide certain warranty benefits regarding "Connected Equipment" under this Warranty], loss of profits, business interruption, or loss of information or data. NOTE: Some States or Provinces do not allow the exclusion or limitation of incidental or consequential damages, so the above limitation may not apply to you.
6. The Product is not for use in high-risk activities or with aquariums. The Product is not designed or intended for use in hazardous environments requiring fail-safe performance, or for use in any circumstance in which the failure of the Product could lead directly to death, personal injury, or severe physical or property damage, or that would affect operation or safety of any medical or life support device (collectively, "High Risk Activities"). CyberPower expressly disclaims any express or implied warranty of fitness for High Risk Activities or with aquariums. CyberPower does not authorize use of any Product in any High Risk Activities or with Aquariums. **ANY SUCH USE IS IMPROPER AND IS A MISUSE OF THE PRODUCT.**

### Where Can I Get More Information?

The application of the United Nations Convention of Contracts for the International Sale of Goods is expressly excluded.

CyberPower is the warrantor under this Limited Warranty.

For further information please feel free to contact CyberPower at CyberPower Systems (USA), Inc. 4241 12th Ave E., STE 400, Shakopee, MN 55379; call us at (877) 297-6937; or send us an e-mail message at [claims@cyberpowersystems.com](mailto:claims@cyberpowersystems.com).



#### FCC Notice

This device complies with part 15 of the FCC Rules. Operation is subject to the following two conditions: (1) This device may not cause harmful interference, and (2) this device must accept any interference that may cause undesired operation.

**WARNING!!** This equipment has been tested and found to comply with the limits for a Class A digital device, pursuant to part 15 of the FCC Rules. These limits are designed to provide reasonable protection against harmful interference when the equipment is operated in a commercial environment. This equipment generates, uses, and can radiate radio frequency energy and, if not installed and used in accordance with the instruction manual, may cause harmful interference to radio communications. Operation of this equipment in a residential area is likely to cause harmful interference in which case the user will be required to correct the interference at his own expense. Shielded signal cables must be used with this product to ensure compliance with the Class A FCC limits.

**nt Regulation.**  
**uilleur du Canada.**

This document is believed to be accurate, but CyberPower reserves the right to change or correct the contents and does not assume any responsibility for omissions or errors.

#### Need Additional Help?

Feel free to contact our Tech Support department with installation, troubleshooting, or general product questions.

#### CyberPower Technical Support

**Phone: 1-877-297-6937**

**Email: [tech@cpsww.com](mailto:tech@cpsww.com)**

**Web: [www.CPSww.com](http://www.CPSww.com)**

**Mail: 4241 12th Avenue E, Suite 400 Shakopee, MN 55379**

#### Hours of Operation:

**Monday – Friday, 8:00am – 5:00pm (CST)**

Entire contents copyright © 2011 CyberPower Systems, Inc.

All rights reserved. Reproduction in whole or in part without permission is prohibited.

## Free Manuals Download Website

<http://myh66.com>

<http://usermanuals.us>

<http://www.somanuals.com>

<http://www.4manuals.cc>

<http://www.manual-lib.com>

<http://www.404manual.com>

<http://www.luxmanual.com>

<http://aubethermostatmanual.com>

Golf course search by state

<http://golfingnear.com>

Email search by domain

<http://emailbydomain.com>

Auto manuals search

<http://auto.somanuals.com>

TV manuals search

<http://tv.somanuals.com>