

SAFETY IS EVERYONE'S RESPONSIBILITY. ALL DACOR APPLIANCES ARE DESIGNED AND CONSTRUCTED TO GIVE YOU MANY YEARS OF SAFE OPERATION. THE OPERATION WILL BE FURTHER ENHANCED IF PROPER CARE AND JUDGEMENT ARE EXERCISED IN THE USE AND MAINTENANCE OF THIS APPLIANCE.

#### IMPORTANT INFORMATION

- Operating Instructions
- Care and Cleaning Instructions
- Safety Tips



#### WARNINGS:

Must be followed carefully to avoid personal injury or damage.



#### NOTES:

Contains helpful hints and tips.

**Please Read Before Using Your Outdoor Grill**

Place Serial Number Label Here



Dear DACOR Consumer,

Congratulations! You have purchased the very latest in kitchen appliances. Your new DACOR product offers features, styling and performance not found in any other appliance.

Please read this manual before operating your new appliance. It is imperative that you read the IMPORTANT INSTRUCTIONS section and become familiar with the controls and procedures to understand the full potential of this product.

All DACOR appliances are designed and manufactured to meet the highest quality standards. Each unit is thoroughly tested. Should you have a problem, however, please first check the PROBLEM SOLVING section in this manual. This section contains a checklist of possible problems and solutions that may save you the time and expense of an unnecessary service call.

If you cannot readily find the solution to the problem, please contact your nearest DACOR Authorized Service Representative. In the unlikely event they are unable to solve your problem to your satisfaction, please contact DACOR Customer Service.

Web site: [www.dacor.com](http://www.dacor.com)  
For a Dealer/Service: (800) 772-7778  
Corporate Phone: (800) 793-0093  
Fax: (626) 441-9632  
Business Hours: 7:30 A.M. to 4:00 P.M. Pacific Time

DACOR Customer Service  
1440 Bridge Gate Dr.  
Diamond Bar, CA 91765

Thank you for selecting DACOR for your home. We are dedicated to you and ensure that this appliance in your home will bring years of outstanding performance for your family and friends.

Sincerely,

S. Michael Joseph  
Chairman/CEO

<b>TABLE OF CONTENTS</b> .....	<b>1</b>
Purpose of this Manual .....	1
Product Registration .....	1
<b>IMPORTANT INSTRUCTIONS</b> .....	<b>1</b>
<b>GRILL OPERATION</b> .....	<b>2-5</b>
Safety .....	2
Liquid Propane Tanks.....	2
Grill/Cart Features.....	2-3
Install Liquid Propane Tank.....	3
Lighting Liquid Propane Grills .....	3
Lighting Natural Gas Grills .....	3-4
Manual Lighting.....	4
Canopy Mounted Temperature Gauge.....	4
Preheating Instructions .....	4
Grill Cooking .....	4
Smoker Cooking .....	4-5
Rotisserie Cooking.....	5
Side Burners .....	5
<b>CARE AND CLEANING</b> .....	<b>5-6</b>
Cleaning Tips .....	5
Exterior Surfaces .....	5
Interior Surfaces.....	6
<b>PROBLEM SOLVING</b> .....	<b>7-8</b>
Troubleshooting .....	7
Product Maintenance .....	8
If You Need Service .....	8
<b>PRODUCT WARRANTY</b> .....	<b>8</b>
What Is Covered .....	8
What Is Not Covered.....	8

## Important Instructions

### WARNINGS:

1. If the information in this manual is not followed exactly, a fire or explosion may result causing property damage, personal injury or death.
2. Do not store or use gasoline or other flammable liquids in the vicinity of the appliance.
3. If you smell gas:
  - Shut off gas to the appliance.
  - If odor continues, immediately phone your gas supplier.
  - Extinguish any open flame.
  - If you cannot reach your gas supplier, call the fire department.
  - Open Lid.
4. Installation and service must be performed by a qualified installer, service agency or the gas supplier.
5. This unit is for outdoor use only in a well-ventilated area. Not to be used in a building, garage or any other enclosed area.
6. Tested in accordance with ANSI Z21.58-1998, standard for outdoor cooking gas appliances and CAD/CGA 1.6-M98, standard for outdoor cooking gas appliances.
7. Check your local building codes for proper method of installation. In the absence of local codes, this unit should be installed in accordance with National Fuel Gas Code No. Z223.1 Current Issue and National Electrical Code ANSI/NFPA No. 70 Current Issue or the CAN/CGA - B149.1 Natural Gas Installation Code or CAN/CGA - B149.2 Propane Gas Installation Code and C22.1 Canadian Electrical Code Part 1.
8. **CALIFORNIA PROPOSITION 65 B**  
The burning of cooking fuel generates some by-products that are on the list of substances which are known by the State of California to cause cancer or reproductive harm. California law requires businesses to warn customers of potential exposure to such substances. To minimize exposure to these substances, always operate this unit to the instructions contained in this manual and provide good ventilation when cooking with gas.

### IMPORTANT:

1. Keep the area around the appliance clear and free from combustible materials, gasoline and other flammable liquids.
2. This outdoor gas cooking appliance is not intended to be installed in or on a recreational vehicle or boat.
3. Do not leave the grill unattended while cooking.
4. Do not place any items in front of the unit while in use. This could obstruct the proper flow of air needed for combustion and ventilation.
5. Keep the ventilation openings of the enclosure free and clear of obstructions and debris.
6. Always inspect the natural gas or LP gas hose assembly before each use of the appliance. If you see evidence of abrasion, wear, or a cut gas connection hose then immediately replace the hose prior to operation of the appliance.
7. Keep any electrical supply cords and the fuel gas supply lines away from heating surfaces.

## Purpose of This Manual

This **Use & Care Manual** is designed to enable you to properly operate and maintain your new grill. Please keep this manual handy for easy access and quick reference.

Additional information may be requested by e-mailing, writing or phoning the DACOR Customer Service Department. The address and phone number of this department are listed on the inside front cover of this manual.

## Product Registration

 Please enter the information requested in the spaces provided below. This information will be required in the unlikely event that a service call becomes necessary:

Model No. \_\_\_\_\_ Serial No. \_\_\_\_\_

Date Purchased \_\_\_\_\_ Date Installed \_\_\_\_\_

Purchased From \_\_\_\_\_

Address \_\_\_\_\_

Phone \_\_\_\_\_

**If you received a damaged product, immediately contact your dealer or builder. Do not install or use a damaged appliance.**

## Safety

### IMPORTANT:

Your Dacor grill is designed to be safe when installed properly. However, care must be used as these grills can produce very high temperatures which increases the potential for injury or accidents. We recommend you always follow the safety notes listed below.

### NOTES:

1. Carefully read this manual before using the grill, this will reduce the risk of injury due to fire or electric shock.
2. Proper installation is extremely important. Refer to the installation instructions included within the literature kit which shipped with your grill. Your installer should show you the location of the gas shut off valve and the electrical connection. You should also be familiar with the correct and easiest way to shut off these utilities in case of an emergency. Minimum clearances to combustible materials should always be observed. Reference the correct clearances in the installation instructions.
3. Repair and replacement of any parts within this appliance should be referred to an authorized Dacor service technician.
4. Children should never be allowed to sit, stand, or play around the grill at any time. Children should never be allowed to crawl inside the grill cart. Remember, when in use, the grill will get hot enough to cause severe burns.
5. Avoid the potential for grease fires by frequently cleaning the grease tray. Always allow the unit to completely cool down before removing the grease tray for cleaning.
6. Keep hands and fingers away from all edges of the canopy while in the raised position.
7. Never move the grill during cooking.
8. Always keep the canopy closed when moving the grill cart.
9. Spiders and insects can nest in the burners of this grill. This can obstruct the proper flow of gas into the burner and cause improper operation, fire hazard and potential damage to the unit. Periodically inspect the burners. If any of these symptoms occur, immediately refer to service or the troubleshooting section of this manual.
10. Your outdoor grill is equipped with a three-prong grounding plug to protect animals against shock hazard. This plug should be plugged directly into a properly grounded three-prong receptacle. Never cut or remove the grounding prong from this plug.
11. The grill canopy should be closed during the pre-heating period.

### 12. Gas Smells:

- If you smell gas when the unit is not in use, immediately shut off the gas at the main valve, open the canopy and call your local service agency to inspect the unit. Finding a leak is not a do-it-yourself process.
- If you smell gas when the unit is in use, immediately shut off the gas at the main valve, open the canopy, and dissipate for at least five minutes. Relight the burners and verify that they are operating properly. If the burners fail to light or are not functioning properly, shut off the main gas supply valve and call your local service agency for inspection.

13. Never block the vents located on the back of the grill or the opening at the rear of the canopy. Blocking any or all of these vents during cooking, will result in damage to the unit and may cause a fire or injury.

## Liquid Propane Tanks

1. Dacor LP model grills are set at the factory for LP tank installations. Use only the Dacor supplied regulator. DO NOT ATTEMPT FIELD CONVERSIONS. Approved field conversions from natural to LP or LP to natural will only be approved when completed by an authorized Dacor servicer.
2. Dacor grills are approved for a maximum LP tank capacity of 20 pounds (5 gallons). The tank must be constructed and marked in accordance with the specifications for LP-gas tanks of the U.S. Department of Transportation (DOT) or the National Standard of Canada, CAN/CSA-B339, tank, Spheres and Tubes of the Transportation of Dangerous Goods. To minimize the potential for fire or an explosion, the following precautions should be observed when using, filling, or storing an LP tank:
  - Never use a dented or rusty LP tank. If there is any question as to the soundness of the tank, have it checked by your LP supplier.
  - Never use a tank with a damaged or defective shut off valve.
  - Do not over fill the LP tank. Never fill the tank beyond eighty percent (80%) of its capacity. Overfilling will cause the pressure relief valve on the tank to vent excess gas vapor. This vapor is combustible and can ignite, causing a fire.
  - When transporting an LP tank, ensure it is in an upright position and away from any sources of high heat.
  - Do not store additional LP tanks inside the cart of the unit. Tanks must be stored outdoors in a well-ventilated area out of the direct sunlight and/or sources of high heat, and out of the reach of children.
  - LP tank supply systems must be arranged for vapor withdrawal.
  - LP tank used must include a collar to protect the tank valve.

### IMPORTANT:

1. For your safety, the gas supply must be turned off at the LP-gas supply tank when your grill is not in use.
2. The LP-gas supply cylinder must be disconnected when this barbecuing appliance is not in use.
3. If the appliance is to be stored indoors, the LP tank must be disconnected and removed from the appliance.
4. LP tanks not connected for use shall not be stored in the vicinity of this or any other appliance.
5. Detach and leave the tank outdoors if storing the unit indoors. These grills are for outdoor use only.
6. Check for leaks after every tank change.

## Grill Features

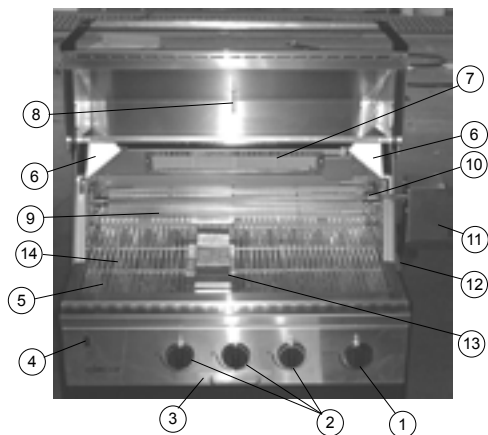

Built in Model EOG36 Features

### EOG36 Features:

1. Rotisserie control knob
2. Grill and Smoker control knobs
3. Drip retrieval tray
4. Interior lights on/off switch
5. Stainless steel grills
6. Halogen cooking lights
7. Infrared rotisserie burner (13,000 BTU)
8. Canopy mounted temperature gauge
9. Keep warm rack
10. Rotisserie Rod and forks
11. Rotisserie Motor
12. Rotisserie Bracket
13. Removable smoker box
14. Heat control channels

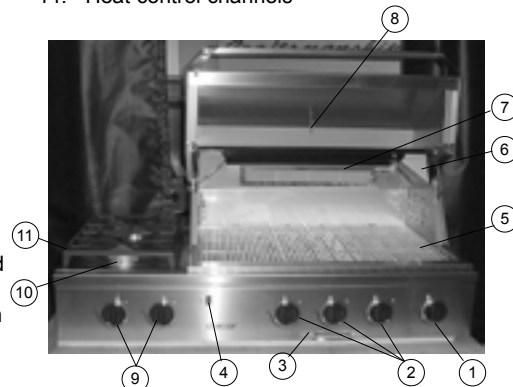

Built in Model EOG52 Features

### EOG52 Features:

1. Rotisserie control knob
2. Grill and Smoker control knobs
3. Drip retrieval tray
4. Interior lights on/off switch
5. Stainless steel grills
6. Halogen cooking lights
7. Infrared rotisserie burner (13,000 BTU)
8. Canopy mounted temperature gauge
9. Side burner control knobs

10. Side burners (2 - 18,000 BTU)
11. Burner grate

Keep warm rack (not shown)  
Rotisserie Rod and forks (not shown)  
Rotisserie Motor (not shown)  
Rotisserie Bracket (not shown)  
Removable smoker box (not shown)  
Heat control channels (not shown)

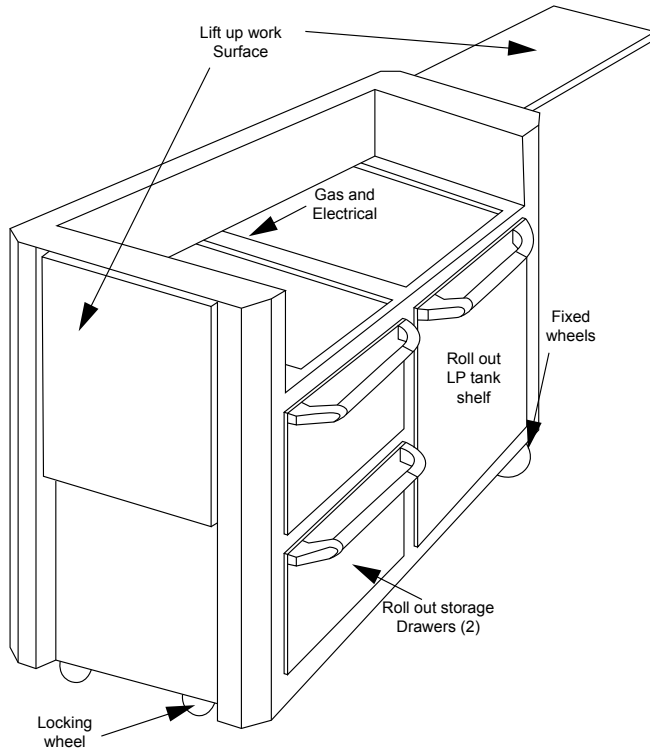

Freestanding Cart Model OGC36 Features

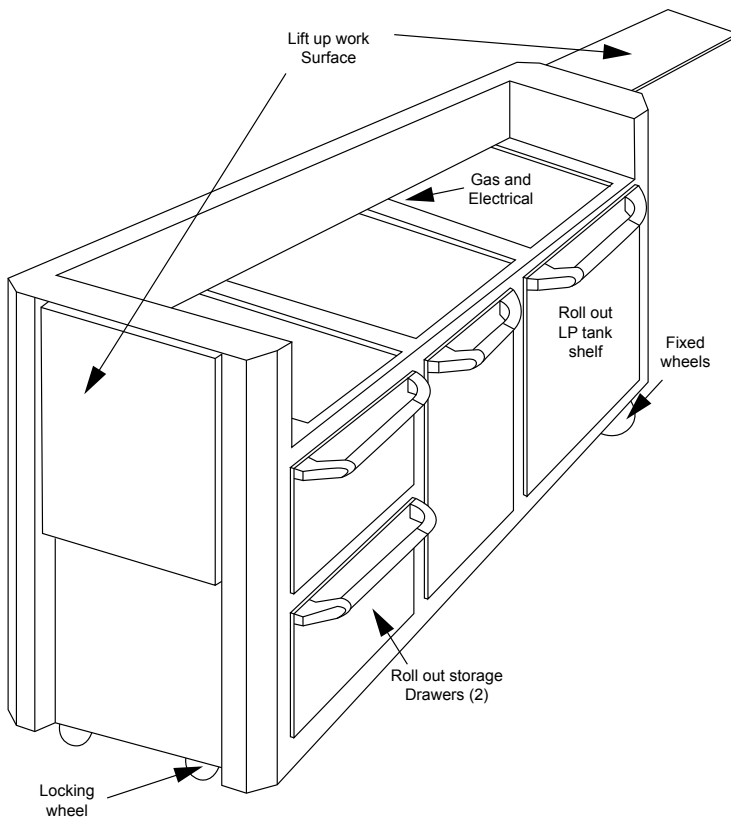

Freestanding Cart Model OGC52 Features

### Install Liquid Propane (LP) Tank

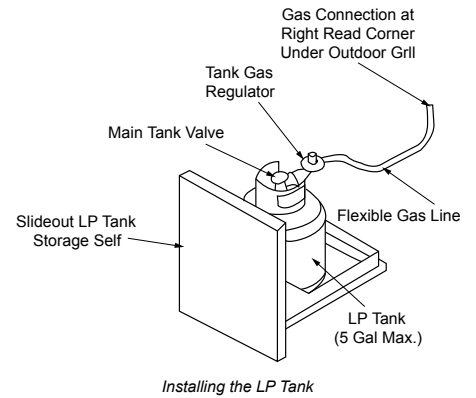

### Lighting Liquid Propane Grills

#### WARNING:

Open canopy before attempting to light the appliance. Failure to open the canopy could allow gas to accumulate which could cause an explosion.

#### NOTES:

1. Reference your installation instructions for proper LP gas line connections to the Dacor regulator and the "Main tank valve".
2. Once the tank is properly installed:
  - Open the canopy to full open position.
  - Turn on the main tank valve.
  - Light one grill burner at a time by pressing in on the control knob and turning it counter clockwise until you hear the clicking ignition sound. Your burner should ignite within 4 to 10 seconds.
  - Repeat the last step with all control locations.

### Lighting Natural Gas Grills

#### WARNING:

Open canopy before attempting to light the appliance. Failure to open the canopy could allow gas to accumulate which could cause an explosion.

#### NOTES:

1. Reference your installation instructions for proper natural gas line connections to the Dacor regulator.
2. Once you have confirmed that the electrical and gas are properly installed, begin the following processes:
  - Open the canopy to full open position.
  - Light one grill burner at a time by pressing in on the control knob and turning it counter clockwise until you hear the clicking ignition sound. Your burner should ignite within 4 to 10 seconds.
  - Repeat the last step with all control locations.

- If ignition does not immediately take place, turn the burner valve handle off, wait 5 minutes, and repeat the lighting procedure.

## Manual Lighting

### ⚠ WARNINGS:

FOR YOUR SAFETY FOLLOW THESE STEPS BEFORE ATTEMPTING A MANUAL LIGHTING PROCESS:

1. Turn all control knobs to OFF position.
2. Raise the canopy to its full open position.

### 📖 NOTES:

1. Remove all of the grills to access the heat control channels.
2. Find the hole in the front of the heat control channel located directly behind the front control panel.
3. Use the match holder provided or a long stem match to light the grill burners manually.
4. Push in on the control knob and turn counter-clockwise while inserting the burning match into the access hole in the heat control channel. This should immediately result in ignition. If you do not experience immediate ignition, turn the control back to the off position.
5. After waiting for 2 to 3 minutes, begin the process with step 4.
6. If you cannot achieve ignition after two attempts, turn off all gas to the product and immediately call your authorized Dacor servicer for a service call.

Access Hole for Manual Lighting

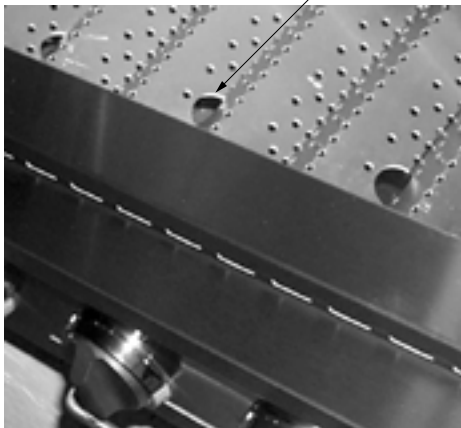

Access Hole for Manual Lighting

## Manual Lighting

### 📖 NOTES:

1. Your Dacor grill is equipped with a canopy mounted thermometer to assist you in various grill functions.
  - Preheating is an important part of proper grilling – preheat to approximately 225 degrees.
  - Smoking foods – heat to a temperature range from 225 to 300 degrees.

- Grilling all types of foods – vary temperatures as needed from 225 to 500 degrees.
2. We recommend these temperatures as approximations. For more detail please refer to your complimentary Dacor cooking guide. To receive your cooking guide, send your completed warranty card to Dacor's marketing department.

## Canopy Mounted Temp. Gauge

### 📖 NOTES:

1. Your Dacor grill is equipped with a canopy mounted thermometer to assist you in various grill functions.
  - Preheating is an important part of proper grilling – preheat to approximately 225 degrees.
  - Smoking foods – heat to a temperature range from 225 to 300 degrees.
  - Grilling all types of foods – vary temperatures as needed from 225 to 500 degrees.
2. We recommend these temperatures as approximations. For more detail please refer to your complimentary Dacor cooking guide. To receive your cooking guide, send your completed warranty card to Dacor's marketing department.

## Preheating Instructions

### 📖 NOTE:

When preheating, set burners on high. Following preheat, adjust burners to desired temperature setting.

In order for the U- burners and burner box to remain clean, the gas burners and the flame spreaders have to be hot enough to vaporize fats/oils/marinades as they drip upon them. Without a proper preheat, these materials will collect on both the flame spreader and the burner tubes resulting in partial or total loss of ignition or a decrease in burner performance.

Always light every burner to generate maximum heat output and to assure even heat distribution. Using only one or two burners can eventually result in a buildup of unwanted material and could affect performance.

### 📖 NOTE:

In colder climates the infrared burner may have to be used in order to achieve the suggested preheat temperature of 500F.

Regardless of what you are barbecuing, use every burner. This assures even heat distribution and also improves grease/fat management. Using only one or two burners will eventually result in an unwanted buildup of material that might inhibit reliable performance.

After using the barbecue, allow it to continue heating an additional five minutes. This allows materials to move to the grease tray and away from the burner area. This assures clean burners and a healthy ignition system.

## Grill Cooking

### 📖 NOTES:

1. Advanced preparation:
  - Bring all food items to be grilled to thawed temperature.
  - Check to make sure the drip retrieval tray is in position.
  - Preheat the grill with the canopy closed to a minimum of 225 degrees or the applicable cooking temperature for the food you are preparing.
  - Refer to the Dacor cooking guide for preheat/cooking food temperatures and style of cooking recommended.
2. Begin the cooking process:
  - Once you have achieved the appropriate temperature for your chosen recipe, place the food product on the grill and begin the timing process.
  - Refer to your Dacor cooking guide for approximate times for all types of grilled foods.
3. After completion of cooking:
  - Remove the food to serve and close the canopy for a safer environment. (Refer to the Care and Cleaning section of this manual for further instructions.)

## Smoker Cooking

### ⚠ WARNINGS:

1. Smoker cooking is done with the canopy in the down position. Smoke will be exhausting through the grill vents. Do not block vents. Blocking vents will damage the unit and may cause fire or injury.
2. Smoker wood chips are soaked with liquids which create steam and smoke while barbecuing. Proceed with caution during cooking. This steam can be very hot and dangerous. (Refer to the cooking guide)
3. Frequently, the smoker box will need to be refilled during cooking. It will be extremely hot. Exercise caution during this process. Steam and hot metal surfaces can cause personal injuries and possible fire.

### 📖 NOTES:

1. Smoker cooking enhances the flavors of food during grilling or rotisserie cooking.
2. Your Dacor smoker box is a removable accessory that is shipped with your originally purchased grill product.
3. The smoker should be filled with your choice of wood chips. For your convenience, please refer to your Dacor grill cooking guide for a chart of wood types, characteristics, and foods to go with each type of wood chip.

4. Once you have prepared the wood and smoker box for use, while the grill is still cool, select a direct or indirect cooking location, then place the smoker box appropriately. (Refer to the grill cooking guide for smoker direct vs. indirect cooking.)
5. To place the smoker box correctly
  - Determine desired smoker location.
  - Remove one small grill and the even heat channel. (The grills and even heat channels may be moved to create a smoker opening anywhere across the full width of the unit.)
  - Place smoker in the opening.
6. Turn on the burner to maximum (HI) temperature. Leave the burner on high until the chips begin smoking. Then turn the heat down where the chips don't dry out or flame up.
7. Recipes with long time duration will require the addition of wood and liquid to the smoker box. Remember, every additional time you open the grill canopy and smoker box, you will extend your recipe cooking times.
8. Clean up should occur only after cool down. Do not leave the smoker box and its contents inside the grill during HI heat self cleaning.
9. A cool smoker box and the residue can be removed safely for cleaning. Dump the cool wood remnants and wash the stainless steel smoker box with warm water and dish soap. Rinse well and dry the box. Do not dump the remnants until cool.

### Rotisserie Cooking

#### WARNING:

This unit is equipped with a 3-prong grounding plug for your protection against shock hazard and should be plugged directly into a properly grounded receptacle. Do not cut or remove the grounding prong from this plug. Do not allow the rotisserie electrical cord to touch any heated surface of your grill.

#### CAUTION:

1. Cooking with the rotisserie burner is not recommended during high wind.
2. If any flame is blown out during windy conditions and does not automatically re-ignite within 5 to 7 seconds, turn off the control and attempt a new ignition until you hear the constant clicking stop and you see flame ignition.

#### NOTES:

1. Rotisserie cooking utilizes the intense searing heat of the infrared burner and constant rotisserie rod rotation to cook many different types of meat. (Please Refer to the rotisserie section of your Dacor grill cooking guide for charts and recipes.)

2. Rotisserie burner operation:
  - Rotisserie burner requires no pre-heating.
  - Rotisserie burner can be used in conjunction with grill burners and smoker box.
  - Push control knob and rotate 1/4 turn to the left (igniters will spark). Push knob and hold (approximately 30 seconds) until burner stays lit. If ignition does not immediately take place, turn burner knob off, wait 5 minutes, and repeat lighting procedure.
3. Rotisserie Motor and Rotisserie Rod Prepare the grill for rotisserie cooking by following these steps:
  - Install the motor mounting bracket and motor by slipping the edge of the bracket down into the slot at the right side edge of the grill frame. (as shown below)
  - Plug the motor power cord into 120 VAC grounded receptacle. Keep the cord away from all heated surfaces.
  - Load your menu items on the rotisserie rod. (Recommended loading procedures are listed in your Dacor grill cooking guide.)
  - Mount your loaded rotisserie rod into the drive location on the rotisserie motor and into secondary mounting support on the left side of the grill.
  - Double check all rotisserie forks and locking screws for tightness to assure items will not move during rotation.
  - Turn on the motor and observe several rotations to confirm the food is stable, then close the canopy completely and you are cooking.

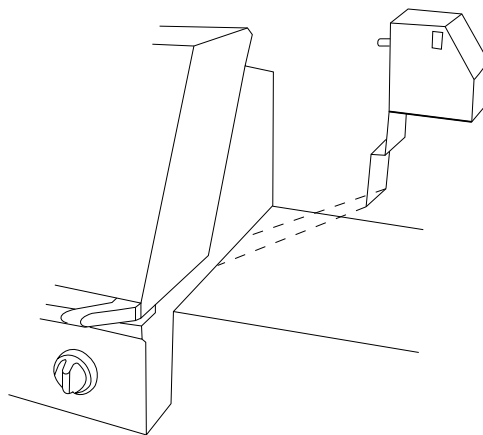

Rotisserie Installation

### Side Burners (Select Models Only)

#### IMPORTANT:

Do not place the burner cover over the burners while hot. Excessive heat contact with the cover may cause permanent discoloration.

#### NOTES:

1. Largest recommended pot for these burners is 14 inches in diameter. Larger pots may contact the grill canopy during opening and closing.
2. Automatic re-ignition systems will ignite an extinguished flame.
3. Do not operate the side burner in windy conditions.
4. The porcelain burner grate is durable, however continuous sliding of pots can remove surface material.
5. A stainless steel side burner cover is made to cover the burner grate and burners when not in use.

### Cleaning Tips

#### WARNING:

To avoid electric shock or burns, turn off all controls and ensure the grill is cool before cleaning. Do not store any type of cleaning products around the grill.

#### NOTES:

1. Read and follow the CARE AND CLEANING INSTRUCTIONS to ensure that proper grill operation and appearance will be maintained throughout the lifetime of the product. Several materials and finishes are used in the grill. Each material and finish must be properly cleaned according to the following recommendations. Failure to follow these recommendations may result in permanent damage to the grill.
2. To keep the grill looking it's best, clean it after every use.
3. Use the mildest cleaners or procedure available to perform the cleaning operation. Do not use commercial cleaners to clean any part of the grill.
4. Use only a sponge, soft cloth, fibrous or plastic brush and nylon pad for cleaning. Avoid the use of abrasive cleaners such as steel wool.
5. Always dry components completely before using the grill.
6. The use of brand names is intended only to indicate a type of cleaning agent or cleaning implement. All products listed by name must be used in accordance with the manufacturer's recommendations. Use of a brand name does not constitute an endorsement, nor does omission of a particular brand imply that a product is inferior.

## Exterior Surfaces

### IMPORTANT:

1. Turn the knobs to the "OFF" position prior to removing them from the valve stems.
2. The grill should never be operated without the knobs in place.
3. Do not soak the knobs in water or place them in the dishwasher.
4. Do not expose the knobs to direct flame, hot utensils or other sources of heat.
5. Do not use abrasive or corrosive cleaners or applicators, as these could cause permanent damage.

### NOTE:

Cleaning stainless steel varies with each part of the grill. To assist you, please refer to the list below for the suggested cleaning procedures:

1. **Stainless Steel (canopy, chassis)**
  - Wipe with the grain
  - Non-abrasive cleaners or
  - Mild abrasive cleaners
  - For stubborn areas, use the Dacor Cooktop Cream supplied with the grill
  - "Liberally apply the cleaner to a wet sponge. For best cleaning results thoroughly rinse off all residue."
2. **Porcelain (black upper back wall)**
  - Non-abrasive cleaners
  - Mild abrasive cleaners
3. **Brass Burner Caps**
  - Mild abrasive cleaners
  - Do not place burner caps in the dishwasher for cleaning.
4. **Plastic (knobs)**
  - Non-abrasive cleaners. (warm water with dish soap)

## Interior Surfaces

### IMPORTANT:

To assist in the removal of the halogen light lens Dacor has included a pry stick. Gently slip the pry stick under the edge of the glass and pry away until the glass lifts. Remove the remaining distance by hand.

### NOTES:

To assist you, please refer to the list below for the suggested cleaning procedures:

1. **Stainless Steel (grills, heat control channels, burner box)**
  - Mild abrasive cleaners
  - De-greasers (such as 409)
  - Abrasive cleaners (limited applications)
  - Dacor Cooktop Creme and wet sponge
2. **Stainless Steel (u-shape burners)**
  - Mild abrasive cleaners
  - Abrasive cleaners (limited applications)
3. **Glass (light lens)**
  - Non-abrasive cleaners
  - Glass cleaners are acceptable
  - Warm soapy water



## Troubleshooting

Unnecessary service calls may be expensive, frustrating and time consuming. Before you call for service, please review the potential problems, possible causes and remedies shown in the table below.

Problem	Possible Cause	Remedy
1. Nothing works.*	Grill is not connected to electrical power.	Have grill connected to the proper electrical supply by a qualified electrician or appliance installer.
	Power supply is not energized.	Check circuit breaker, wiring, fuses, plugs, etc.
2. Igniters do not spark.*	Circuit breaker is tripped.	Reset circuit breaker.
	House fuse is blown.	Replace house fuse.
3. Sparking but no flame.	Gas shut-off valve is in "off" position.	Turn shut-off valve to "on" position.
	Ports on U-burner are clogged or dirty.	Brush U-burner with a steel brush and clear blockage with a toothpick or metal object (straightened paper clip, needle, or wire).
4. Burners ignite but flame is extremely large, distorted or yellow.	Ports on U-burner are clogged or dirty.	Brush U-burner with a steel brush and clear blockage with a toothpick or metal object (straightened paper clip, needle, or wire).
	Grill is being operated on wrong type of gas.	Ensure that the type of grill matches the gas supply (natural gas or LP).
	Regulator is not installed, is faulty, or is set for the wrong type of gas.	Check installation, replace regulator, or set regulator for proper gas type.
5. Burner flame goes out at low setting.	Low gas pressure.	Contact gas company, have incoming gas pressure tested.
	Air intake holes under the control panel are obstructed.	Remove obstruction.
	Incorrect installation.	Check installation dimensions against installation instructions.
6. Igniters spark continuously after flame ignition.	Ports on U-burner are clogged or dirty at ignition location.	Brush U-burner with a steel brush and clear blockage with a toothpick or metal object (straightened paper clip, needle, or wire).
	Power supply polarity is reversed.	Have polarity corrected.
	Igniters are wet or dirty.	Dry igniters or clean igniters with a metal brush to remove any residue.
	Low burner flame.	Contact gas company, have incoming gas pressure tested.

*Troubleshooting Guide*

\* **The grill burners can be manually ignited with a match or the hand spark ignitor supplied with the unit. (Refer to Manual Lighting section on page 6.)**

## Product Maintenance

No maintenance, other than the **CARE AND CLEANING INSTRUCTIONS** identified in this Use & Care Manual, should be attempted by the owner/operator. All other maintenance and service must be performed by a qualified appliance technician.

## If You Need Service...

First, review the recommended checks listed in the preceding **Troubleshooting Guide**. Then, be certain that the appliance has been installed properly and is being operated correctly. Familiarize yourself with the warranty terms and conditions listed in the **PRODUCT WARRANTY** section on the inside back cover.

If the above checks have been completed and the problem has not yet been remedied, call your local authorized DACOR service representative. Your dealer can normally provide the name and telephone number of the nearest service company.

DACOR works diligently to ensure your satisfaction when service is necessary. However, if you are not completely satisfied with the service provided, contact the company that performed the service and express why you are not pleased. Normally, they will be willing and able to resolve the problem.

If the service agency is not able to respond effectively, call or write the DACOR Customer Service Department. The phone number and address of this department are listed on the inside front cover of this manual. Please include your telephone number if you choose to write. We will then do our utmost to assure your happiness and satisfaction.

## What is Covered

CERTIFICATE OF WARRANTIES  
DACOR EPICURE™ GRILLS

### WITHIN THE FIFTY STATES OF THE U.S.A., THE DISTRICT OF COLUMBIA AND CANADA\*: ONE-YEAR FULL WARRANTY

If your DACOR product fails to function within one year of the original date of purchase, due to a defect in material or workmanship, DACOR will remedy the defect without charge to you or subsequent users. The owner must provide proof of purchase, upon request, and have the appliance accessible for service.

FIVE YEAR LIMITED WARRANTY  
Rotisserie burner

### LIFETIME WARRANTY

All stainless steel components, including grill and grill burners, are warranted against rust through.

## OUTSIDE THE FIFTY STATES OF THE U.S.A., THE DISTRICT OF COLUMBIA AND CANADA:

### LIMITED FIRST YEAR WARRANTY

If your DACOR product fails to function within one year of the original date of purchase, due to a defect in material or workmanship, DACOR will furnish a new part, F.O.B. factory, to replace the defective part. All delivery, installation and labor costs are the responsibility of the purchaser. The owner must provide proof of purchase, upon request, and have the appliance accessible for service.

## What is Not Covered

- Failure of the product caused by faulty installation, improper usage, or neglect of required maintenance.
- Service calls to educate the customer in the proper use and care of the product.
- Failure of the product when used for commercial, business, rental or any application other than for residential consumer use.
- Replacement of house fuses or fuse boxes, or resetting of circuit breakers.
- Damage to the product caused by accident, fire, flood or other acts of God.
- Breakage, discoloration or damage to glass, metal surfaces, plastic components, trim, paint, or other cosmetic finish, caused by improper usage or care, abuse, or neglect.

THE REMEDIES PROVIDED FOR IN THE ABOVE EXPRESS WARRANTIES ARE THE SOLE AND EXCLUSIVE REMEDIES. THEREFORE, NO OTHER EXPRESS WARRANTIES ARE MADE, AND OUTSIDE THE FIFTY STATES OF THE UNITED STATES, THE DISTRICT OF COLUMBIA AND CANADA, ALL IMPLIED WARRANTIES, INCLUDING BUT NOT LIMITED TO, ANY IMPLIED WARRANTY OF MERCHANTABILITY OR FITNESS FOR A PARTICULAR USE OR PURPOSE, ARE LIMITED IN DURATION TO ONE YEAR FROM THE DATE OF ORIGINAL PURCHASE. IN NO EVENT SHALL DACOR BE LIABLE FOR INCIDENTAL EXPENSE OR CONSEQUENTIAL DAMAGES. NO WARRANTIES, EXPRESS OR IMPLIED, ARE MADE TO ANY BUYER FOR RESALE.

Some states do not allow limitations on how long an implied warranty lasts, or do not allow the exclusion or limitation of inconsequential damages, so the above limitations or exclusions may not apply to you. This warranty gives you specific legal rights, and you may also have other rights that vary from state to state.

fold here

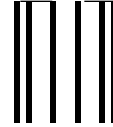

NO POSTAGE  
NECESSARY  
IF MAILED  
IN THE  
UNITED STATES

**BUSINESS REPLY MAIL**  
FIRST-CLASS MAIL      PERMIT NO. 4507      DIAMOND BAR CA

POSTAGE WILL BE PAID BY ADDRESSEE

**ATTN: WARRANTY PROCESSING DEPT  
DACOR  
1440 BRIDGEGATE DR STE 200  
PO BOX 6532  
DIAMOND BAR CA 91765-9861**

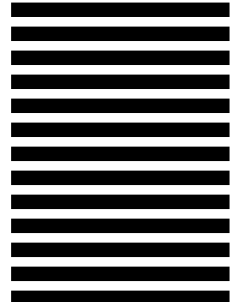



Please visit [www.dacor.com](http://www.dacor.com) to activate your warranty online.

# WARRANTY INFORMATION



### IMPORTANT:

Your warranty for this product **CANNOT BE ACTIVATED** until this form has been returned to Dacor. If you have purchased more than one Dacor product, Please return all forms in one envelope.

Please rest assured that under no conditions will Dacor sell your name or any of the information on this form for mailing list purposes. We are very grateful that you have chosen Dacor products for your home and do not consider the sale of such information to be a proper way of expressing our gratitude!

(Please Print or Type)

Owner's Name: \_\_\_\_\_  
Last First Middle

Street: \_\_\_\_\_

City: \_\_\_\_\_ State: \_\_\_\_\_ Zip: \_\_\_\_\_

Purchase Date: \_\_\_\_\_ Email: \_\_\_\_\_ Telephone: \_\_\_\_\_

Dealer: \_\_\_\_\_

City: \_\_\_\_\_ State: \_\_\_\_\_ Zip: \_\_\_\_\_

Your willingness to take a few seconds to fill in the section below will be sincerely appreciated. Thank you.

1. How were you **first** exposed to Dacor products? (Please check one only.)

- A. T.V. Cooking Show
- B. Magazine
- C. Appliance Dealer Showroom
- D. Kitchen Dealer Showroom
- E. Home Show
- F. Builder
- G. Architect/Designer
- H. Another Dacor Owner
- I. Model Home
- J. Other \_\_\_\_\_

2. Where did you buy your Dacor appliances?

- A. Appliance Dealer
- B. Kitchen Dealer
- C. Builder Supplier
- D. Builder
- E. Other \_\_\_\_\_

3. For what purpose was the product purchased?

- A. Replacement **only**
- B. Part of a Remodeled
- C. New Home
- D. Other \_\_\_\_\_

4. What is your household income?

- A. Under \$75,000
- B. \$75,000 – \$100,000
- C. \$100,000 – \$150,000
- D. \$150,000 – \$200,000
- E. \$200,000 – \$250,000
- F. Over \$250,000

5. What other brands of appliances do you have in your kitchen?

- A. Cooktop \_\_\_\_\_
- B. Oven \_\_\_\_\_
- C. Dishwasher \_\_\_\_\_
- D. Refrigerator \_\_\_\_\_

6. Would you buy or recommend another Dacor product?

- Yes
- No

Comments: \_\_\_\_\_

Thank you very much for your assistance. The information you have provided will be extremely valuable in helping us plan for the future and giving you the support you deserve.

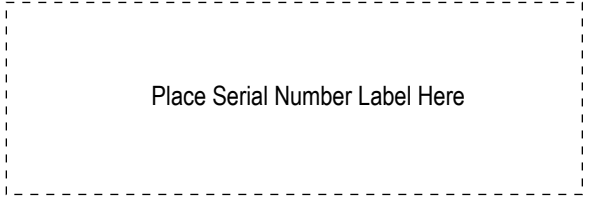

cut here

cut here

## Free Manuals Download Website

<http://myh66.com>

<http://usermanuals.us>

<http://www.somanuals.com>

<http://www.4manuals.cc>

<http://www.manual-lib.com>

<http://www.404manual.com>

<http://www.luxmanual.com>

<http://aubethermostatmanual.com>

Golf course search by state

<http://golfingnear.com>

Email search by domain

<http://emailbydomain.com>

Auto manuals search

<http://auto.somanuals.com>

TV manuals search

<http://tv.somanuals.com>