

3 Door Panel Overlay Installation Guide

IF36 Series 3-Door Refrigerators

Top Panels:	<u>Width</u>	<u>Height</u> (in inches)
1/4" or 3/8" backer *	17 13/16*	42 1/16

* Recessed backer option: The backer material is exposed along the handle side of both upper doors. The 17 13/16" width dimension provides both 1/4" and 3/8" backers with a 3/16" recesses from the backer edge to the panel edge along the handle side. See page 2. The exposed edge of the backer material can be covered with wood veneer, melamine or painted to match either the panel or refrigerator color. Handle mounting screws will retain panels to the hinge side of the panel frame. A full dimension backer without any recess would measure 17 15/16". For a full dimension backer, read and understand the information and notes for 1/4" veneered panels.

Frameless Overlay (panel covers metal trim)	18 1/8	42 1/4
Framed Inlay (panel does not cover metal trim)	17 13/16	41 5/8
Framed Veneer **	18 **	42 1/16

** Note: an additional instruction specific to a 1/4" veneered backer. The metal frame is designed to fit a panel 17 15/16" wide. Cutting an 18" panel allows for a 1/4" space between upper panels and covers the 1/16" edge of the aluminum trim at both ends of the handle side of the panel. Detailed filing is needed at the top and bottom of the handle side of both upper doors for the panel to fit. TEST FIT BEFORE AND DURING FILING. Carefully file a small notch approximate 1/16" x 7/32" at the bottom of the handle side of the panel to allow the panel bottom to fit into the top and bottom aluminum trim. TEST FIT BEFORE AND DURING FILING. Carefully file a similar 1/16" x 7/32" notch at the top to allow the top trim to fit over the top of the panel.

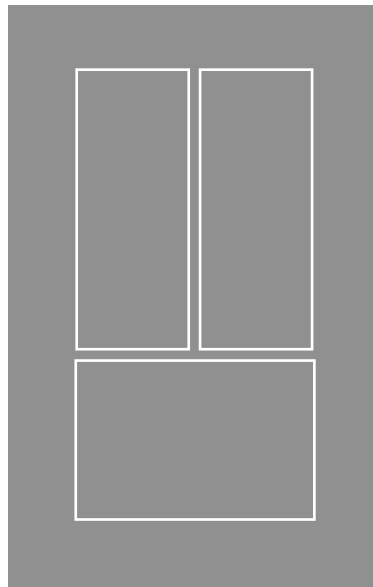

Bottom Panel:	<u>Width</u>	<u>Height</u> (in inches)
1/4" or 3/8" backer material	36 3/16	23 13/16
Frameless Overlay (panel covers metal trim)	36 1/2	24
Framed Inlay (panel does not cover metal trim)	35 3/4	23 3/8
Framed Veneer	36 3/16	23 13/16

No backer instructions: Mill panel or frame material to include a 1/4" x 3/16" tongue on the trim edge. Use appropriate inlay or overlay dimension to construct panels with the proper outside dimensions. See illustrations on page 4.

Note: Longer screws are needed to attach the handle mounting posts when overlay panels are applied. For ease and availability, consider using Kreg pocket screws: 2-1/2", #8 Coarse, Washer-Head. Pre-drill panels with a 5/32" pilot hole. DO NOT pre-drill the refrigerator metal door. DO NOT over tighten.

IF-36 Refrigerator 3-Door Panel Overlay Installation Guide

3/8" Backer Edge Details:

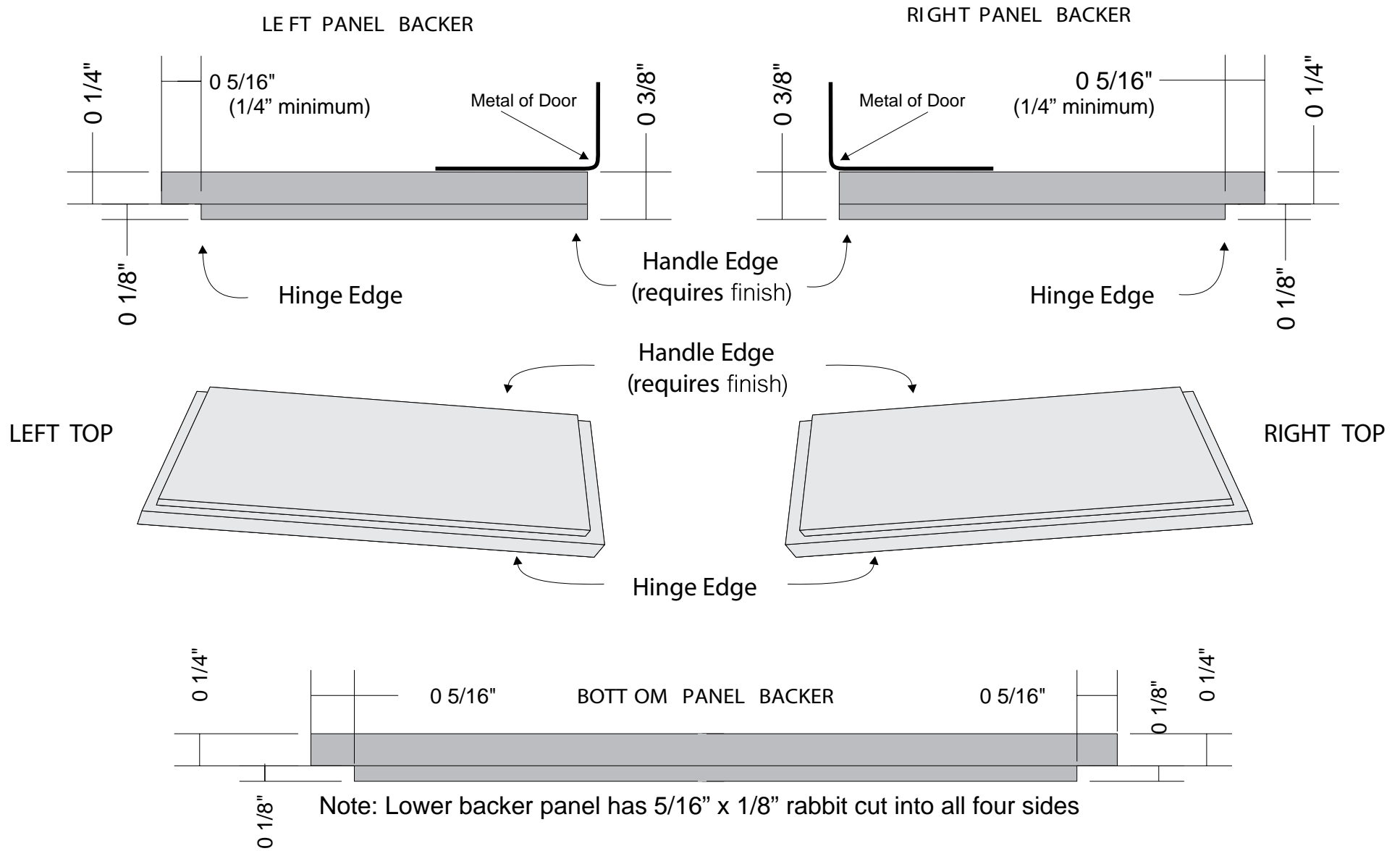

IF-36 Refrigerator 3-Door Panel Overlay Installation Guide

Cross Section of Overlay and Inlay Panels:

3/8" and 1/4" Backers
Left Panel Shown

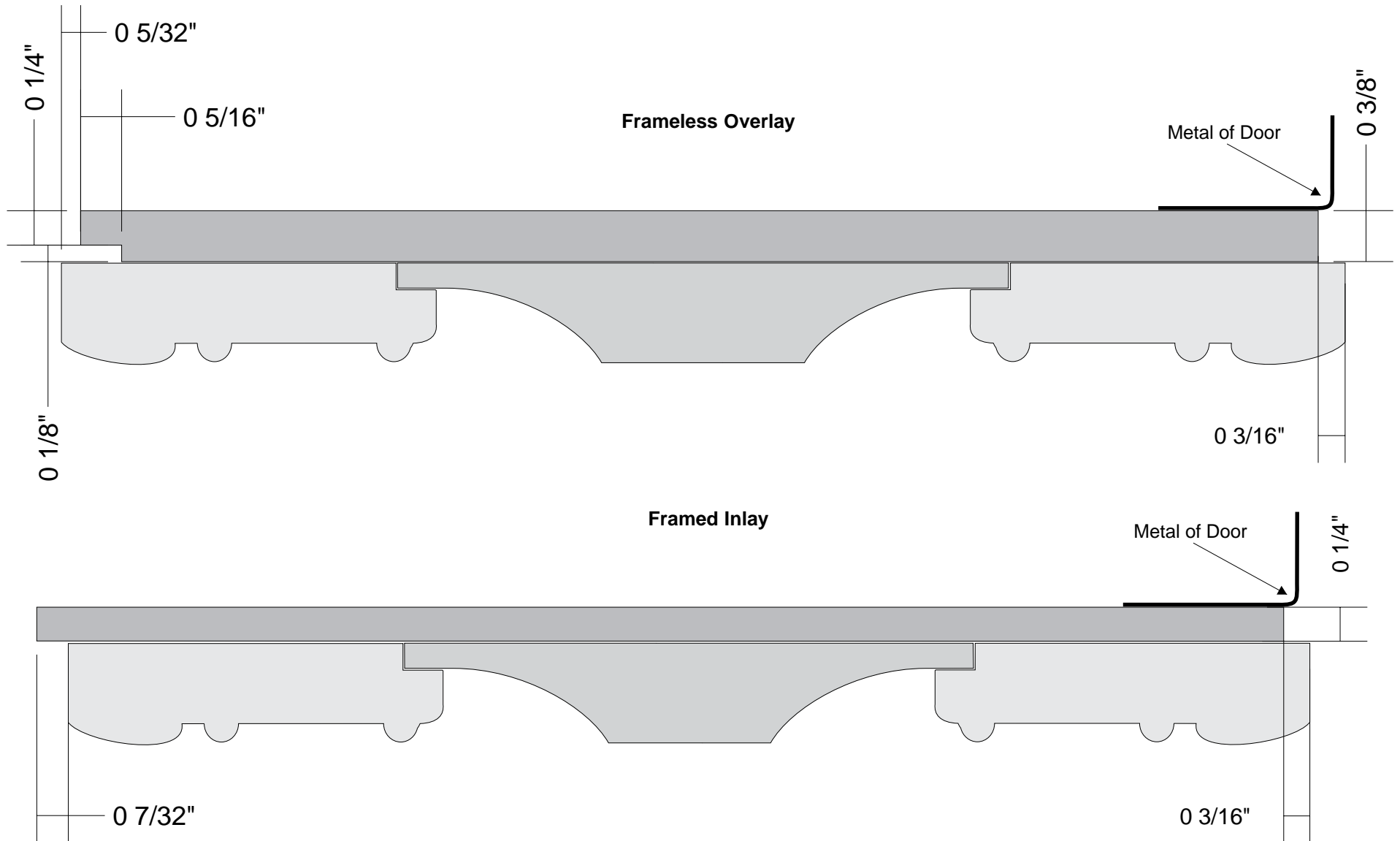

IF-36 Refrigerator 3-Door Panel Overlay Installation Guide

Panel With No Backer

Top View Sectional
Left Panel Only

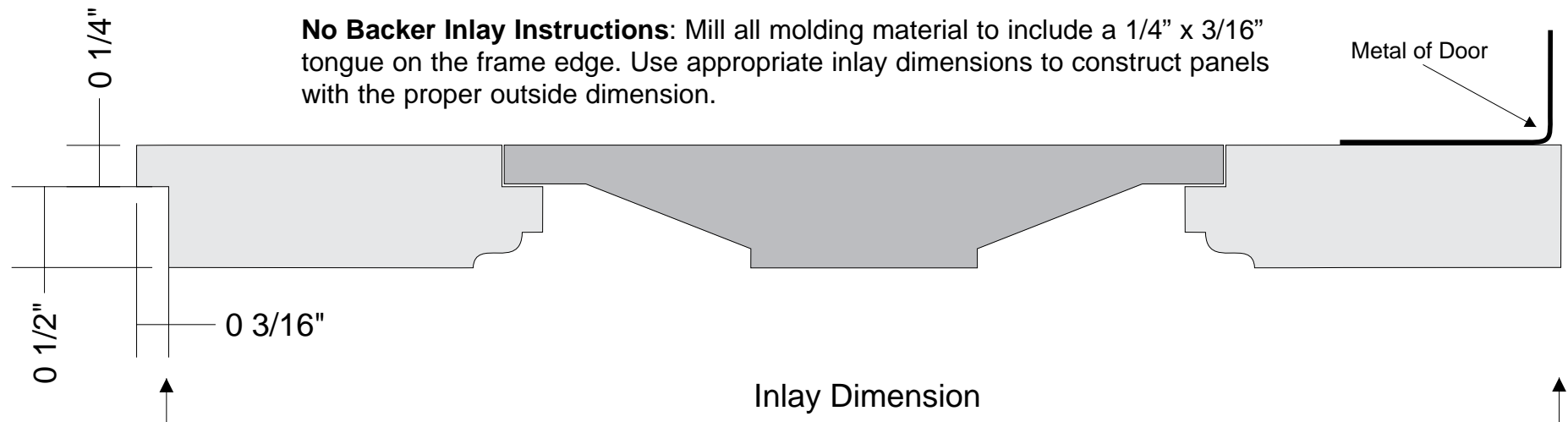
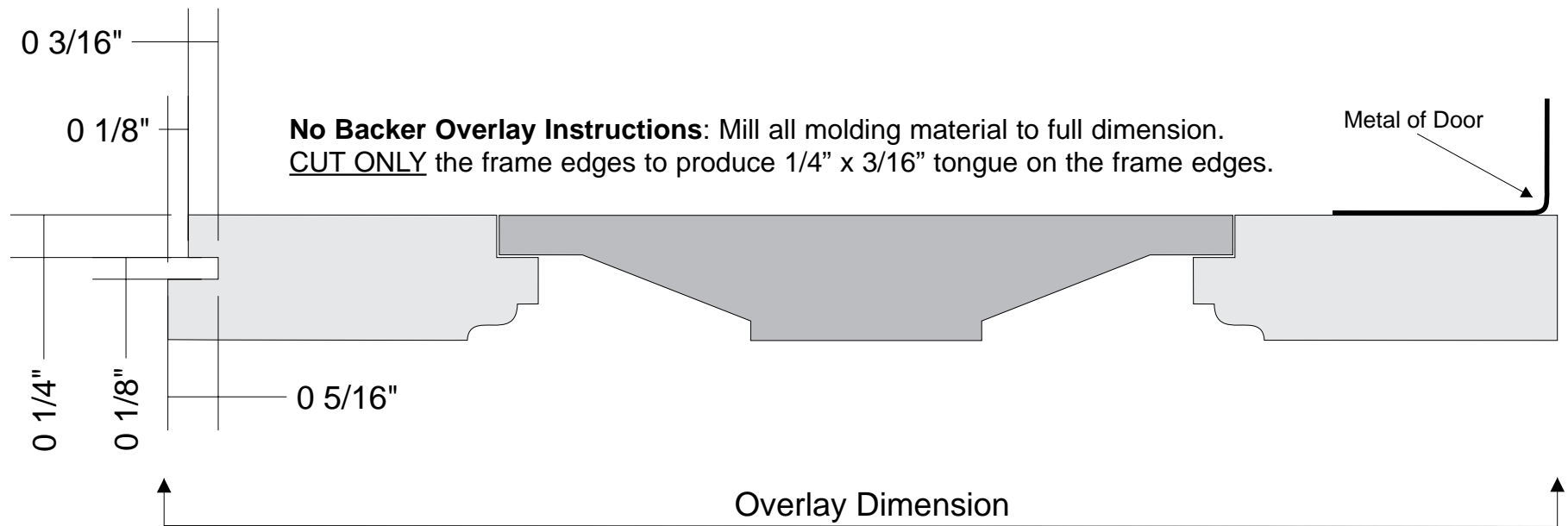

Free Manuals Download Website

<http://myh66.com>

<http://usermanuals.us>

<http://www.somanuals.com>

<http://www.4manuals.cc>

<http://www.manual-lib.com>

<http://www.404manual.com>

<http://www.luxmanual.com>

<http://aubethermostatmanual.com>

Golf course search by state

<http://golfingnear.com>

Email search by domain

<http://emailbydomain.com>

Auto manuals search

<http://auto.somanuals.com>

TV manuals search

<http://tv.somanuals.com>