

DAEWOO

Service Manual
XGA COLOR MONITOR
Model : L510B1

DAEWOO ELECTRONICS CO., LTD.

<http://svc.dwe.co.kr>

September, 2001

CONTENTS

SAFETY PRECAUTIONS	1
GENERAL SAFETY INFORMATION	2
SERVICING PRECAUTIONS	3
TECHNICAL INFORMATION	6
GENERAL INFORMATION	7
PIN CONNECTOR	8
CAUTIONS FOR ADJUSTMENT AND REPAIR	8
OPERATION & ADJUSTMENT	9
ALIGNMENT PROCEDURE	14
TROUBLESHOOTING HINTS	15
BLOCK DIAGRAM	22
PCB LAYOUT	23
SCHEMATIC DIAGRAM	27
EXPLODED VIEW & MECHANICAL PARTS LIST	29
INFORMATION OF PART DESCRIPTION	30
ELECTRICAL PARTS LIST	31

SAFETY PRECAUTIONS

CAUTION: No modifications of any circuits should be attempted. Service work should be performed only after you are thoroughly familiar with all of the following safety checks and servicing guidelines.

◆ Safety Check

Care should be taken while servicing the inverter that generates the high voltage to lighten CCFL of the LCD panel.

◆ Fire & Shock Hazard

- Insert an isolation transformer between the analog color display and AC power line before servicing the chassis.
- When servicing, pay close attention to the original lead dress especially in the high voltage circuit area; if a short circuit is found, replace all parts which have been overheated as a result of the short circuit.
- All the protective devices must be reinstalled per original design.
- Soldering must be inspected for possible cold solder points, frayed leads, damaged insulation, solder splashes or sharp solder points. Be certain to remove all foreign materials.

GENERAL SAFETY INFORMATION

◆ Terms in the manual

CAUTION Statements identify conditions or practices that could result in damage to the equipment or other property.

WARNING Statements identify conditions or practices that could result in personal injury or loss of life.

◆ Terms as marked on equipment

CAUTION Statements indicate a personal injury hazard not immediately accessible as one reads the marking or a hazard which is properly included on the equipment itself.

WARNING Statements are clearly concerning indicated personal injury hazards.

◆ Symbols in the manual

The symbols indicate where applicable cautionary or other information is to be found.

◆ Symbols as marked on equipment

Protective GROUND terminal



◆ High Voltage Warning And Critical Component Warning Label

The following warning label is on the inverter isolation case.

SERVICING PRECAUTIONS

CAUTION: Before servicing instruments covered by this service manual, its supplements, and addendum, please read and follow the SAFETY PRECAUTIONS of this manual.

NOTE: If unforeseen circumstances create conflict between the following servicing precautions and any of the safety precautions on page 1 of this manual, always follow the safety precautions. Remember: Safety First.

◆ General Servicing Precautions

1. Always unplug the AC power cord from the AC power source before:
 - a. Removing or reinstalling any component, circuit board, module, or any other instrument assembly.
 - b. Disconnecting or reconnecting any electrical plug or other electrical connection.
 - c. Connecting a test substitute in parallel with an electrolytic capacitor in the instrument.

CAUTION: A wrong part substitution or incorrect polarity installation of electrolytic capacitors may result in a explosion.

- d. Discharging the picture tube anode.
2. Test high voltage only by measuring it with an appropriate high voltage meter or other voltage measuring device (DVM, FETVOM. etc.) equipped with a suitable high voltage probe. Do not test high voltage by “drawing an arc”.
3. Discharge the picture tube anode only by: (a) first connecting one end of an insulated clip lead to the degaussing or line grounding system shield at the point where the picture tube socket ground lead is connected, and then (b) touching the other end of the insulated clip lead to the picture tube anode button, using an insulating handle to avoid personal contact with high voltage.
4. Do not any spray chemicals on or near this instrument, or any of its assemblies.
5. Unless otherwise specified in this service manual, only clean electrical contacts by applying the following mixture to the contacts with a pipe cleaner, cotton-tipped stick, or comparable nonabrasive applicator: 10% (by volume) Aceton and 90% (by volume) isopropyl alcohol (90%-99% strength).

CAUTION: This is a flammable mixture. Unless specified in this service manual, lubrication of contacts is not required.

6. Do not apply AC power to this instrument and/or any other of its electrical assemblies unless all the solid-state device heat sinks are correctly installed.
7. Always connect the test instrument ground lead to the appropriate instrument chassis ground before connecting the test instrument positive lead. Always remove the test instrument ground lead last.
8. Only use the test fixtures specified in this service manual with this instrument.

◆ Electrostatically Sensitive (ES) Devices

Some semiconductor (solid state) devices can be damaged easily by static electricity. Such components are commonly called Electrostatically Sensitive (ES) Devices. The typical examples of ES devices are integrated circuits, some field-effect transistors, and semiconductor “chip” components. The following techniques should be used to help reduce the incidence of component damage caused by static electricity.

1. Immediately before handling any semiconductor component or semiconductor-equipped assembly, wipe off any electrostatic charge on your body by touching any known earth ground. Alternatively, obtain and wear a commercially available discharging wrist strap device which should be removed for potential shock reasons prior to applying power to the unit under testing conditions.
2. After removing the electrical assembly equipped with ES devices, place the assembly on a conductive surface such as aluminum foil to prevent electrostatic charge buildup or exposure to the assembly.
3. Only use a grounded-tip soldering iron to solder or unsolder ES devices.
4. Only use an anti-static type solder removal device. Some solder removal devices not classified as “anti-static” can generate enough electrical charges to damage ES devices.
5. Do not use freon-propelled chemicals. These can generate enough electrical charges to damage ES devices.
6. Do not remove a replacement ES device from its protective package until immediately before you are ready to install it. (Most replacement ES devices are packaged with leads electrically shorted together by conductive foam, aluminum foil, or comparable conductive material).
7. Immediately before removing the protective material from the leads of replacement ES devices, touch the protective material to the chassis or circuit assembly into which the device will be installed.

<p>CAUTION: Be sure that no power is applied to the chassis or circuit, and observe all other safety precautions.</p>

8. Minimize bodily movements when handling unpackaged replacement ES devices. (Otherwise harmful motion such as the brushing together clothes fabric or the lifting your foot from a carpeted floor can generate enough static electricity to damage ES devices).

◆ General Soldering Guidelines

1. Use a grounded-tip, low-wattage soldering iron with appropriate tip size and shape that will maintain tip temperature between a 550°F-660°F (288°C-316°C) range.
2. Use an appropriate gauge of RMA resin-core solder composed of 60 parts tin/40 parts lead.
3. Keep the soldering iron tip clean.
4. Thoroughly clean the surface to be soldered. Use a small wire-bristle (0.5 inch or 1.25cm) brush with a metal handle. Do not use freon-propelled spray-on cleaners.
5. Use the following soldering technique:
 - a. Allow the soldering iron tip to reach normal temperature (550°F to 660°F or 288°C to 316°C)
 - b. Hold the soldering iron tip and solder strand against the component lead until the solder melts.
 - c. Quickly move the soldering iron tip to the junction of the component lead and the printed circuit foil, and hold it there until the solder flows onto and around both the component lead and the foil.
 - d. Closely inspect the solder area and remove any excess or splashed solder with a small wire-bristle brush.

<p>CAUTION: Work quickly to avoid overheating the circuit board printed foil.</p>

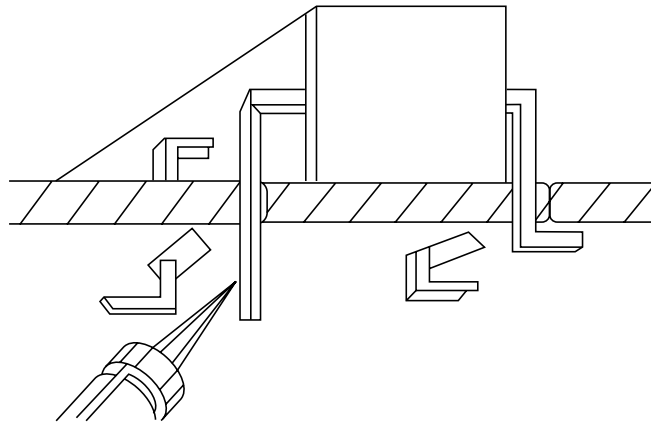

FIGURE 1. USE SOLDERING IRON TO PRY LEADS

◆ IC Removal/Replacement

Some utilized chassis circuit boards have slotted (oblong) holes through which the IC leads are inserted and then bent flat against the circuit foil. When holes are slotted, the following technique should be used to remove and replace the IC. When working with boards using the familiar round hole, use the standard technique as outlined in paragraphs 5 on the page under the title of general soldering guidelines.

◆ Removal

1. Desolder and straighten each IC lead in one operation by gently prying up on the lead with the soldering iron tip as the solder melts.
2. Draw away the melted solder with an anti-static suction-type solder removal device (or with desoldering braid before removing the IC).

◆ Replacement

1. Carefully insert the replacement IC in the circuit board.
2. Carefully bend each IC lead against the circuit foil pad and solder it.
3. Clean the soldered areas with a small wire-bristle brush. (It is not necessary to reapply acrylic coating to the area).

◆ “Small-Signal” Discrete Transistor Removal/Replacement

1. Remove the defective transistor by clipping its leads as close as possible to the component body.
2. Bend the ends of each of three leads remaining on the circuit board into a “U” shape.
3. Bend the replacement transistor leads into a “U” shape.
4. Connect the replacement transistor leads to the corresponding leads extending from the circuit board and crimp the “U” with long nose pliers to ensure metal-to-metal contact, then solder each connection.

◆ Power IC, Transistor or Devices Removal/Replacement

1. Heat and remove all solders from the device leads.
2. Remove the heatsink mounting screw (if applicable).
3. Carefully remove the device from the circuit board.
4. Insert new device in circuit board.
5. Solder each device lead and then clip off excess lead.
6. Replace heatsink.

◆ Diode Removal/Replacement

1. Remove defective diode by clipping its leads as close as possible to diode body.
2. Bend the two remaining leads perpendicularly to the circuit board.
3. Observing diode polarity, wrap each lead out of the new diode around the corresponding lead on the circuit board.
4. Securely crimp each connection and solder it.
5. Inspect the solder joints of the two “original” leads on the circuit board copper side. If they are not shiny, reheat them and apply additional solder if necessary.

TECHNICAL INFORMATION

Panel	Size	15-inch (38 cm) diagonal
	Pixel Pitch	0.297 x 0.297 mm
	Viewing Angle	75°(Right/Left)
		70°(up), 70°(down)
	Contrast Ratio	350:1 contrast ratio (typ)
	Brightness	250cd/m ² brightness (typ)
Color Filter	RGB vertical stripe	
Synchronization	Horizontal	30 - 62 KHz
	Vertical	50 - 75 Hz
Video Bandwidth	80 MHz	
Max Resolution	1024 x 768@ 75Hz	
Colors	6 bit (With dithering 16.7M Colors)	
Display Area	304.1mm x 228.1mm	
Input Signal	Video	RGB analog (0.7Vp-p, 75ohms)
	Sync	H/V separate (TTL)
Input Signal Connector	15 pin mini D-Sub	
Plug and Play	DDC1/2B/CI	
Power Source	100-240 Vac, 50/60 Hz (Free Voltage)	
Power Consumption	25.5 W	
Dimension-W x H x D	390 x 396 x 205 mm (with stand)	
	390 x 325 x 70.5 mm (without stand)	
Weight(net/gross)	4.6/6.1 Kg	
	10/13.2 lbs	
Power Saving	EPA, VESA DPMS, Nutek Compliant	
Tilt/Swivel Range	Tilt	5° forward, 30° backward
	Swivel	90° leftward, rightward
Operating Temperature	10 ~ 40°C /50 ~ 104°F	

GENERAL INFORMATION

This TFT LCD monitor automatically scans all horizontal frequencies from 30KHz to 62KHz, and all vertical frequencies from 50Hz to 75Hz. This TFT LCD monitor supports IBM PC, PC/XT, PC/AT, personal System/2 (PS/2), Apple Macintosh, and compatible users crisp text and vivid color graphics display when using the following graphics adapters : (VGA, Super VGA, VESA and XGA and Apple Macintosh Video Card). And so, this TFT LCD monitor has a maximum horizontal resolution of 1024 dots and a maximum vertical resolution of 768 lines for superior clarity of display.

By accepting analog signal inputs which level is zero to 0.7 Volts. This TFT LCD monitor can display and 262, 144 colors depending on the graphics adapter and software being used. (available used to 8 bit panel is 16.7M colors)

◆ Abbreviations

ADJ	Adjustment
AFC	Automatic Frequency Control
TFT-LCD	Thin Film Transistor Liquid Crystal Display
CCFL	Cold Cathode Fluorescent Lamp
H.SYNC	Horizontal Synchronization
OSC	Oscillator
P.S.U	Power Supply Unit
PWA	Printed Circuit Board Wiring Assembly
R.G.B	Red, Green, Blue
V.Sync	Vertical Synchronization
ADC	Analog Display Converter

PIN CONNECTOR

Pin	Signal
1	Red
2	Green
3	Blue
4	GND
5	GND
6	GND - Red
7	GND - Green
8	GND - Blue
9	+5Vdc
10	GND - H.Sync
11	GND - V.Sync
12	Bi-directional Data (SDA)
13	Horizontal Sync
14	Vertical Sync (VCLK)
15	Data Clock (SCL)

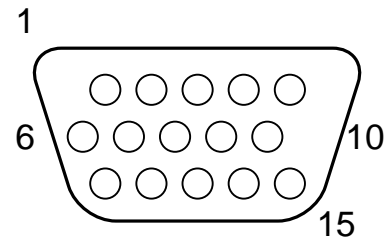

Arrangement of 15-pin D-sub connector

CAUTIONS FOR ADJUSTMENT AND REPAIR

- Degaussing is always required when adjusting purity or convergence.
- The white balance adjustment has been done by a color analyzer in factory. The adjustment procedure, described in the service manual is made by a visual check.
- Allow 20 minutes warm-up time for the display before checking or adjusting only electrical specification or function.
- Reform the leadwire after any repair work.

◆ Caution For Servicing

- In case of servicing or replacing inverter, high voltage sometimes remains in the output of the inverter. Completely discharge high voltage before servicing or replacing inverter to prevent a shock to the serviceman.

OPERATION AND ADJUSTMENT

Control Panel



AUTO



- The AUTO button launches the AUTO TRACKING function directly.

EXIT



- The EXIT button turns the OSD (On-Screen Display) window off.
- This button moves from sub menu to top menu in the OSD window.

MENU



- The MENU button turns the OSD window on.
- This button moves from top menu to sub menu in the OSD window.

BRIGHTNESS



- The button moves cursor to the left or high window in the OSD window.
- This button decreases the value of any selected function.

BRIGHTNESS



- The button moves cursor to the right or low window in the OSD window.
- This button increases the value of any selected function.

Hot Key

AUTO



BRIGHTNESS

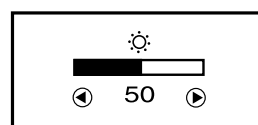



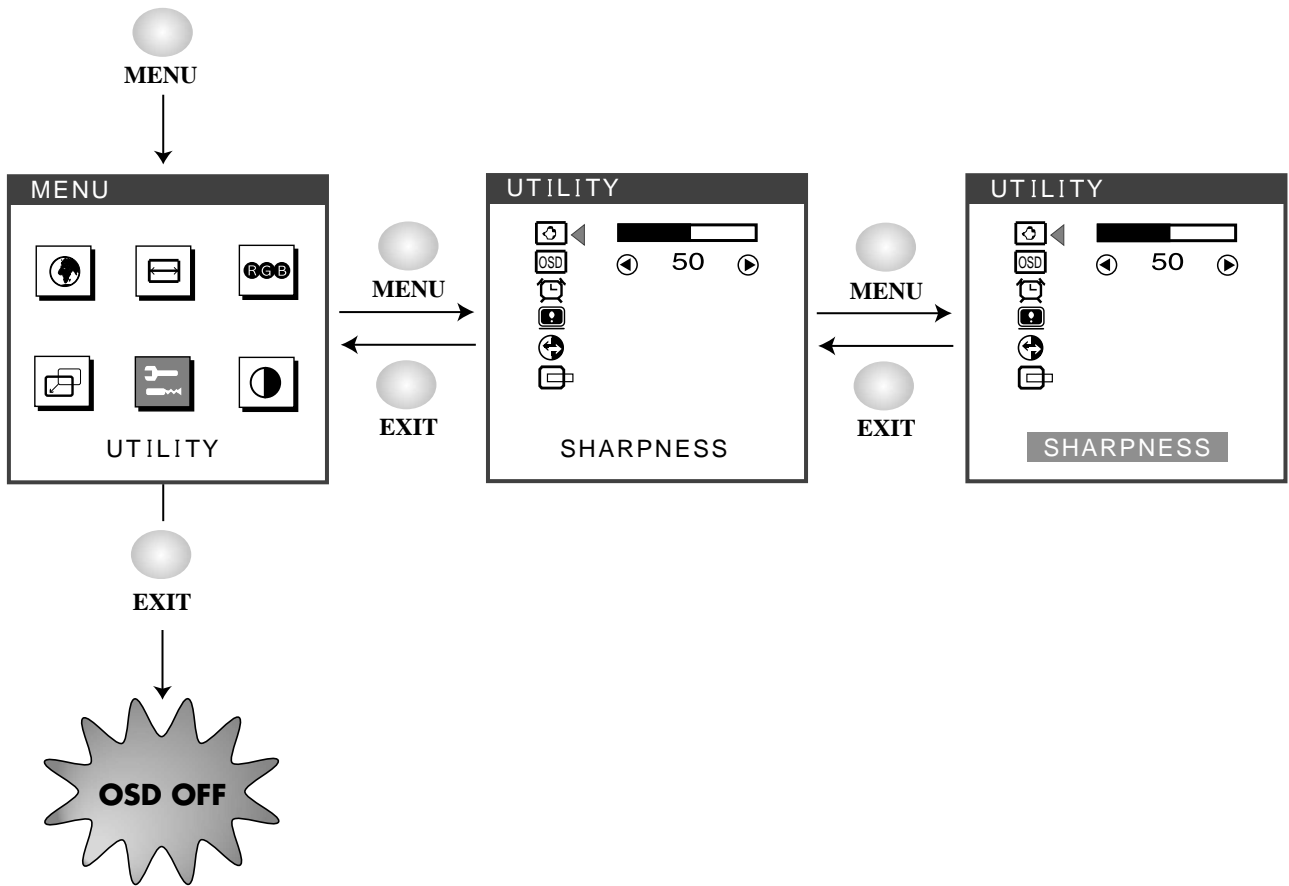



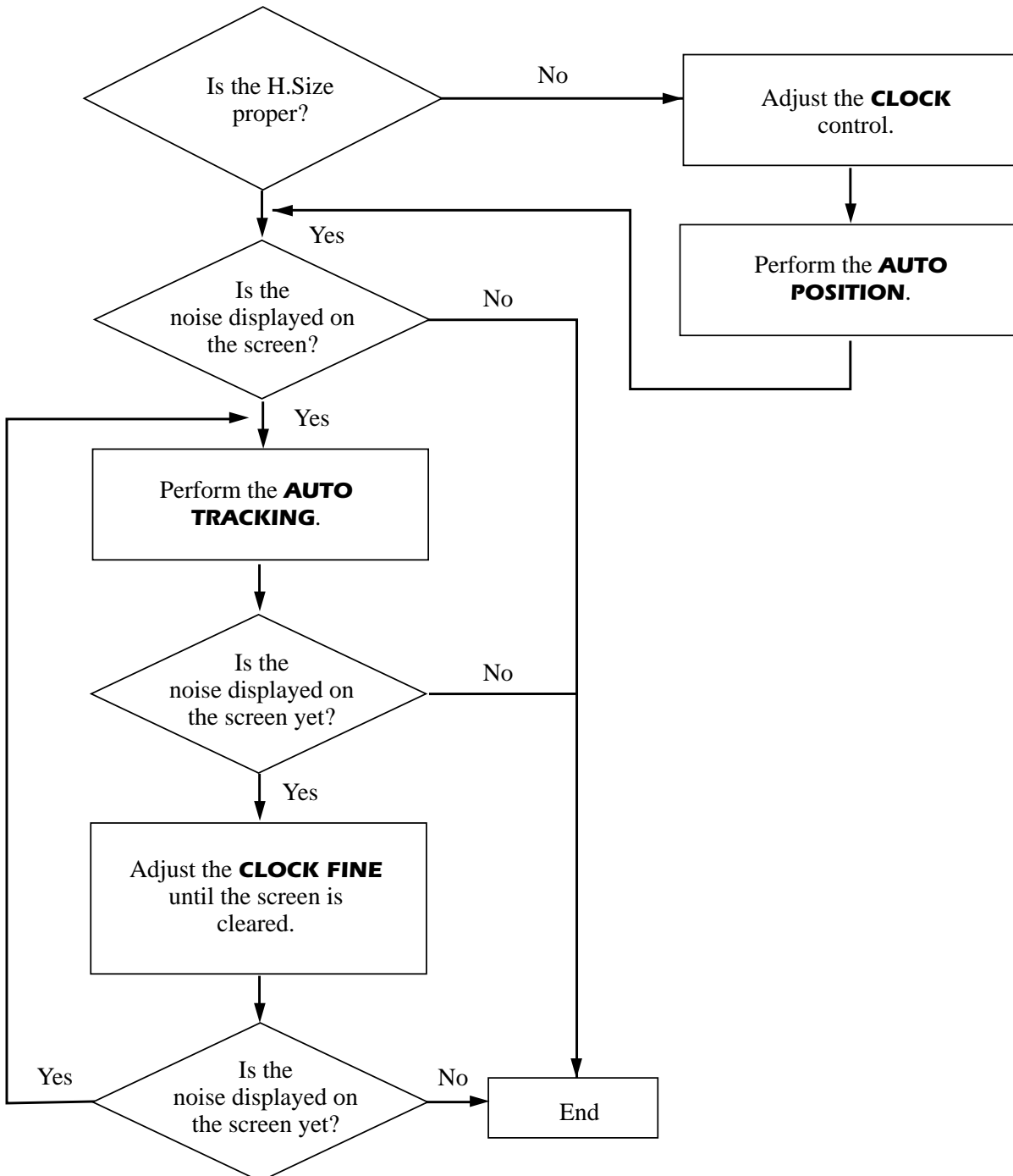









Key Process



Adjustment Procedure



OSD Functions

ICON	CONTROL	FUNCTIONS
	LANGUAGE	Select language for OSD (6 languages).
	CLOCK	Adjust the width (horizontal size) of the screen image.
	CLOCK FINE	Sharpen the focus by aligning the illuminated pixels and adjust until the screen image looks focused, crisp and sharp. Adjusting the CLOCK FINE after the CLOCK adjustment will produce a clear screen.
	AUTO TRACKING	Adjust the horizontal & vertical picture image quality and size.
	COLOR TEMP	Choose different preset color temperatures or set your own customized color parameters.
	RED CONTROL	Adjust the red color.
	GREEN CONTROL	Adjust the green color.
	BLUE CONTROL	Adjust the blue color.
	H. CENTER & V. CENTER	Adjust the position of the display horizontally(left or right) and vertically (up or down).
	SHARPNESS	Adjust the display image quality (if the screen proceed to scaling up).
	OSD POSITION	Adjust the OSD position horizontally (left or right) and vertically (up or down).
	OSD TIME OUT	Adjust the display OSD Menu.
	STATUS	Display horizontal & vertical frequency and polarity.
	RECALL	Reset the screen to the Factory Preset Display Settings.
	AUTO POSITION	Choose automatically the proper horizontal position and vertical position & size of the screen image.
	CONTRAST	Adjust the contrast of image, the difference between light and dark areas on the screen.

Self Diagnosis

When the monitor doesn't display, if you press any key, Self Diagnosis screen is displayed. Self Diagnosis function checks if the status of the monitor is No Signal or Out of range.



No Signal screen is displayed when the D-Sub signal connector is not connected or the status of the monitor is on DPMS mode.



Out of Range screen is displayed when the applied frequency is under or over normal range.

■ Normal range
(Non-interlaced mode only)

H : 30 - 62 KHz

V : 50 - 75 Hz

ALIGNMENT PROCEDURE

Standard Check point

1. Power source : 100 - 240Vac, 50/60Hz.
2. Aging : Take at least 20 minutes warm-up time.
3. Signal
 - Video input : Analog 0.7Vpp 75Ω terminal positive polarity
 - Synchronizing : acceptable negative or positive at TTL level
 - Max. Resolution : 1024 x 768 @75Hz
 - Frequency
 - Horizontal : 30KHz - 62KHz
 - Vertical : 50Hz - 75Hz (available only non interlace mode)

Adjustment

1. Smart scaling set to 69%.
 2. Contrast set to 90%
 3. Brightness set to 50%
 4. Switching to factory alignment mode
 - Press power key with Brightness left key at the power off status.
 5. Video level adjustment
 - Receive stair pattern of 16 step (doesn't care any mode).
 - Readjust coarse R, G, B in TDA8752 menu before saturaton point.
 6. Set up the tracking
 - See the user's manual at page 8th.
 7. Switching to user's mode
 - If turn-off and turn-on then switched to user's mode.
- * All of adjusted data stores by fade out of OSD.

TROUBLESHOOTING HINTS

1. Abnormal mode detect

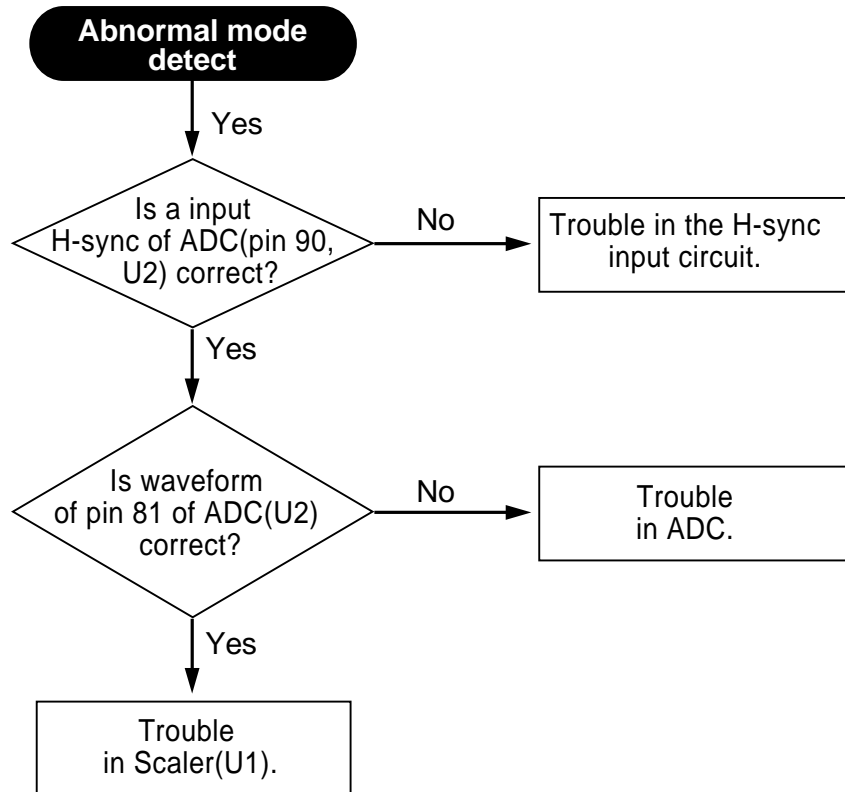

2. Trouble in Power on

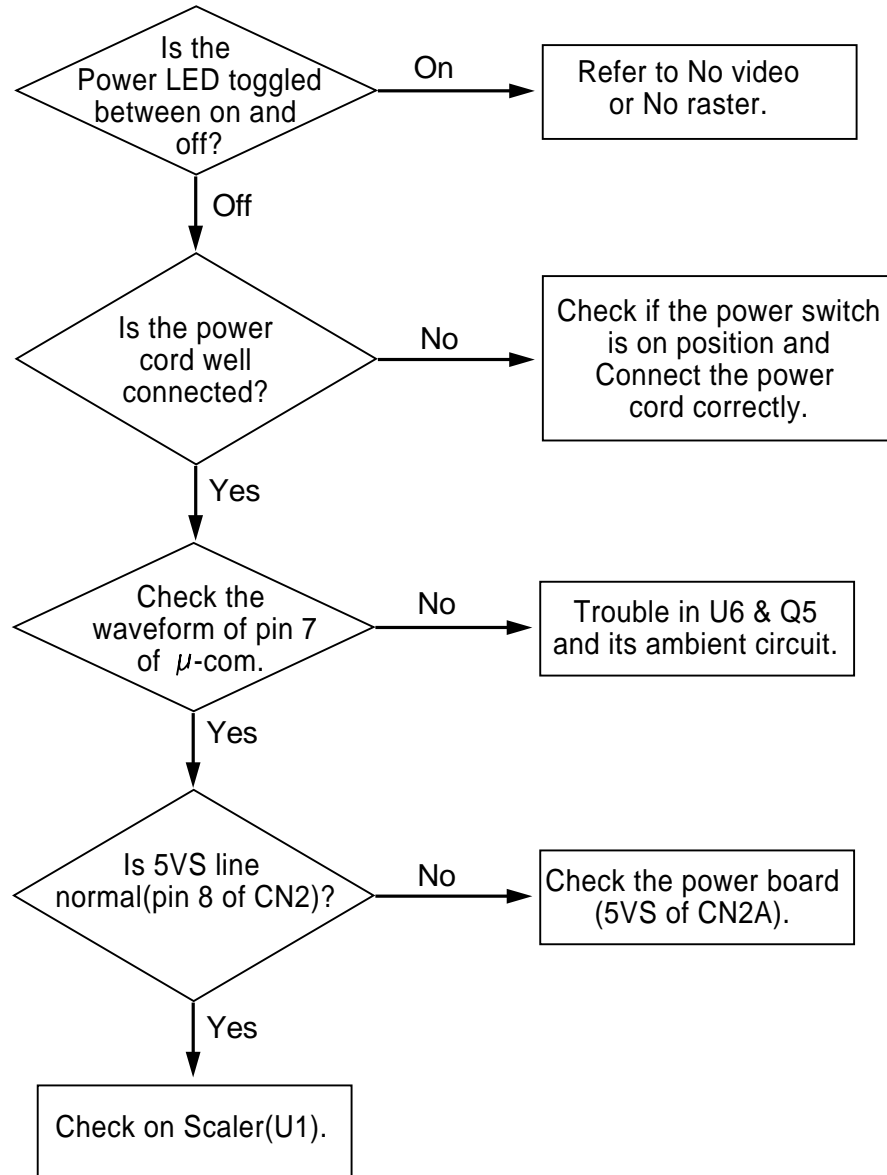

3. No Raster

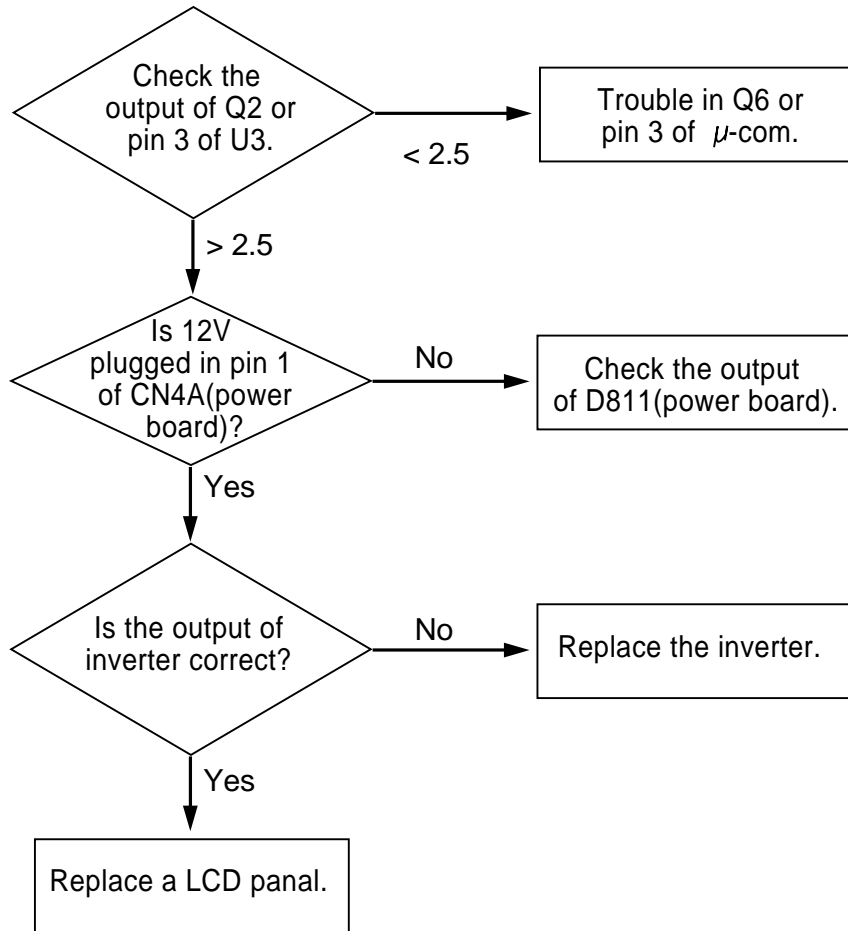

4. One color is missing

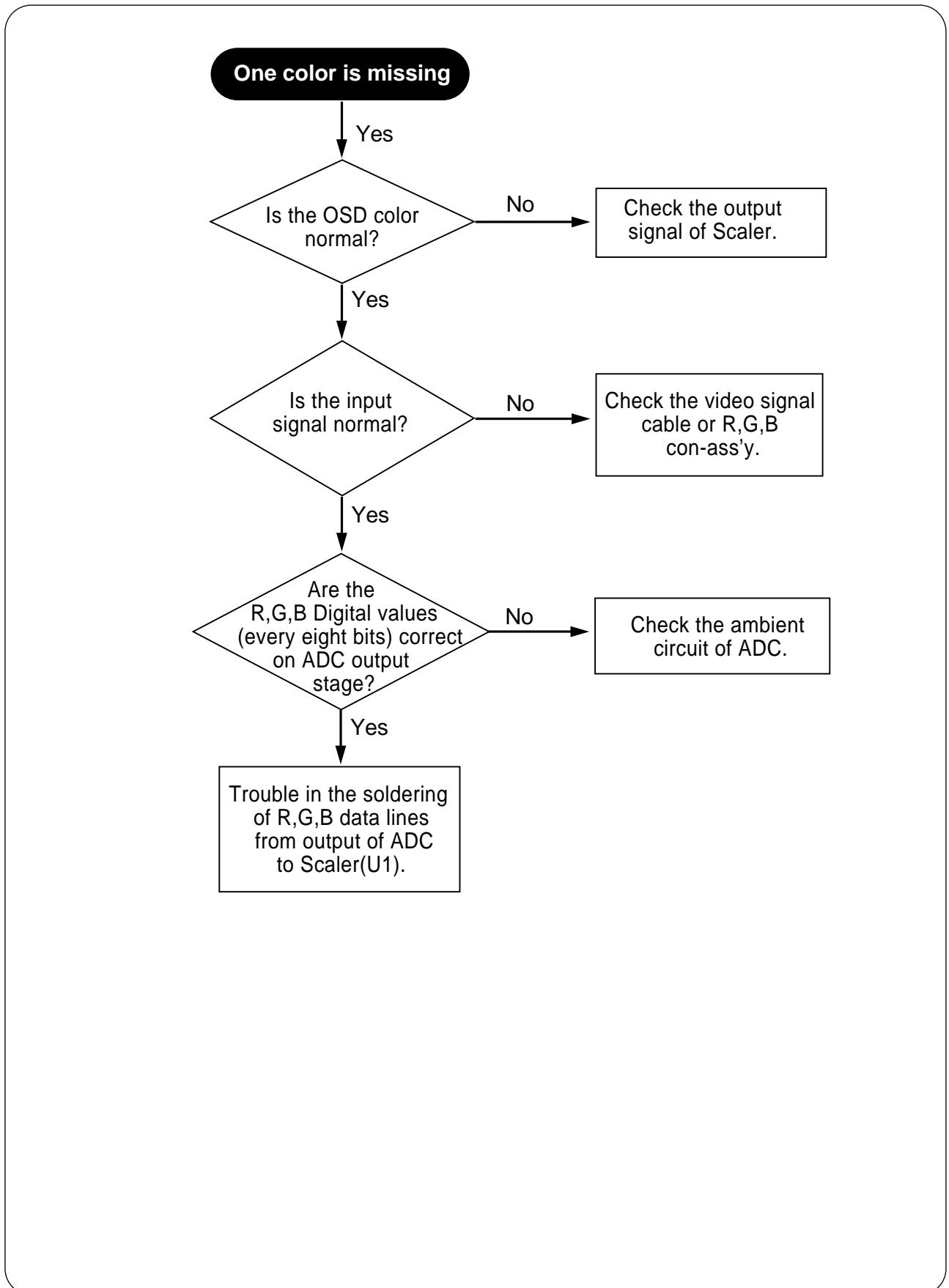

5. No Video

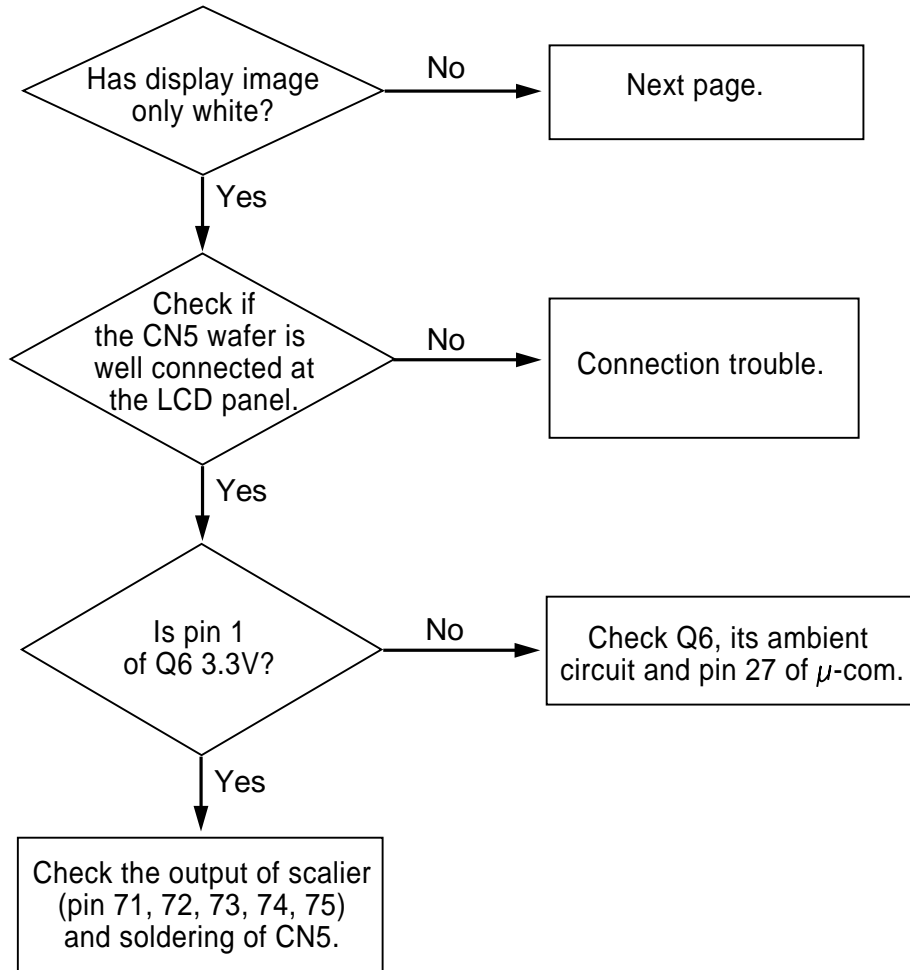

5-1. No Video

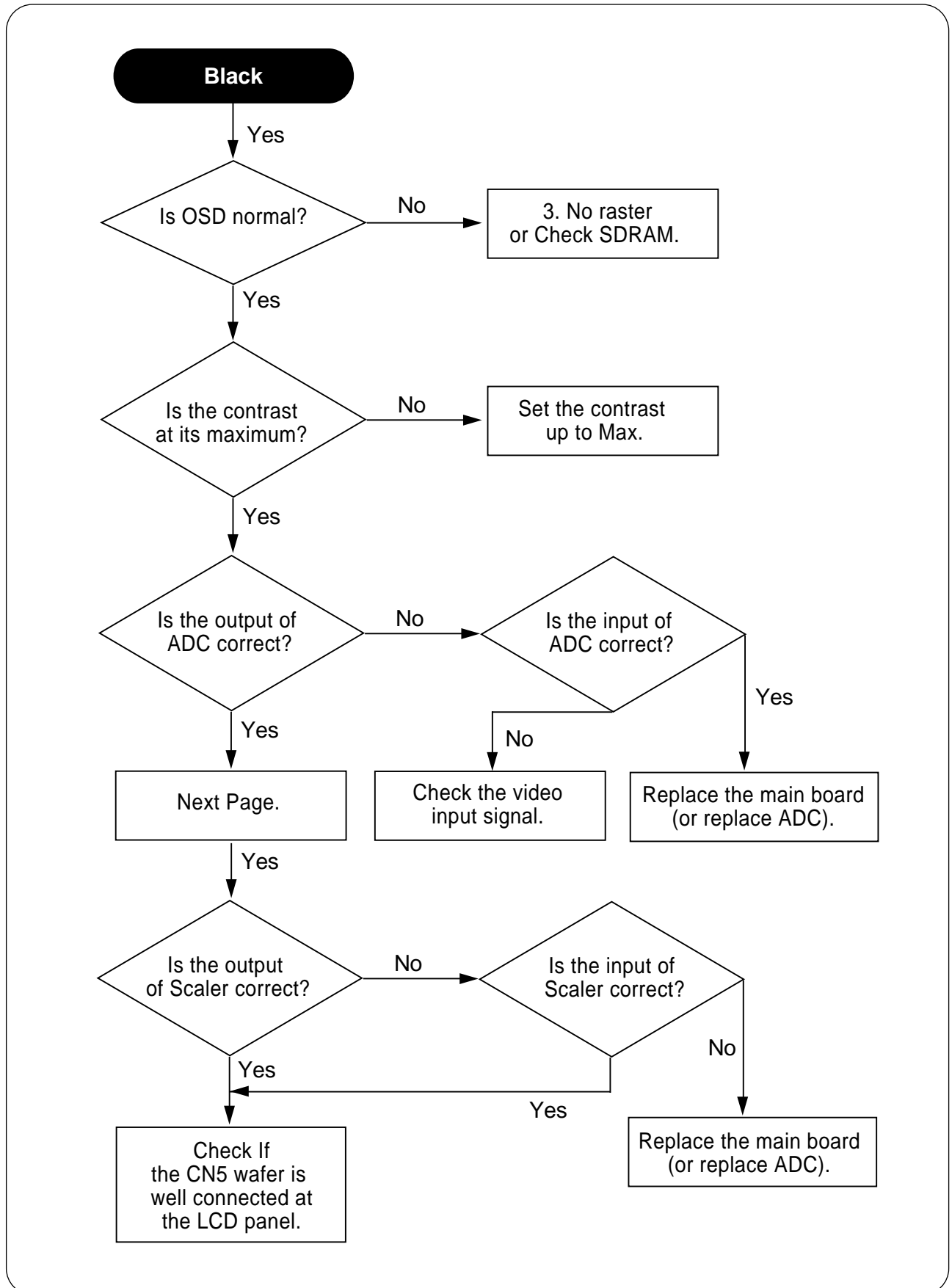

6. Power Problem

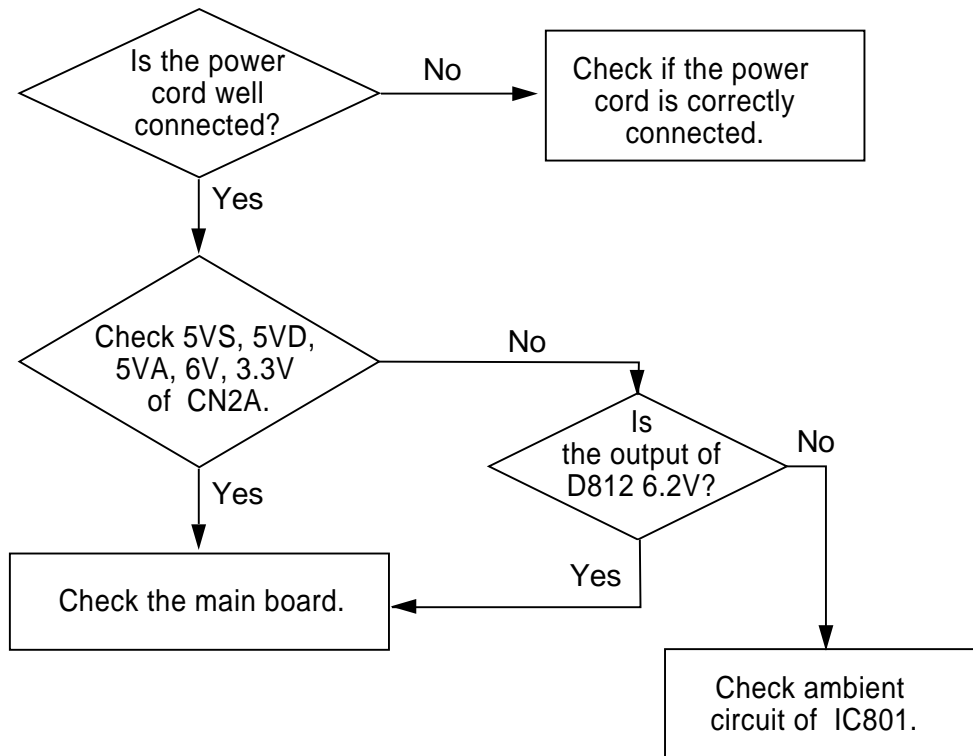

BLOCK DIAGRAM

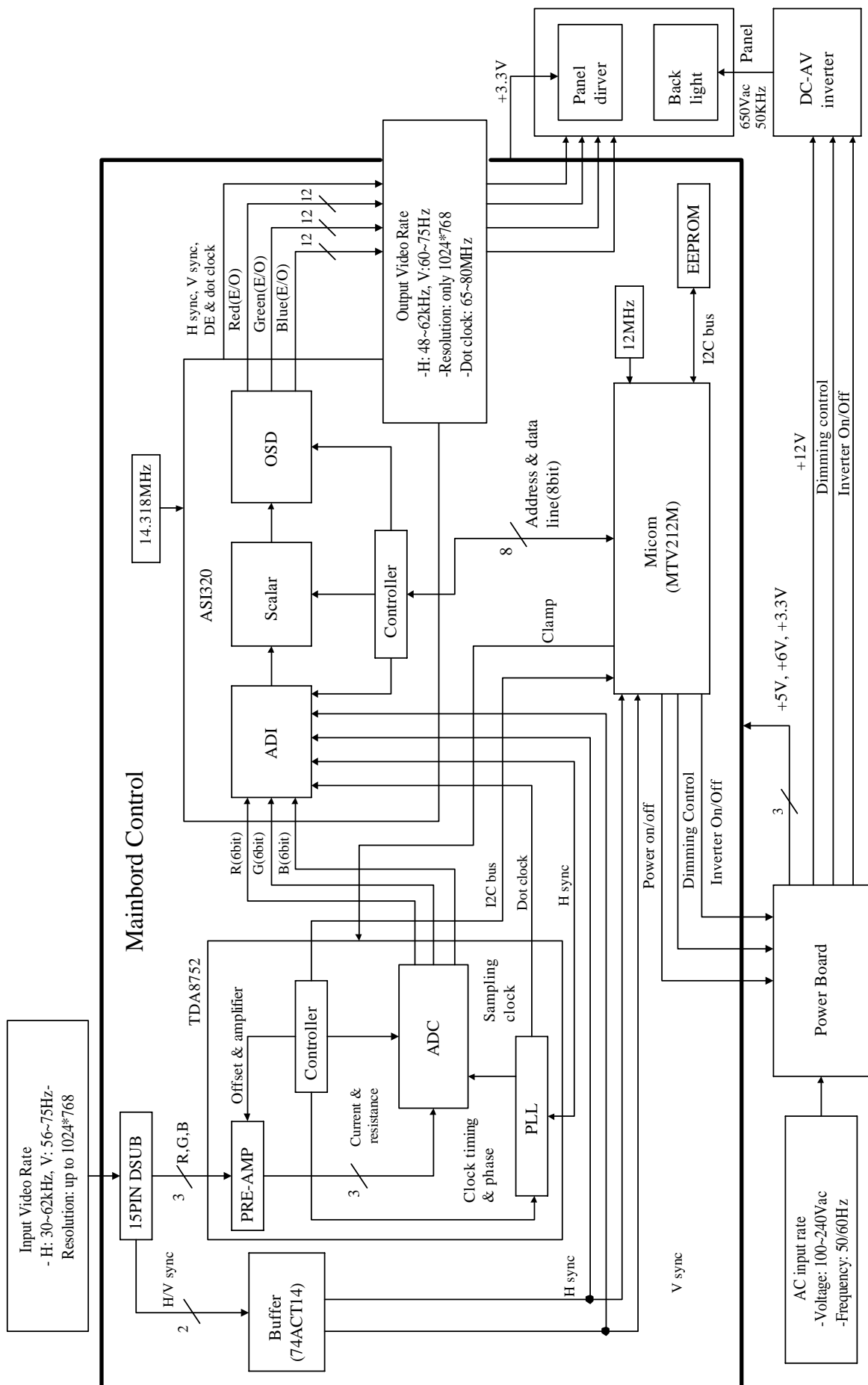

PCB LAYOUT

Main PCB Component Side

Main PCB Solder Side

Power & D-Sub PCB Component Side

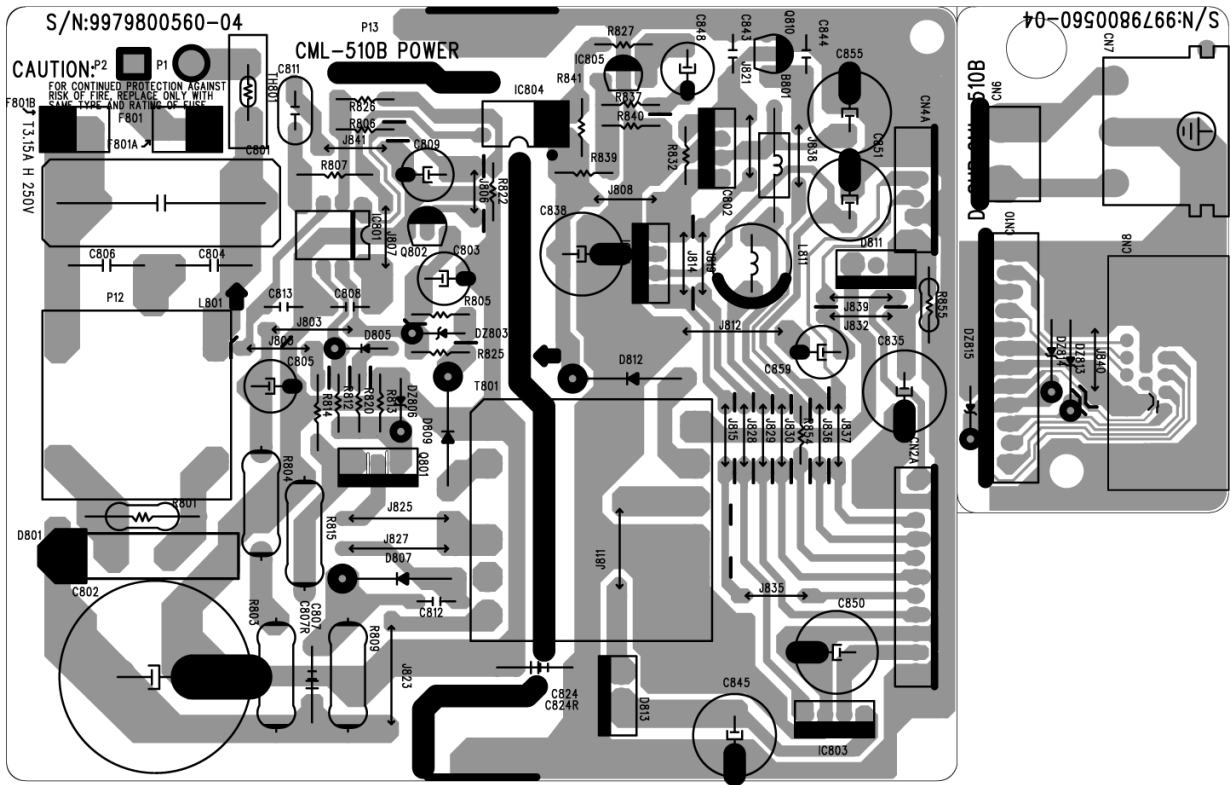

Power & D-Sub PCB Solder Side

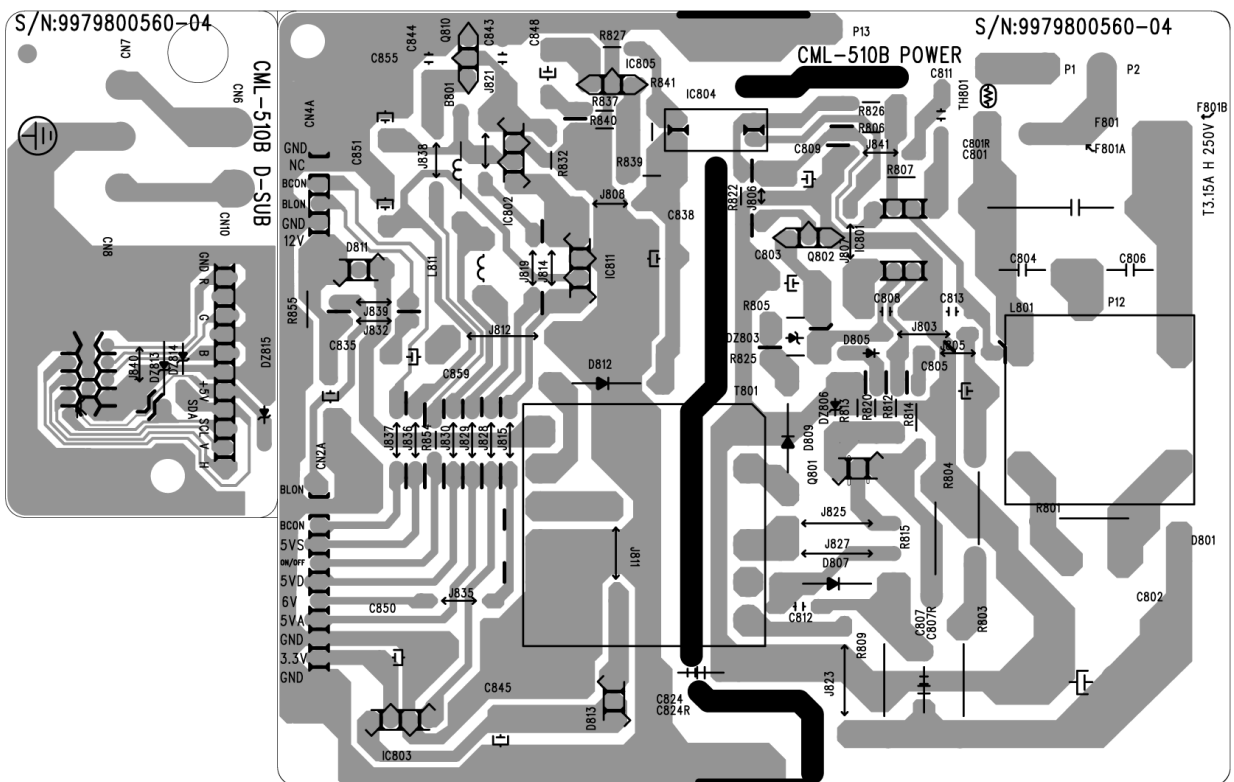

SCHEMATIC DIAGRAM

Main Section

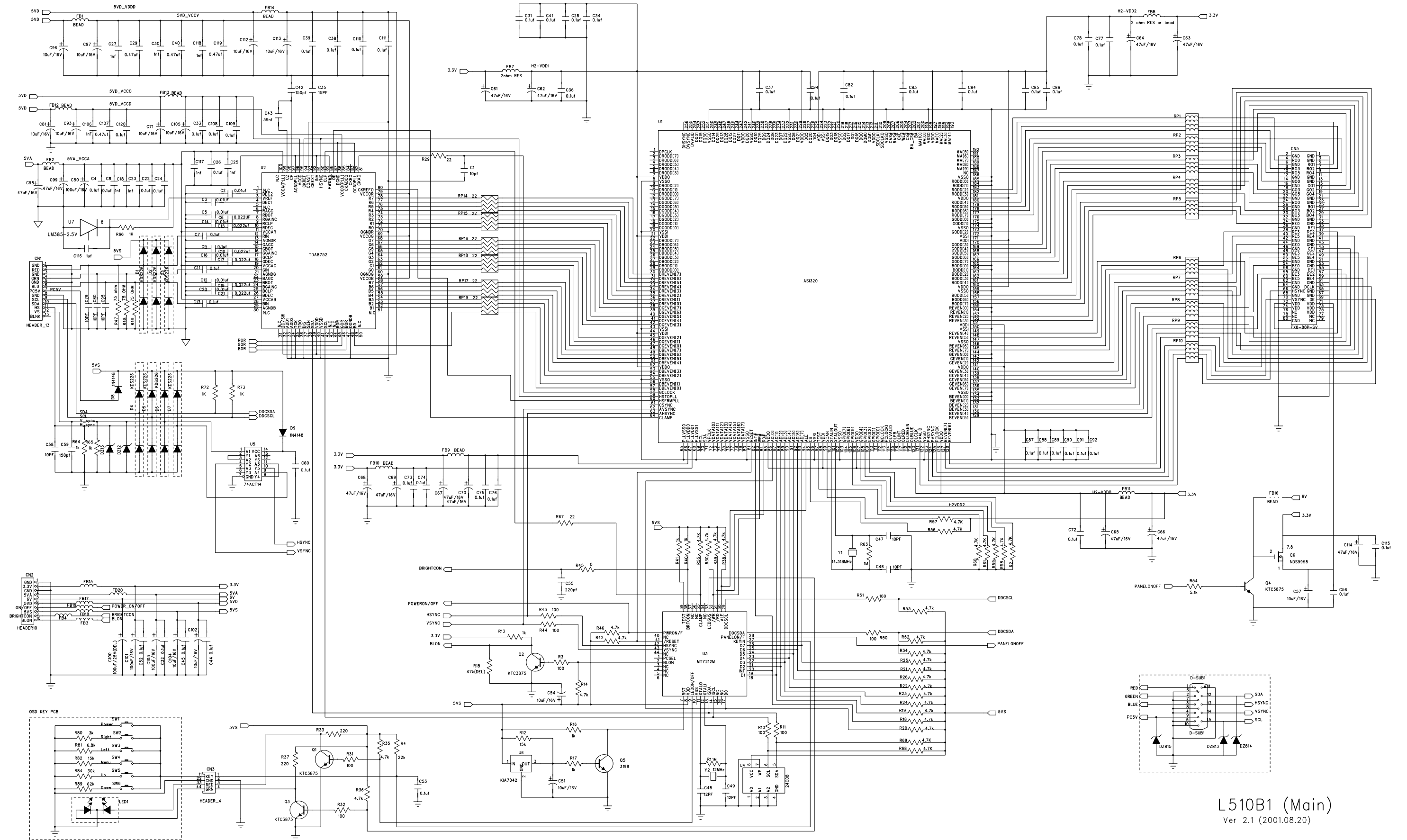

L510B1 (Main)
Ver 2.1 (2001.08.20)

SMPS Section

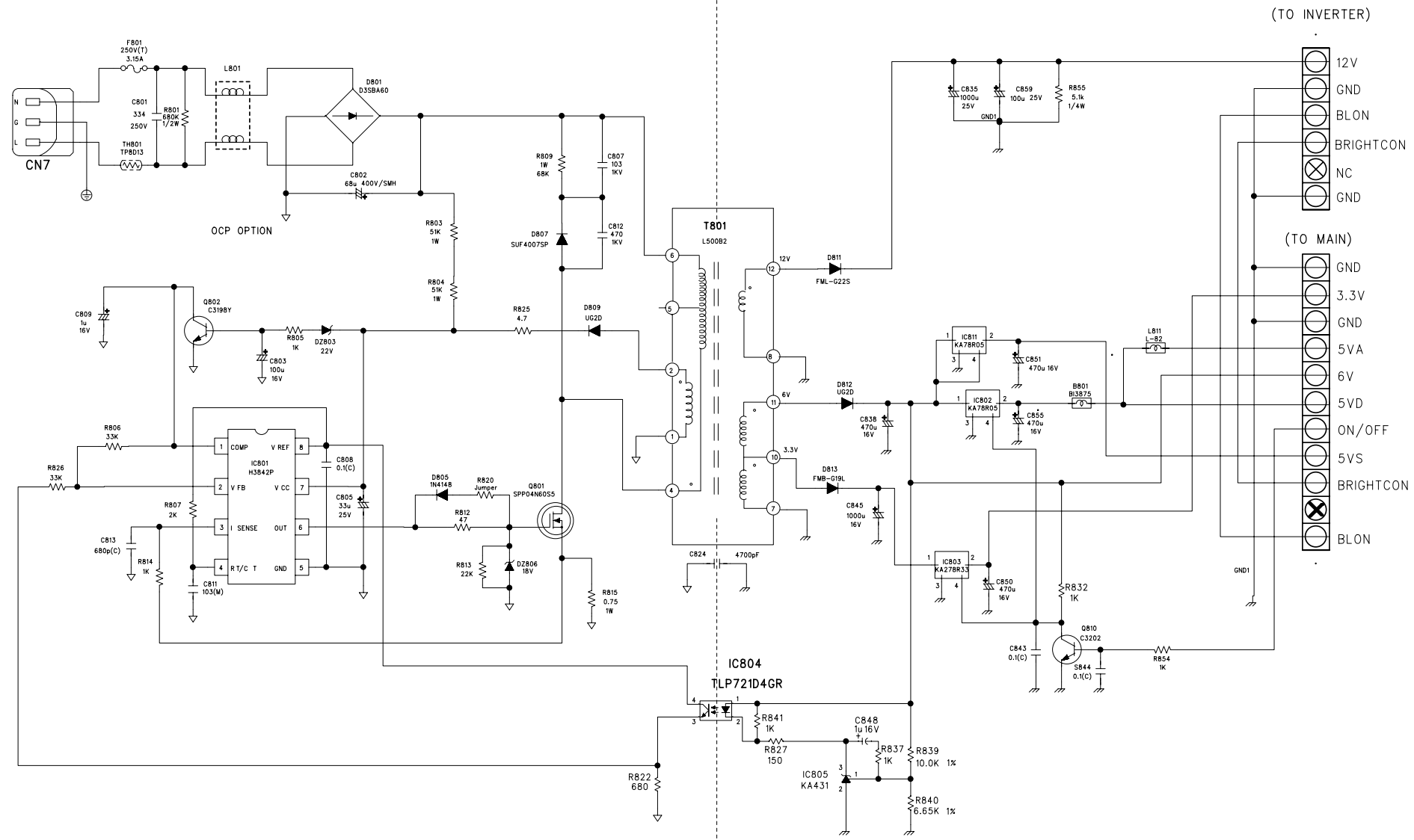

CML-510B-Power Modular
Ver 3.1 (2001. 05. 24)

EXPLODED VIEW & MECHANICAL PARTS LIST

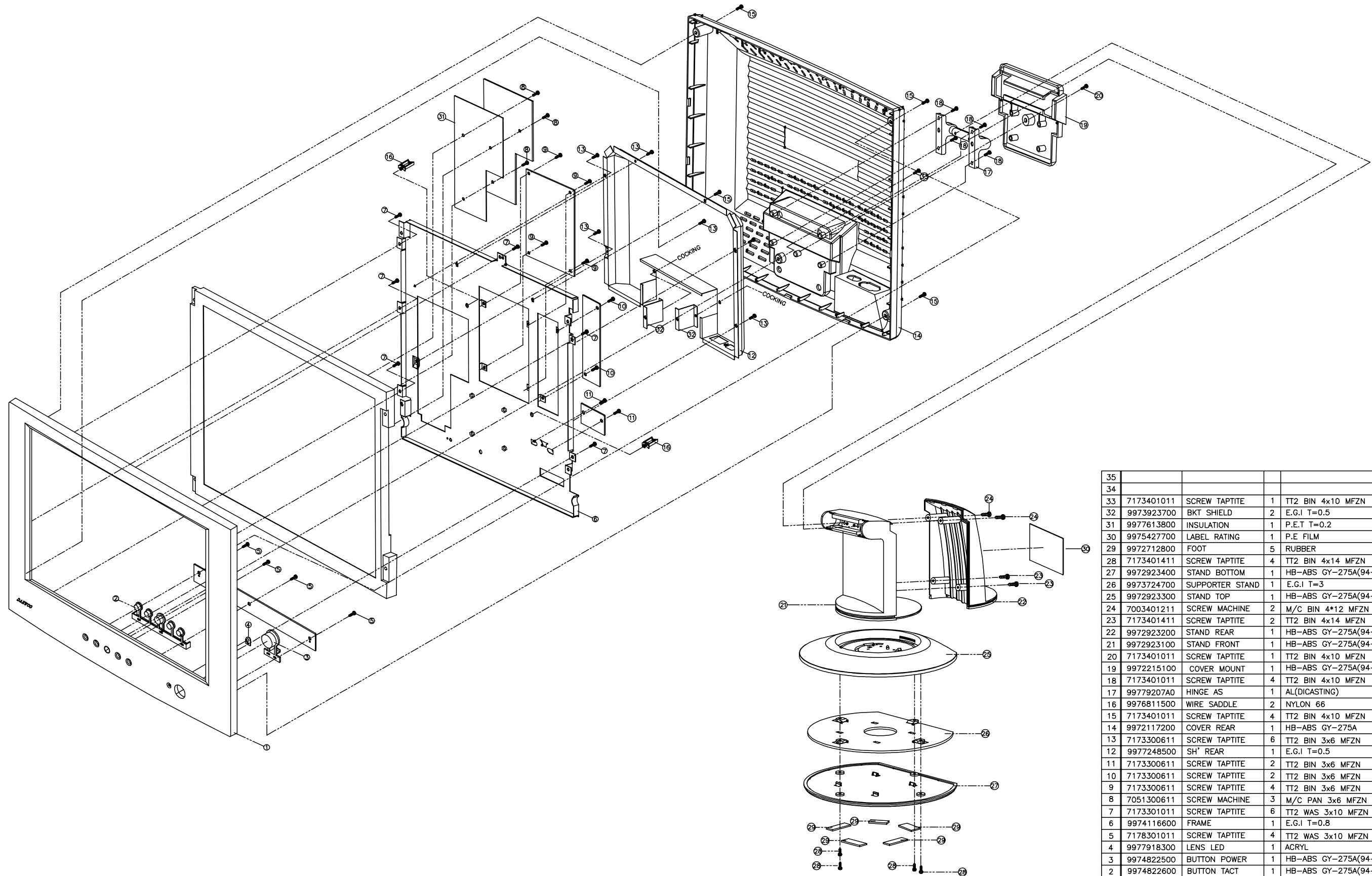

NO	PART CODE	PART NAME	Q'TY	DESCRIPTION	REMARK
35					
34					
33	7173401011	SCREW TAPTITE	1	TT2 BIN 4x10 MFZN	C/REAR+C/FRONT
32	9973923700	BKT SHIELD	2	E.G.I T=0.5	+SH' REAR(COOKING)
31	9977613800	INSULATION	1	P.E.T T=0.2	
30	9975427700	LABEL RATING	1	P.E FILM	
29	9972712800	FOOT	5	RUBBER	
28	7173401411	SCREW TAPTITE	4	TT2 BIN 4x14 MFZN	STAND TOP+STAND BOTTOM
27	9972923400	STAND BOTTOM	1	HB-ABS GY-275A(94-HB)	
26	9973724700	SUPPORTER STAND	1	E.G.I T=3	
25	9972923300	STAND TOP	1	HB-ABS GY-275A(94-HB)	
24	7003401211	SCREW MACHINE	2	M/C BIN 4*12 MFZN	STAND AS'+HINGE AS'
23	7173401411	SCREW TAPTITE	2	TT2 BIN 4x14 MFZN	STAND FRONT+STAND REAR
22	9972923200	STAND REAR	1	HB-ABS GY-275A(94-HB)	
21	9972923100	STAND FRONT	1	HB-ABS GY-275A(94-HB)	
20	7173401011	SCREW TAPTITE	1	TT2 BIN 4x10 MFZN	C/MOUNT+C/REAR
19	9972215100	COVER MOUNT	1	HB-ABS GY-275A(94-HB)	
18	7173401011	SCREW TAPTITE	4	TT2 BIN 4x10 MFZN	HINGE AS+C/REAR
17	99779207A0	HINGE AS	1	AL(DICASTING)	HINGE BODY+HINGE STAND
16	9976811500	WIRE SADDLE	2	NYLON 66	LWS-201
15	7173401011	SCREW TAPTITE	4	TT2 BIN 4x10 MFZN	FRONT+REAR
14	9972117200	COVER REAR	1	HB-ABS GY-275A	
13	7173300611	SCREW TAPTITE	6	TT2 BIN 3x6 MFZN	SH' REAR+FRAME
12	9977248500	SH' REAR	1	E.G.I T=0.5	INVERTER PCB+REAR
11	7173300611	SCREW TAPTITE	2	TT2 BIN 3x6 MFZN	D-SUB PCB+FRAME
10	7173300611	SCREW TAPTITE	2	TT2 BIN 3x6 MFZN	INVERTER PCB+FRAME
9	7173300611	SCREW TAPTITE	4	TT2 BIN 3x6 MFZN	REAR PCB+FRAME
8	7051300611	SCREW MACHINE	3	M/C PAN 3x6 MFZN SW	REAR PCB+FRAME
7	7173301011	SCREW TAPTITE	6	TT2 WAS 3x10 MFZN	FRAME+FRONT
6	9974116600	FRAME	1	E.G.I T=0.8	FRONT+CON/PCB
5	7178301011	SCREW TAPTITE	4	TT2 WAS 3x10 MFZN	CONT' PCB+FRONT
4	9977918300	LENS LED	1	ACRYL	
3	9974822500	BUTTON POWER	1	HB-ABS GY-275A(94-HB)	
2	9974822600	BUTTON TACT	1	HB-ABS GY-275A(94-HB)	
1	9972019801	COVER FRONT	1	HB-ABS GY-275A	
NO	PART CODE	PART NAME	Q'TY	DESCRIPTION	REMARK

INFORMATION OF PART DESCRIPTION

Important Safety Notice

Components identified with the International Symbol have special characteristics important for safety. When replacing any components, use only manufacturer's specified parts.

Abbreviation of Description

RESISTOR Description

Tolerance	
F	± 1%
J	± 5%
K	± 10%
M	± 20%
G	± 2%

Example:

Fig & Index	Part No	Description
R101	Resistors	
	RD-4Z820J	Carbon : 82 <u>J</u>
R30	HRFS472JBA	Chip 4.7K OHM <u>J</u>

CAPACITOR Description

Tolerance	
C	± 0.25pF
D	± 0.5%
F	± 1pF
J	± 5%
K	± 10%
P	± 100% ~ 0%
Z	± 80% ~ -

Example:

Fig & Index	Part No	Description
C28	Capacitors	
	HCFK104ZBA	Chip Cera 50V Z
	HCBK393KBA	Chip Cera 50V K
C44	HCQK102JBA	Chip Cera 50V J

ELECTRICAL PARTS LIST

The components identified by mark \triangle have special characteristics important for safety and x-ray radiation. These should be replaced only with the types specified in the parts list.

LOC	PART-CODE	PART-NAME	PART-DESC	LOC	PART-CODE	PART-NAME	PART-DESC
00020	W3415M731-	CORD POWER	C5 H03VV-F 3X0.75 1.8M BK	C29	HCFF474ZBA	C CHIP CERA	Y5V 16V 0.47MF Z 1608
00040	9970800035	CABLE SIGNAL AS	15P+15P/DDC=1.5M(GY275A)	C3	HCBK103KBA	C CHIP CERA	50V X7R 0.01MF K 1608
B801	5PB13857--	COIL BEAD	BI3857(AXIAL)	C30	HCBK102KBA	C CHIP CERA	50V X7R 1000PF K 1608
C1	HCQK100JBA	C CHIP CERA	50V CH 10PF J 1608	C31	HCFK104ZBA	C CHIP CERA	50V Y5V 0.1MF Z 1608
C10	HCBK223KBA	C CHIP CERA	50V X7R 0.022MF K 1608	C32	HCFK104ZBA	C CHIP CERA	50V Y5V 0.1MF Z 1608
C101	HCENH101MD	C CHIP ELECTRO	MV 25V 100MF D8.0XH6.3	C33	HCFK104ZBA	C CHIP CERA	50V Y5V 0.1MF Z 1608
C102	HCENH101MD	C CHIP ELECTRO	MV 25V 100MF D8.0XH6.3	C34	HCFK104ZBA	C CHIP CERA	50V Y5V 0.1MF Z 1608
C103	HCENH101MD	C CHIP ELECTRO	MV 25V 100MF D8.0XH6.3	C35	HCQK150JBA	C CHIP CERA	50V CH 15PF J 1608
C104	HCEKF100MC	C CHIP ELECTRO	MV 16V 10MF D4.0XH5.2	C36	HCFK104ZBA	C CHIP CERA	50V Y5V 0.1MF Z 1608
C105	HCEKF100MC	C CHIP ELECTRO	MV 16V 10MF D4.0XH5.2	C37	HCFK104ZBA	C CHIP CERA	50V Y5V 0.1MF Z 1608
C106	HCBK102KBA	C CHIP CERA	50V X7R 1000PF K 1608	C38	HCFK104ZBA	C CHIP CERA	50V Y5V 0.1MF Z 1608
C107	HCFF474ZBA	C CHIP CERA	Y5V 16V 0.47MF Z 1608	C39	HCFK104ZBA	C CHIP CERA	50V Y5V 0.1MF Z 1608
C108	HCFK104ZBA	C CHIP CERA	50V Y5V 0.1MF Z 1608	C4	HCFK104ZBA	C CHIP CERA	50V Y5V 0.1MF Z 1608
C109	HCFK104ZBA	C CHIP CERA	50V Y5V 0.1MF Z 1608	C40	HCFF474ZBA	C CHIP CERA	Y5V 16V 0.47MF Z 1608
C11	HCFK104ZBA	C CHIP CERA	50V Y5V 0.1MF Z 1608	C41	HCFK104ZBA	C CHIP CERA	50V Y5V 0.1MF Z 1608
C110	HCFK104ZBA	C CHIP CERA	50V Y5V 0.1MF Z 1608	C42	HCQK151JBA	C CHIP CERA	50V CH 150PF J 1608
C111	HCFK104ZBA	C CHIP CERA	50V Y5V 0.1MF Z 1608	C43	HCBK393KBA	C CHIP CERA	50V X7R 0.039MF K 1608
C112	HCEKF100MC	C CHIP ELECTRO	MV 16V 10MF D4.0XH5.2	C44	HCFK104ZBA	C CHIP CERA	50V Y5V 0.1MF Z 1608
C113	HCEKF100MC	C CHIP ELECTRO	MV 16V 10MF D4.0XH5.2	C45	HCFK104ZBA	C CHIP CERA	50V Y5V 0.1MF Z 1608
C114	HCEDC470MC	C CHIP ELECTRO	MV 6.3V 47MF 5DX5.2H	C46	HCQK120JBA	C CHIP CERA	50V CH 12PF J 1608
C115	HCFK104ZBA	C CHIP CERA	50V Y5V 0.1MF Z 1608	C47	HCQK120JBA	C CHIP CERA	50V CH 12PF J 1608
C116	HCFD105ZBA	C CHIP CERA	Y5V 10V 1MF Z 1608	C48	HCQK120JBA	C CHIP CERA	50V CH 12PF J 1608
C117	HCBK102KBA	C CHIP CERA	50V X7R 1000PF K 1608	C49	HCQK120JBA	C CHIP CERA	50V CH 12PF J 1608
C118	HCBK102KBA	C CHIP CERA	50V X7R 1000PF K 1608	C5	HCBK103KBA	C CHIP CERA	50V X7R 0.01MF K 1608
C119	HCFF474ZBA	C CHIP CERA	Y5V 16V 0.47MF Z 1608	C50	HCENH101MD	C CHIP ELECTRO	MV 25V 100MF D8.0XH6.3
C12	HCBK103KBA	C CHIP CERA	50V X7R 0.01MF K 1608	C51	HCEKF100MC	C CHIP ELECTRO	MV 16V 10MF D4.0XH5.2
C120	HCFK104ZBA	C CHIP CERA	50V Y5V 0.1MF Z 1608	C52	HCFK104ZBA	C CHIP CERA	50V Y5V 0.1MF Z 1608
C13	HCFK104ZBA	C CHIP CERA	50V Y5V 0.1MF Z 1608	C53	HCFK104ZBA	C CHIP CERA	50V Y5V 0.1MF Z 1608
C14	HCBK103KBA	C CHIP CERA	50V X7R 0.01MF K 1608	C54	HCEKF100MC	C CHIP ELECTRO	MV 16V 10MF D4.0XH5.2
C15	HCBK223KBA	C CHIP CERA	50V X7R 0.022MF K 1608	C55	HCQK221JBA	C CHIP CERA	50V CH 220PF J 1608
C16	HCBK103KBA	C CHIP CERA	50V X7R 0.01MF K 1608	C56	HCFK104ZBA	C CHIP CERA	50V Y5V 0.1MF Z 1608
C17	HCBK223KBA	C CHIP CERA	50V X7R 0.022MF K 1608	C57	HCEKF100MC	C CHIP ELECTRO	MV 16V 10MF D4.0XH5.2
C18	HCFK104ZBA	C CHIP CERA	50V Y5V 0.1MF Z 1608	C58	HCQK100JBA	C CHIP CERA	50V CH 10PF J 1608
C19	HCBK223KBA	C CHIP CERA	50V X7R 0.022MF K 1608	C59	HCQK151JBA	C CHIP CERA	50V CH 150PF J 1608
C2	HCBK103KBA	C CHIP CERA	50V X7R 0.01MF K 1608	C6	HCBK223KBA	C CHIP CERA	50V X7R 0.022MF K 1608
C20	HCBK103KBA	C CHIP CERA	50V X7R 0.01MF K 1608	C60	HCFK104ZBA	C CHIP CERA	50V Y5V 0.1MF Z 1608
C21	HCBK223KBA	C CHIP CERA	50V X7R 0.022MF K 1608	C61	HCEDC470MC	C CHIP ELECTRO	MV 6.3V 47MF 5DX5.2H
C22	HCFK104ZBA	C CHIP CERA	50V Y5V 0.1MF Z 1608	C62	HCEDC470MC	C CHIP ELECTRO	MV 6.3V 47MF 5DX5.2H
C23	HCBK102KBA	C CHIP CERA	50V X7R 1000PF K 1608	C63	HCEDC470MC	C CHIP ELECTRO	MV 6.3V 47MF 5DX5.2H
C24	HCFK104ZBA	C CHIP CERA	50V Y5V 0.1MF Z 1608	C64	HCEDC470MC	C CHIP ELECTRO	MV 6.3V 47MF 5DX5.2H
C25	HCBK102KBA	C CHIP CERA	50V X7R 1000PF K 1608	C65	HCEDC470MC	C CHIP ELECTRO	MV 6.3V 47MF 5DX5.2H
C26	HCFK104ZBA	C CHIP CERA	50V Y5V 0.1MF Z 1608	C66	HCEDC470MC	C CHIP ELECTRO	MV 6.3V 47MF 5DX5.2H
C27	HCBK102KBA	C CHIP CERA	50V X7R 1000PF K 1608	C67	HCEDC470MC	C CHIP ELECTRO	MV 6.3V 47MF 5DX5.2H
C28	HCFK104ZBA	C CHIP CERA	50V Y5V 0.1MF Z 1608	C68	HCEDC470MC	C CHIP ELECTRO	MV 6.3V 47MF 5DX5.2H

LOC	PART-CODE	PART-NAME	PART-DESC
C69	HCEDC470MC	C CHIP ELECTRO	MV 6.3V 47MF 5DX5.2H
C7	HCFK104ZBA	C CHIP CERA	50V Y5V 0.1MF Z 1608
C70	HCEDC470MC	C CHIP ELECTRO	MV 6.3V 47MF 5DX5.2H
C71	HCEKF100MC	C CHIP ELECTRO	MV 16V 10MF D4.0XH5.2
C72	HCFK104ZBA	C CHIP CERA	50V Y5V 0.1MF Z 1608
C73	HCFK104ZBA	C CHIP CERA	50V Y5V 0.1MF Z 1608
C74	HCFK104ZBA	C CHIP CERA	50V Y5V 0.1MF Z 1608
C75	HCFK104ZBA	C CHIP CERA	50V Y5V 0.1MF Z 1608
C76	HCFK104ZBA	C CHIP CERA	50V Y5V 0.1MF Z 1608
C77	HCFK104ZBA	C CHIP CERA	50V Y5V 0.1MF Z 1608
C78	HCFK104ZBA	C CHIP CERA	50V Y5V 0.1MF Z 1608
C8	HCBK102KBA	C CHIP CERA	50V X7R 1000PF K 1608
C801	CL1GB3334M	C LINE ACROSS	U/C/V/S/N/D/E/SV 250V
C802	CEYP2G680Z	C ELECTRO	400V SLT 68MF (25*20)
C803	CEXF1C101V	C ELECTRO	16V RSS 100MF (6.3X11) TP
C805	CEXF1H330V	C ELECTRO	50V RSS 33MF (6.3X11) TP
C807	CCYB3A103K	C CERA	1KV B 0.01MF K
C808	CCXF1H104Z	C CERA	50V F 0.1MF Z
C809	CEXF1H109V	C ELECTRO	50V RSS 1MF (5X11) TP
C81	HCEKF100MC	C CHIP ELECTRO	MV 16V 10MF D4.0XH5.2
C811	CMXM2A103J	C MYLAR	100V 0.01MF J (TP)
C812	CXSL3A470K	C CERA	1KV SL 47PF K (TP)
C813	CCXB1H681K	C CERA	50V B 680PF K (TAPPING)
C82	HCFK104ZBA	C CHIP CERA	50V Y5V 0.1MF Z 1608
C824	CH1FDF103M	C CERA AC	2.5KV 0.01MF M AC250V
C83	HCFK104ZBA	C CHIP CERA	50V Y5V 0.1MF Z 1608
C835	CEXF1E102V	C ELECTRO	25V RSS 1000MF (13X20) BK
C838	CEXF1C471V	C ELECTRO	16V RSS 470MF (10X12.5)BK
C84	HCFK104ZBA	C CHIP CERA	50V Y5V 0.1MF Z 1608
C843	CCXF1H104Z	C CERA	50V F 0.1MF Z
C844	CCXF1H104Z	C CERA	50V F 0.1MF Z
C845	CEXF1C102V	C ELECTRO	16V RSS 1000MF (10X20) TP
C848	CEXF1H109V	C ELECTRO	50V RSS 1MF (5X11) TP
C85	HCFK104ZBA	C CHIP CERA	50V Y5V 0.1MF Z 1608
C850	CEXF1C471V	C ELECTRO	16V RSS 470MF (10X12.5)BK
C851	CEXF1C471V	C ELECTRO	16V RSS 470MF (10X12.5)BK
C855	CEXF1C471V	C ELECTRO	16V RSS 470MF (10X12.5)BK
C859	CEXF1E101V	C ELECTRO	25V RSS 100MF (6.3X11) TP
C86	HCFK104ZBA	C CHIP CERA	50V Y5V 0.1MF Z 1608
C87	HCFK104ZBA	C CHIP CERA	50V Y5V 0.1MF Z 1608
C88	HCFK104ZBA	C CHIP CERA	50V Y5V 0.1MF Z 1608
C89	HCFK104ZBA	C CHIP CERA	50V Y5V 0.1MF Z 1608
C9	HCBK103KBA	C CHIP CERA	50V X7R 0.01MF K 1608
C90	HCFK104ZBA	C CHIP CERA	50V Y5V 0.1MF Z 1608
C91	HCFK104ZBA	C CHIP CERA	50V Y5V 0.1MF Z 1608
C92	HCFK104ZBA	C CHIP CERA	50V Y5V 0.1MF Z 1608
C93	HCEKF100MC	C CHIP ELECTRO	MV 16V 10MF D4.0XH5.2
C94	HCFK104ZBA	C CHIP CERA	50V Y5V 0.1MF Z 1608

LOC	PART-CODE	PART-NAME	PART-DESC
C96	HCEKF100MC	C CHIP ELECTRO	MV 16V 10MF D4.0XH5.2
C97	HCEKF100MC	C CHIP ELECTRO	MV 16V 10MF D4.0XH5.2
C98	HCEDC470MC	C CHIP ELECTRO	MV 6.3V 47MF 5DX5.2H
C99	HCEDC470MC	C CHIP ELECTRO	MV 6.3V 47MF 5DX5.2H
CN1	9979220119	CONN WAFER	YDW200-12
CN10	9979220013	CONN WAFER	SMW250-12
CN1A	99707C0013	CONN AS	SMH250+YDH200+2990=360
CN2	9979220118	CONN WAFER	YDW200-10
CN2A	99707A0024	CONN AS	35164+YDH200+2464#24=150
CN3	9979220117	CONN WAFER	YDW200-04
CN3A	9970740046	CONN AS	SMH250+YDH200+1007#24=330
CN4A	9970750037	CONN AS	5264+35164+2464#24=135
CN5	9979220148	CONN WAFER	FX8-80P-SV
CN6	9979200203	CONN WAFER	YW396-03AV
CN6A	9970720083	CONN AS	1015#18+35404-9002*4=120
CN7	9979200317	SOCKET AC INLET	ST-03B-BP
CN8	9979200209	D-SUB 15P ANGLE	15P DDC BLUE W/IN SCREW
CN9	9979220019	CONN WAFER	SMAW250-04 (ANGLE)
D1	DKDS226RTK	DIODE CHIP	KDS226(RTK)
D2	DKDS226RTK	DIODE CHIP	KDS226(RTK)
D3	DKDS226RTK	DIODE CHIP	KDS226(RTK)
D4	DKDS226RTK	DIODE CHIP	KDS226(RTK)
D5	DKDS226RTK	DIODE CHIP	KDS226(RTK)
D6	DKDS226RTK	DIODE CHIP	KDS226(RTK)
D7	DKDS226RTK	DIODE CHIP	KDS226(RTK)
D8	DRLS4148--	DIODE CHIP	RLS4148
D801	DD3SBA60--	DIODE	D3SBA60
D805	DZN4148---	DIODE	1N4148 AUTO 52MM
D807	DSUF4007SP	DIODE	SUF4007SP
D809	DUG2D-----	DIODE	UG2D 200V 2A
D811	DFMLG22S--	DIODE	FML-G22S
D812	DUG2D-----	DIODE	UG2D 200V 2A
D812A	DUG2D-----	DIODE	UG2D 200V 2A
D813	DFMBG19L--	DIODE	FMB-G19L
D9	DRLS4148--	DIODE CHIP	RLS4148
DZ12	DRLZ5R6B-B	DIODE CHIP ZENER	RLZTE-11 5.6B
DZ13	DRLZ5R6B-B	DIODE CHIP ZENER	RLZTE-11 5.6B
DZ803	DDZ22BM---	DIODE ZENER	DZ22BM
DZ806	DGDZJ18C--	DIODE ZENER	GDZJ 18C
DZ813	DDZ5R1B---	DIODE ZENER	DZ-5.1B
DZ814	DDZ5R1B---	DIODE ZENER	DZ-5.1B
DZ815	DDZ5R1B---	DIODE ZENER	DZ-5.1B
F801	5F3CB3122L	FUSE CERA	SEMKO TL 3.15AH 250V MF51
F801A	9977410900	FUSE CLIP	BSP3-H T0.4 SN 5.2
F801B	9977410900	FUSE CLIP	BSP3-H T0.4 SN 5.2
FB1	HFFTB2601B	COIL CHIP BEAD	TB321611Z260
FB10	HFFTB2601B	COIL CHIP BEAD	TB321611Z260
FB11	HFFTB2601B	COIL CHIP BEAD	TB321611Z260

LOC	PART-CODE	PART-NAME	PART-DESC
FB12	HFFTB2601B	COIL CHIP BEAD	TB321611Z260
FB13	HFFTB2601B	COIL CHIP BEAD	TB321611Z260
FB14	HFFTB2601B	COIL CHIP BEAD	TB321611Z260
FB15	HFFTB2601B	COIL CHIP BEAD	TB321611Z260
FB16	HFFTB2601B	COIL CHIP BEAD	TB321611Z260
FB17	HFFTB2601B	COIL CHIP BEAD	TB321611Z260
FB18	HFFTB2601B	COIL CHIP BEAD	TB321611Z260
FB19	HFFTB2601B	COIL CHIP BEAD	TB321611Z260
FB2	HFFTB2601B	COIL CHIP BEAD	TB321611Z260
FB20	HFFTB2601B	COIL CHIP BEAD	TB321611Z260
FB3	HFFTB2601B	COIL CHIP BEAD	TB321611Z260
FB4	HFFTB2601B	COIL CHIP BEAD	TB321611Z260
FB7	HFFTB2601B	COIL CHIP BEAD	TB321611Z260
FB8	HFFTB2601B	COIL CHIP BEAD	TB321611Z260
FB9	HFFTB2601B	COIL CHIP BEAD	TB321611Z260
IC801	1KA3842B--	IC POWER	KA3842B
IC802	1KA78R05--	IC REGULATOR	KA78R05
IC803	1KA278R33-	IC REGULATOR	KA278R33
IC804	1TLP721GR-	IC PHOTO COUPLER	TLP721D4GR
IC805	1KA431ZTA-	IC SHUNT	KA431ZTA
IC811	1KA78R05--	IC REGULATOR	KA78R05
INV1	DFL11501--	LCD INVERTER	FLI-1501
L801	5PDLF2323-	FILTER LINE	DLF-2323
L811	5MC0000003	COIL CHOKE	L-82
LCD	9979615042	LCD PANEL	L150X2M
LED1	DSD50GYW--	LED	SD50GYW(GREEN/AMBER)
PCB1	9979800571	PCB MAIN	T=1.6*138*100 (L510B1)
PCB2	9979800560	PCB POWER	T=1.6*162*102.5(L510B)
PCB3	9979800566	PCB CONTROL	T=1.6*246*122
Q1	TKTC3875SY	TR CHIP	KTC3875SY(RTK)
Q2	TKTC3875SY	TR CHIP	KTC3875SY(RTK)
Q3	TKTC3875SY	TR CHIP	KTC3875SY(RTK)
Q4	TKTC3875SY	TR CHIP	KTC3875SY(RTK)
Q5	TKTC3875SY	TR CHIP	KTC3875SY(RTK)
Q6	TNDS9958--	FET CHIP	NDS9958
Q801	TSSS6N70A-	FET	SSS6N70A
Q802	TZTC3198Y-	TR	KTC3198Y-(1815Y) (AUTO)
Q810	TZTC3202Y-	TR	KTC3202Y (AUTO)(1959Y)
R1	HRFS105JBA	R CHIP	1/16 1M OHM J 1608
R10	HRFS101JBA	R CHIP	1/16 100 OHM J 1608
R11	HRFS101JBA	R CHIP	1/16 100 OHM J 1608
R12	HRFS153JBA	R CHIP	1/16 15K OHM J 1608
R13	HRFS102JBA	R CHIP	1/16 1K OHM J 1608
R14	HRFS472JBA	R CHIP	1/16 4.7K OHM J 1608
R16	HRFS102JBA	R CHIP	1/16 1K OHM J 1608
R17	HRFS102JBA	R CHIP	1/16 1K OHM J 1608
R18	HRFS472JBA	R CHIP	1/16 4.7K OHM J 1608
R19	HRFS472JBA	R CHIP	1/16 4.7K OHM J 1608

LOC	PART-CODE	PART-NAME	PART-DESC
R2	HRFS472JBA	R CHIP	1/16 4.7K OHM J 1608
R20	HRFS472JBA	R CHIP	1/16 4.7K OHM J 1608
R21	HRFS472JBA	R CHIP	1/16 4.7K OHM J 1608
R22	HRFS472JBA	R CHIP	1/16 4.7K OHM J 1608
R23	HRFS472JBA	R CHIP	1/16 4.7K OHM J 1608
R24	HRFS472JBA	R CHIP	1/16 4.7K OHM J 1608
R25	HRFS472JBA	R CHIP	1/16 4.7K OHM J 1608
R26	HRFS472JBA	R CHIP	1/16 4.7K OHM J 1608
R29	HRFS220JBA	R CHIP	1/16W 22 OHM J 1608
R3	HRFS101JBA	R CHIP	1/16 100 OHM J 1608
R30	HRFS472JBA	R CHIP	1/16 4.7K OHM J 1608
R31	HRFS101JBA	R CHIP	1/16 100 OHM J 1608
R32	HRFS101JBA	R CHIP	1/16 100 OHM J 1608
R33	HRFS221JBA	R CHIP	1/16 220 OHM J 1608
R34	HRFS472JBA	R CHIP	1/16 4.7K OHM J 1608
R35	HRFS472JBA	R CHIP	1/16 4.7K OHM J 1608
R36	HRFS472JBA	R CHIP	1/16 4.7K OHM J 1608
R37	HRFS221JBA	R CHIP	1/16 220 OHM J 1608
R38	HRFS472JBA	R CHIP	1/16 4.7K OHM J 1608
R39	HRFS472JBA	R CHIP	1/16 4.7K OHM J 1608
R4	HRFS223JBA	R CHIP	1/16 22K OHM J 1608
R40	HRFS102JBA	R CHIP	1/16 1K OHM J 1608
R41	HRFS102JBA	R CHIP	1/16 1K OHM J 1608
R42	HRFS472JBA	R CHIP	1/16 4.7K OHM J 1608
R43	HRFS101JBA	R CHIP	1/16 100 OHM J 1608
R44	HRFS101JBA	R CHIP	1/16 100 OHM J 1608
R45	HRFS000JBA	R CHIP	1/16 0 OHM J 1608
R46	HRFS472JBA	R CHIP	1/16 4.7K OHM J 1608
R47	HRFS750JBA	R CHIP	1/16W 75 OHM J 1608
R48	HRFS750JBA	R CHIP	1/16W 75 OHM J 1608
R49	HRFS750JBA	R CHIP	1/16W 75 OHM J 1608
R50	HRFS101JBA	R CHIP	1/16 100 OHM J 1608
R51	HRFS101JBA	R CHIP	1/16 100 OHM J 1608
R52	HRFS472JBA	R CHIP	1/16 4.7K OHM J 1608
R53	HRFS472JBA	R CHIP	1/16 4.7K OHM J 1608
R54	HRFS512JBA	R CHIP	1/16 5.1K OHM J 1608
R56	HRFS472JBA	R CHIP	1/16 4.7K OHM J 1608
R57	HRFS472JBA	R CHIP	1/16 4.7K OHM J 1608
R58	HRFS472JBA	R CHIP	1/16 4.7K OHM J 1608
R59	HRFS472JBA	R CHIP	1/16 4.7K OHM J 1608
R60	HRFS472JBA	R CHIP	1/16 4.7K OHM J 1608
R61	HRFS472JBA	R CHIP	1/16 4.7K OHM J 1608
R63	HRFS105JBA	R CHIP	1/16 1M OHM J 1608
R64	HRFS102JBA	R CHIP	1/16 1K OHM J 1608
R65	HRFS102JBA	R CHIP	1/16 1K OHM J 1608
R66	HRFS102JBA	R CHIP	1/16 1K OHM J 1608
R67	HRFS220JBA	R CHIP	1/16W 22 OHM J 1608
R68	HRFS472JBA	R CHIP	1/16 4.7K OHM J 1608

LOC	PART-CODE	PART-NAME	PART-DESC
R69	HRFS472JBA	R CHIP	1/16 4.7K OHM J 1608
R72	HRFS102JBA	R CHIP	1/16 1K OHM J 1608
R73	HRFS102JBA	R CHIP	1/16 1K OHM J 1608
R80	RD-AZ302J-	R CARBON FILM	1/6 3K OHM J
R801	RD-2Z684J-	R CARBON FILM	1/2 680K OHM J
R803	RS01Z513J-	R M-OXIDE FILM	1W 51K OHM J
R804	RS01Z513J-	R M-OXIDE FILM	1W 51K OHM J
R805	RD-AZ102J-	R CARBON FILM	1/6 1K OHM J
R806	RD-AZ333J-	R CARBON FILM	1/6 33K OHM J
R807	RN-AZ2001F	R METAL FILM	1/6 2.0K OHM F
R809	RS01Z683J-	R M-OXIDE FILM	1W 68K OHM J (TAPPING)
R81	RD-AZ682J-	R CARBON FILM	1/6 6.8K OHM J
R812	RD-AZ470J-	R CARBON FILM	1/6 47 OHM J
R813	RD-AZ223J-	R CARBON FILM	1/6 22K OHM J
R814	RD-AZ102J-	R CARBON FILM	1/6 1K OHM J
R815	RW01Z758JN	R WIRE WOUND	1W 0.75 OHM J NON-INDUCT
R82	RD-AZ153J-	R CARBON FILM	1/6 15K OHM J
R820	RD-AZ180J-	R CARBON FILM	1/6 18 OHM J
R822	RD-AZ681J-	R CARBON FILM	1/6 680 OHM J
R825	RD-AZ479J-	R CARBON FILM	1/6 4.7 OHM J
R826	RD-AZ333J-	R CARBON FILM	1/6 33K OHM J
R827	RD-AZ151J-	R CARBON FILM	1/6 150 OHM J
R83	RD-AZ303J-	R CARBON FILM	1/6 30K OHM J
R832	RD-AZ102J-	R CARBON FILM	1/6 1K OHM J
R837	RD-AZ102J-	R CARBON FILM	1/6 1K OHM J
R839	RN-AZ1002F	R METAL FILM	1/6 10K OHM F
R84	RD-AZ623J-	R CARBON FILM	1/6 62K OHM J
R840	RN-AZ6651F	R METAL FILM	1/6 6.65K OHM F
R841	RD-AZ102J-	R CARBON FILM	1/6 1K OHM J
R854	RD-AZ102J-	R CARBON FILM	1/6 1K OHM J
R855	RD-4Z512J-	R CARBON FILM	1/4 5.1K OHM J
RP1	HFFH4M301E	COIL CHIP BEAD	HB-4M3216-301JT
RP10	HFFH4M301E	COIL CHIP BEAD	HB-4M3216-301JT

LOC	PART-CODE	PART-NAME	PART-DESC
RP14	HRTS8E220J	R CHIP ARRAY	1/16 8P 22 OHM J 3216
RP15	HRTS8E220J	R CHIP ARRAY	1/16 8P 22 OHM J 3216
RP16	HRTS8E220J	R CHIP ARRAY	1/16 8P 22 OHM J 3216
RP17	HRTS8E220J	R CHIP ARRAY	1/16 8P 22 OHM J 3216
RP18	HRTS8E220J	R CHIP ARRAY	1/16 8P 22 OHM J 3216
RP19	HRTS8E220J	R CHIP ARRAY	1/16 8P 22 OHM J 3216
RP2	HFFH4M301E	COIL CHIP BEAD	HB-4M3216-301JT
RP3	HFFH4M301E	COIL CHIP BEAD	HB-4M3216-301JT
RP4	HFFH4M301E	COIL CHIP BEAD	HB-4M3216-301JT
RP5	HFFH4M301E	COIL CHIP BEAD	HB-4M3216-301JT
RP6	HFFH4M301E	COIL CHIP BEAD	HB-4M3216-301JT
RP7	HFFH4M301E	COIL CHIP BEAD	HB-4M3216-301JT
RP8	HFFH4M301E	COIL CHIP BEAD	HB-4M3216-301JT
RP9	HFFH4M301E	COIL CHIP BEAD	HB-4M3216-301JT
SW1	5S50101Z10	SW TACT	KPT-1115AM
SW2	5S50101Z10	SW TACT	KPT-1115AM
SW3	5S50101Z10	SW TACT	KPT-1115AM
SW4	5S50101Z10	SW TACT	KPT-1115AM
SW5	5S50101Z10	SW TACT	KPT-1115AM
SW6	5S50101Z10	SW TACT	KPT-1115AM
T801	5RM0000111	TRANS SMPS	DMT-510B
TH801	DTP8D13---	THERMISTOR	TP8D13
U1	1AS1320---	IC LCD CONTROLLER	AS1320
U2	1TDA8752BH	IC ADC	TDA8752BH/8
U3	1MTV212MV-	IC MICOM	MTV212MV64I
U3S	9979300502	SOCKET IC	PLCC 1.27PT 44PIN(22*22)
U4	1CAT24WC08	IC EEPROM	CAT24WC08 J
U5	174ACT14SC	IC INVERTER	74ACT14SCX
U6	1K1A7042AF	IC RESET	KIA7042AF
U7	1LM385M25-	IC VOLTAGE REFERENCE	LM385M25
Y1	5XS14R318F	CRYSTAL QUARTZ	HC-49/SM5H 14.318MHZ 18PF
Y2	5XJ12R000E	CRYSTAL QUARTZ	HC-49/S 12.00000MHZ 30PPM

DAEWOO

DAEWOO ELECTRONICS CO., LTD

686, AHYEON-DONG MAPO-GU
SEOUL, KOREA

C.P.O. BOX 8003 SEOUL, KOREA

TELEX : DWELEC K28177-8

CABLE : "DAEWOOELEC"

Free Manuals Download Website

<http://myh66.com>

<http://usermanuals.us>

<http://www.somanuals.com>

<http://www.4manuals.cc>

<http://www.manual-lib.com>

<http://www.404manual.com>

<http://www.luxmanual.com>

<http://aubethermostatmanual.com>

Golf course search by state

<http://golfingnear.com>

Email search by domain

<http://emailbydomain.com>

Auto manuals search

<http://auto.somanuals.com>

TV manuals search

<http://tv.somanuals.com>