

DAEWOO

Service Manual

Microwave Oven

Model: KOR-63DB9S

KOR-63DB0S

KOR-63FB9S

KOR-63FB0S

✓ **Caution**

: In this Manual, some parts can be changed for improving, their performance without notice in the parts list. So, if you need the latest parts information, please refer to PPL(Parts Price List) in Service Information Center (<http://svc.dwe.co.kr>).



DAEWOO ELECTRONICS CO., LTD.

PRECAUTIONS TO BE OBSERVED BEFORE AND DURING SERVICING TO AVOID POSSIBLE EXPOSURE TO EXCESSIVE MICROWAVE ENERGY

- (a) Do not operate or allow the oven to be operated with the door open.
- (b) Make the following safety checks on all ovens to be serviced before activating the magnetron or other microwave source, and make repairs as necessary: (1) Interlock operation, (2) Proper door closing, (3) Seal and sealing surfaces (arcing, wear, and other damage), (4) Damage to or loosening of hinges and latches, (5) Evidence of dropping or abuse.
- (c) Before turning on power to the microwave oven for any service test or inspection within the microwave generating compartments, check the magnetron, wave guide or transmission line, and cavity for proper alignment, integrity, and connections.
- (d) Any defective or misadjusted components in the interlock, monitor, door seal, and microwave generation and transmission systems shall be repaired, replaced, or adjusted by procedures described in this manual before the oven is released to the owner.
- (e) A microwave leakage check to verify compliance with the Federal performance standard should be performed on each oven prior to release to the owner.

TABLE OF CONTENTS

SAFETY AND PRECAUTIONS	2
1. FOR SAFE OPERATION	2
2. FOR SAFE SERVICE PROCEDURES	2
SPECIFICATIONS	3
EXTERNAL VIEW	4
1. OUTER DIMENSION	4
2. FEATURE DIAGRAM	5
3. CONTROL PANEL	6
INSTALLATION	7
OPERATIONS AND FUNCTIONS	8
DISASSEMBLY AND ASSEMBLY	9
INTERLOCK MECHANISM AND ADJUSTMENT	16
TROUBLE SHOOTING GUIDE	17
MEASUREMENT AND TEST	21
1. MEASUREMENT OF THE MICROWAVE POWER OUTPUT	21
2. MICROWAVE RADIATION TEST	22
3. COMPONENT TEST PROCEDURE	23
WIRING DIAGRAM	24
PRINTED CIRCUIT BOARD	25
1. CIRCUIT CHECK PROCEDURE	25
2. PCB CIRCUIT DIAGRAM	28
3. P.C.B. LOCATION NO	29
EXPLODED VIEW AND PARTS LIST	30
1. DOOR ASSEMBLY	30
2. CONTROL PANEL ASSEMBLY	30
3. TOTAL ASSEMBLY	30

SAFETY AND PRECAUTIONS

1. FOR SAFE OPERATION

Damage that allows the microwave energy (that cooks or heats the food) to escape will result in poor cooking and may cause serious bodily injury to the operator.

IF ANY OF THE FOLLOWING CONDITIONS EXIST, OPERATOR MUST NOT USE THE APPLIANCE.

(Only a trained service personnel should make repairs.)

- (1) A broken door hinge.
- (2) A broken door viewing screen.
- (3) A broken front panel, oven cavity.
- (4) A loosened door lock.
- (5) A broken door lock.

The door gasket plate and oven cavity surface should be kept clean.

No grease, soil or spatter should be allowed to build up on these surfaces or inside the oven.

DO NOT ATTEMPT TO OPERATE THIS APPLIANCE WITH THE DOOR OPEN.

The microwave oven has concealed switches to make sure the power is turned off when the door is opened.

Do not attempt to defeat them.

DO NOT ATTEMPT TO SERVICE THIS APPLIANCE UNTIL YOU HAVE READ THIS SERVICE MANUAL.

2. FOR SAFE SERVICE PROCEDURES

1. If the oven is operative prior to servicing, a microwave emission check should be performed prior to servicing the oven.
2. If any certified oven unit is found to servicing, a microwave emission check should be performed prior to servicing the oven.
 - (a) inform the manufacturer, importer or assembler,
 - (b) repair the unit at no cost to the owner,
 - (c) attempt to ascertain the cause of the excessive leakage,
 - (d) tell the owner of the unit not to use the unit until the oven has been brought into compliance.
3. If the oven operates with the door open, the service person should tell the user not to operate the oven and contact the manufacturer and CDRH immediately.

IMPORTANT

The wire in this mains lead coloured in accordance with the following code.

Green-and-yellow : Earth
Blue : Neutral
Brown : Live

As the colours of the wires in the mains lead of this appliance may not correspond with the coloured markings identifying the terminals in your plug, proceed as follows.

The wire which is coloured green-and-yellow must be connected to the terminal in the plug which is marked with the letter 'E', earth symbol or coloured green-and-yellow.

The wire which is coloured blue must be connected to the terminal which is marked with the letter 'N' or coloured black.

The wire which is coloured brown must be connected to the terminal which is marked with the letter 'L' or coloured red.

NOTE

This oven is designed for counter-top use only.

SPECIFICATIONS

MODEL		KOR-63DB9S	KOR-63DB0S
POWER SUPPLY		230V-50Hz, SINGLE PHASE WITH EARTHING	
POWER CONSUMPTION	MICROWAVE	1000W	1200W
	GRILL		
	COMBINATION		
MICROWAVE ENERGY OUTPUT		700W	800W
MICROWAVE FREQUENCY		2450MHz	
OUTSIDE DIMENSIONS (W X H X D)		465 x 279 x 342 mm (18.3 x 11.0 x 13.5 in)	
CAVITY DIMENSIONS (W X H X D)		290 x 220 x 306 mm (11.4 x 8.7 x 12.0 in)	
NET WEIGHT		APPROX. 13 kg (28.7 lbs.)	
TIMER		59 min. 90 sec.	
FUNCTION SELECTIONS		MICROWAVE	
POWER SELECTIONS		10 LEVELS	
CAVITY VOLUME		0.7 Cu. Ft.	

* SPECIFICATIONS ARE SUBJECT TO CHANGE WITHOUT NOTICE.

MODEL		KOR-63FB9S	KOR-63FB0S
POWER SUPPLY		230V-50Hz, SINGLE PHASE WITH EARTHING	
POWER CONSUMPTION	MICROWAVE	1000W	1200W
	GRILL		
	COMBINATION		
MICROWAVE ENERGY OUTPUT		700W	800W
MICROWAVE FREQUENCY		2450MHz	
OUTSIDE DIMENSIONS (W X H X D)		465 x 279 x 349 mm (18.3 x 11.0 x 13.8 in)	
CAVITY DIMENSIONS (W X H X D)		290 x 220 x 306 mm (11.4 x 8.7 x 12.0 in)	
NET WEIGHT		APPROX. 13 kg (28.7 lbs.)	
TIMER		59 min. 90 sec.	
FUNCTION SELECTIONS		MICROWAVE	
POWER SELECTIONS		10 LEVELS	
CAVITY VOLUME		0.7 Cu. Ft.	

* SPECIFICATIONS ARE SUBJECT TO CHANGE WITHOUT NOTICE.

EXTERNAL VIEW

1. OUTER DIMENSION

(1) KOR-63DB9S/63DB0S

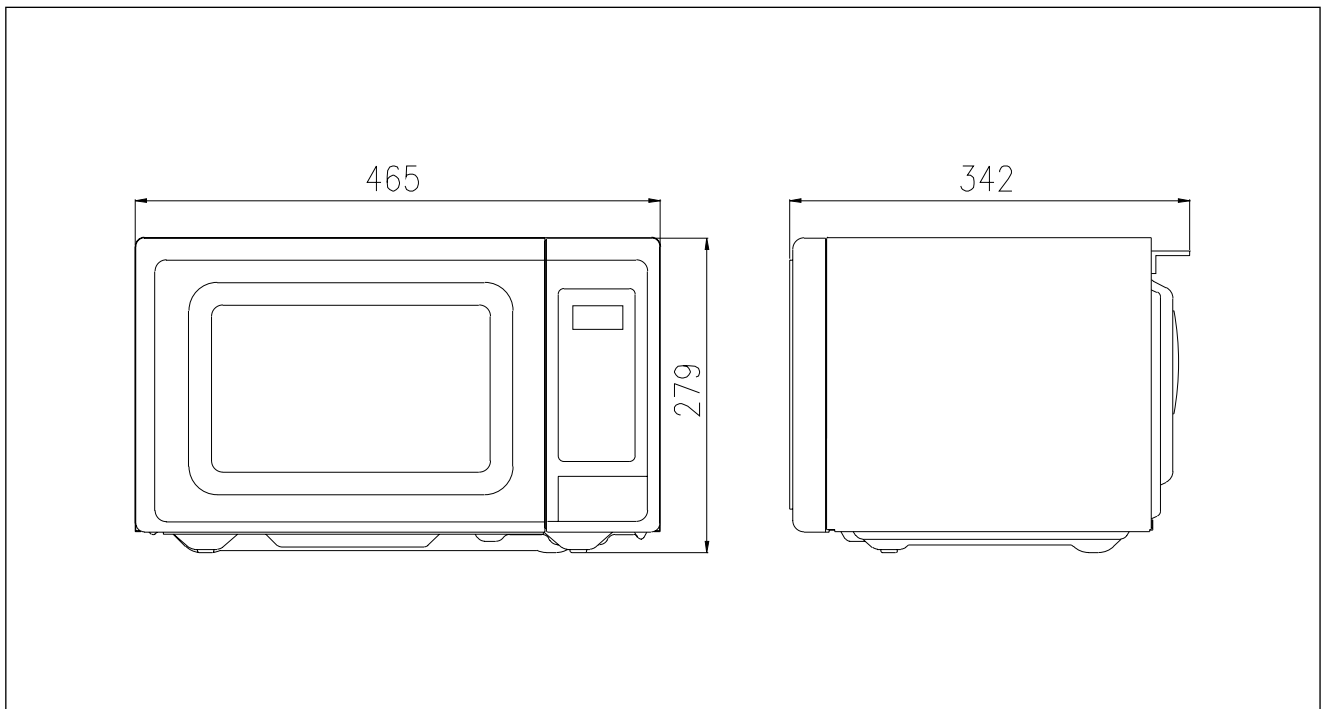

(2) KOR-63FB9S/63FB0S

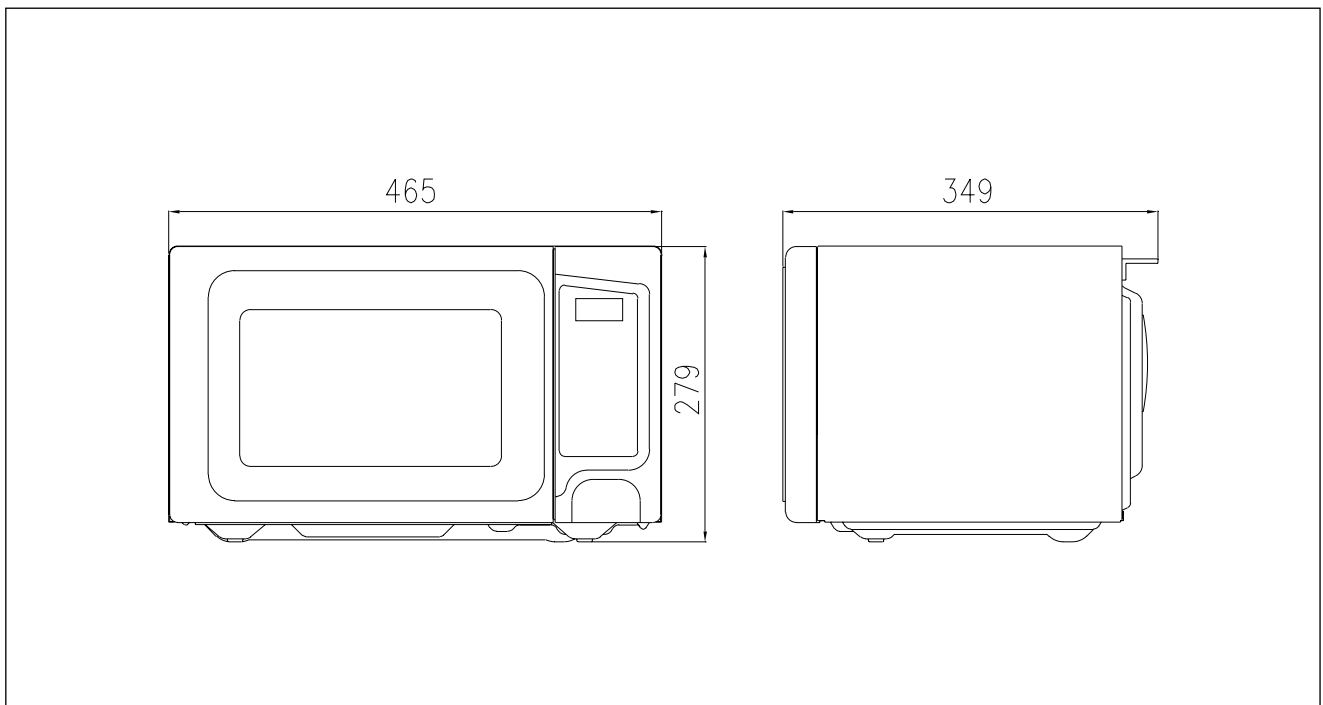

2. FEATURE DIAGRAM

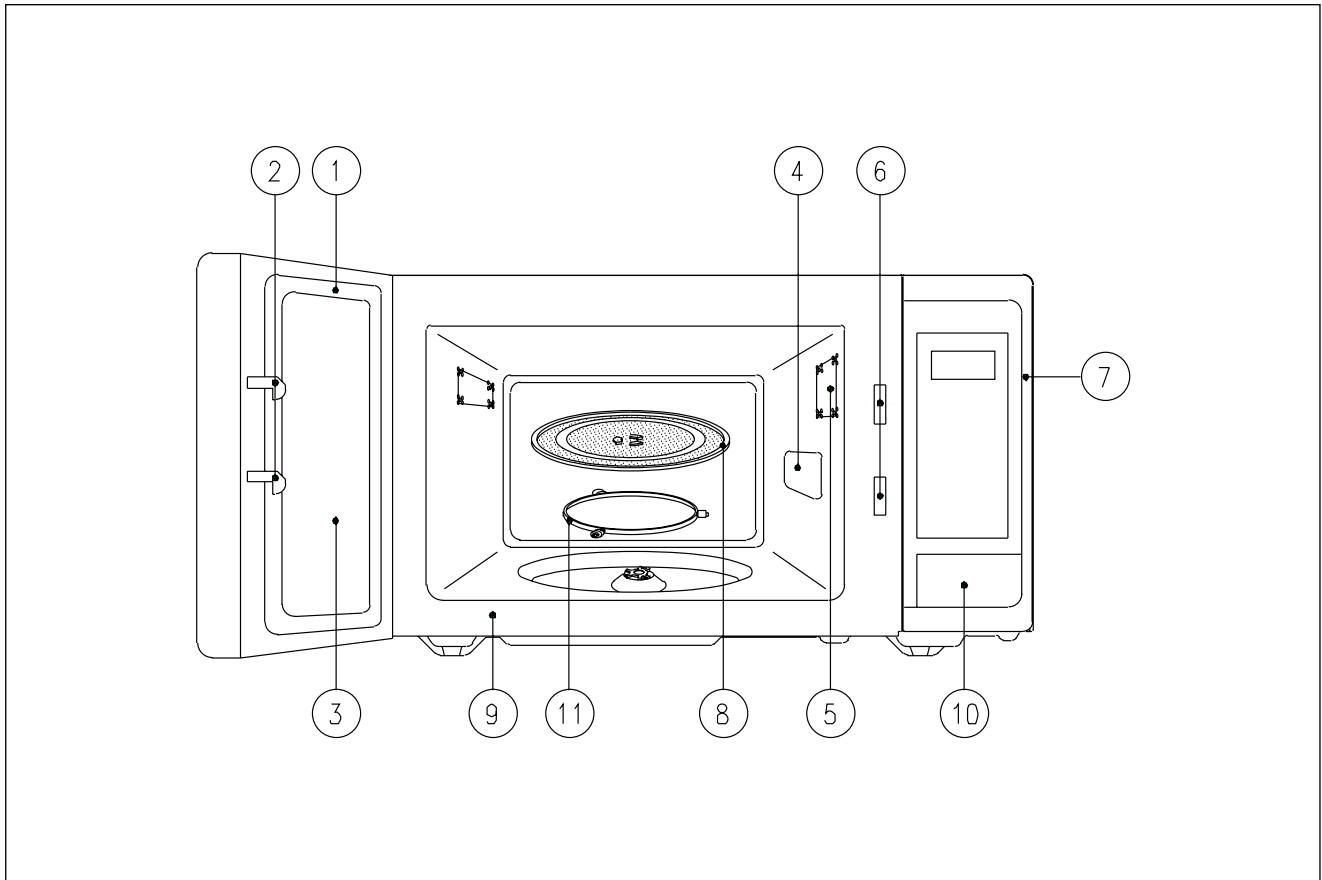

- 1. DOOR SEAL**
Door seal maintains the microwave within the oven cavity and prevents microwave leakage.
- 2. DOOR HOOK**
When the door is closed, it will automatically lock shut. If door is opened while oven is operating, magnetron tube will immediately stop operating.
- 3. DOOR SCREEN**
Allows viewing of food. Microwave cannot pass through perforations in screen.
- 4. SPATTER SHIELD**
Protects the microwave outlet from splashes of cooking foods.
- 5. OVEN LAMP**
Automatically turns on during oven operating.
- 6. SAFETY INTERLOCK SYSTEM**
- 7. CONTROL PANEL**
- 8. GLASS COOKING TRAY**
Made of special heat resistant glass. The tray must always be in proper position before operating. Do not cook food directly on the tray.
- 9. OVEN FRONT PLATE**
- 10. DOOR OPENING BUTTON**
To open the door push the door opening button. When door is closed, it will automatically lock shut. If door is opened while oven is operating, magnetron tube will immediately stop operating.
- 11. ROLLER GUIDE**
Supports the glass cooling tray.

3. CONTROL PANEL

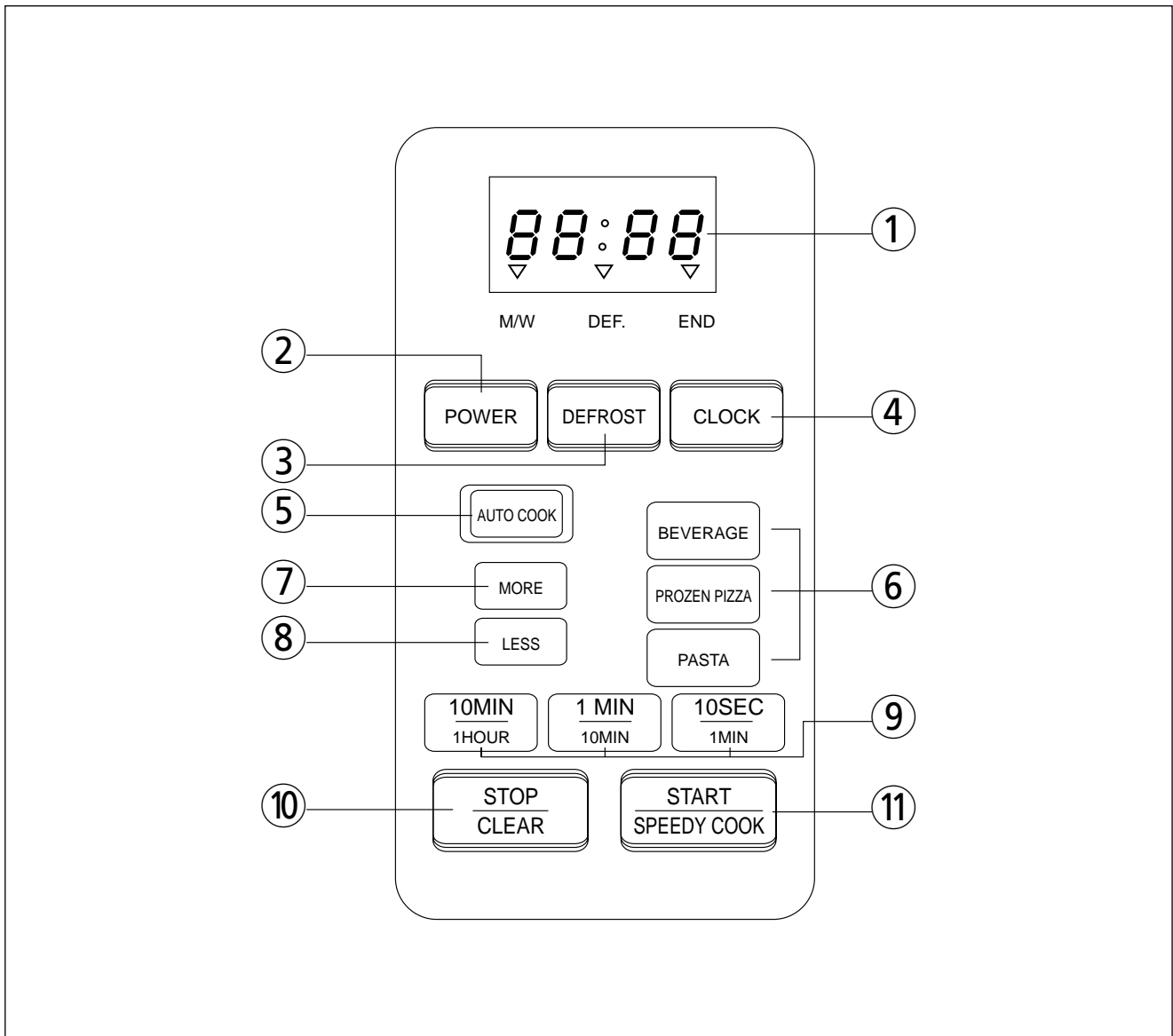

1. **Display** – Cooking time, power level, indicators and present time are displayed.
2. **Power** – Used to set power level.
3. **Defrost** – Used to defrost foods. (for time)
4. **Clock** – Used to set clock.
5. **Auto cook** – Used to cook or reheat.
6. **One touch** – Used to cook or reheat specific quantities of food.
7. **More** – Used to add time to cooking.
8. **Less** – Used to remove time from cooking.
9. **Time set pad** – Used to set the cooking time and the present time.
10. **Stop/Clear** – Used to stop the oven operation or to delete the cooking data.
11. **Start/Speedy cook** – Used to start the oven and also used to set a reheat time.

INSTALLATION

1. Steady, flat location.

This microwave oven should be set on a steady, flat surface.

This microwave oven is designed for counter top use only.

2. Leave space behind and side.

All air vents should be kept a clearance. If all vents are covered during operation, the oven may overheat and, eventually, cause failure.

3. Away from radio, and TV sets

Poor television reception and radio interference may result if the oven is located close to a TV, radio, antenna, or feeder and so on. Position the oven as far from them as possible.

4. Away from heating appliances and water taps

Keep the oven away from hot air, steam or splash when choosing a place to position it, or the insulation might be adversely affected and breakdowns occur.

5. Power supply

- Check your local power source.
This microwave oven requires a current of approximately 6 amperes, 230 Volts, 50 Hz.
- Power supply cord is about 0.8 meters long.
- The voltage used must be the same as specified on this oven. Using a higher voltage may result in a fire or other accident causing oven damage. Using low voltage will cause slow cooking. We are not responsible for damage resulting from use of this oven with a voltage of ampere fuse other than those specified.
- This appliance is supplied with cable of special type, which, if damaged, must be repaired with cable of same type.
Such a cable can be purchased from DAEWOO and must be installed by a Qualified Person.

6. Examine the oven after unpacking for any damage such as:

A misaligned door, broken door or a dent in cavity.

If any of the above are visible, DO NOT INSTALL, and notify dealer immediately.

7. Do not operate the oven if it is colder than room temperature

(This may occur during delivery in cold weather.) Allow the oven to become room temperature before operating.

EARTHING INSTRUCTIONS

This appliance must be earthed. In the event of an electrical short circuit, earthing reduces the risk of the electric shock by providing an escape wire for the electric current. This appliance is equipped with a cord having a earthing plug. The plug must be plugged into an outlet that is properly installed and earthed.

WARNING

Improper use of the earthing plug can result in a risk of electric shock. Consult a qualified electrician or service-man if the earthing instructions are not completely understood, or if doubt exists as to whether the appliance is properly earthed, and either : If it is necessary to use an extension cord, use only a 3-wire extension cord that has a 3-blade earthing plug, and a 3-slot receptacle that will accept the plug on the appliance. The marked rating of the extension cord should be equal to or greater than the electrical rating of the appliance, or Do not use an extension cord.

OPERATIONS AND FUNCTIONS

1. Connect the main lead to an electrical outlet.
2. After placing the food in a suitable container, open the oven door and put it on the glass tray. The glass tray must always be in place during cooking.
3. Close the door securely.
4. When the oven door is opened, the light turns ON.
5. The oven door can be opened at any time during operation.
The oven will automatically shut off. To restart the oven, close the door and then touch START.
6. The oven automatically cook on full power unless set to a lower power level.
7. The display will show : 0 when the oven is plugged in.
8. Time clock returns to the present time when the cooking time ends.
9. When the CANCEL button is touched during the oven operation, the oven stops cooking and all information retained.
To erase all information (except the present time), touch the CANCEL button once more. If the oven door is opened during the oven operation, all information is retained.
10. If the START button is touched and the oven does not operate, check the area between the door and door is closed securely. The oven will not start cooking under the door is completely closed or the program has been reset.

Make sure the oven is properly installed and plugged into the electrical.

Wattage output chart

The power level is set by pressing the POWER button. The chart shows the display, the power level and the percentage of power.

Touch POWER button	Power level(Display)	Approximate Percentage of Power
Once	P-HI	100%
Twice	P-90	90%
3 times	P-80	80%
4 times	P-70	70%
5 times	P-60	60%
6 times	P-50	50%
7 times	P-40	40%
8 times	P-30	30%
9 times	P-20	20%
10 times	P-10	10%
11 times	P-00	0%

DISASSEMBLY AND ASSEMBLY

Cautions to be observed when trouble shooting.

Unlike many other appliances, the microwave oven is high-voltage, high-current equipment.

It is completely safe during normal operation.

However, carelessness in servicing the oven can result in an electric shock or possible danger from a short circuit.

You are asked to observe the following precautions carefully.

1. Always remove the power plug from the outlet before servicing.
2. Use an insulated screwdriver and wear rubber gloves when servicing the high voltage side.
3. Discharge the high voltage capacitor before touching any oven components or wiring.

(1) Check the grounding.

Do not operate on a two-wire extension cord.

The microwave oven is designed to be used while earthed.

It is imperative, therefore, to make sure it is earthed properly before beginning repair work.

(2) Warning about the electric charge in the high voltage capacitor.

For about 30 seconds after the operation stopped and electric charge remains in the high voltage capacitor.

When replacing or checking parts, short between oven chassis and the negative high terminal of the high voltage capacitor by using a properly insulated screwdriver to discharge.

4. When the 15A fuse is blown out due to the operation of the monitor switch; replace primary interlock switch, secondary interlock switch and interlock monitor switch.
5. After repair or replacement of parts, make sure that the screws are properly tightened, and all electrical connections are tightened.
6. Do not operate without cabinet.

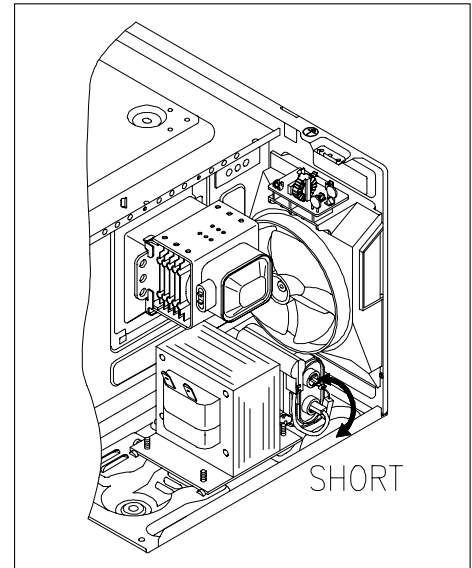

CAUTION : Service personnel should remove their watches whenever working close to or replacing the magnetron.

WARNING : When servicing the appliance, need a care of touching or replacing high potential parts because of electrical shock or exposing microwave. These parts are as follows - HV Transformer, Magnetron, HV Capacitor, HV Diode, HV fuse.

1. To remove cabinet

- 1) Remove three screws on cabinet back.
- 2) Push the cabinet backward.

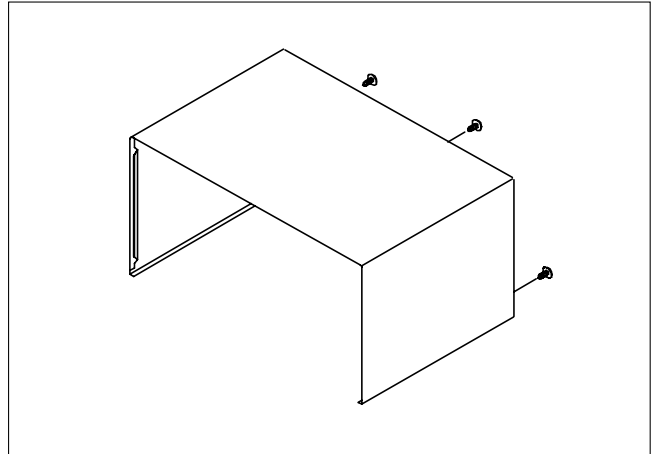

2. To remove door assembly

- 1) Remove two screws which secure the stopper hinge top.
- 2) Remove the door assembly from top plate of cavity.
- 3) Reverse the above for reassembly.

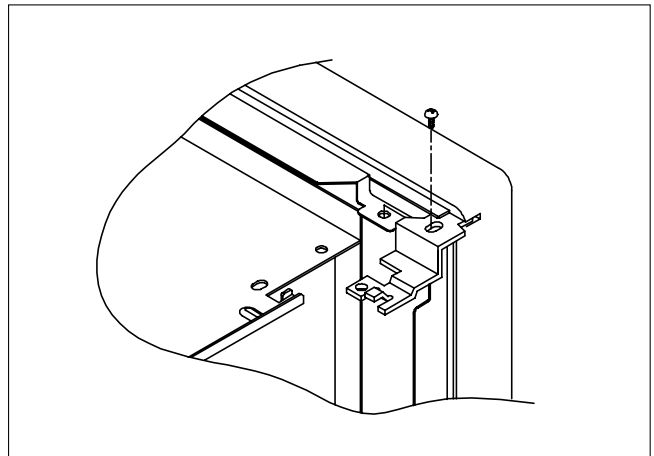

NOTE : After replacing the door assembly, perform a check of correct alignment with the hinge and cavity front plate.

✓ **Caution:** In this Service Manual, some parts can be changed for improving, their performance without notice in the parts list. So, if you need the latest parts information, please refer to PPL(Parts Price List) in Service information Center(<http://svc.dwe.co.kr>)

3. To remove door parts.

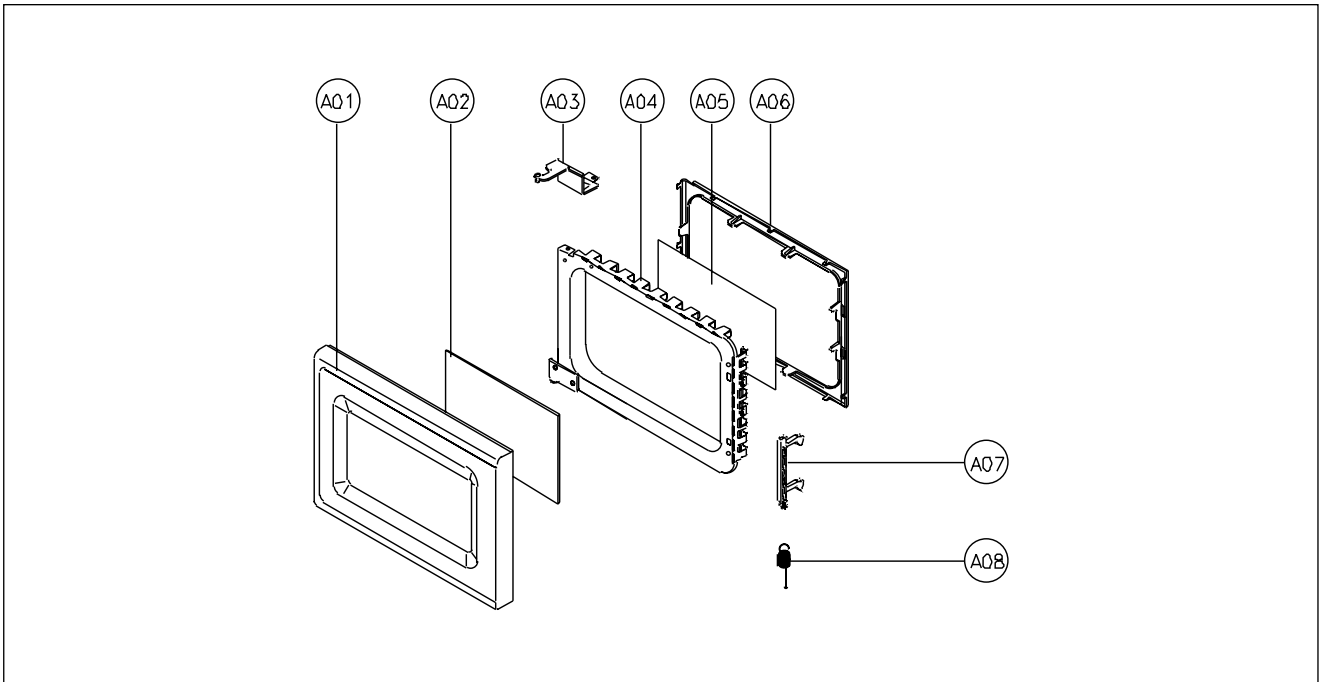

REF NO.	PART CODE	PART NAME	DESCRIPTION	Q'TY	REMARK
A01	3512203880	FRAME DOOR	PP SI83C	1	KOR-63DB
	3512205200	FRAME DOOR	PP SI83C	1	KOR-63FB
A02	3517007300	BARRIER-SCREEN*0	PET T0.125	1	
A03	3515204100	STOPPER SINGE *T AS	KOR-63150S	1	
A04	3511705500	DOOR WELD AS	KOR-61150S	1	
A05	3517002800	BARRIER-SCREEN *1	T0.1	1	
A06	3512300200	GASKET DOOR	PP	1	
A07	3513100700	HOOK	POM	1	
A08	3515101300	SPRING HOOK	PW -1	1	

-
- (1) Remove the gasket door from door weld as.
 - (2) Remove the door frame from door weld as.
 - (3) Remove the stopper hinge top from door weld as.
 - (4) Remove the spring and the hook.
 - (5) Remove the barrier screen outer from door frame.
 - (6) Reverse the above steps for reassembly.

4. Method to reduce the gap between the door seal and the oven front surface.

- (1) To reduce gap located on part 'A'
Loosen a screws on stopper hinge top, and then push the door to contact the door seal to oven front surface.
Tighten two screws.
- (2) To reduce gap located on part 'B'
Loosen two screws on stopper hinge under, and then push the door to contact the door seal to oven front surface.
Tighten two screws.

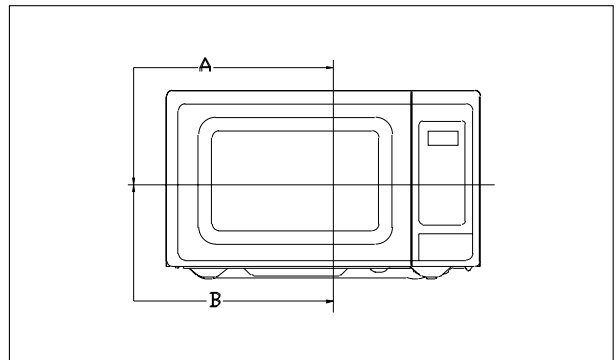

NOTE : A small gap may be acceptable if the microwave leakage does not exceed $4\text{mW}/\text{cm}^2$.

✓ **Caution:** In this Service Manual, some parts can be changed for improving, their performance without notice in the parts list. So, if you need the latest parts information, please refer to PPL(Parts Price List) in Service information Center(<http://svc.dwe.co.kr>)

5. To remove control panel parts.

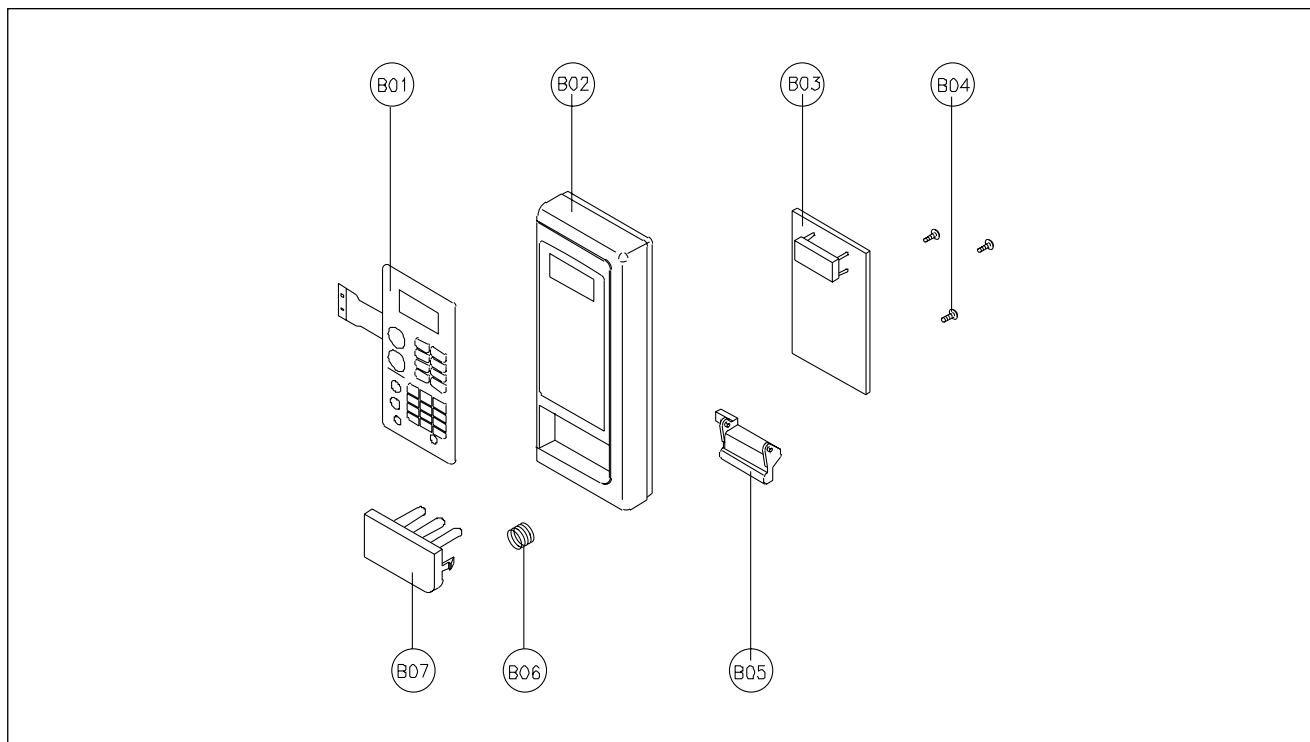

REF NO.	PART CODE	PART NAME	DESCRIPTION	Q'TY	REMARK
B01	3518520960	SWITCH MEMBREANE	KOR-63DB9S	1	KOR-63DB
	3518520970	SWITCH MEMBRANE	KOR-63FB9S	1	KOR-63FB
B02	3516725300	CONTROL PANEL	ABS SG-0760D, SG-175	1	KOR-63DB
	3516725350	CONTROL PANEL	ABS SG-0760D, SG-175	1	KOR-63FB
B03	3514320670	PCB AS	KOR-63DB9S	1	
B04	7122401211	SCREW TAPPING	T2S TRS 4X12 MFZN	3	
B05	3513702710	LEVER DOOR OPEN	PP	1	
B06	441G430171	SPRING BUTTON	SWP DIA0.7	1	
B07	3516906940	BUTTON DOOR OPEN	ABS SG-0760D, SG-175	1	KOR-63DB
	3516906950	BUTTON DOOR OPEN	ABS SG-0760D, SG-175	1	KOR-63FB

- 1) Remove the screw which secure the control panel, push up two snap fits and draw forward the control panel assembly.
- 2) Remove the door open lever from the control panel.
- 3) Remove four screws which secure the PCB assembly to control panel.
- 4) Disconnect membrane tail from the connector of the PCB assembly.
- 5) Detach membrane from the control panel.
- 6) Remove door open button and button spring from the control panel.
- 7) Reverse the above steps for reassembly.

6. To remove high voltage capacitor.

- 1) Remove a screw which secure the grounding ring terminal of the H.V. diode and the capacitor holder.
- 2) Remove the H.V. diode from the capacitor holder.
- 3) Reverse the above steps for reassembly.

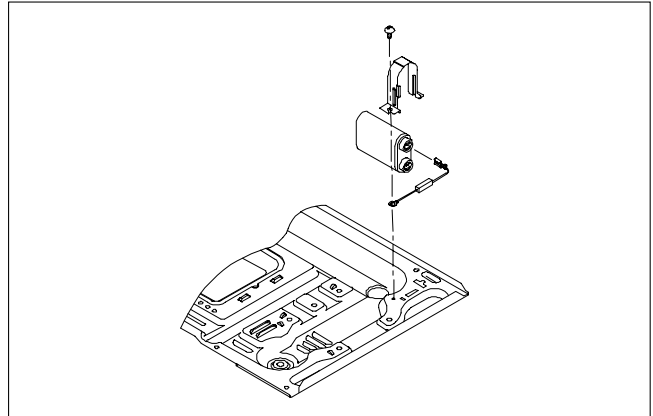

◆ High voltage circuit wiring

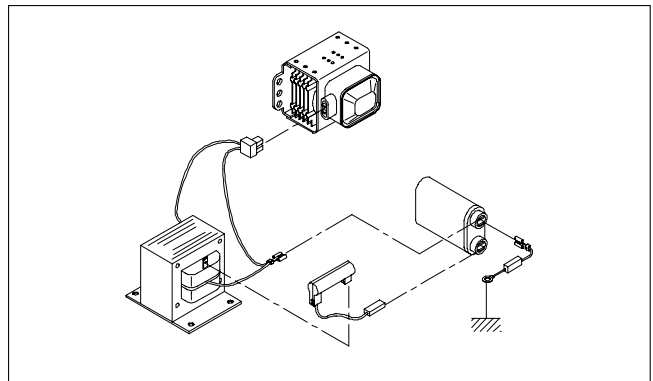

7. To remove magnetron.

- 1) Remove a screw which secure the magnetron.
- 2) Remove the magnetron.
- 3) Reverse the above steps for reassembly.

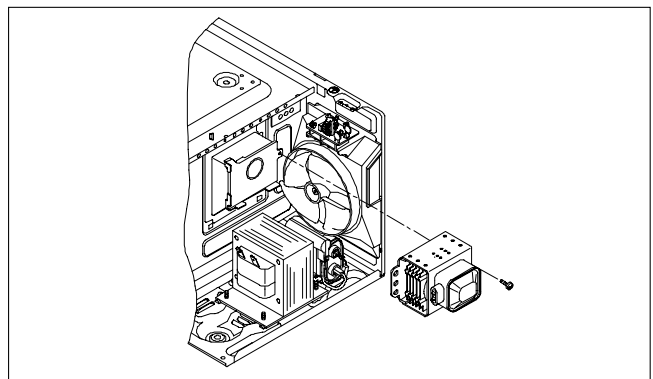

NOTE : Never install the magnetron without the metallic gasket plate which is packed with each magnetron to prevent microwave leakage. Whenever repair work is carried out on magnetron, check the microwave leakage. It shall not exceed 4mW/cm² for a fully assembled oven with door normally closed.

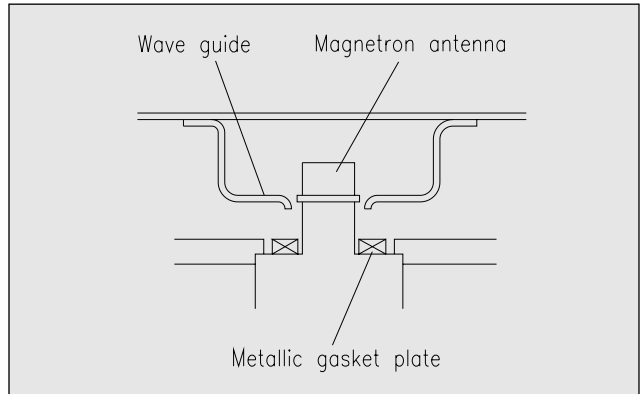
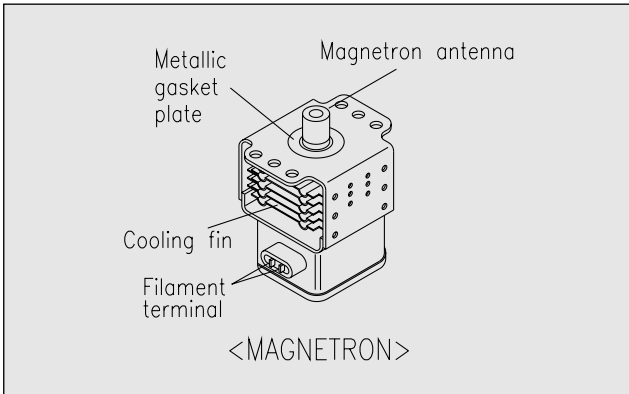

8. To remove wind guide assembly.

- 1) Remove a screw for earthing.
- 2) Remove the noise filter from the wind guide.
- 3) Remove a screw which secure the wind guide assembly.
- 4) Draw forward the wind guide assembly.
- 5) Pull the fan from the motor shaft.
- 6) Remove two screws which secure the motor shaded pole.
- 7) Remove the motor shaded pole.
- 8) Reverse the above steps for reassembly.

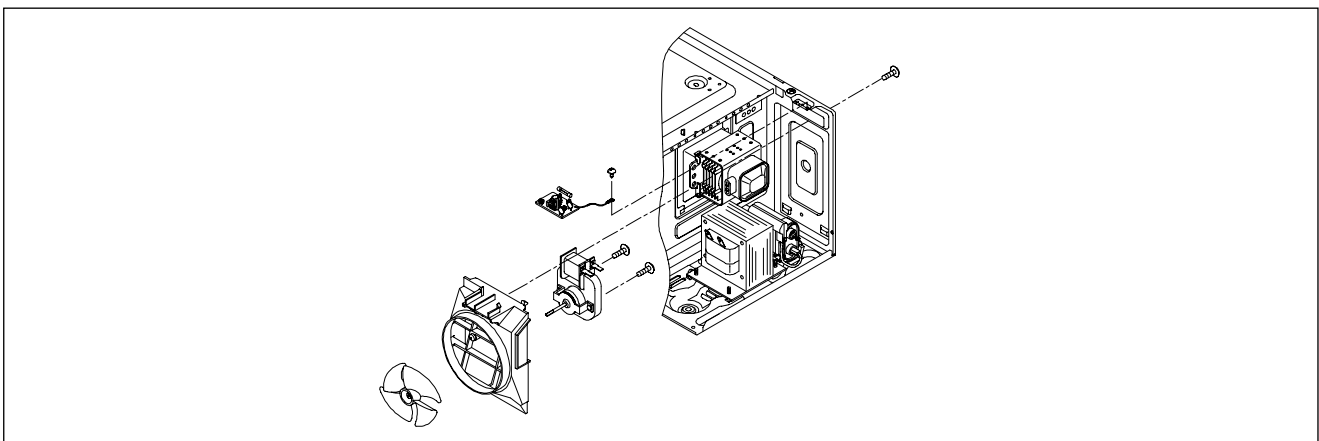

9. To remove H.V.transformer.

- 1) Remove four screws holding the H.V.transformer.
- 2) Remove the H.V.transformer.
- 3) Reverse the above steps for reassembly.

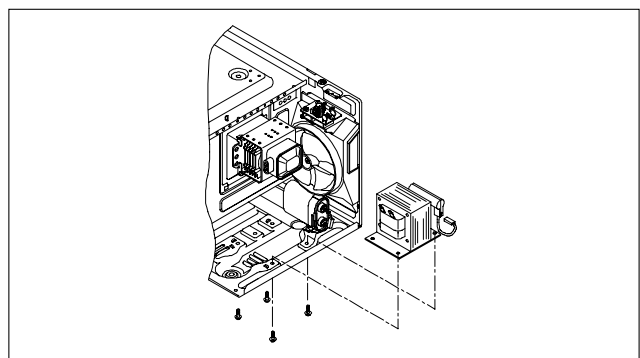

INTERLOCK MECHANISM AND ADJUSTMENT

The door lock mechanism is a device which has been specially designed to completely eliminate microwave radiation when the door is opened during operation, and thus to perfectly prevent the danger resulting from the leakage of microwave.

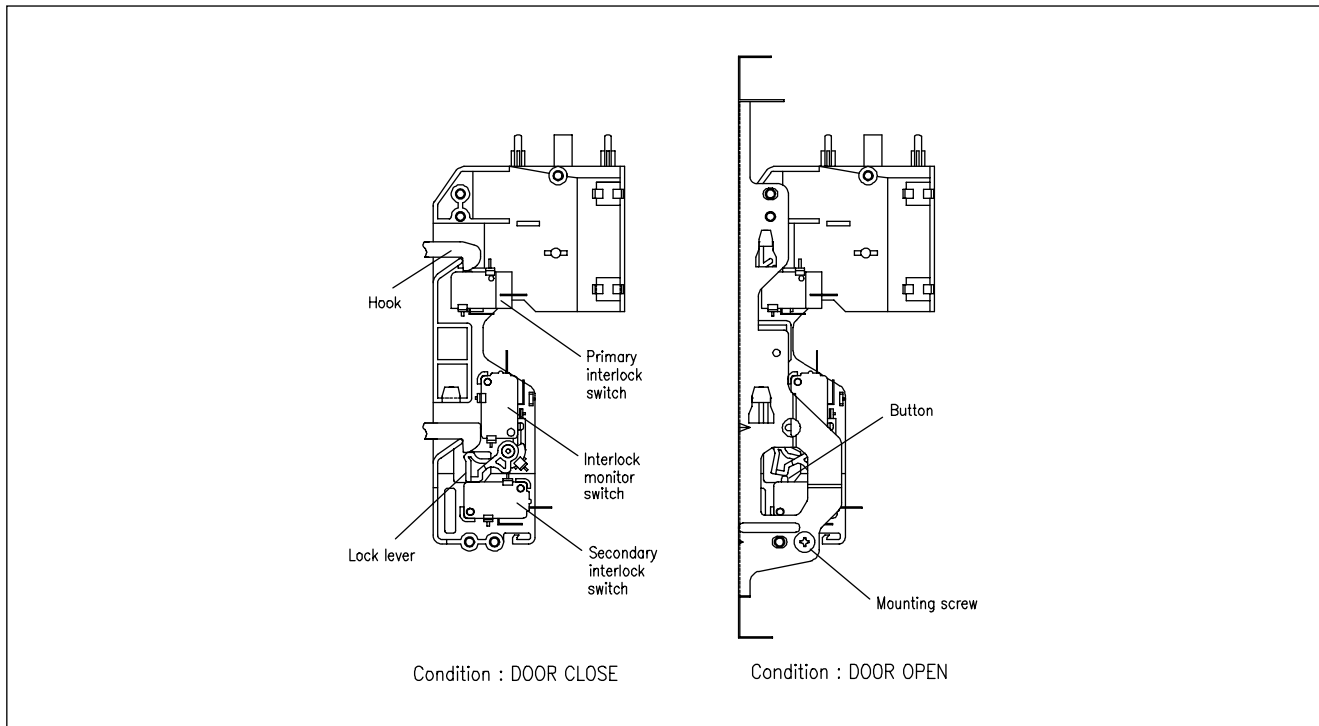

(1) Primary interlock switch

When the door is closed, the hook locks the oven door. If the door is not closed properly, the oven will not operate.

When the door is closed, the hook pushes the button of the microswitch. Then the button of the primary interlock switch bring it under "ON" condition.

(2) Secondary interlock switch and interlock monitor switch

When the door is closed, the hook pushes the lock lever downward. The lock lever presses the button of the interlock monitor switch to bring it under "NO" condition and presses the button of the secondary interlock switch to bring it under "ON" condition.

ADJUSTMENT :

Interlock monitor switch

When the door is closed, the interlock monitor switch should be changed(NO condition) before other switches are closed.

When the door is opened, the interlock monitor switch should be changed(NC condition) after other switches are opened.

(3) Adjustment steps

- Loosen the two mounting screws.
- Adjust interlock switch assembly position.
- Make sure that lock lever moves smoothly after adjustment is completed.
- Tighten completely two mounting screws.

NOTE :

Microwave emission test should be performed after adjusting interlock mechanism. If the microwave smission exceed $4\text{mW}/\text{cm}^2$, readjust interlock mechanism.

TROUBLE SHOOTING GUIDE

Following the procedure below to check if the oven is defective or not.

1. Check grounding before trouble checking.
2. Be careful of the high voltage circuit.
3. Discharge the high voltage capacitor.
4. When checking the continuity of the switches, fuse or high voltage transformer, disconnect one lead wire from these parts and check continuity with the AC plug removed. To do otherwise may result in a false reading or damage to your meter.

NOTE : When electric parts are checked, be sure the power cord is not inserted the wall outlet.
Check wire harness, wiring and connected of the terminals and power cord before check the parts listed below.

(TROUBLE 1) Oven does not operate at all ; any inputs can not be accepted.

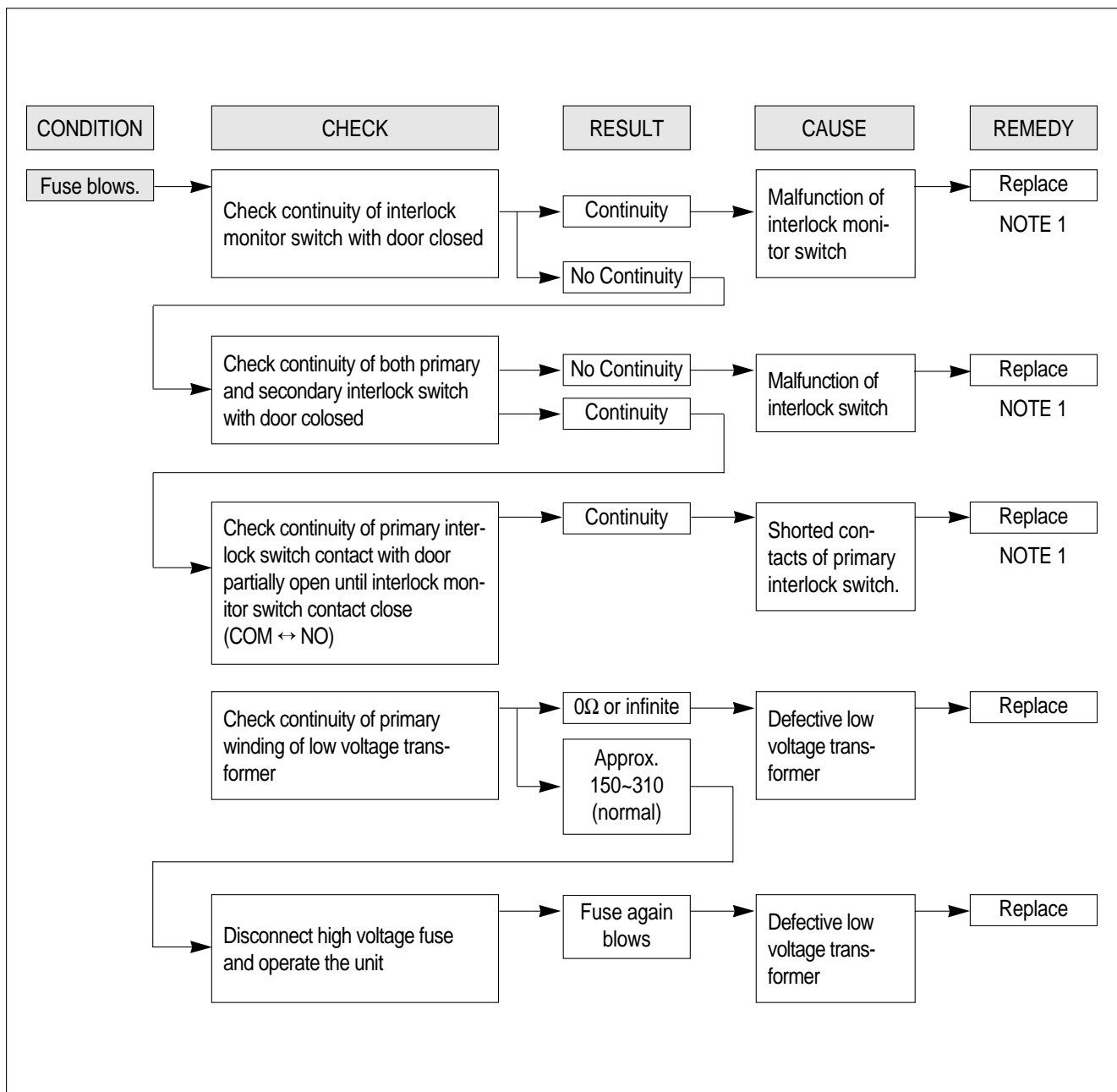

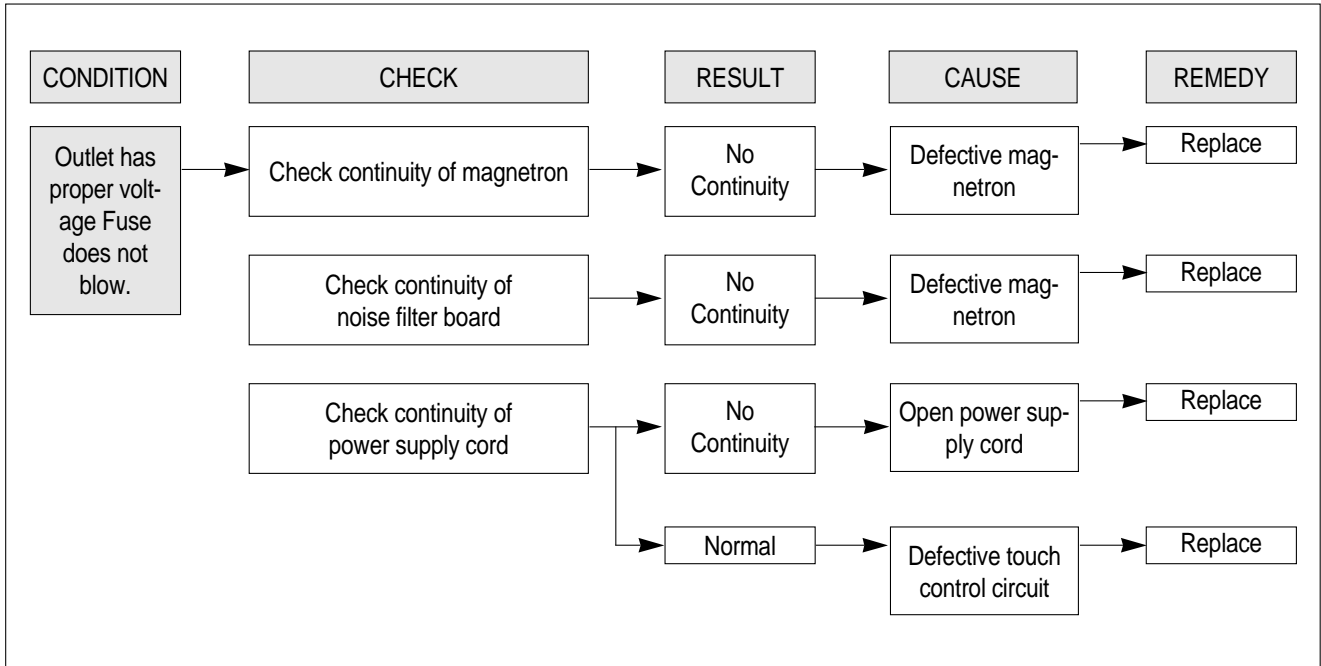

NOTE
 All these switches must be replaced at the same time, please refer to "Interlock Mechanism And Adjustment".

(TROUBLE 2) Display shows all figures selected, but oven does not start cooking, even though desired program and time are set and start button is tapped.

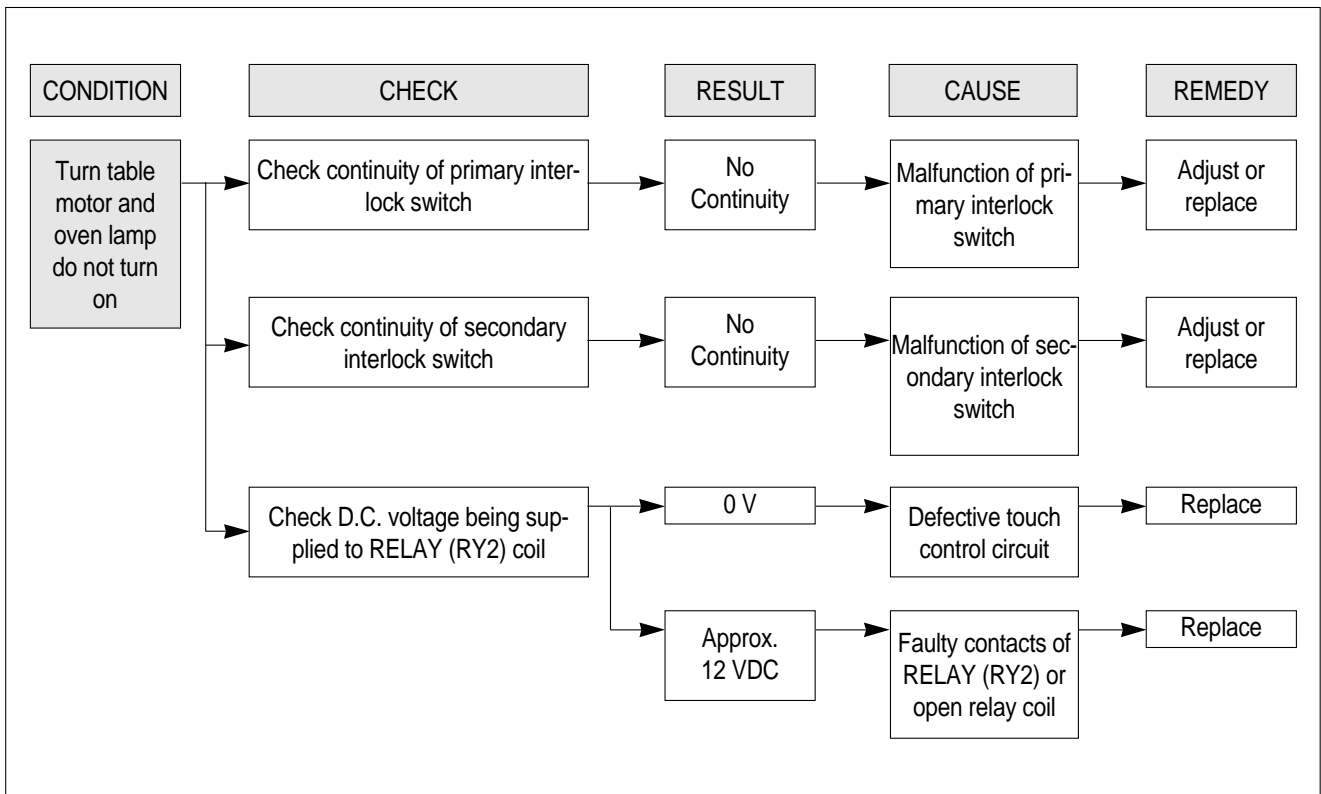

(TROUBLE 3) No microwave oscillation even though fan motor rotates.

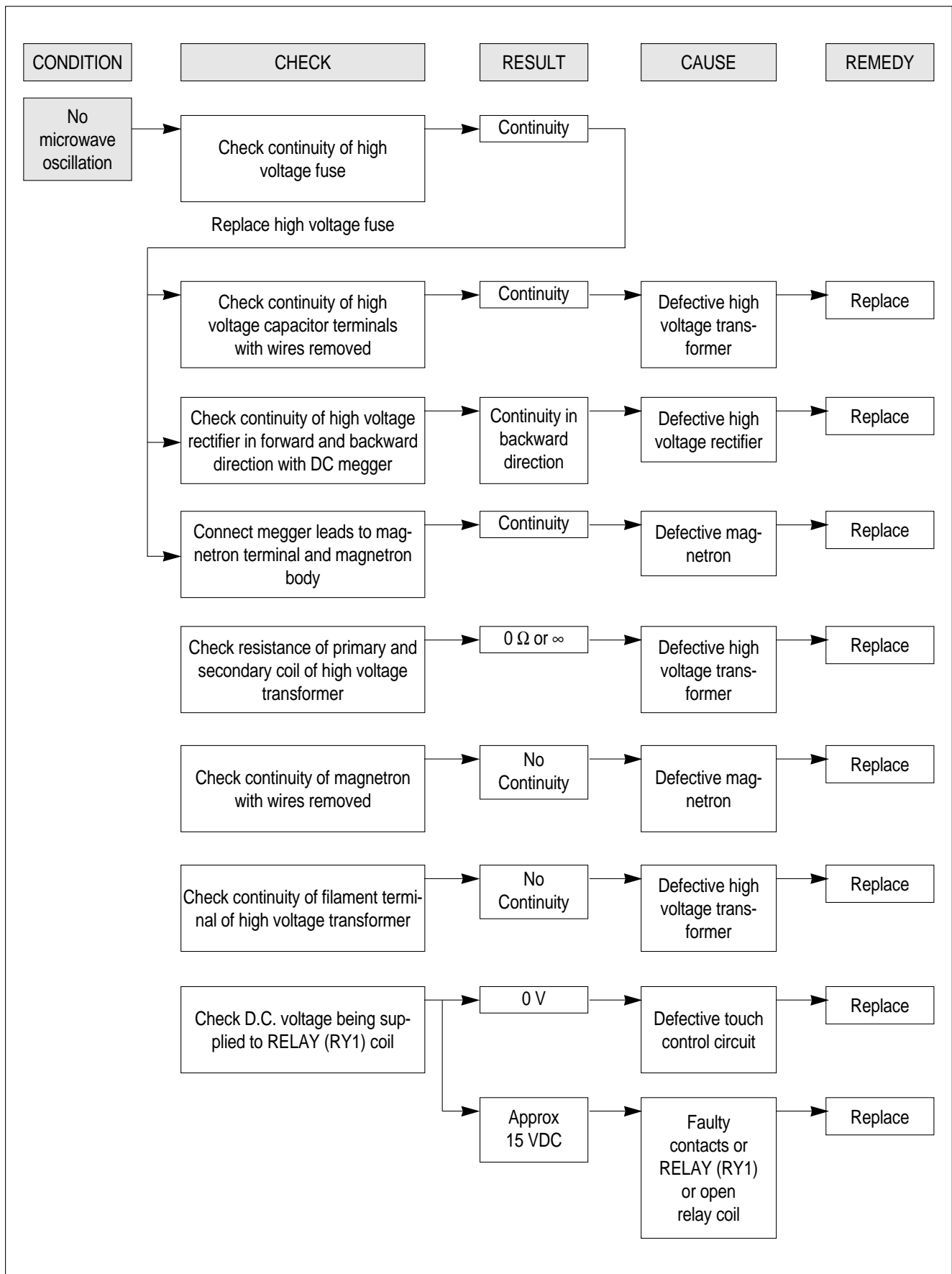

(TROUBLE 4) The following visual conditions indicate a probable defective touch control circuit or membrane switch assembly.

1. Incomplete segments
 - (1) Segments missing
 - (2) Partical segments missing
 - (3) Digit flickering other than normal display slight flickering
 - (4) “ :0” does not display when power is on.
2. A distinct changes in the display are not on when they should be.
3. One or more digits in the display are not on when they should be.
4. Display indicates a number different from one touched.
5. Specific numbers (for example 2 or 3) will not display when the button is touched.
6. Display does not count down or up with time cooking or clock operation.
7. Oven is programable and cooks normally but no display shows.
8. Display obviously jumps in time while counting down.
9. Display counts down noticeably too fast while cooking.
10. Display does not show the time of day when cancel button is touched.
11. Oven lamp and turntable motor do not stop although cooking is finished. Check if the RELAY 2 contacts close if they are close, replace touch control circuit.

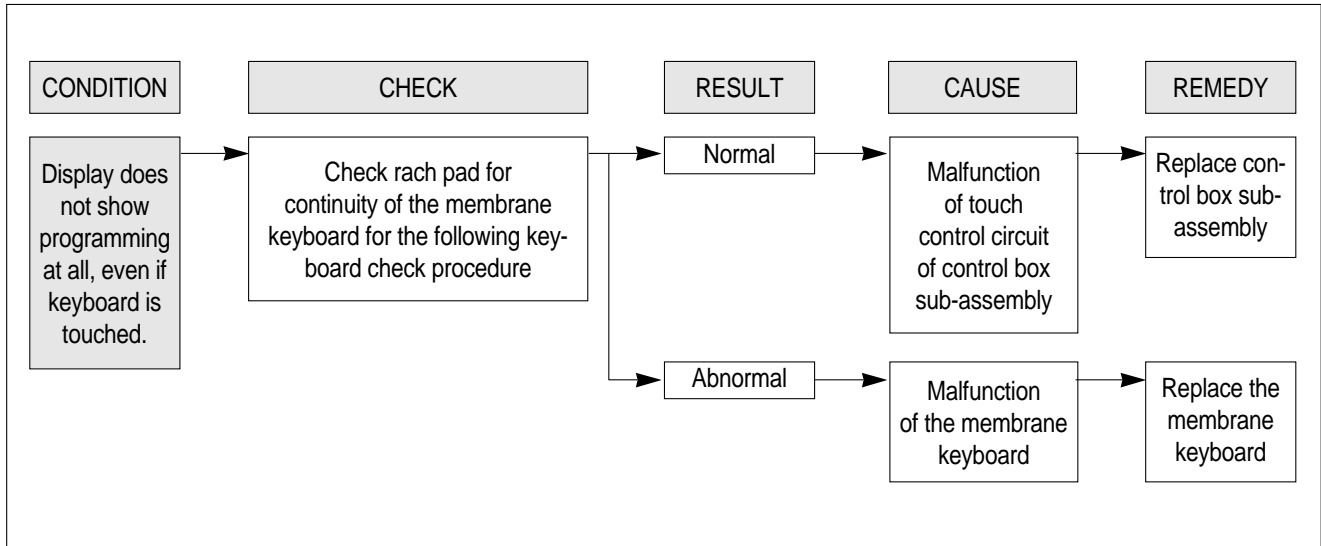
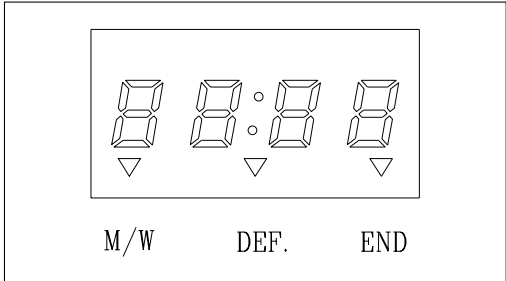

NOTE
 Before following the particular steps listed above in the trouble shooting guide for the membrane keyboard's failure, please check for the continuity of each wire-harness between the membrane keyboard and P.C.B. assembly.

MEASUREMENT AND TEST

1. MEASUREMENT OF THE MICROWAVE POWER OUTPUT

Microwave output power can be checked by indirectly measuring the temperature rise of a certain amount of water exposed to the microwave as directed below.

PROCEDURE

- Microwave power output measurement is made with the microwave oven supplied at rated voltage and operated at its maximum microwave power setting with a load of 1000 ± 5 cc of potable water.
- The water is contained in a cylindrical borosilicate glass vessel having a maximum material thickness of 3 mm and an outside diameter of approximately 190 mm.
- The oven and the empty vessel are at ambient temperature prior to the start of the test.

The initial temperature of the water is $10 \pm 2^\circ\text{C}$ ($50 \pm 3.6^\circ\text{F}$)

It is measured immediately before the water is added to the vessel.

After addition of the water to the vessel, the load is immediately placed on the center of the shelf, which is in the lowest normal position.

- Microwave power is switched on.
- Heating time should be exactly **A** seconds. (Refer to table as following)
Heating time is measured while the microwave generator is operating at full power.
The filament heat-up time for magnetron is not included.
- The initial and final temperature of water is selected so that the maximum difference between the ambient and final water temperature is 5K.
- The microwave power output P in watts is calculated from the following formula :

$$P = 4187 \times \frac{\Delta T}{t}$$

- ΔT is difference between initial and ending temperature.
- t is the heating time.

The power measured should be B (Refer to SPECIFICATIONS) $W \pm 10.0\%$.

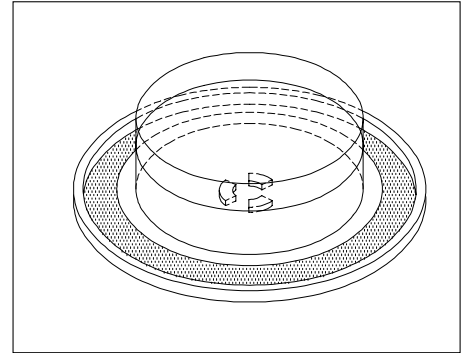

CAUTION :

- Water load should be measured exactly to 1 liters.
- Input power voltage should be exactly specified voltage (Refer to SPECIFICATIONS).
- Ambient temperature should be $20 \pm 2^\circ\text{C}$ ($68 \pm 3.6^\circ\text{F}$)

Heating time for power output:

A(second)	70	64	60	56	52	49	47	44	42	40	38
B(W)	600	650	700	750	800	850	900	950	1000	1050	1100

2. MICROWAVE RADIATION TEST

CAUTION :

1. Make sure to check the microwave leakage before and after repair of adjustment.
2. Always start measuring of an unknown field to assure safety for operating personnel from microwave energy.
3. Do not place your hands into any suspected microwave radiation field unless the safe density level is known.
4. Care should be taken not to place the eyes in direct line with the source of microwave energy.
5. Slowly approach the unit under test until the radiometer reads an appreciable microwave leakage from the unit under the test.

PROCEDURES

1. Prepare Microwave Energy Survey Meter, 600cc glass beaker, and glass thermometer 100°C(212°F).
2. Pour 275cc±15cc of tap water initially at 20±5°C(68±9°F) in the 600cc glass beaker with an inside diameter of approx. 95mm(3.5in.).
3. Place it at the center of the tray and set it in a cavity.
4. Close the door and operate the oven.
5. Measure the leakage by using Microwave Energy Survey Meter with dual ranges, set to 2450MHz.
 - 1) Measured radiation leakage must not exceed the value prescribed below. Leakage for a fully assembled oven with door normally closed must be less than 4mW/cm².
 - 2) When measuring the leakage, always use the 5cm(2in.) space cone with probe. Hold the probe perpendicular to the cabinet and door. Place the space cone of the probe on the door, cabinet, door seem, door viewing screen, the exhaust air vents and the suction air vents.
 - 3) Measuring should be in a counter-clockwise direction at a rate of 1 in./sec. If the leakage of the cabinet door seem is unknown, move the probe more slowly.
 - 4) When measuring near a corner of the door, keep the probe perpendicular to the areas making sure the probe end at the base of the cone does not get closer than 2 in. from any metal. If it does not, erroneous reading may result.

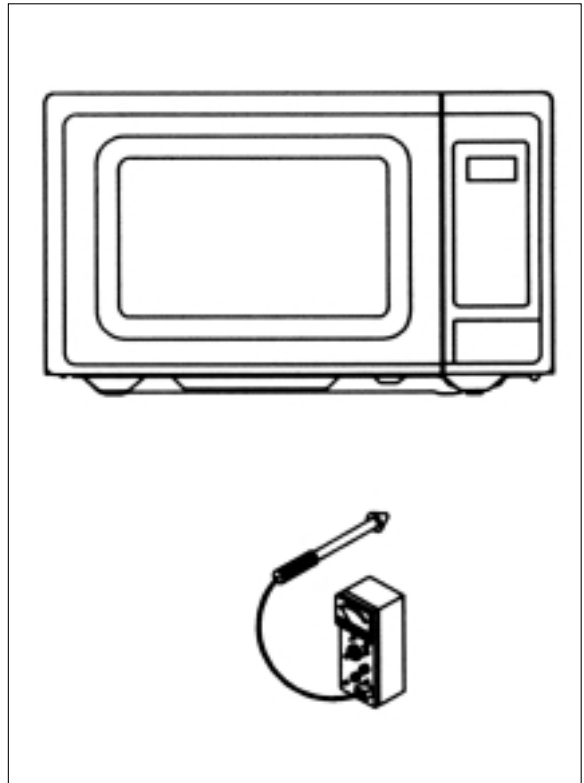

3. COMPONENT TEST PROCEDURE

- High voltage is present at the high voltage terminal of the high voltage transformer during any cooking cycle.
- It is neither necessary nor advisable to attempt measurement of the high voltage.
- Before touching any oven components or wiring, always unplug the oven from its power source and discharge the capacitor.

1. High voltage transformer

- (1) Remove connections from the transformer terminals and check continuity.
- (2) Normal readings should be as follows:
 - Secondary windingApprox. $140\Omega \pm 10\%$
 - Filament windingApprox. 0Ω
 - Primary windingApprox. 2Ω

2. High voltage capacitor

- (1) Check continuity of capacitor with meter on the highest OHM scale.
- (2) A normal capacitor will show continuity for a short time, and then indicate $10M\Omega$ once the capacitor is charged.
- (3) A shorted capacitor will show continuous continuity.
- (4) An open capacitor will show constant $10M\Omega$.
- (5) Resistance between each terminal and chassis should be infinite.

3. High voltage diode

- (1) Isolate the diode from the circuit by disconnecting the leads.
- (2) With the ohmmeter set on the highest resistance scale measure the resistance across the diode terminals.
 - Reverse the meter leads and again observe the resistance reading.
 - Meter with 6V, 9V or higher voltage batteries should be used to check the front-back resistance of the diode, otherwise an infinite resistance may be read in both directions.
 - A normal diode's resistance will be infinite in one direction and several hundred $K\Omega$ in the other direction.

4. Magnetron

For complete magnetron diagnosis, refer to "Measurement of the Microwave Power Output".
Continuity checks can only indicate an open filament or a shorted magnetron.
To diagnose for an open filament or a shorted magnetron.

- (1) Isolate magnetron from the circuit by disconnecting the leads.
- (2) A continuity check across magnetron filament terminals should indicate 0.1Ω or less.
- (3) A continuity check between each filament terminal and magnetron case should read open.

5. Fuse

If the fuse in the primary and monitor switch circuit is blown when the door is opened, check the primary and monitor switch before replacing the blown fuse.

In case the fuse is blown by an improper switch operation, replace the defective switch and fuse at the same time.
Replace just the fuse if the switches operate normally.

WIRING DIAGRAM

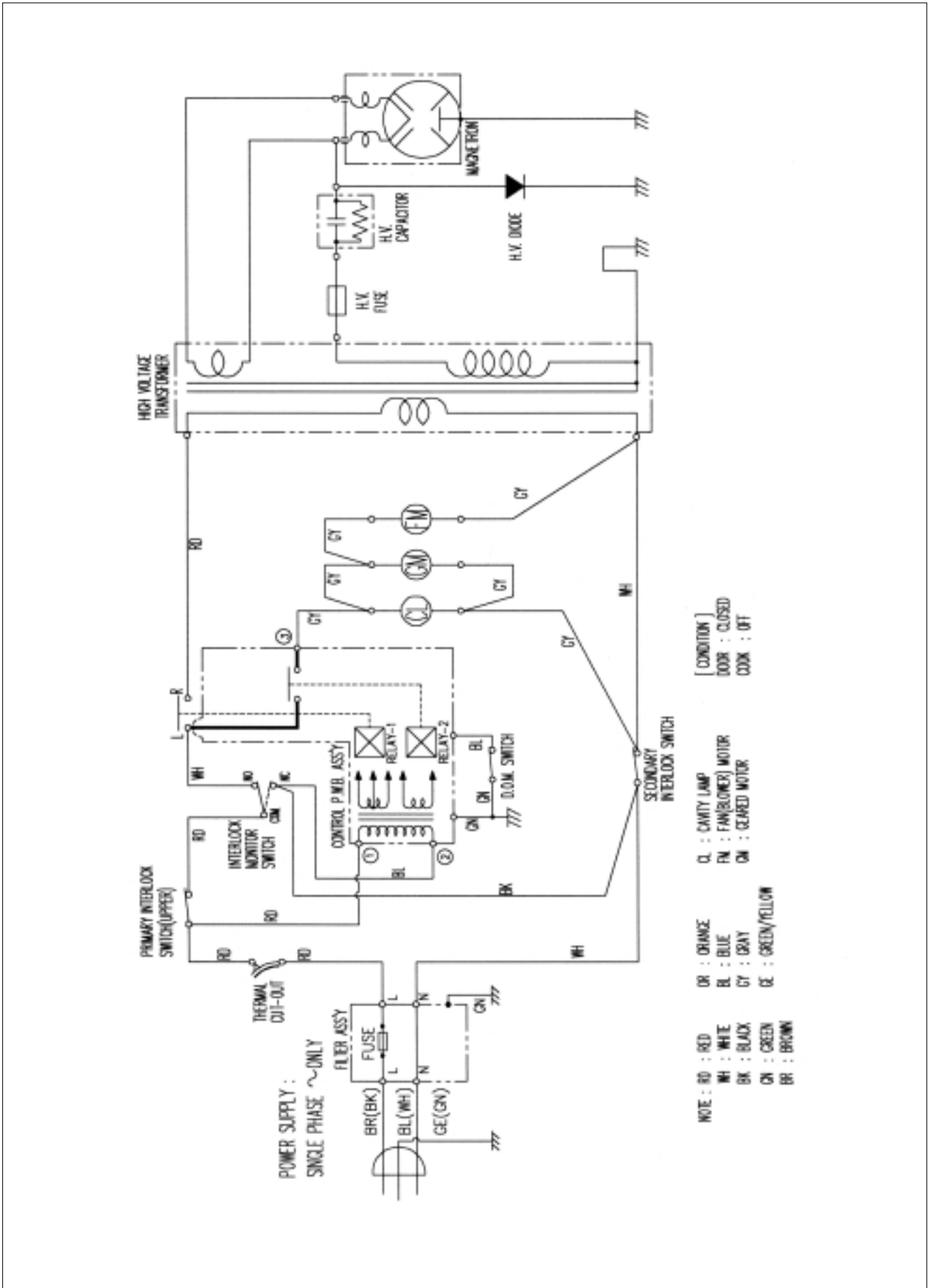

PRINTED CIRCUIT BOARD

1. CIRCUIT CHECK PROCEDURE

1. Low Voltage Transformer check

- The low voltage transformer is located on the P.C.B.
- Measuring condition: input voltage : 230V/Frequency : 50Hz

Terminal Voltage	LOAD	NO LOAD
4-8	AC 25.8 V	AC 31.8 V

NOTE :

1. Refer to Circuit Diagram (point 4).
2. Secondary side voltage of the low voltage transformer changes in proportion to fluctuation of power source voltage.
3. The allowable tolerance of the secondary voltage is within $\pm 5\%$ of nominal voltage.

2. Voltage check

- Key check point

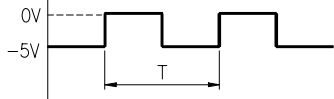
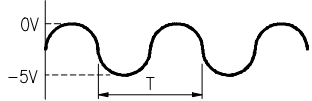
NO	CHECK POINT	REMARK
1	IC 1 PIN 14	-5 VDC
2	IC 1 PIN 22	 T:20ms(50Hz)
3	IC 1 PIN 1 OR 2	 T:250ns(4MHz)

- Check method

NO	MEASURE POINT	WAVE FORM	REMEDY	REMARK
1	MP1	DC -5V \pm 0.25V	Replace VL1, EC1	NO LOAD
2	MP2	DC -12V \pm 2.0V	Replace EC2, D9, 10, 11	NO LOAD

NOTE :

Each measure point must be measured with GND points.

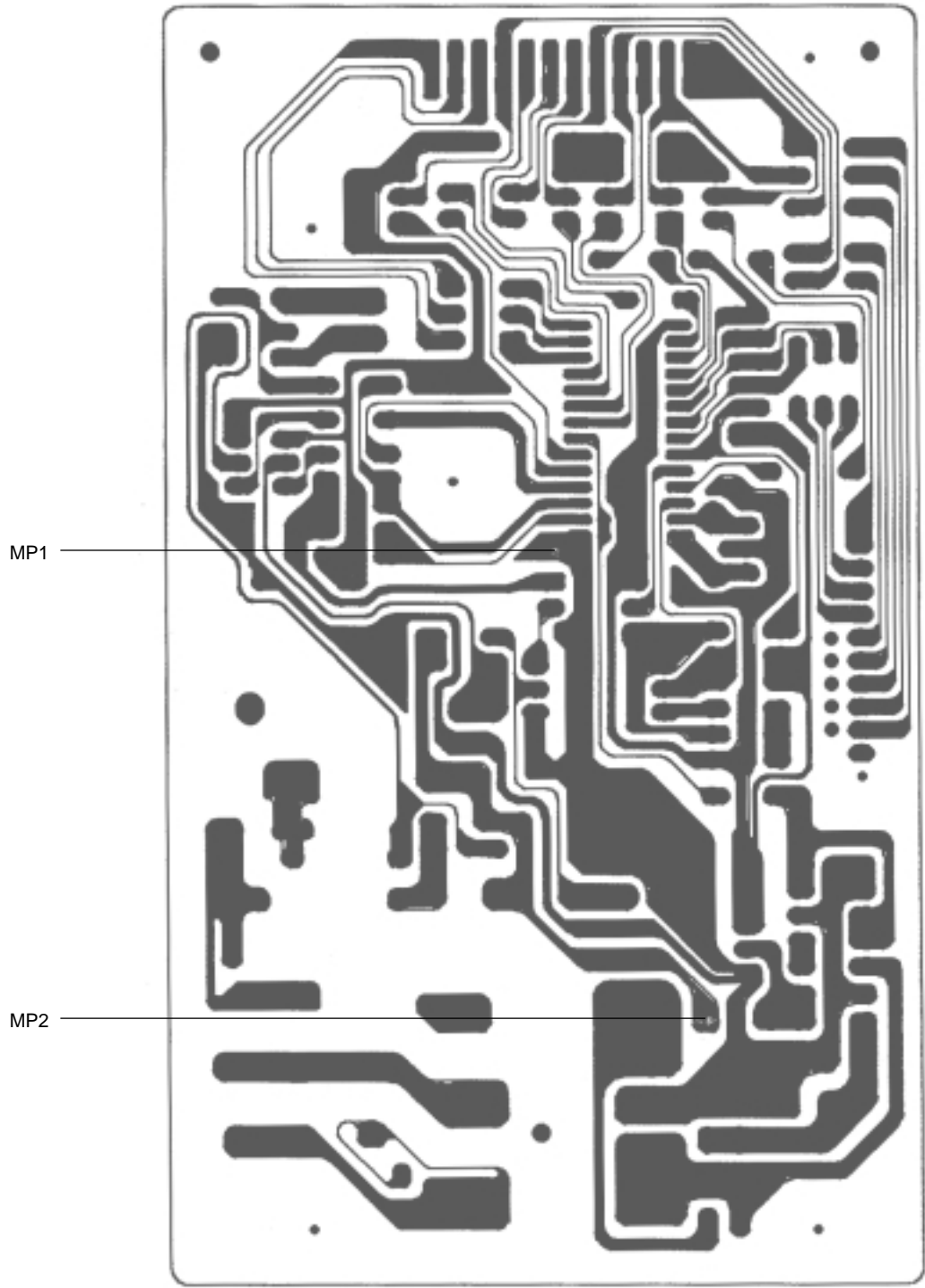

Measure Point

3. When there is no microwave oscillation

1) When touching **START** pad, oven lamp does not turn on.

Fan motor does not rotate, but cook indicator in display comes on.

* Cause : **RELAY 2** does not operate. → refer to Circuit Diagram (Point 3)

- Check method

STATE	POINT	A	B
	RELAY 2 ON	-5VDC	GND
	RELAY 2 OFF	GND	-12VDC

2) When touching **START** pad, oven lamp turns on.

Fan motor and turntable rotate and cook indicator in display comes on.

* Cause : **RELAY 1** does not operate. → refer to Circuit Diagram (Point 2)

- Check method

STATE	POINT	A	B
	RELAY 1 ON	-5VDC	GND
	RELAY 1 OFF	GND	-12VDC

4. When the door is opened during operation, the count down timer does not stop.

→ refer to Circuit Diagram (Point 1)

-Check method

STATE	POINT	A	B
	1) DOOR OPEN	OPEN	-5VDC
	2) DOOR CLOSED	CLOSE	GND

CHECK NO	METHOD	REMEDY
1	Check the stage (ON, OFF) of the door open monitor switch by resistance measurement.	Replace door open monitor switch.

5. When the digital clock does not operate properly.

→ refer to Circuit Diagram (Point 5)

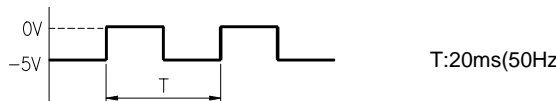
POINT	WAVE FORM
A	

* If clock does not keep exact time, you must check resistor R23, 24 zener diode ZD2.

2. PCB CIRCUIT DIAGRAM

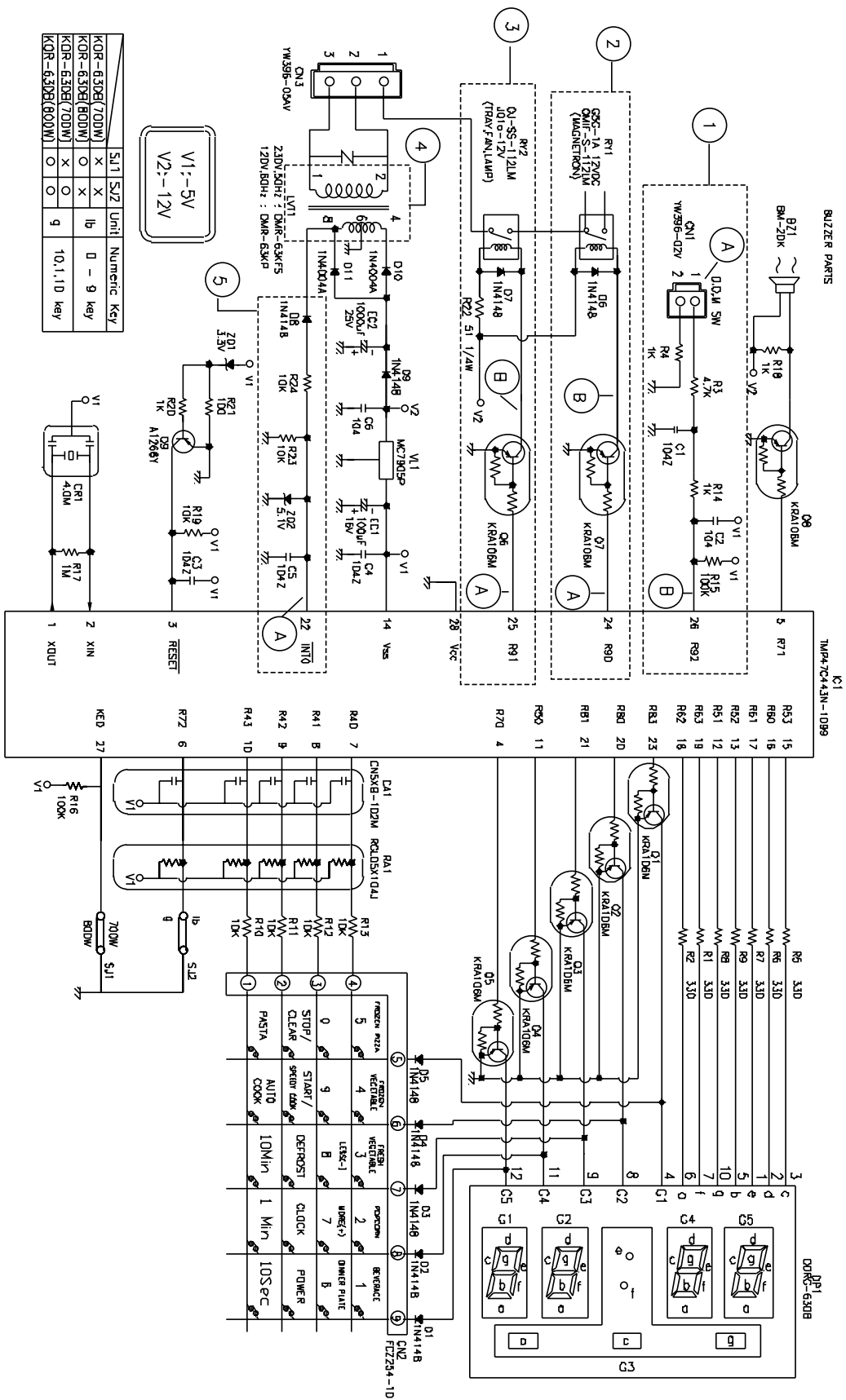

✓ **Caution:** In this Service Manual, some parts can be changed for improving, their performance without notice in the parts list. So, if you need the latest parts information, please refer to PPL(Parts Price List) in Service information Center(<http://svc.dwe.co.kr>)

3. P.C.B. LOCATION NO.

1) KOR-63DB9S/KOR-63FB9S

NO.	NAME	SYMBOL	SPECIFICATION	PART CODE	Q'TY
1	CAPACTIOR ELEC	EC1	16V RS 100MF	CEXF1C101V	1
2	CAPACTIOR ELEC	EC2	25V RSS 1000MF	CEXF1E102V	1
3	CONNECTOR WAFER	CN1	YW396-02V	351915020	1
4	CONNECTOR FILM	CN2	FCZ 254-10P	441M367150	1
5	CONNECTOR WAFER	CN3	YW396-05AV	3519150510	1
6	DIODE RECTIFY	D1~9	1N4148	DZN4148---	9
7	DIODE RECTIFY	D10, D11	KN4004A	DZN4004A--	2
8	DIODE ZENER	ZD1	UZ- 3.3BSB 1/2W	DZUZ3R3BSB	1
9	DIODE ZENER	ZD2	UZ- 5.1BSB 1/2W	DZUZ5R1BSB	1
10	LED DISPLAY	DP1	DDRG-63DB	DDDRG63DB-	1
11	PCB MAIN	M171	81.5X139.9	3514324000	1
12	C ARRAY	CA1	5102M	CN5XB-102M	1
13	R ARRAY	RA1	6P(5) 1/8 100K J	RA-86X104J	1
14	REGISTER	R1, R2, R5~R9	1/6W 330 5%	RD-AZ331J-	7
15	REGISTER	R4, R14, R20	1/6W 1K 5%	RD-AZ102J-	3
16	REGISTER	R3	1/6W 4.7K 5%	RD-AZ472J-	1
17	REGISTER	R15, R16	1/6W 100K 5%	RD-AZ104J-	2
18	REGISTER	R21	1/6W 100 5%	RD-AZ101J-	1
19	REGISTER	R10~13, R19, R23~24	1/6W 10K 5%	RD-AZ103J-	7
20	REGISTER	R17	1/6 1M 5%	RD-AZ105J-	1
21	REGISTER	R22	1/4W 51 5%	RD-4Z510J-	1
22	RESONATOR CERAMIC	CR1	4.00MTS	5P4R00MTS-	1
23	IC REGULATOR	VL1	MC7905C	1MC7905C--	1
24	TRANSISTOR	Q1~7	KRA-106M	TZRA106M--	7
25	TRANSISTOR	Q9	KTA-1266Y	TZTA1226Y-	1
26	TRANS POWER	LVT	DMR-63KFS(35X11)	5EPV035306	1
27	WIRE COPPER	J2~J4, J8~J10, SJ2	1/0.52 TIN COATING(7.5MM)	85801052GY	7
28	WIRE COPPER	J1, J5, J6, J11	1/0.52 TIN COATING(10MM)	85801052GY	4
29	IC MICOM	IC1	TMP47C443N-1D99	13GS63DB00	1
30	SW RELAY	RY1	G5G-1A-1C-12V	5SC0101121	1
31	SW RELAY	RY2	OJ-SS-112LM	5SC0101404	1
32	CAPACITOR CERA	C1~6	104 50V Z AXIAL	CCZF1H104Z	6

EXPLODED VIEW AND PARTS LIST

1. DOOR ASSEMBLY

Refer to Disassembly and assembly.

2. CONTROL PANEL ASSEMBLY

Refer to Disassembly and assembly.

3. TOTAL ASSEMBLY

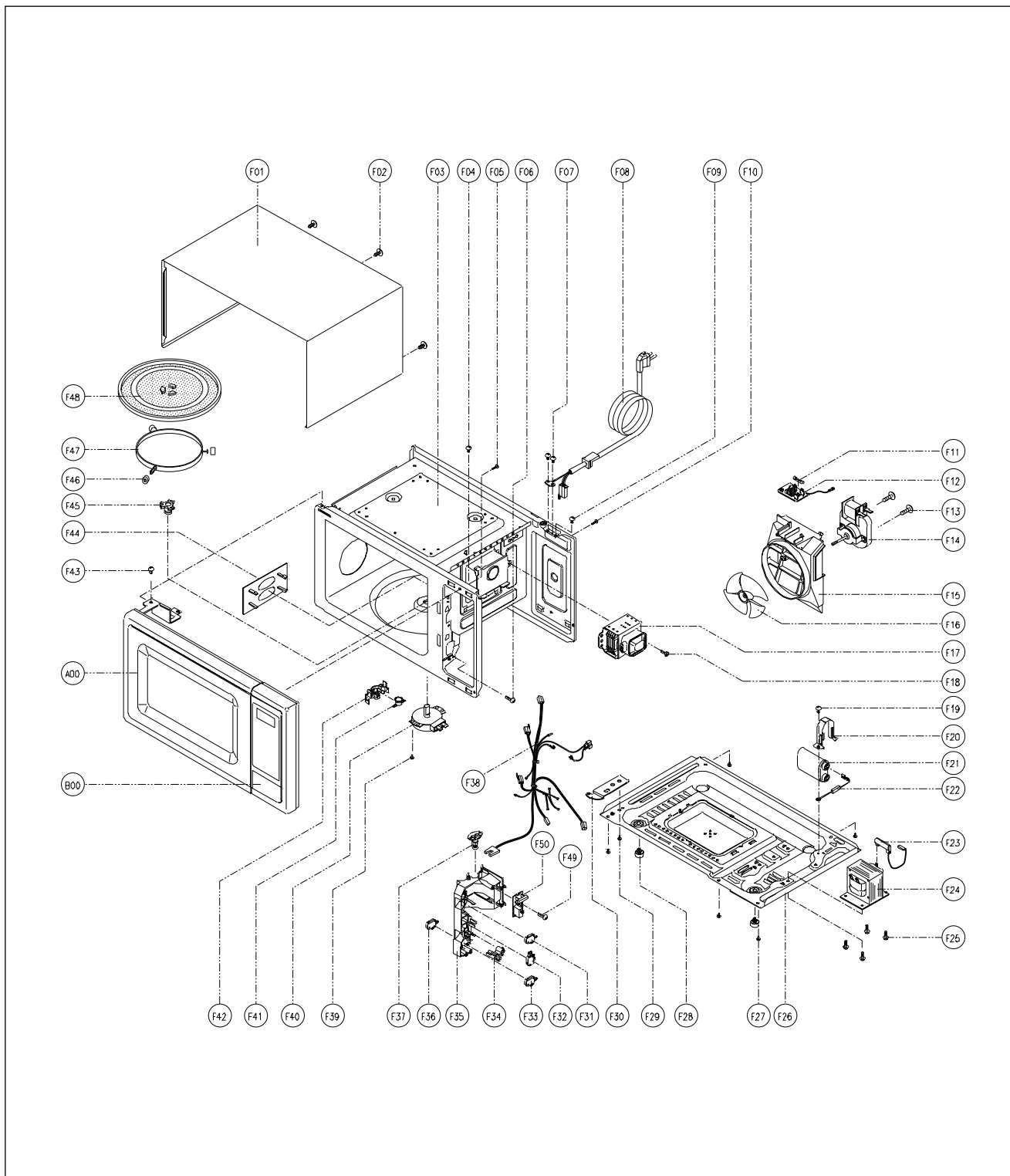

✓ **Caution:** In this Service Manual, some parts can be changed for improving, their performance without notice in the parts list. So, if you need the latest parts information, please refer to PPL(Parts Price List) in Service information Center(<http://svc.dwe.co.kr>)

NO	PART CODE	PART NAME	DESCRIPTION	Q'TY
A00	3511714420	DOOR AS	KOR-63D59A	1
	3511714450	DOOR AS	KOR-63F59A	1
B00	3516720620	CONTROL-PANEL AS	KOR-63DB9S	1
	3516720640	CONTROL-PANEL AS	KOR-63FB9S	1
F01	3510805000	CABINET	SECC T0.5	1
F02	7112401011	SCREW TAPPING	T1 TRS 4*10 MFZN	3
F03	3516109000	CAVITY WELD AS	CAVITY WELD AS	1
	3516109600	CAVITY JOINT AS	KOR-63150S	1
F04	7112401011	SCREW TAPPING	T1 TRS 4*10 MFZN	1
F05	7122401211	SCREW TAPPING	T2S TRS 4*12 MFZN	1
F06	7122401211	SCREW TAPPING	T2S TRS 4*12 MFZN	1
F07	7112401011	SCREW TAPPING	T1 TRS 4*10 MFZN	2
F08	35113AEQ0D	CORD POWER AS	3X0.75 70X70 100-RTML	1
F09	7112401011	SCREW TAPPING	T1 TRS 4*10 MFZN	1
F10	7122401211	SCREW TAPPING	T2S TRS 4*12 MFZN	1
F11	4415D67620	FUSE	250V 12A 65TS	1
	4415D67120	FUSE	250V 12A MDA	1
F12	3518606200	NOISE-FILTER	DWLF-M12	1
F13	7121403011	SCREW TAPPING	T2S PAN 4X30 MFZN	2
F14	3963512310	MOTOR SHADED POLE	230V 20W MW10CA-M02	1
F15	3512517000	GUIDE WIND	PP	1
F16	3511800300	FAN	PP+30%GLASS	1
F17	3518002400	MAGNETRON	2M218J(F)	1
F18	3516004000	SPECIAL SCREW	T2 BOLT FLANGE 5X12 DACRO	1
F19	7S422X4081	SCREW SPECIAL	TT2 TRS 4X8 SE MFZN	1
F20	3513003200	HOLDER HV CAPACITOR	SECC T0.6	1
F21	3518302200	CAPACITOR HV	2100VAC 0.98 μ F #187	1
F22	3518400900	DIODE HV AS	HVR-1X-30B #187	1
	3518401000	DIODE HV AS	ESJC13-12BX #187	1

✓ **Caution:** In this Service Manual, some parts can be changed for improving, their performance without notice in the parts list. So, if you need the latest parts information, please refer to PPL(Parts Price List) in Service information Center(<http://svc.dwe.co.kr>)

NO	PART CODE	PART NAME	DESCRIPTION	Q'TY
F23	3518701100	FUSE HV	5KV 0.55A HV-41A55-02	1
F24	3518113751	TRANS HV	TM-N70S0-63T (KOR-63DB9S/63FB9S)	1
	3518113701	TRANS HV	DY-N80S0-63T (KOR-63DB0S/63FB0S)	1
F25	3516003700	SPECIAL SCREW	TT3 HEX 4X8 FLG MFZN	4
F26	3510311710	BASE	SECC T0.6	1
F27	7112401011	SCREW TAPPING	T1 TRS 4*10 MFZN	5
F28	3512100900	FOOT	PP DASF-130	2
F29	7S422X4081	SCREW SPECIAL	TT2 TRS 4X8 SE MFZN	1
F30	3515201101	STOPPER HINGE *U	SCP-1 T2.5	1
F31	4415A17352	SW MICRO	VP-533A-OF SPNO #187 200G	1
F32	4415A66910	SW MICRO	VP-531A-OF/SZM-V16-FA-61	1
F33	4415A17352	SW MICRO	VP-533A-OF SPNO #187 200G	1
F34	3513702600	LEVER LOCK	POM	1
F35	3513811730	LOCK	POM NATURAL (KOR-63DB)	1
	3513811700	LOCK	POM BLACK (KOR-63FB)	1
F36	3518571000	SWITCH PUSH	MP101C	1
F37	3513601600	LAMP	BL 240V 25W T25 C7A H187	1
F38	3512715000	HARNESS MAIN	KOR-631G0S	1
F39	7121400611	SCREW TAPPING	T2S PAN 4X6 MFZN	1
F40	3966310100	MOTOR SYNCRO	220V 2.5W GM-16-24FD12	1
F41	3518905300	THERMOSTAT	OFF:75 ON:65 H #187 NB	1
F42	3513003400	HOLDER THERMOSTAT	PBT	1
F43	3516003700	SPECIAL SCREW	TT3 HEX 4X8 FLG MFZN	1
F44	3511406220	COVER WAVE GUIDE	PP J640A	1
F45	3517400620	COUPLER	XAREC	1
F46	3514700710	ROLLER	TEFLON	3
F47	3512517300	GUIDE ROLLER	PP 5113MF6 A353B	1
F48	3517203600	TRAY	GLASS	1
F49	7122401211	SCREW TAPPING	T2S TRS 4*12 MFZN	1
F50	3518570400	SWITCH S/A RELAY	DWSR-1	1

DAEWOO
DAEWOO ELECTRONICS CO., LTD.
686, AHYEON-DONG MAPO-GU SEOUL, KOREA
C.P.O. BOX 8003 SEOUL, KOREA
TELEX: DWELEC K28177-8
CABLE: "DAEWOOELEC"

S/M NO. : R63DB9S002

PRINTED DATE: Jul. 2001

Free Manuals Download Website

<http://myh66.com>

<http://usermanuals.us>

<http://www.somanuals.com>

<http://www.4manuals.cc>

<http://www.manual-lib.com>

<http://www.404manual.com>

<http://www.luxmanual.com>

<http://aubethermostatmanual.com>

Golf course search by state

<http://golfingnear.com>

Email search by domain

<http://emailbydomain.com>

Auto manuals search

<http://auto.somanuals.com>

TV manuals search

<http://tv.somanuals.com>