DS2400

Installation Manual

DATALOGIC DL
Bar Code & More
.....

DS2400
INSTALLATION MANUAL

We

Datalogic S.p.A.
Via Candini, 2
40012 - Lippo di Calderara
Bologna - Italy

declare under our sole responsibility that the product

DS2400-XXXX, Laser Scanner and all its models

to which this declaration relates is in conformity with the following standards or other normative documents

EN 55022, August 1994: LIMITS AND METHODS OF MEASUREMENTS OF RADIO DISTURBANCE CHARACTERISTICS OF INFORMATION TECHNOLOGY EQUIPMENT (ITE)

EN 50082-2, March 1995: ELECTROMAGNETIC COMPATIBILITY. GENERIC IMMUNITY STANDARD. PART 2: INDUSTRIAL ENVIRONMENT

Following the provision of the Directive(s):

89/336 CEE AND SUCCESSIVE AMENDMENTS, 92/31 CEE; 93/68 CEE

Lippo di Calderara, 09.11.1999

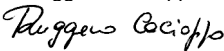
Ruggero Cacioppo

Quality Assurance Supervisor

Product names mentioned herein are for identification purposes only and may be trademarks and or registered trademarks of their respective companies.

Datalogic reserves the right to make modifications and improvements without prior notification.

© 1999 Datalogic S.p.A.

821000420

CONTENTS

GUIDE TO INSTALLATION	v
General View	vi
SAFETY PRECAUTIONS	vii
Laser Safety.....	vii
Standard Regulations	vii
Power Supply.....	viii
1 GENERAL FEATURES	1.1
1.1 Introduction	1.1
1.2 Description.....	1.1
1.3 Available Models.....	1.3
1.4 GFC-2100 Accessory Installation	1.4
2 INSTALLATION	2.1
2.1 Package Contents	2.1
2.2 Mechanical Installation	2.2
2.3 Junction Box Installation.....	2.3
2.3.1 Junction Box Mounting	2.3
2.3.2 Junction Box Electrical Connections.....	2.5
2.4 Electrical Connections	2.8
2.4.1 Power Supply.....	2.9
2.4.2 Main Serial Interface.....	2.9
RS232 Interface.....	2.10
RS485 Full-duplex Interface	2.11
RS485 Half-duplex Interface	2.12
20 mA Current Loop Interface (INT-22 Accessory Only).....	2.13
2.4.3 Auxiliary RS232 Interface	2.14
2.4.4 Inputs	2.15
2.4.5 Outputs	2.17
2.5 Positioning	2.17
2.6 Typical Layouts	2.19
2.6.1 Point-to-Point	2.19
2.6.2 Pass Through	2.20
2.6.3 RS232 Master/Slave.....	2.21
2.6.4 RS485 Master/Slave.....	2.22
2.6.5 Multiplexer	2.23

3	READING FEATURES	3.1
3.1	Step-Ladder Mode	3.1
3.2	Picket-Fence Mode	3.2
3.3	Performance	3.3
3.3.1	Raster	3.3
3.4	Reading Diagrams	3.4
4	MAINTENANCE	4.1
4.1	Cleaning	4.1
5	TECHNICAL FEATURES	5.1

GUIDE TO INSTALLATION

The following can be used as a checklist to verify all of the steps necessary for complete installation of the DS2400 scanner.

- 1) Read all information in the section "Safety Precautions" at the beginning of this manual.
- 2) Correctly position and mount the scanner for barcode reading according to the information in par. 2.2, 2.5 and 3.4.
- 3) Provide correct system cabling according to the signals necessary for your application (see all sub-paragraphs under 2.3 and 2.4). See also sub-paragraphs under 2.6 for reference.
- 4) Install the Configuration Disk.
Upon successful completion of the installation, the readme.hlp file is opened, giving details about how to get started configuring your scanner. See also the [Guide To Rapid Configuration](#) link. Specific parameter details are available in the Help On Line.

NOTE

Fine tuning of the scanner position for barcode reading can be accomplished using the [Test Mode](#) as described in WinHost.

The installation is now complete.

DS2400

General View



Figure A

- | | | | |
|---|------------------------|---|---------------------------------|
| 1 | Power ON \ Data Tx LED | 5 | Warning and Device Class Labels |
| 2 | External Trigger LED | 6 | Laser Beam Output Window |
| 3 | Good Read LED | 7 | Accessory Mounting Holes |
| 4 | Laser ON LED | 8 | Mounting Holes |

SAFETY PRECAUTIONS

LASER SAFETY

The following information is provided to comply with the rules imposed by international authorities and refers to the correct use of the DS2400 scanner.

Standard Regulations

This scanner utilizes a low-power laser diode. Although staring directly at the laser beam momentarily causes no known biological damage, avoid staring at the beam as one would with any very strong light source, such as the sun. Avoid that the laser beam hits the eye of an observer, even through reflective surfaces such as mirrors, etc.

This product conforms to the applicable requirements of both IEC 825-1 and CDRH 21 CFR 1040 at the date of manufacture. The scanner is classified as a Class 2 laser product according to IEC 825-1 regulations and as a Class II laser product according to CDRH regulations.

There is a safety device which allows the laser to be switched on only if the motor is rotating above the threshold for its correct scanning speed.

The laser beam can be switched off through a software command (see also «*Beam Shutter*» in the WinHost Help On Line).

WARNING

Use of controls or adjustments or performance of procedures other than those specified herein may result in exposure to hazardous visible laser light.

The laser light is visible to the human eye and is emitted from the window on the front of the scanner (Figure A, .

Warning labels indicating exposure to laser light and the device classification are applied onto the body of the scanner (Figure A, (5)).

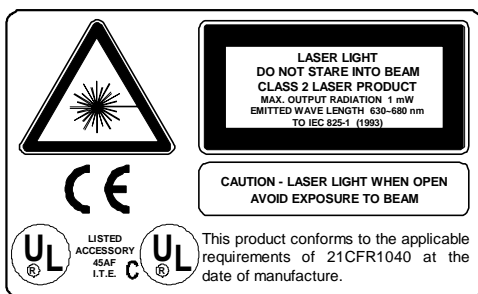
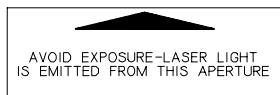

Warning and device class labels

Disconnect the power supply when opening the device during maintenance or installation to avoid exposure to hazardous laser light.



The laser diode used in this device is classified as a class 3B laser product according to IEC 825-1 regulations and as a Class IIIb laser product according to CDRH regulations. As it is not possible to apply a classification label on the laser diode used in this device, the following label is reproduced on the right.

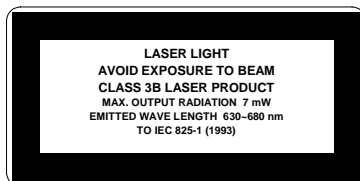

Laser diode class label

Any violation of the optic parts in particular can cause radiation up to the maximum level of the laser diode (7 mW at 630 to 680 nm).

POWER SUPPLY

- **This product is intended to be installed by Qualified Personnel only.**

- Models DS2400-XXX0:

This accessory device is intended to be supplied by a UL Listed Power Unit with «Class 2» or LPS power source which supplies power directly to the scanner via the 25-pin connector.

- Model DS2400-XXX1:

This accessory device is intended to be supplied via the Junction Box by an NEC Class 2 Power Source rated 10-30 V, minimum 0.55 A.

1 GENERAL FEATURES

1.1 INTRODUCTION

The DS2400 laser scanner satisfies the most advanced needs of a wide range of users. It has been developed focusing on the realistic requirements of its target market. The outstanding result is an extremely compact, cost-effective and easy to use industrial scanner.

C-Programmability The DS2400 belongs to the generation of Datalogic scanners that operate under the 'C' programming environment, which is a recognized industry standard.

Standard Application Program A standard application program is factory-loaded onto the DS2400. This program controls barcode reading, serial port interfacing, data formatting and many other operating and control parameters.

It is completely configurable from a host computer through the WinHost utility program provided on diskette with the scanner, or through ESC sequences via the serial interface.

Custom Application Programs If the Standard Application Program doesn't meet your requirements, please contact your local Datalogic distributor.

1.2 DESCRIPTION

Some of the main features of DS2400 are listed below:

- small dimensions and light weight.
- software programmable scanning speed (400 to 1000 scans/sec) on all models.
- linear and raster versions.
- connector and junction box versions.

- completely configurable via serial interface (WinHost™).
- 2 serial communication interfaces.
- supply voltage from 10 to 30 Vdc.
- reads all popular codes.
- test mode to verify the reading features and exact positioning of the scanner without the need for external tools.
- programmable in 4 different operating modes to suit the most various barcode reading system requirements.
- code verifier.

The DS2400 uses a solid state laser diode as a light source; the light emitted has a wavelength between 630 and 680 nm. Refer to the section “Safety precautions” at the beginning of this manual for information on laser safety.

The protection class of the enclosure is IP65, the reader is therefore suitable for industrial environments where high protection against harsh external conditions is required.

The four LEDs on the side of the scanner indicate the following:

PWR/TXD LED (red) (Figure A, ①) indicates the reader is connected to the power supply or, when blinking (green), data transmission.

GOOD READ LED (red) (Figure A, ③) is used to signal the possibility of a successful barcode reading.

EXT TRIG LED (yellow) (Figure A, ②) indicates external trigger activity. Refer to par. 2.4.4.

LASER ON LED (green) (Figure A, ④) indicates laser ON state.

The screw holes on the body of the reader are for mechanical fixture (Figure A, ⑧).

1.2 - General Features

1.3 AVAILABLE MODELS

The DS2400 scanner is available in versions that differ in regard to the following parameters:

- Reading range
- Serial interfaces
- Linear or raster reading
- Connections

The following models are therefore available:

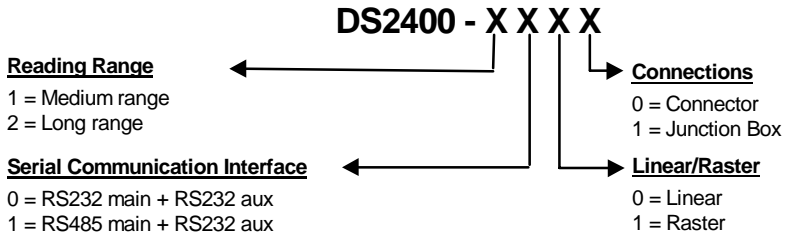

The following tables display each version's reading performance.

Version	Max Code Resolution	Speed
	mm (mils)	scans/s
1XXX	0.25 (10)	400 to 1000
2XXX	0.35 (14)	400 to 1000

Version	Reading Distance
1XXX	100 mm (4 in) - 440 mm (17 in) on 0.50 mm (20 mils) codes
2XXX	200 mm (8 in) - 600 mm (23.5 in) on 0.50 mm (20 mils) codes

See reading diagrams in par. 3.4 for further details.

1.4 ACCESSORIES

The following accessories are available on request for the DS2400:

- 90° deflection mirror GFC-2100
- 20 mA Current Loop interface INT-22

1.5 GFC-2100 ACCESSORY INSTALLATION

GFC-2100 is a 90° deflection mirror available on request for DS2400. The installation of the 90° deflection mirror is very easy (Figure 1.1).

CAUTION

Avoid any contact with the deflection mirror, mirrored rotor, the lenses or other optical components, otherwise the performance of the reader will be reduced.

1. Turn off the device.
2. Remove the DS2400 scanning window unscrewing the two cover screws.
3. Fix the mirror to the device by means of the two fixing screws.
4. Remount the scanning window so that the opening face is now at 90° with respect to the DS2400 body.

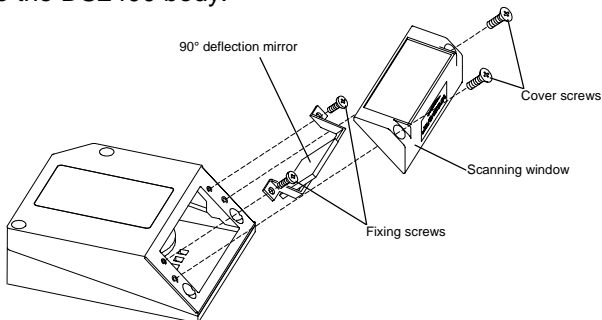

Figure 1.1 - Installation of the deflection mirror

1.4 - General Features

2 INSTALLATION

2.1 PACKAGE CONTENTS

Verify that the DS2400 reader and all the parts supplied with the equipment are present and intact when opening the packaging; the list of parts includes:

1. DS2400 reader with cable
2. Installation manual
3. Bar code test chart (PCS = 0.9)
4. DS2400 configuration program disk
5. Mounting kit: - bracket
 - screws

* Junction box (for DS2400-XXX1 models only), see par. 1.3.

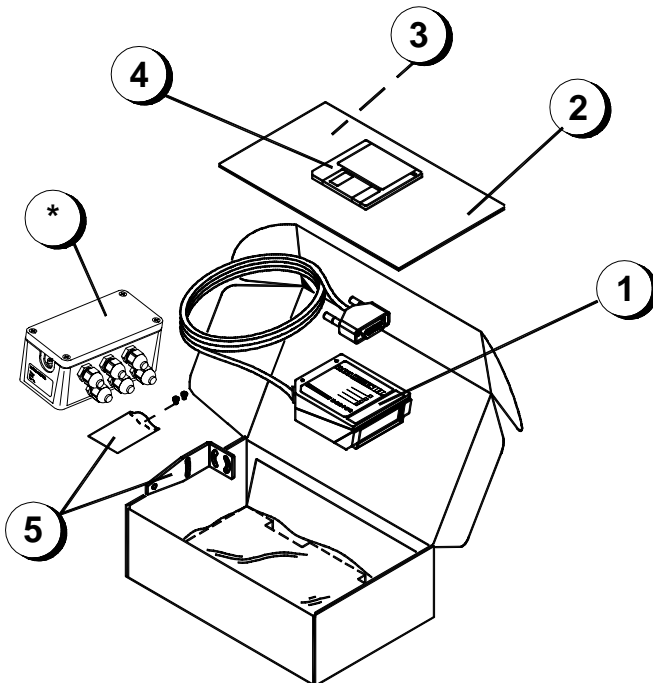

Figure 2.1 - DS2400 package contents

2.2 MECHANICAL INSTALLATION

DS2400 can be installed to operate in different positions. The four screw holes (M4 x 5) on the body of the reader are for mechanical fixture (Figure A, 5). The diagrams below give the overall dimensions of the scanner and mounting bracket and may be used for installation.

Refer to par. 2.5 for correct positioning.

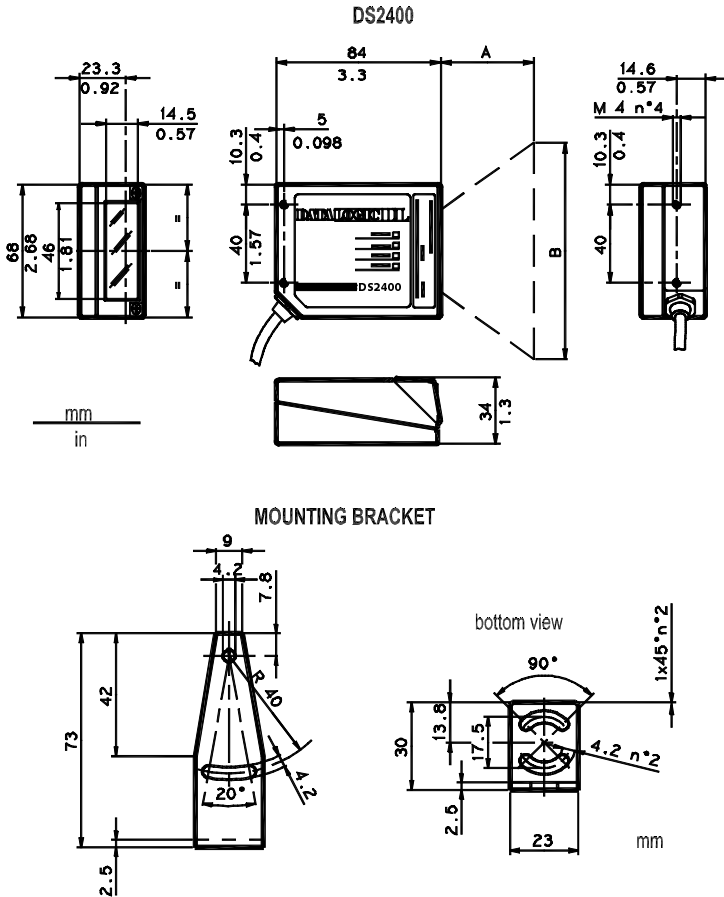

Figure 2.2 - DS2400 Overall dimensions

2.3 JUNCTION BOX INSTALLATION

The Junction Box provides a passive connection between your scanner and the outside world in a fast and practical way. It represents an alternative to the 25-pin connectors. Figure 2.3 shows the basic layout of a scanner using the junction box.

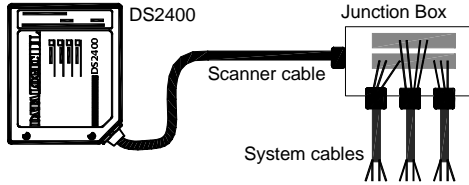

Figure 2.3 - Scanner using Junction Box

For Junction Box connections, the scanner has a cable that terminates in a 24 pin connector that plugs into the junction box. The system cables pass through 6 glands in the side of the Junction Box and the individual wires connect to spring clamp terminal blocks inside which provide access to all scanner signals.

2.3.1 Junction Box Mounting

The diagram below shows the dimensions of the Junction Box and its relative mounting holes.

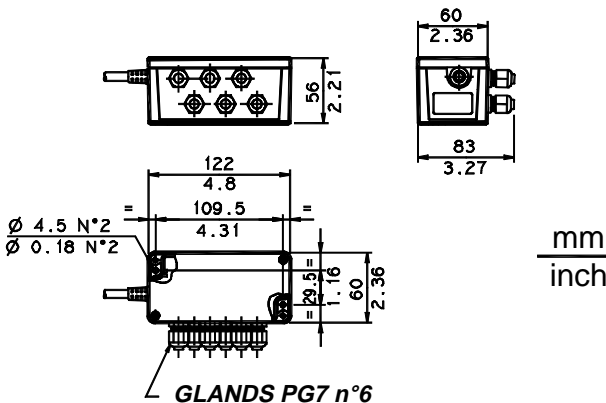

Figure 2.4 - Junction Box Overall dimensions

The Junction Box is designed to be mounted to a panel of metal, plastic or other appropriate material using the mounting screws provided in the package. To do this:

- 1) Open the junction box by unscrewing the 4 cover screws. If necessary, using the two mounting holes inside the junction box as a pattern, mark the panel with an appropriate object and then drill two small pilot holes in the panel.

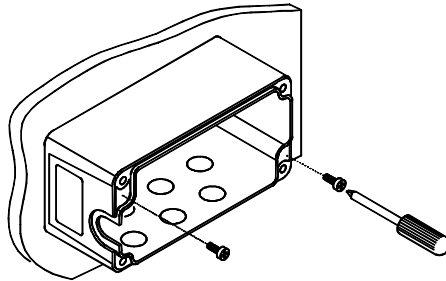

Figure 2.5 - Mounting Junction Box

- 2) Align the junction box and insert the two self-threading screws with their washers and screw them into the panel until tight (see Figure 2.5).

2.3.2 Junction Box Electrical Connections

The connection and wiring procedure for Junction Box is described as follows:

- 1) Open the junction box by unscrewing the 4 cover screws.
- 2) Pass all System cables through the glands in the junction box housing.
- 3) To connect the power and input/output signals:
 - Prepare the individual wires of the system cables by stripping the insulation back approximately 11 mm.
 - Using a device such as a screwdriver, push down on the orange lever directly above the clamp (see Figure 2.6).
 - Insert the wire into the clamp and release the lever.

The wire will now be held in the spring clamp.

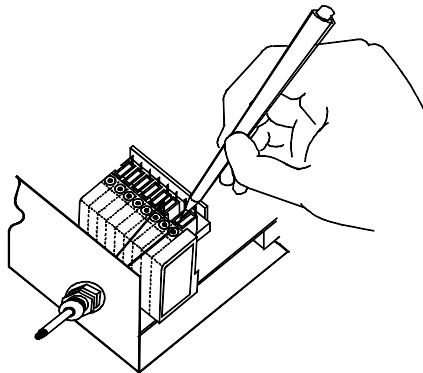

Figure 2.6 - System cable connections to the junction box

The wiring used can be solid or stranded but must meet the following specifications:

Positions 1-4:	24 - 16 AWG	0,2 - 1,5 mm ²
Positions 5-39:	26 - 20 AWG	0,14 - 0,5 mm ²

The junction box pinouts are indicated in the following table:

J. Box Pinout for DS2400	
Pin	Name
01	VS
02	GND
03	VS
04	GND
05	CHASSIS
06	VS
07	VS
08	EXT TRIG +
09	EXT TRIG -
10	GND
11	GND
12	VS
13	VS
14	N.C.
15	N.C.
16	GND
17	GND
18	OUT1 +
19	OUT REF
20	OUT2 +
21	N.C.
22	N.C.
23	N.C.
*24	Main interface signals see table below
*25	
*26	
27	N.C.
28	GND
29	Main interface signals see table below
30	
31	
32	
33	
34	GND
35	TXAUX
36	RTSAUX
37	GND
38	RXAUX
39	CTSAUX

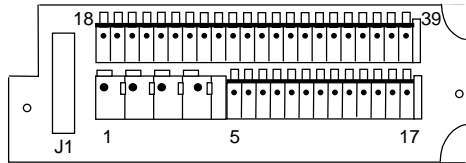

Figure 2.7 - Junction Box connector and pinout

To allow connection of an NEC Class 2 Power Unit, use a correct female plug adapter.

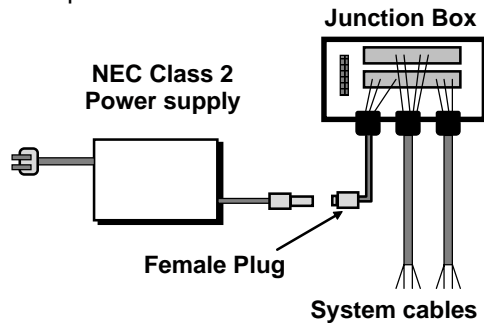

Figure 2.8 - NEC Class 2 Power unit connections

* The signals on pins 24, 25, and 26 are repeated on pins 29, 30, and 31 to facilitate network connections (i.e. Multiplexer using the RS485 Half-duplex interface). In this way the network bus can enter and exit the junction box from different spring clamps but be physically connected together.

Pin	RS232	RS485 Full-Duplex	RS485 Half-Duplex	20 mA C.L. (INT-22 Only)
24,29	TX232	TX485+	RTX485+	CL OUT+
25,30	RTS232	TX485-	RTX485-	CL OUT-
26,31	SGND	SGND	SGND	
32	RX232	RX485+		CL IN+
33	CTS232	RX485-		CL IN-

- 4) After wiring the junction box and while the scanner is unplugged from the power, place the Scanner cable so that the rubber seal fits into the cutout in the housing of the junction box and plug the 24 pin connector into connector J1 on the PCB inside the junction box as shown in Figure 2.9.

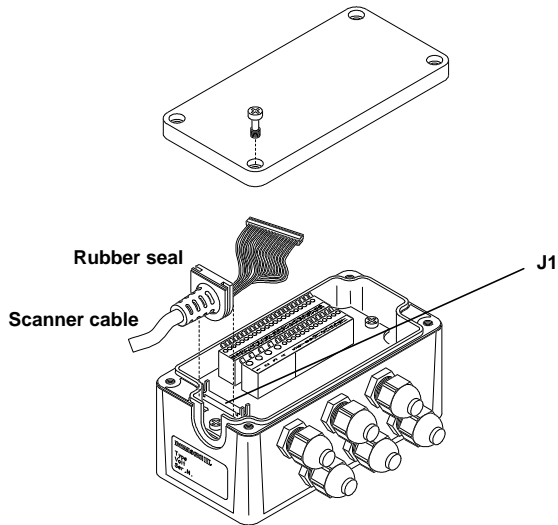

Figure 2.9 - Scanner cable connections to the junction box

- 5) Close the junction box using the 4 cover screws making sure the rubber seal is fitted correctly between the parts of the housing.

The junction box is now installed which completes the electrical connections for your scanning system.

If it ever becomes necessary to disconnect the scanner from the Junction Box, simply reverse the procedure in step 4.

2.4 ELECTRICAL CONNECTIONS

DS2400 25-pin connector models are equipped with a cable terminated by a 25-pin female D-sub connector for connection to the power supply and input/output signals.

The details of the connector pins are indicated in the following table:

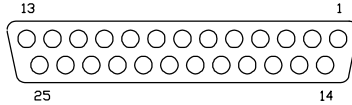

Figure 2.10 - 25-pin female D-sub connector

25-pin D-sub connector pinout					
Pin	Name	Function			
13	VS	Power supply input voltage +			
25	GND	Power supply input voltage -			
1	CHASSIS	Chassis Ground			
9	VS	External Trigger supply voltage +			
18	EXT TRIG+	External Trigger +			
19	EXT TRIG-	External Trigger -			
8	OUT1 +	Output 1 +			
11	OUT2 +	Output 2 +			
12	OUT REF	Output reference			
22	OUT REF	Output reference			
20	RXAUX	Auxiliary RS232			
21	TXAUX	Auxiliary RS232			
23	CTSAUX	Auxiliary handshake RS232			
24	RTSAUX	Auxiliary handshake RS232			
6, 10, 14, 15, 16, 17	NC	Not Connected			
Pin		RS232	RS485 Full-Duplex	RS485 Half-Duplex	20 mA C.L. (INT-22 Only)
2	Main interface signals, see par. 2.4.2.	TX232	TX485+	RTX485+	CLOUT+
3		RX232	RX485+		CLIN+
4		RTS232	TX485-	RTX485-	CLOUT-
5		CTS232	RX485-		CLIN-
7		SGND	SGND	SGND	

2.8 - Installation

2.4.1 Power Supply

Power can be supplied to the scanner through the pins provided on the 25-pin connector used for communication with the host:

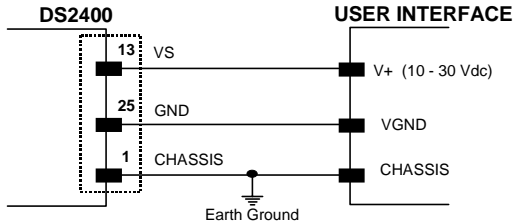

Figure 2.11 - Power supply connections

The power must be between 10 and 30 Vdc only.

It is recommended to connect pin 1 (CHASSIS) to a common earth ground.

2.4.2 Main Serial Interface

The signals relative to the following serial interface types are available on the input/output connector of DS2400 depending on the DS2400 model (see par. 1.3).

*If the interface type is not compatible with the current communication handshaking, then the system forces the handshake to **none**.*

The parameters relative to the interface selected (baud rate, data bits, etc.) can be defined using the WinHost utility program or "Host Mode" programming procedure through ESC sequences provided on diskette.

Details regarding the connections and use of the interfaces are given in the next paragraphs.

RS232 Interface

The serial interface is used in this case for point to point connections; it handles communication with the host computer and allows both transmission of code data and the programming of the scanner. This is the default setting.

The following pins are used for RS232 interface connection:

Pin	Name	Function
2	TX232	Transmitted Data
3	RX232	Received Data
4	RTS232	Request To Send
5	CTS232	Clear To Send
7	SGND	Signal Ground

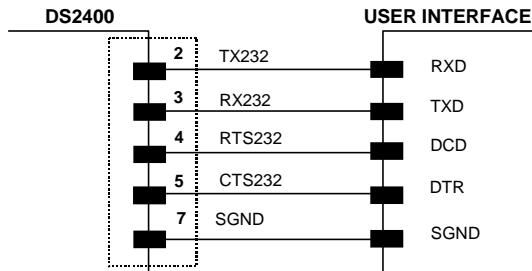

Figure 2.12 – RS232 main interface connections using hardware handshaking

The RTS232 and CTS232 signals control data transmission and synchronize the connected devices.

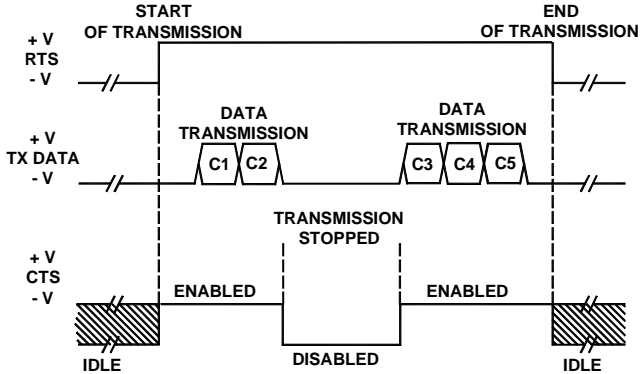

Figure 2.13 - RS232 control signals

If the RTS/CTS handshaking protocol is enabled, the DS2400 activates the RTS232 output to indicate a message is to be transmitted. The receiving unit activates the CTS232 input to enable the transmission.

RS485 Full-Duplex Interface

The RS485 full-duplex interface is used for non-pollled communication protocols in point to point connections over longer distances than those acceptable for RS232 communications or in electrically noisy environments.

The connector pinout follows:

Pin	Name	Function
2	TX485+	RS485 transmitted data +
4	TX485-	RS485 transmitted data -
3	RX485+	RS485 received data +
5	RX485-	RS485 received data -
7	SGND	Signal Ground

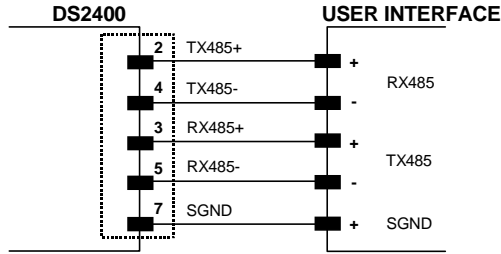

Figure 2.14 - RS485 full-duplex connections

RS485 Half-Duplex Interface

The RS485 half-duplex (3 wires + shield) interface is used for polled communication protocols.

It can be used in a master/slave layout or for Multidrop connections with a Datalogic Multiplexer, (see par. 2.6.4 and 2.6.5).

The connector pinout follows:

Pin	Name	Function
2	RTX485+	RS485 transmitted/received data +
4	RTX485-	RS485 transmitted/received data -
7	SGND	Signal Ground

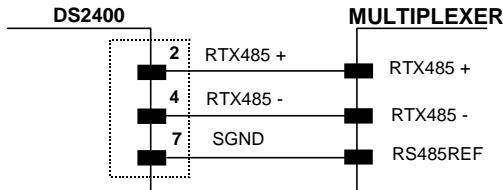

Figure 2.15 - RS485 half-duplex connections

This interface is forced by software when the protocol selected is MUX32 protocol.

In a Multiplexer layout or for slaves, the Multidrop address must also be set via serial channel by the WinHost utility or by ESC sequences.

2.12 - Installation

Figure 2.16 shows a multidrop configuration with DS2400 scanners connected to a Multiplexer.

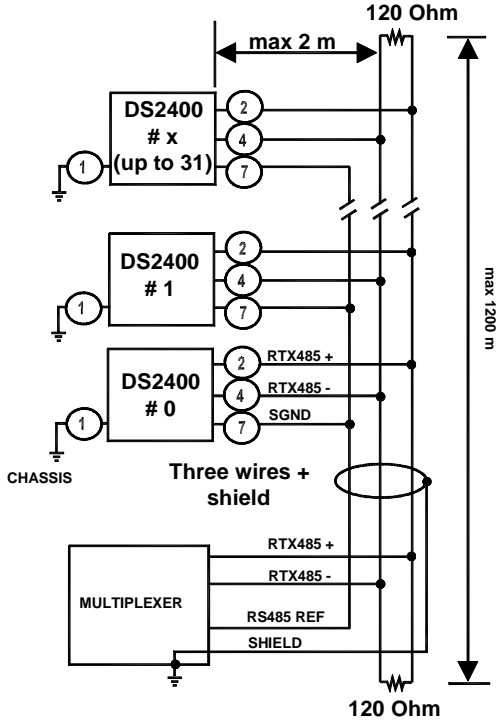

Figure 2.16 - DS2400 Multidrop connection to a Multiplexer

20 mA Current Loop Interface (INT-22 Accessory Only)

When the INT-22 accessory board is installed, the DS2400 is equipped with a 20 mA passive current loop interface.

The following pins of the 25-pin connector are used:

Pin	Name	Function
5	CLIN-	Current Loop Input -
3	CLIN+	Current Loop Input +
4	CLOUT-	Current Loop Output -
2	CLOUT+	Current Loop Output +

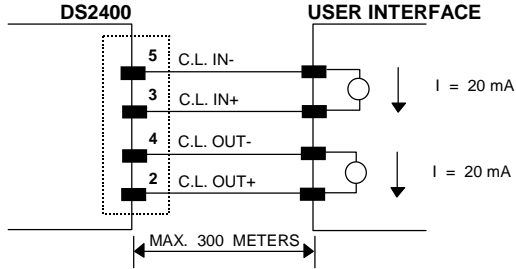

Figure 2.17 - 20 mA C.L. connections

2.4.3 Auxiliary RS232 Interface

The auxiliary serial interface is used exclusively for RS232 point to point connections.

The parameters relative to the aux interface (baud rate, data bits, etc.) as well as particular operating modes such as LOCAL ECHO can be defined using the WinHost utility program installed from the diskette or "Host Mode" programming provided on diskette.

The following pins of the 25-pin connector are used to connect the RS232 auxiliary interface:

Pin	Name	Function
20	RX232	Transmitted Data
21	TX232	Received Data
23	CTS232	Request To Send
24	RTS232	Clear To Send
7	SGND	Signal Ground

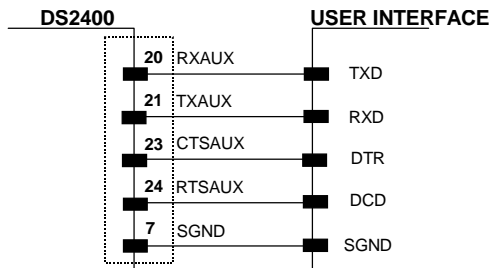

Figure 2.18 - RS232 auxiliary interface connections using hardware handshaking

The RTS/AUX and CTS/AUX signals control data transmission and synchronize the connected devices. If the RTS/CTS handshaking protocol is enabled, the DS2400 activates the RTS/AUX output to indicate a message is to be transmitted. The receiving unit activates the CTS/AUX input to enable the transmission.

2.4.4 Inputs

The inputs available on the connector supplied with the scanner are the pins relative to the External Trigger, as indicated below:

Pin	Name	Function
18	EXT TRIG+	External Trigger +
19	EXT TRIG-	External Trigger -

The External Trigger input is used in the On-Line Operating Mode and tells the scanner to scan for a code. The active state of this input is selected in software. Refer to the WinHost Help On Line.

The yellow LED (Figure A, ②) is on when the External Trigger forces a current flow through the EXT TRIG+ and EXT TRIG- pins.

This input is optocoupled and can be driven by both an NPN or PNP type command. The connections are indicated in the following diagrams:

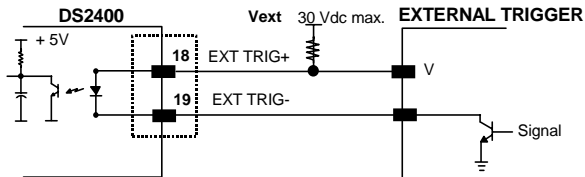

Figure 2.19 - Input NPN command using external power

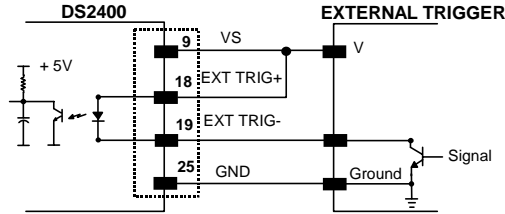

Figure 2.20 - Input NPN command using DS2400 power

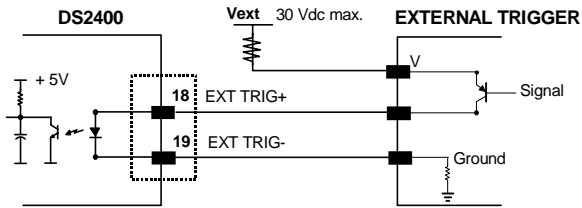

Figure 2.21 - Input PNP command using external power

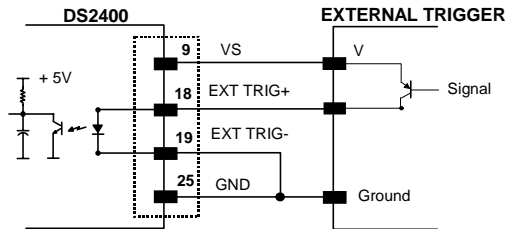

Figure 2.22 - Input PNP command using DS2400 power

Electrical features: Maximum voltage: 30 Vdc
Maximum current: 25 mA

An anti-disturbance hardware filter is implemented on the External Trigger input (about 1 millisecond delay).

An additional 15 ms (typical) delay can be implemented through a dedicated software parameter (refer to WinHost Help On Line).

2.16 - Installation

2.4.5 Outputs

There are two general purpose outputs. The following pins are present on the 25-pin connector of the scanner:

Pin	Name	Function
8	OUT1+	Output 1 +
22	OUT REF	Output reference
11	OUT2+	Output 2 +
12	OUT REF	Output reference

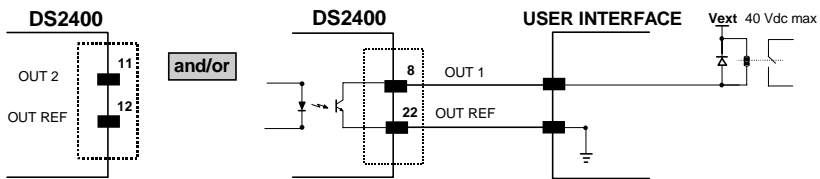

Figure 2.23 Output 1 / Output 2 connections

The meaning of the two outputs OUT1 and OUT2 can be defined by the user. Refer to the WinHost Help On Line.

By default, OUT1 is associated with the No Read event, which activates when the code signalled by the external trigger is not decoded, and OUT2 is associated with the Right event, which activates when the code is correctly decoded.

These outputs are both level or pulse configurable.

2.5 POSITIONING

The DS2400 scanner is able to decode moving barcode labels at a variety of angles, however significant angular distortion may degrade reading performance.

When mounting the DS2400 take into consideration these three ideal label position angles: **Pitch 0°, Skew 10° to 30° and Tilt 0°.**

Follow the suggestions for the best orientation:

The **Pitch** angle is represented by the value **P** in Figure 2.24. Position the reader in order to **minimize** the **Pitch** angle.

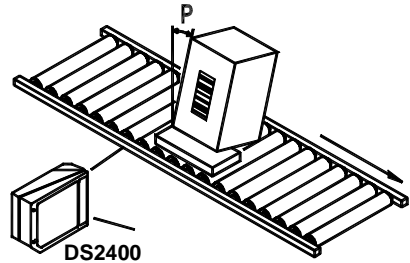

Figure 2.24 - Pitch Angle

The **Skew** angle is represented by the value **S** in Figure 2.25. Position the reader to **assure at least 10°** for the **Skew** angle. This avoids the direct reflection of the laser light emitted by the DS2400.

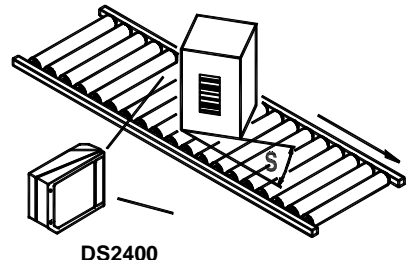

Figure 2.25 - Skew angle

For the raster version, this angle refers to the most inclined or external raster line, so that all other raster lines assure **more** than 10° Skew.

The **Tilt** angle is represented by the value **T** in Figure 2.26. Position the reader in order to **minimize** the **Tilt** angle.

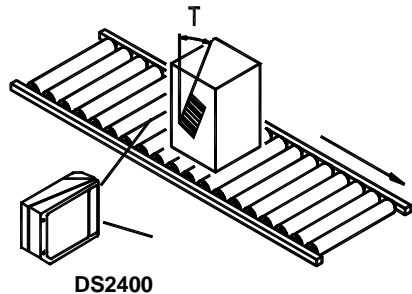

Figure 2.26 - Tilt angle

2.18 - Installation

2.6 TYPICAL LAYOUTS

The following typical layouts refer to system hardware configurations. Dotted lines in the figures refer to optional hardware configurations within the particular layout.

*These layouts also require the correct setup of the software configuration parameters. Complete software configuration procedures can be found in the **Guide To Rapid Configuration** in the WinHost Help On Line.*

2.6.1 Point-to-Point

In this layout the data is transmitted to the Host on the main serial interface. Host Mode programming can be accomplished either through the main interface or the auxiliary interface.

In Local Echo communication mode, data is transmitted on the RS232 auxiliary interface independently from the main interface selection.

When On-Line Operating mode is used, the scanner is activated by an External Trigger (photoelectric sensor) when the object enters its reading zone.

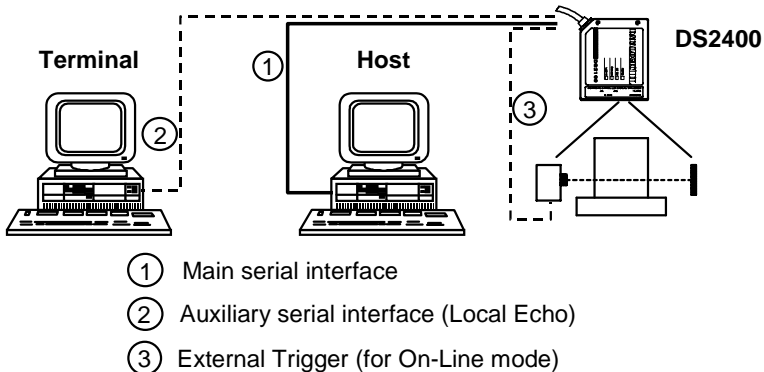

Figure 2.28 - Point-to-Point layout

2.6.2 Pass Through

Pass through mode allows two or more devices to be connected to a single external serial interface.

Each DS2400 transmits the messages received by the auxiliary interface onto the main interface. All messages will be passed through this chain to the host.

When On-Line Operating mode is used, the scanner is activated by an External Trigger (photoelectric sensor) when the object enters its reading zone.

The main and auxiliary ports are connected as shown in the figure below:

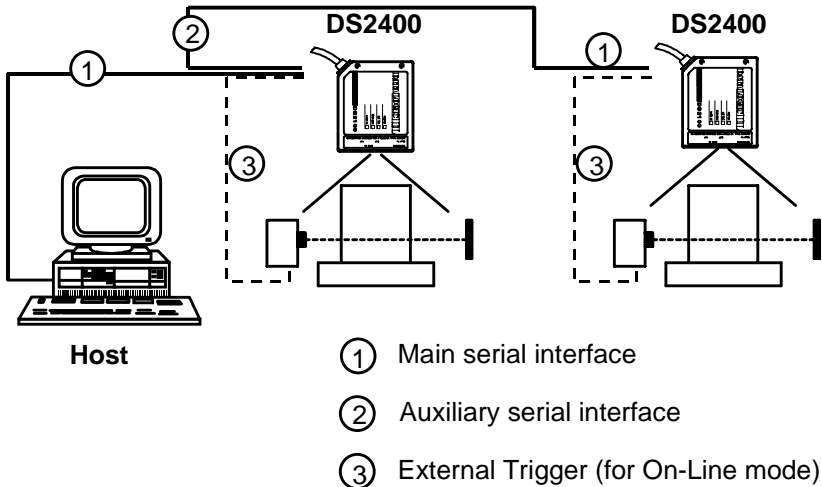

Figure 2.29 - Pass through layout

2.6.3 RS232 Master/Slave

The RS232 master/slave connection is used to collect data from several scanners to build either an multi-point or a multi-sided reading system; there can be one master and up to 9 slaves connected together.

The Slave scanners use RS232 only on the main and auxiliary serial interfaces. Each slave DS2400 transmits the messages received by the auxiliary interface onto the main interface. All messages will be passed through this chain to the master.

The master scanner is connected to the Host on the main serial interface. The possible main interface types for the Master scanner are RS232 or RS485. (20 mA C.L. can also be used if the INT-22 accessory is installed).

Either On-Line or Serial On-Line Operating modes can be used in this layout.

When On-Line Operating mode is used, the external trigger signal is unique to the system, however it is not necessary to bring the external trigger signal to the Slave scanners.

The main and auxiliary ports are connected as shown in the figure below.

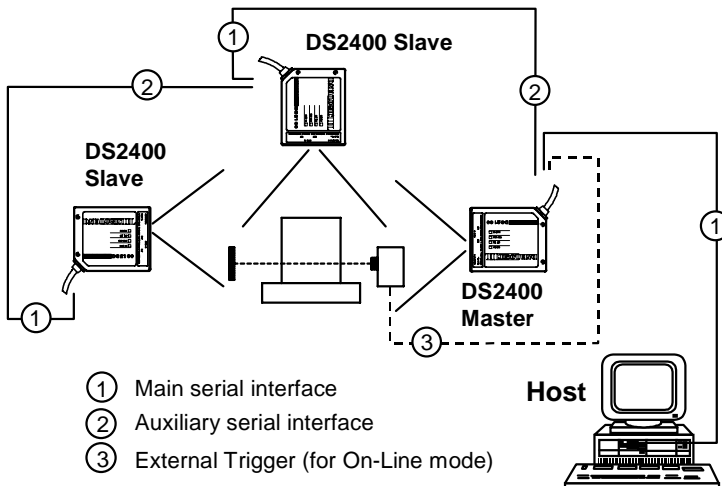

Figure 2.30 - RS232 Master/Slave layout

2.6.4 RS485 Master/Slave

The RS485 master/slave connection is used to collect data from several scanners to build either a multi-point or a multi-sided reading system; there can be one master and up to 5 slaves connected together.

The slave scanners are connected together using RS485 half-duplex on the main serial interface. Every slave scanner must have a multidrop address in the range 0-4.

The master scanner is also connected to the Host on the RS232 auxiliary serial interface.

The External Trigger signal is unique to the system; there is a single reading phase and a single message from the master scanner to the Host computer.

It is necessary to bring the External Trigger signal to all the scanners.

The main and auxiliary ports are connected as shown in the figure below.

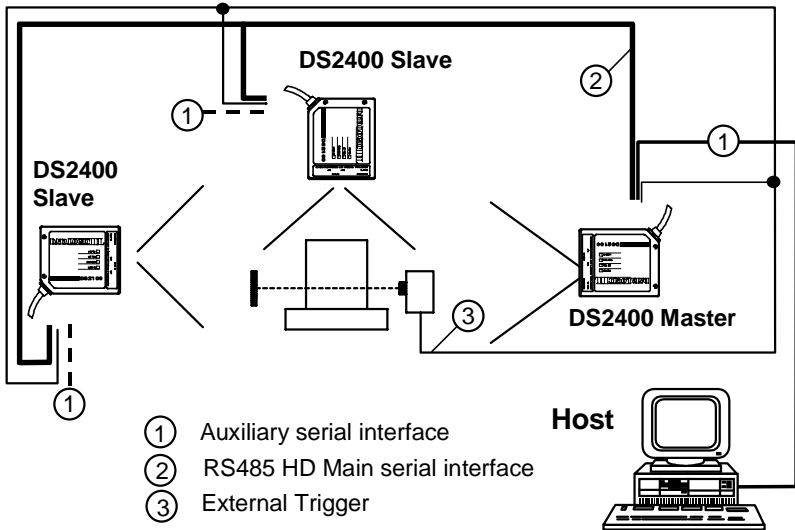

Figure 2.31 - RS485 Master/Slave layout

NOTE

The auxiliary serial interface of the slave scanners can be used in Local Echo communication mode to control any single scanner (visualize collected data) or to configure it using the WinHost utility or Host Mode Programming procedure.

The termination resistors of the RS485 bus must not be installed.

2.6.5 Multiplexer

Each scanner is connected to Multiplexer (for example MX4000) with the RS485 half-duplex main interface.

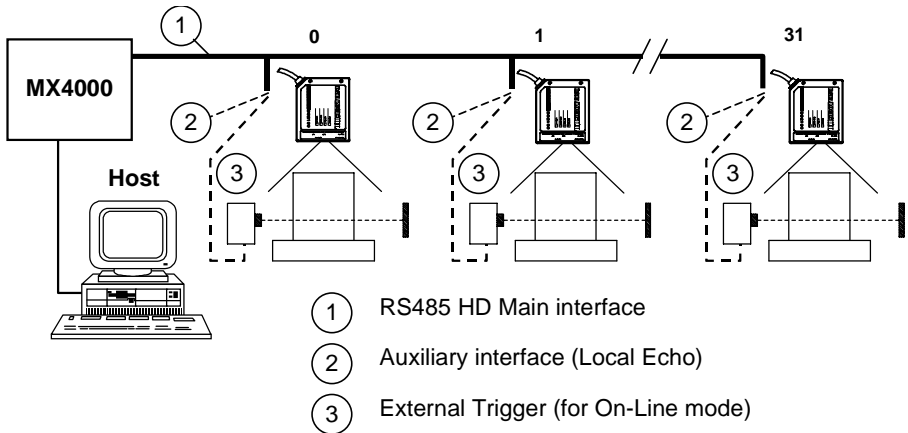

Figure 2.32 - Multiplexer layout

The auxiliary serial interface of the slave scanners can be used in Local Echo communication mode to control any single scanner (visualize collected data) or to configure it using the WinHost utility or Host Mode Programming procedure.

When On-Line Operating mode is used, the scanner is activated by an External Trigger (photoelectric sensor) when the object enters its reading zone.

This page is intentionally left blank.

2.24 - Installation

3 READING FEATURES

The number of scans performed on the code by the DS2400 and therefore the decoding capability is influenced by the following parameters:

- number of scans per second
- code motion speed
- label dimensions
- scan direction with respect to code motion

About 5 scans during the code passage should be allowed to ensure a successful read.

3.1 STEP-LADDER MODE

If scanning is perpendicular to the code motion direction (Figure 3.1 - "step-ladder" mode), the number of effective scans performed by the reader is given by the following formula:

SN = [(LH/LS) * SS] - 2 Where: SN = number of effective scans
 LH = label height (in mm)
 LS = label movement speed in (mm/s)
 SS = number of scans per second

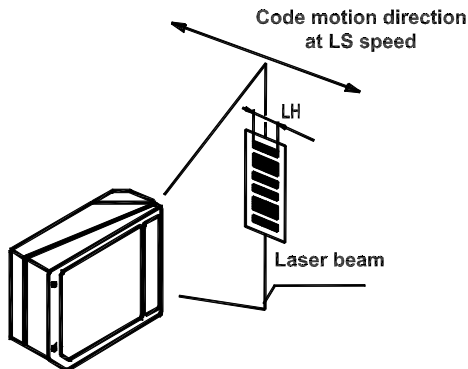

Figure 3.1 - "Step-Ladder" scanning mode

For example, the DS2400 (800 scans/sec.) for a 25 mm high code moving at 1250 mm/s performs:

$$[(25/1250) * 800] - 2 = 14 \text{ effective scans.}$$

3.2 PICKET-FENCE MODE

If scanning is parallel to the code motion, (Figure 3.2 - "picket-fence" mode), the number of effective scans is given by the following formula:

$$SN = [((FW-LW)/LS) * SS] - 2$$

Where: SN = number of effective scans
 FW = reading field width (in mm)
 LW = label width (in mm)
 LS = label movement speed (in mm/s)
 SS = scans per second

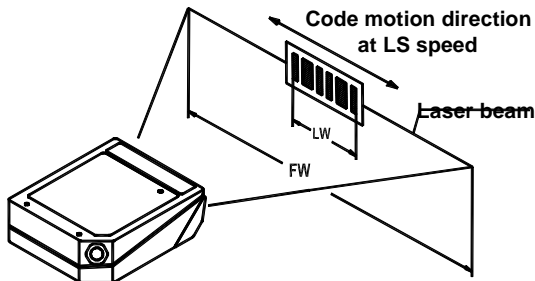

Figure 3.2 - "Picket-Fence" scanning mode

For example, for a 100 mm wide code moving in a point where the reading field is 200 mm wide at a 2000 mm/s speed, the DS2400 (800 scans per sec.), performs:

$$[((200-100)/2000) * 800] - 2 = 38 \text{ scans}$$

3.3 PERFORMANCE

The DS2400 scanner is available in different versions according to the reading performance.

Version	Max Code Resolution	Speed
	mm (mils)	scans/s
1XXX	0.25 (10)	400 to 1000
2XXX	0.35 (14)	400 to 1000

Version	Reading Distance
1XXX	100 mm (4 in) - 440 mm (17 in) on 0.50 mm (20 mils) codes
2XXX	200 mm (8 in) - 600 mm (23.5 in) on 0.50 mm (20 mils) codes

Refer to the diagrams given in par. 3.4 for further details on the reading features. They are taken on various resolution sample codes at a 25 °C ambient temperature, depending on the conditions in the notes under the diagrams.

3.3.1 Raster

Raster versions are available. If standard devices do not satisfy specific requirements, contact your nearest Datalogic distributor, supplying code samples, to obtain complete information on the reading possibilities.

The max. capture of the Raster version is 24 mm (0.95 inch) at 500 mm (20 inch).

3.4 READING DIAGRAMS

DS2400-1XXX (Medium Reading Range)

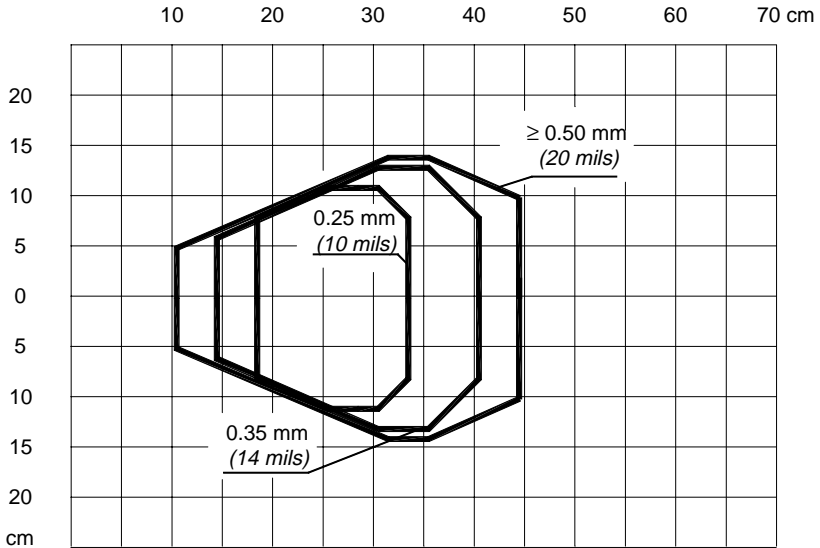

NOTE

(0,0) is the center of the laser beam output window.

CONDITIONS

- Code = Interleaved 2/5 or Code 39
- PCS = 0.90
- "Pitch" angle = 0°
- "Skew" angle = 10°
- "Tilt" angle = 0°
- Code Resolution* = High – for 0.25 mm (10 mils) codes and 0.35 mm, (14 mils) codes
Standard – for 0.50 mm (20 mils) codes and greater
- Code Reading Condition* = Standard
- Scanning Speed* = Speed_3 (800 scans/sec)

* Parameters selectable in WinHost.

3.4 - Technical Features

DS2400-2XXX (Long Reading Range)

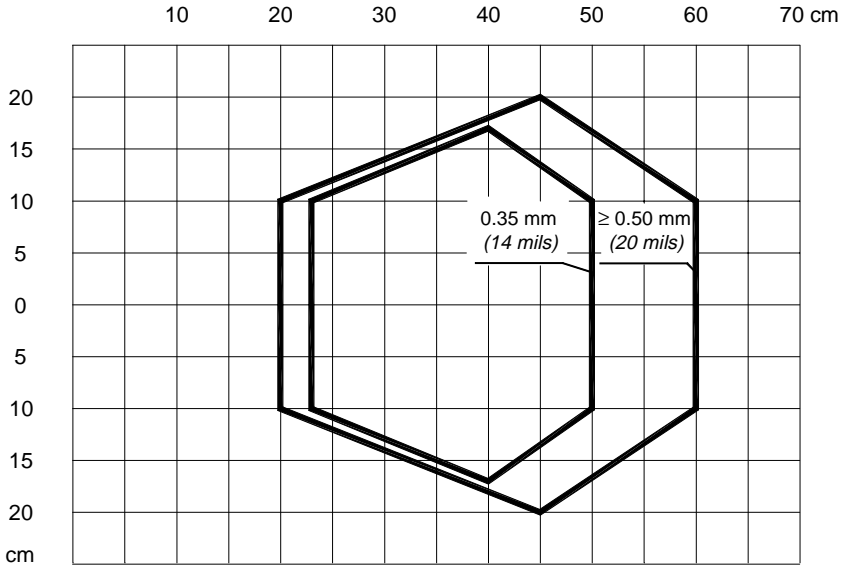

NOTE

(0,0) is the center of the laser beam output window.

CONDITIONS

- Code = Interleaved 2/5 or Code 39
- PCS = 0.90
- "Pitch" angle = 0°
- "Skew" angle = 10°
- "Tilt" angle = 0°
- Code Resolution* = High - for 0.35 mm (14 mils) codes
Standard - for 0.5 mm (20 mils) codes and greater
- Code Reading Condition* = Standard
- Scanning Speed* = Speed_3 (800 scans/sec)

* Parameters selectable in WinHost.

This page is intentionally left blank.

3.6 - Technical Features

4 MAINTENANCE

4.1 CLEANING

Clean the laser beam output window periodically for continued correct operation of the reader.

Dust, dirt, etc. on the window may alter the reading performance.

Repeat the operation frequently in particularly dirty environments.

Use soft material and alcohol to clean the window and avoid any abrasive substances.

WARNING

Clean the window of the DS2400 when the scanner is turned off or, at least, when the laser beam is deactivated.

This page is intentionally left blank.

4.2 - Technical Features

5 TECHNICAL FEATURES

	DS2400-1XXX	DS2400-2XXX
ELECTRICAL FEATURES		
Input Power		
Supply voltage	10 to 30 Vdc	
Power consumption max.	5 W	
Serial Interfaces (depends on model)		
Main	RS232; RS485 Full-duplex / Half-duplex; 20 mA C.L. (20 mA C.L. only with INT-22 accessory)	
Auxiliary	RS232	
Baud Rates	150 to 115200	
Inputs		
External Trigger	(optocoupled NPN or PNP)	
Voltage max.	30 Vdc	
Input current max.	25 mA	
Outputs		
OUT1, OUT2	(optocoupled)	
V _{CE} max.	40 Vdc	
Collector current max.	40 mA continuous; 130 mA pulsed	
V _{CE} saturation	1V at 10 mA max.	
Power dissipation max.	90 mW at 40 °C (Ambient temp.)	
OPTICAL FEATURES		
Light source	Semiconductor laser diode	
Wave length (Note 1)	630 to 680 nm	
Safety class	Class 2 - IEC 825-1; Class II - CDRH	
READING FEATURES (Note 2)		
Scan rate	software programmable (400 to 1000 scans/sec)	
Aperture angle	50°	
Maximum Reading distance	440 mm (17 inch)	600 mm (23.5 inch)
Maximum resolution	0.25 mm (10 mils)	0.35 mm (14 mils)
USER INTERFACE		
LED indicators	Laser ON, Good Read, External Trigger, Data TX / power ON	

SOFTWARE FEATURES	
READABLE CODE SYMBOLOGIES <ul style="list-style-type: none"> • EAN/UPC (including Add-on 2 and Add-on 5) • 2/5 Interleaved • Code 39 (Standard and Full ASCII) • Codabar • Code 93 • Code 128 • EAN 128 • Pharmacode Other symbologies available on request.	
Code Selection	up to six different codes during one reading phase
Decoding Safety	can enable multiple good reads of same code
Headers and Terminators	up to four headers and four terminators
Operating Modes	On-Line, Automatic, Serial-On-Line, Test
Configuration Modes	<ul style="list-style-type: none"> • through menus using WinHost utility • receiving commands from one of the serial ports (HOST MODE)
Parameter Storage	Non-volatile internal EEPROM
ENVIRONMENTAL FEATURES	
Operating temperature (Note 3)	0 to 40 °C (32 to 104 °F)
Storage temperature	-20 to 70 °C (-4 to 158 °F)
Humidity max.	90% non condensing
Vibration resistance	IEC 68-2-6 test FC 1.5 mm; 10 to 55 Hz; 2 hours on each axis
Shock resistance	IEC 68-2-27 test EA 30G; 11 ms; 3 shocks on each axis
Protection class	IP65
PHYSICAL FEATURES	
Mechanical dimensions	68 x 84 x 34 mm
Weight	330 g.

Note 1: The features given are typical at a 25 °C ambient temperature (if not otherwise indicated).

Note 2: Further details given in par. 3.3.

Note 3: *If the reader is used in high temperature environments (over 35 °C), use of the Beam-shutter is advised (see the WinHost configuration program).*

5.2 - Technical Features

Free Manuals Download Website

<http://myh66.com>

<http://usermanuals.us>

<http://www.somanuals.com>

<http://www.4manuals.cc>

<http://www.manual-lib.com>

<http://www.404manual.com>

<http://www.luxmanual.com>

<http://aubethermostatmanual.com>

Golf course search by state

<http://golfingnear.com>

Email search by domain

<http://emailbydomain.com>

Auto manuals search

<http://auto.somanuals.com>

TV manuals search

<http://tv.somanuals.com>