

Definitive Technology[®]
The Leader in High-Performance Loudspeakers[®]

BP7000sc/BP7001sc

Bipolar Loudspeaker with Built-In Powered SuperCube[®] Technology Subwoofers

Owner's Manual

Congratulations

Congratulations on your purchase of the Definitive Technology BP7000SC/BP7001SC Bipolar Loudspeaker System. The BP7000SC/BP7001SC are very unique speakers which combine our award-winning patented bipolar technology with a built-in side-firing SuperCube Technology subwoofer system complete with ultra-high power digital amplifiers. These extraordinary speakers truly revolutionize the state-of-the-art in music and home theater loudspeakers.

Our engineers have spent many years in developing this product. In order to ensure that you experience the finest performance possible, we encourage you to take a moment to fully read this owner's manual and familiarize yourself with the proper installation and set-up procedures for your BP7000SC/BP7001SC speakers.

Safety Precautions



CAUTION! To reduce the risk of electric shock and fire, do not remove the cover or back plate of this device. There are no user serviceable parts inside. Please refer all servicing to licensed service technicians. Avis: Risque de choc électrique, ne pas ouvrir.

CAUTION! The international symbol of a lightning bolt inside a triangle is intended to alert the user to uninsulated “dangerous voltage” within the device’s enclosure. The international symbol of an exclamation point inside a triangle is intended to alert the user to the presence of important operating, maintenance and servicing information in the manual accompanying the device.

CAUTION! To prevent electrical shock, match wide blade of plug to wide slot, fully insert. Attention: Pour éviter les chocs électriques, introduire la lame la plus large de la fiche dans la borne correspondante de la prise et pousser jusqu’au fond.

CAUTION! To reduce the risk of electrical shock, do not expose this equipment to rain or moisture.

1. Read Instructions—All safety and operating instructions should be read before operating the device.
2. Retain Instructions—The safety and operating instructions should be retained for future reference.
3. Heed Warnings—All warnings on the device and in the operating instructions should be adhered to.
4. Follow Instructions—All operating and safety instructions should be followed.
5. Water & Moisture—The device should never be used in, on or near water for risk of fatal shock.
6. Carts & Stands—The device should only be used on carts or stands recommended by the manufacturer.
7. Wall & Ceiling Mounting—The device should be mounted on a wall or ceiling only as recommended by the manufacturer.
8. Ventilation—The device should always be located in such a way that it maintains proper ventilation. It should never be placed in a built-in installation or anywhere that may impede the flow of air through its heat sink.
9. Heat—Never locate the device near heat sources such as radiators, floor registers, stoves or other heat-generating devices.
10. Power Supply—The device should only be connected to a power supply of the type described in the operating instructions or as marked on the device.
11. Power Cord Protection—Power cables should be routed so they are not likely to be stepped on or crushed by items placed on them or against them. Special attention should be paid to areas where the plug enters a socket or fused strip and where the cord exits the device.
12. Cleaning—The device should be cleaned in accordance with manufacturer’s instructions.
13. Periods Of Non-Use—The device should be unplugged when not being used for extended periods.
14. Dangerous Entry—Care should be taken that no foreign objects or liquids fall or are spilled inside the device.
15. Damage Requiring Service—The device should be serviced by licensed technicians when:
 - The plug or power supply cord has been damaged.
 - Objects have fallen or liquid has spilled inside the device.
 - The device has been exposed to moisture.
 - The device does not appear to be operating properly or exhibits a marked change in performance.
 - The device has been dropped or the cabinet becomes damaged.
16. Service—The device should always be serviced by licensed technicians. Only replacement parts specified by the manufacturer should be used. The use of unauthorized substitutions may result in fire, shock, or other hazards.

CAUTION Important Safety Instructions

To reduce the risk of the product inadvertently tipping over, four stabilizer brackets with mounting screws have been supplied. These must be installed in the base of the product in the slots provided.

Installation Instructions:

Tools required: Philips screw driver (not supplied)

Parts required: Four stabilizer brackets (supplied), eight screws (supplied)

Instructions:

1. Carefully lay the speaker on its front surface.
2. Place one of the stabilizer brackets in the rear slot provided. (Note: Stabilizer bracket will be flush with bottom of base.)

3. Insert two screws provided and tighten them securely, being careful not to strip out material.
4. Repeat steps #2 and #3 for the other stabilizer brackets.
5. Remove the supporting feet closest to the stabilizer brackets and thread them into the brass insert in the stabilizer brackets.
6. Carefully return the speaker to the upright position and adjust the glides (supporting feet) to level the speaker.

Note: If desired, the four glides (support feet) may be replaced and the four spikes provided may be installed. The four spikes or glides must be fully threaded into the brass inserts on the stabilizer brackets.

AVERTISSEMENT Mesures de Sécurité Impo

Pour réduire les risques que le produit se renverse par inadvertance, quatre supports stabiliseurs avec vis de montage ont été fournis. Ceux-ci doivent être installés sur la base du produit, dans les rainures appropriées.

Procédures d'installation:

Outils requis: Tournevis étoile (non fourni)

Pièces requises: Quatre supports stabiliseurs (fournis), huit vis (fournies)

Instructions:

1. Coucher soigneusement le haut-parleur sur la face avant.
2. Placer un des supports stabiliseurs dans la rainure appropriée arrière. (Note: le support stabiliseur sera égal au bas de la base)
3. Insérer deux des vis prévues à cet effet et serrer de façon ajustée en prenant garde de ne pas éliminer les parois du matériel.
4. Répéter les étapes #2 et #3 pour l'autre support stabiliseur.
5. Retirer les niveleurs (pieds de support) les plus rapprochés des supports stabiliseurs et visser les niveleurs, dans l'encolure de cuivre des supports stabiliseurs.
6. Relever soigneusement le haut-parleur dans sa position fonctionnelle et ajuster les niveleurs (pieds de support) pour équilibrer le haut-parleur.

Note: Les quatre niveleurs (pieds de support) peuvent être remplacés, si désiré, par les quatre pointes fournies à cet effet.

Unpacking Your BP7000sc/BP7001scs

Please Inspect For Shipping Damage

Each loudspeaker leaves our plant in perfect condition. Any visible or concealed damage most likely occurred in handling after it left our plant and should be reported at once to your Definitive dealer or the delivery company that delivered your loudspeaker. Please unpack your system carefully. Save all cartons and packing materials in case you move or need to ship your system. Record the serial number found on the back of the BP7000sc/BP7001sc in the appropriate place on your warranty card, answer all questions and send it in.

Positioning the Speakers in Your Room

It is important, because of the BP7000sc/BP7001sc's unique bipolar (front and rear) radiation pattern, that some simple set-up recommendations be followed in order to assure optimum performance in your room. Please remember that although these recommendations are usually valid, all rooms and listening set-ups are somewhat unique, so do not be afraid to experiment with the speakers. Remember, whatever sounds best to you is correct.

In most rooms the speakers should be placed 5 to 36 inches from the rear wall in order to allow the rear radiated sound to freely reflect off the back wall. Please note that they can go closer to, or further from, the wall if desired. Placement closer to the rear wall will increase the bass output while placement further from the rear wall will decrease the bass output (which, of course, can be compensated

for with the speakers' low frequency controls). Sometimes placement further from the rear wall will increase spaciousness and the sense of depth.

The speakers should usually be placed a minimum of 5 to 7 feet apart and kept away from the side walls and corners if possible. A good rule of thumb is to place the speakers separated by one half the length of the wall they are positioned along, and each speaker one quarter the length of the back wall away from the side wall.

Speakers may be angled in toward the listening position or left parallel with each other. Angling the speakers in (pointed directly at the listener) will result in a somewhat brighter, clearer sound with a sharper focus and a more solid central image (generally, we recommend this), while leaving the speakers parallel with each other will result in a less bright, more diffuse sound. Try to leave the space on the sides of the speakers as open and unobstructed as possible so that there will be no interference with the rear radiated sound.

The BP7000SC/BP7001SCs are mirror imaged (packing cartons are labeled speaker 1 and speaker 2) with a flat-coned radiator on the bottom of each side and one active driver around waist-high (which you can feel through the grille cloth). The side-mounted subwoofers are located so they may be set up with both waist high active woofers facing in (toward each other) or both active woofers facing out (away from each other). (Feel the side of the speakers about waist high to determine which side the woofer is on.) Facing the active woofers in or out will vary the sound somewhat and which way is best will vary with your room. Usually, we start with the active woofers facing in as this is often the way it sounds best. Again, experiment to determine the best location for the speakers. Often, adjusting the spikes or feet of the BP7001SC so that the front of the speaker is approximately 1/2" to 3/4" higher than the rear will provide better sound.

"Spiking" Your Loudspeakers

An optional "spiking" kit has been provided should you desire to "spike" your loudspeakers. "Spiking" your loudspeakers will provide greater stability when placing your loudspeakers on carpeting and will also, according to many experts, result in an overall improvement in sonic performance. Care should be taken when using spikes as they may cause damage to wooden or other floors which are susceptible to being scratched. Definitive Technology is specifically not responsible for damage which may result from the use of spikes.

The spike kit contains four spikes. To install, unscrew the plastic guides on the stabilizer brackets. Then screw the four spikes into the brass inserts on the stabilizer brackets. Then, with the help of another person, lift the speaker upright and lower it to its exact desired position on the floor. You must lower the speaker to the exact position you want because once the spikes are in place you cannot move the speakers sideways on the rug or floor – this may damage the floor or the speakers. Next, adjust the spikes so the speaker sits solidly on all four spikes (and does not rock).

Speaker Break-In

Your BP7000SC/BP7001SCs should sound good right out of the box; however, an extended break-in period of 40-60 hours or more of normal playing is required to reach full performance capability. Break-in allows the suspensions to work in and results in fuller bass, a more open “blossoming” midrange and smoother high frequency reproduction.

Connecting Your Loudspeakers

Connecting Your Speakers to Your Electronics

Your BP7000SC/BP7001SCs may be connected in several different ways. There are two sets of speaker level (high level) 5-way binding posts. In addition, each speaker has an LFE input. This input can be used with Dolby Digital* and DTS* 5.1 (6.1, 7.1) decoders to separately feed the discrete “Low Frequency Effects” channel into each subwoofer (which then combines with the low bass present separately in the left or right channel signals). If desired, you may hook up your BP7000SC/BP7001SCs simply by running one set of speaker wires from your amplifier to each BP7000SC/BP7001SCs, or as complexly as bi-wiring the low/mid- and high-frequency section of each BP7000SC/ BP7001SCs in conjunction with running a separate low-level input to the LFE input of the subwoofer section of each speaker. Your BP7000SC/BP7001SCs will deliver exceptional performance no matter which hook-up method you use. The more complex methods are often chosen by advanced hobbyists to extract the last 1% of performance potential from the speakers, while most listeners use the simplest hook-ups which also deliver superb performance. Unlike a conventional system, where the subwoofer is driven only by an LFE subwoofer signal, the BP7000SC/ BP7001SCs are much more sophisticated and are driven by the left or right channel signal as well as the LFE signal. For optimum performance, please read through these instructions fully and follow them.

* Registered Trademarks.

Rear Panel

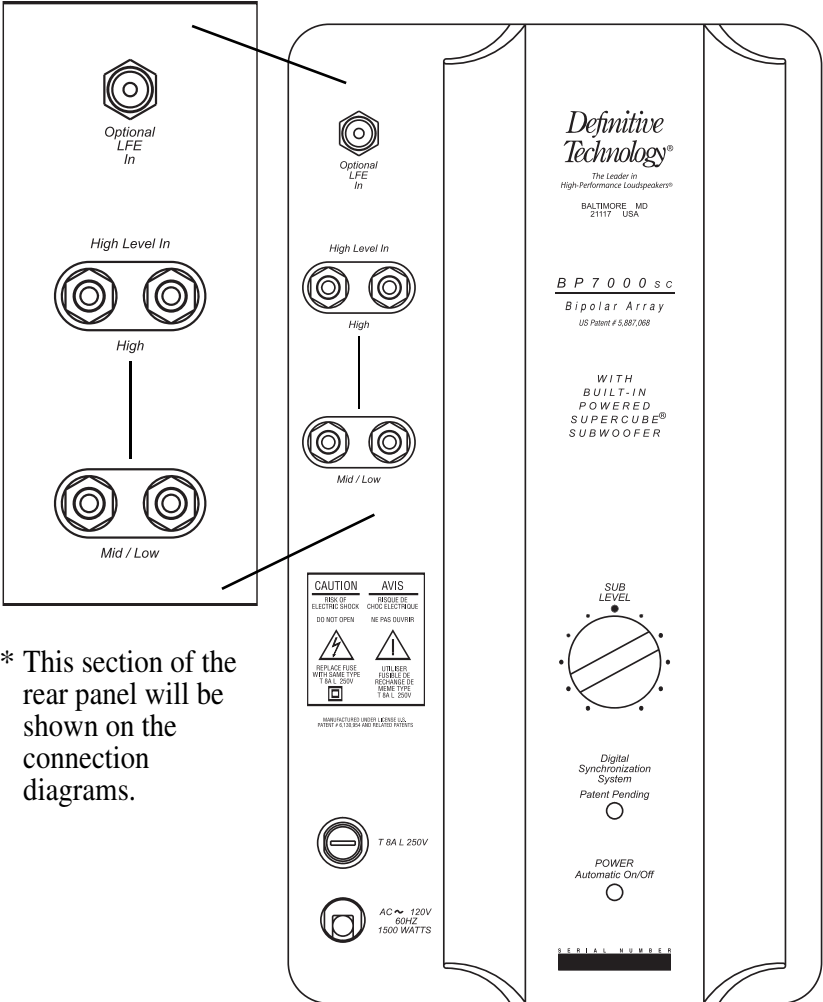

* This section of the rear panel will be shown on the connection diagrams.



Gold Jumper

Connecting Each Speaker with One Pair of Speaker Wires Only

With all the gold jumpers in place (see Diagram # 1), simply connect any of the red (+) terminals of each speaker to the red (+) terminal of its channel on your amplifier or receiver, and any of the black (-) terminals of each speaker to the black (-) terminal of its channel on your amplifier or receiver. It is essential that both speakers be connected in the same way (in phase) to its own channel of the amplifier. If you experience a great lack of bass, it is likely that one speaker is out of phase with the other.

If you have a Dolby Digital system, “tell” your bass management system that you have “Large” left and right front speakers and “No” subwoofer. The base management system will then send the LFE .1 channel signal into the left and right channels, and it will be reproduced by the subwoofers in your BP7000sc/ BP7001SCs, giving you all the benefits of Dolby Digital and the discrete LFE signal.

When the speakers are hooked up using simply one set of speaker wire per speaker (with no separate low level input for the subwoofer section), a special circuit takes an infinitesimally small signal from the speaker level input and converts it to a low-level signal which then drives the subwoofer power amp.

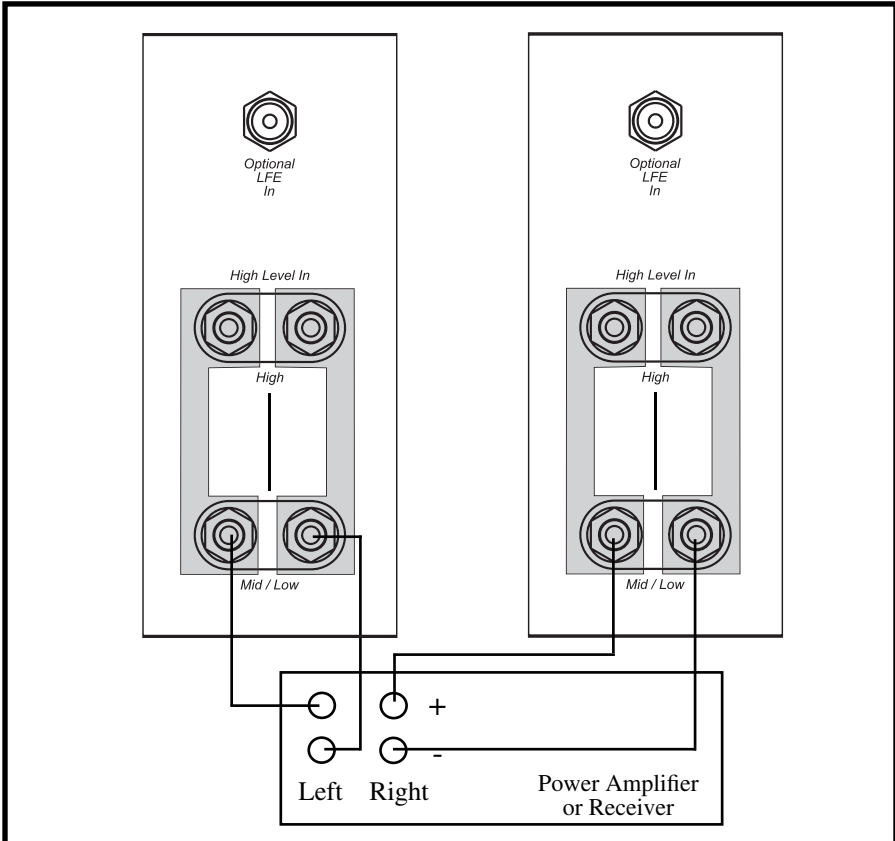

Diagram # 1: Connecting Each Speaker with One Pair of Speaker Wires Only

Bi-Wiring

The concept of bi-wiring is that higher sonic performance (greater inner detail, higher definition, increased transparency and improved depth) is achieved by utilizing two sets of wires to connect each loudspeaker to its respective channel of your amplifier or receiver.

If you choose this method of hook-up, follow these instructions:

For bi-wiring: (See Diagram # 2) Remove both the jumpers between the low/mid and high terminals on each speaker. Then take care to ensure that both the red (+) high and red (+) mid terminals of the left speaker are connected to the red (+) terminal of the left channel of your amplifier (each using one conductor of each of the two sets of wires for the left channel) and that both the black (-) high and black (-) low/mid terminals of the left speaker are connected to the black (-) terminal of the left channel of your amplifier using the other conductor of each of the two sets of wires for the left channel. Utilize the same hook-up procedure for the right channel.

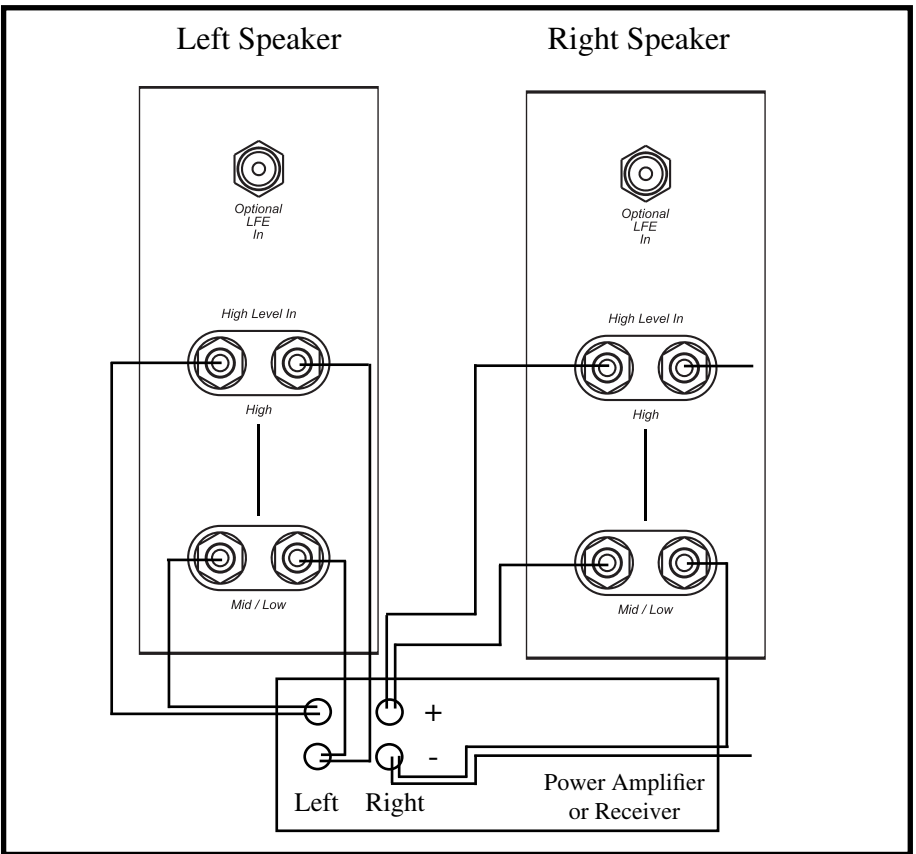

Diagram # 2: Bi-Wiring

If you have a Dolby Digital system, “tell” your bass management system that you have “Large” left and right front speakers and “No” subwoofer. The base management system will then send the LFE .1 channel signal into the left and right channels, and it will be reproduced by the subwoofers in your BP7000SC/ BP7001SCs, giving you all the benefits of Dolby Digital and the discrete LFE signal.

Usually if distortion is heard when the speakers are being driven at loud levels, it is caused by driving (turning up) the amplifier too loud and not driving the speakers with more power than they can handle. Remember, most amplifiers put out their full-rated power well before the volume control is turned all the way up! If your speakers distort when you play them loud, turn down the amplifier or get a bigger one.

Using Your Speakers with Dolby Digital Systems with and without the Separate LFE Input

There are many options for hooking up your BP7000SC/BP7001SCs to a Dolby Digital and DTS 5.1 (6.1, 7.1) system. The basic hook-up of the speakers is the same as described in the preceding sections of this manual (Diagrams 1-2). The simplest way to use the speakers with Dolby Digital and DTS 5.1 (6.1, 7.1) would then be to hook up the speakers according to any one of these diagrams (Diagrams 1-2) and then use the “bass management system” built into your receiver or decoder to internally direct the LFE (.1 discrete bass) signal to the left and right channels where it would be fed to the subwoofer contained in each BP7000SC/BP7001SC loudspeaker. This can be accomplished through your Dolby Digital and DTS 5.1 (6.1, 7.1) decoding bass management system by “telling the electronics” (usually by using its on-screen display control feature) that you don’t have a subwoofer “No” and that you have “Large” left and right front speakers. Since the LFE .1 sub signal is then delivered to your subwoofers through the speaker wire, you will then get the full benefit of it as well as the bass information from the left and right channel as the advance circuitry within the speaker takes an infinitesimally small signal from the speaker wire and uses it to drive the built-in subwoofer amplifiers. If you have a Definitive center channel with a built-in powered subwoofer, you would normally tell the bass management system that you have a “Large” center channel. Otherwise, it would normally be set to “Small” center channel. However, in either case, you should experiment to see what sounds best in your particular system.

Alternatively, you can use the LFE/Sub Out jack on your electronics to feed the LFE input jacks on your BP7000SC/BP7001SCs. Simply use a Y connection coming out of the LFE output jack on your electronics to feed two line level cables, one connected to the LFE input on the right speaker and the other one connected to the LFE input on the left speaker. Use the bass management system on your decoder to “tell” your electronics that you have large left and right main speakers and subwoofer “Yes.”

When using the separate LFE inputs: If you have the speakers connected full range with all jumpers in, leave all the jumpers in. You can also use the separate LFE input in conjunction with bi-wiring the speakers as described on page 8.

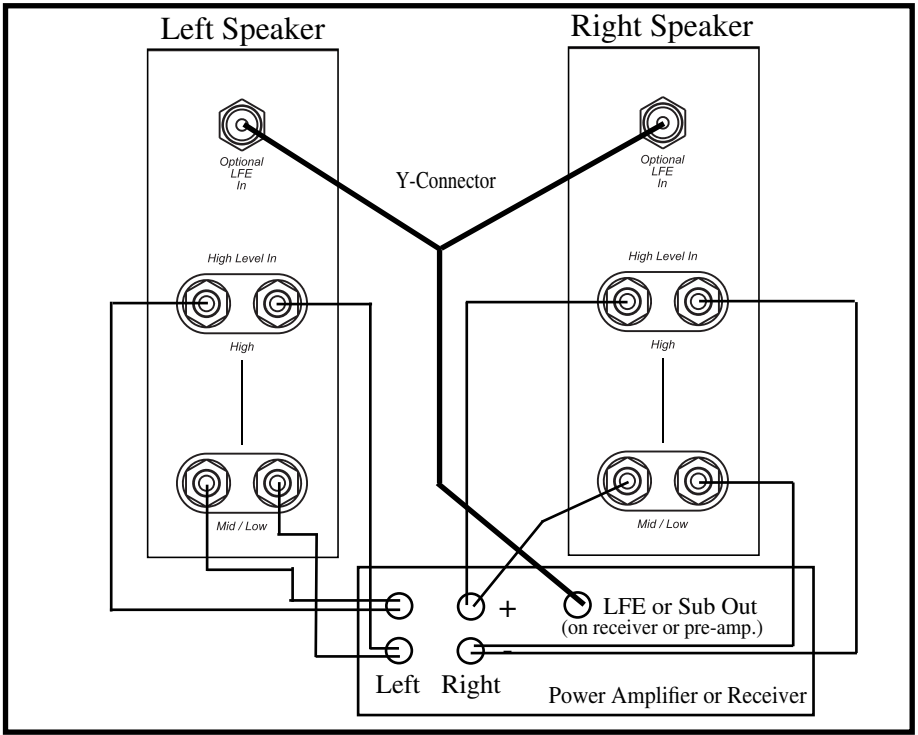

Diagram # 3: One Option for Using the BP7000sc/BP7001sc's Optional LFE Input (Bi-Wired)

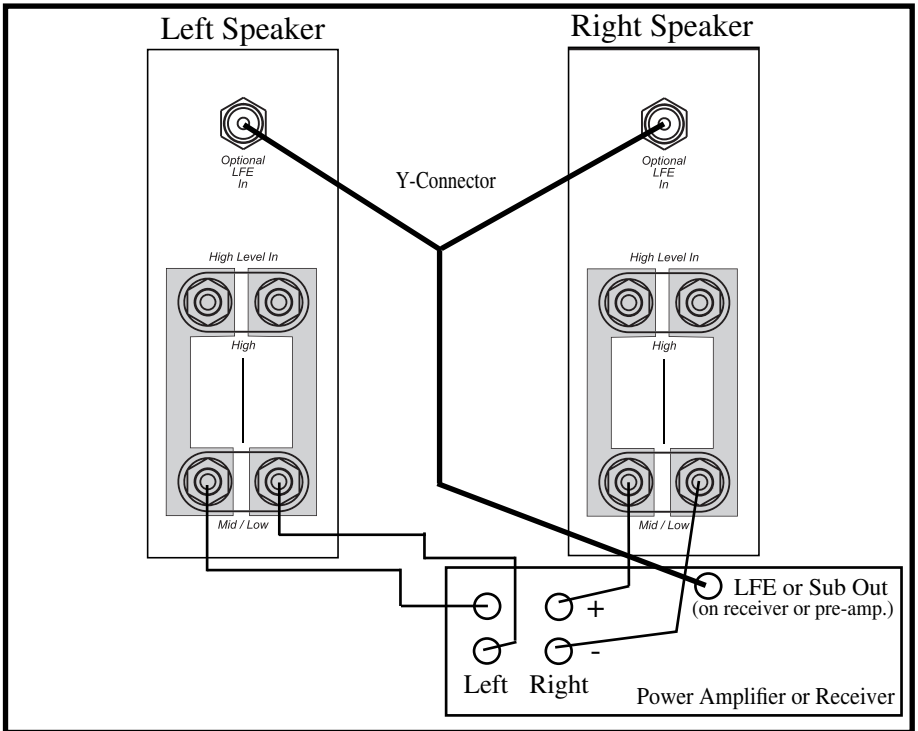

Diagram # 4: One Option for Using the BP7000sc/BP7001sc's Optional LFE Input (Non Bi-Wired)

Setting Bass and Treble Controls on Your Receiver or Amplifier

Normally we recommend that you set the “Bass” and “Treble” controls on flat or 0 dB. This will give you the most linear and natural sound. If you want more bass, raise the subwoofer’s “Level” control on your BP7000SC/ BP7001SC, keeping in mind that even a little turn of the knob can make a big difference in the sound. Also, if your amplifier or receiver has a graphic equalizer, we recommend that you leave it flat. The reason for this is that we have spoken with many consumers about what they thought were improperly sounding speakers when, in fact the problem was misadjusted tone controls. When in doubt, leave them flat; this almost always sounds the best.

Powering Up the Active Subwoofer Section

Your BP7000SC/BP7001SCs contain a built-in, active powered subwoofer section as well as an electronic crossover and so each BP7000SC/BP7001SC must be plugged into an electrical socket of the appropriate voltage (as indicated on the back of your unit) using the plug on the end of the black cord attached to the electronics module on the back of the loudspeaker. The BP7000SC/BP7001SC has a special circuit which automatically turns the powered subwoofer section on when a signal is fed to the loudspeaker and does not require an on-off switch. The red LED on the back panel will light up when a signal is sensed and the amplifier turns on. Please note that after the cessation of a signal, it may take up to an hour for the amplifier to actually turn off. In some instances, because of RF presence in your area, the red LEDs may not turn off. However, this is nothing to be concerned about as the amplifiers draw almost no power when they are idling.

To prevent accidental damage to the subwoofers built into your BP7000SC/ BP7001SCs from overdriving the system, the subwoofers feature an internal overload protection circuit, which will turn the subwoofers off or down when overdriven or overheated and will then resume normal operation after a few minutes.

Setting Your Speakers’ Low-Frequency Level Control

Your BP7000SC/BP7001SCs have a level control which allows you to perfectly tune the output level of the powered low frequency subwoofer section to match your room as well as to fulfill your own personal listening preferences. Please note that there are no controls to vary the crossover points or phase because these have been factory calibrated and set to provide perfect blending (a major performance benefit of this innovative product). **We suggest beginning with the level control set at approximately 12 o’clock.**

Setting Low-Frequency Balance When Using Separate LFE Input

We suggest that when you are using a separate LFE input, you set the bass level on your BP7000SC/BP7001SCs to sound balanced when listening to music in stereo and use the .1 channel or bass level control in your Dolby Digital channel balancing procedure on your decoder to raise or lower the bass level for movie sound effects as you require.

Normally the level control of the left speaker will be set the same as the level control of the right speaker. However, these controls can also be set differently on the two speakers in order to allow you to vary the response of left and right speakers separately to compensate for variations and asymmetrical positioning of the left and right speakers in your room (i.e., when one is closer to a side wall or corner, etc.) if this is how you must set them up. This is a very unique and useful feature which allows you much greater flexibility in loudspeaker placement, as well as the ability to optimize what could otherwise be difficult placement situations.

VERY IMPORTANT: Setting Channel Balance and Bass Management Systems

Dolby Digital and DTS 5.1 (6.1, 7.1) systems and decoders have a critical channel balancing procedure for the left and right front speakers, center channel, rears and subwoofer (if it is hooked up through the “LFE or Sub Out” low-level connection) which must be followed if the system is to perform properly. We have spoken with many system users with problems relating to the overall sound of their system which could be clearly traced back to improper system balance. In fact, many users never realize that there is a system balance procedure to be followed.

Also note that Dolby Digital and DTS 5.1 (6.1, 7.1) systems and decoders have bass management systems (systems which direct the bass to the various channels) which vary from unit to unit. This bass management system must also be properly adjusted. We have spoken with many system users with problems relating to the overall sound of their system which could be clearly traced back to improper bass management. In fact, many users never realize that there is a bass management procedure to be followed.

If your BP7000SC/BP7001SCs are hooked up with speaker level wires and no low-level LFE channel input, your receiver or decoder’s bass management system should be set for “Large” left and right main speakers and “No” subwoofer (even though you have subwoofers built into your BP7000SC/BP7001SCs). This will properly channel the sub bass LFE information into the left and right channels and then into your subwoofers built into your BP7000SC/BP7001SCs. If you have a Definitive center channel with a built-in powered subwoofer, set your decoder’s bass management center channel setting to “Large” (although you should experiment with this to see what sounds best in your specific system). If you are using large rear surround speakers with very extended low frequency response such as a large Definitive floor-standing system or one with a built-in powered subwoofer, set the rear channels of your decoder’s bass management system to “Large.” If not, set them to “Small.”

Troubleshooting

If you experience any difficulties with your BP7000SC/BP7001SCs, try the suggestions described below. If you are still having problems, please consult your Definitive Technology Authorized Dealer for assistance.

1. Make sure all your system interconnects and power cords are solidly in place.
2. Should you experience any level of ground hum or noise, try plugging the power cord into the same circuit as your amplifier.
3. The system is provided with sophisticated internal protection circuitry. If for some reason the protection circuitry is tripped, please turn down your system's volume and wait five minutes before trying the system again. If the amplifier should overheat, the system will turn off until the amplifier cools down and resets.
4. Check to be sure that your power cord has not been damaged.
5. Check that no foreign objects or liquid has entered the cabinet.
6. If you cannot get the subwoofer driver on the side of the speaker to turn on or if no sound comes out and you are sure the system is set up properly, please bring the loudspeaker to your Definitive Technology Authorized Dealer for assistance.
Call First.

Complete Home Theater Systems

We strongly suggest that you use matching Definitive center channel and rear/surround speakers to complete your Definitive home theater system. Please note that you can use Definitive Bipolar Power Towers as rear or side surround speakers with excellent results for both music and movies.

Service

Service and warranty work on your Definitive loudspeakers will normally be performed by your local Definitive Technology dealer. If, however, you wish to return the speaker to us, please contact us first, describing the problem and requesting authorization as well as the location of the nearest factory service center. **Please note that the address given in this booklet is the address of our offices only. Under no circumstances should loudspeakers be shipped to our offices or returned without contacting us first and obtaining return authorization.**

Definitive Technology Offices
11433 Cronridge Drive, Owings Mills, Maryland 21117
Phone: 410-363-7148

Visit us at www.definitivetech.com.

Technical Assistance

It is our pleasure to offer assistance if you have any questions regarding your BP7000sc/BP7001scs or their set-up. Please contact your nearest Definitive Technology dealer or contact us directly at 410-363-7148.

Specifications

BP7000sc

Dimensions:	8.9"W x 16.6"D x 52.5"H
Frequency Response:	11 Hz–30 kHz
Efficiency:	92 dB
Nominal Impedance:	Compatible with 8 ohms
Driver Complement:	Four 6.5" high definition cast-magnesium basket polymer upper bass/midrange drivers. Two 1" pure aluminum dome tweeters with silk surrounds. One 14" long-throw SuperCube® Technology subwoofer coupled to two 14" infrasonic radiators.

Recommended

Associated Amplification:	20–1000 watts/channel
Built-in Subwoofer	
Power Amplifier:	1800 watts Digitally-Coupled Class D amplifier
Finish:	Piano-gloss black lacquer or piano-gloss golden cherry finish
Fuse Size:	8-amp 250-volt slow-blow fuse for the 110-volt version and 4-amp 250-volt slow-blow fuse for the 240-volt version

BP7001sc

Dimensions:	8.4"W x 15"D x 48"H
Frequency Response:	13 Hz–30 kHz
Efficiency:	92 dB
Nominal Impedance:	Compatible with 8 ohms
Driver Complement:	Four 6.5" high definition cast-magnesium basket polymer upper bass/midrange drivers. Two 1" pure aluminum dome tweeters with silk surrounds. One 10" long-throw SuperCube® Technology subwoofer coupled to two 10" infrasonic radiators.

Recommended

Associated Amplification:	20–600 watts/channel
Built-in Subwoofer	
Power Amplifier:	1500 watts Digitally-Coupled Class D amplifier
Finish:	Piano-gloss black lacquer or piano-gloss golden cherry finish
Fuse Size:	8-amp 250-volt slow-blow fuse for the 110-volt version and 4-amp 250-volt slow-blow fuse for the 240-volt version

Limited Warranty: 5-Years for Drivers and Cabinets, 3-Years for Electronic Components

Definitive Technology warrants to the original retail purchaser only that this Definitive Technology Loudspeaker Product (the "Product") will be free from defects in materials and workmanship for a period of five (5) years covering the drivers and cabinets, and three (3) years for the electronic components from the date of the original purchase from a Definitive Technology Authorized Dealer. However, this warranty will automatically terminate prior to the expiration of five (5) years for the drivers and cabinets and three (3) years for the electronic components if the original retail purchaser sells or otherwise transfers the Product to any other party. The original retail purchaser shall hereinafter be referred to as "you." Defective Products must be shipped, together with proof of date of purchase, prepaid insured to the Authorized Dealer from whom you purchased the Product, or to the nearest factory service center. Product(s) must be shipped in the original shipping container or its equivalent; in any case the risk of loss or damage in transit is to be borne by you. If, upon examination at the Factory or a Definitive Technology Authorized Dealer, it is determined that the unit was defective in materials or workmanship at any time during this Warranty period, Definitive Technology or the Definitive Technology Authorized Dealer will, at its option, repair or replace this Product at no additional charge, except as set forth below. All replaced parts and Product(s) become the property of Definitive Technology. Product(s) replaced or repaired under this Warranty will be returned to you, within a reasonable time, freight collect.

This Warranty does not include service or parts to repair damage caused by accident, misuse, abuse, negligence, inadequate packing or shipping procedures, commercial use, voltage in excess of the rated maximum of the unit, cosmetic appearance of cabinetry not directly attributable to defects in materials or workmanship, or service, or repair or modification of the Product which has not been authorized by Definitive Technology. Definitive Technology makes no Warranty with respect to its Products purchased from dealers or outlets other than Definitive Technology Authorized Dealers. This Warranty is in lieu of all other expressed Warranties. If this Product is defective in material or workmanship as warranted above, your sole remedy shall be repair or replacement as provided above. In no event will Definitive Technology be liable to you for any incidental or consequential damages arising out of the use or inability to use the Product, even if Definitive Technology or a Definitive Technology Authorized Dealer has been advised of the possibility of such damages, or for any claim by any other party. Some states do not allow the exclusion or limitation of consequential damages, so the above limitation may not apply to you.

All implied warranties on the Product are limited to the duration of this expressed Warranty. Some states do not allow limitation on how long an implied Warranty lasts, so the above limitations may not apply to you. This Warranty gives you specific legal rights, and you also may have other rights which vary from state to state.



**This product complies with the essential
requirements of the EMC directive 89/336/EEC.**

Free Manuals Download Website

<http://myh66.com>

<http://usermanuals.us>

<http://www.somanuals.com>

<http://www.4manuals.cc>

<http://www.manual-lib.com>

<http://www.404manual.com>

<http://www.luxmanual.com>

<http://aubethermostatmanual.com>

Golf course search by state

<http://golfingnear.com>

Email search by domain

<http://emailbydomain.com>

Auto manuals search

<http://auto.somanuals.com>

TV manuals search

<http://tv.somanuals.com>