



#### ASIA

**Delta Electronics, Inc.**  
Taoyuan1  
31-1, Xingbang Road, Guishan Industrial Zone,  
Taoyuan County 33370, Taiwan, R.O.C.  
TEL: 886-3-362-6301 / FAX: 886-3-362-7267

**Delta Electronics (Jiang Su) Ltd.**  
Wujiang Plant3  
1688 Jiangxing East Road,  
Wujiang Economy Development Zone,  
Wujiang City, Jiang Su Province,  
People's Republic of China (Post code: 215200)  
TEL: 86-512-6340-3008 / FAX: 86-769-6340-7290

**Delta Electronics (Japan), Inc.**  
Tokyo Office  
Delta Shibadaimon Building, 2-1-14 Shibadaimon,  
Minato-Ku, Tokyo, 105-0012, Japan  
TEL: 81-3-5733-1111 / FAX: 81-3-5733-1211

**Delta Electronics (Korea), Inc.**  
Donghwa B/D 3F, 235-6, Nonhyun-dong,  
Kangnam-gu, Seoul 135-010, Korea  
TEL: 82-2-515-5303/5 / FAX: 82-2-515-5302

**Delta Electronics (Singapore) Pte. Ltd.**  
8 Kaki Bukit Road 2, #04-18 Ruby Warehouse Complex,  
Singapore 417841  
TEL: 65-6747-5155 / FAX: 65-6744-9228

#### AMERICA

**Delta Products Corporation (USA)**  
Raleigh Office  
P.O. Box 12173, 5101 Davis Drive,  
Research Triangle Park, NC 27709, U.S.A.  
TEL: 1-919-767-3813 / FAX: 1-919-767-3939

#### EUROPE

**Deltronics (The Netherlands) B.V.**  
Eindhoven Office  
De Witbogt 15, 5652 AG Eindhoven, The Netherlands  
TEL: 31-40-2592850 / FAX: 31-40-2592851

\*We reserve the right to change the information in this manual without prior notice

20080122



## DOP Series HMI Connection Manual



# DOP Series HMI Connection Manual



[www.delta.com.tw/industrialautomation](http://www.delta.com.tw/industrialautomation)

## 1.1 Pin Definition of Serial Communication

### ■ DOP-A Series

#### COM1

PIN	Mode
	RS-232
1	N.C
2	RXD
3	TXD
4	N.C
5	GND
6	N.C
7	RTS
8	CTS
9	N.C

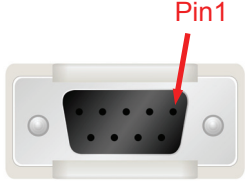

#### COM2

PIN	Mode 1	Mode 2	Mode 3
	RS-232	RS-422	RS-485
1	N.C	RXD-	D-
2	RXD	RXD+	D+
3	TXD	TXD+	D+
4	N.C	TXD-	D-
5	GND	GND	GND
6	N.C	RTS-	N.C
7	RTS	RTS+	N.C
8	CTS	CTS+	N.C
9	N.C	CTS-	N.C

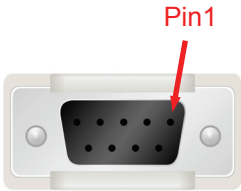

### NOTE

- 1) Mode 3 is for RS-485. Pin 2 & 3 are D+ and pin 1 & 4 are D-.
- 2) Grounding is highly recommended if RS-485 & RS-422 are used for long transmission.
- 3) DO NOT connect Frame Ground (FGND) to GND. Please connect FGND to the outer covering of connector.
- 4) Transmission speed is relevant to distance and baud rate.

■ DOP-AE Series

COM1

	PIN	Mode
		RS-232
	1	N.C
	2	RXD
	3	TXD
	4	N.C
	5	GND
	6	N.C
	7	RTS
	8	CTS
9	N.C	

COM2/COM3

		PIN	Mode 1	Mode 2	Mode 3	Mode 4	Mode 5	Mode 6
		RS-232	RS-422	RS-485	RS-232x2	RS-422x2	RS-485x2	
	COM2	1	N.C	RXD-	D-	N.C	RXD-	D-
		2	RXD	RXD+	D+	RXD	RXD+	D+
		3	TXD	TXD+	D+	TXD	TXD+	D+
		4	N.C	TXD-	D-	N.C	TXD-	D-
	COM3	5	GND	GND	GND	GND	GND	GND
		6	N.C	RTS-	N.C	N.C	TXD-	D-
		7	RTS	RTS+	N.C	TXD	TXD+	D+
		8	CTS	CTS+	N.C	RXD	RXD+	D+
9		N.C	CTS-	N.C	N.C	RXD-	D-	

■ DOP AS Series

COM1/COM3

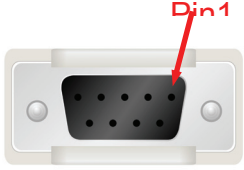
		<b>PIN</b>	<b>Mode 1</b>	<b>Mode 2</b>
			<i>RS-232</i>	<i>RS-232x2</i>
	<b>COM 1</b>	1	N.C	N.C
		2	RXD	RXD
		3	TXD	TXD
		4	N.C	N.C
	<b>COM 3</b>	5	GND	GND
		6	N.C	N.C
		7	RTS	TXD
		8	CTS	RXD
9		N.C	N.C	

COM2

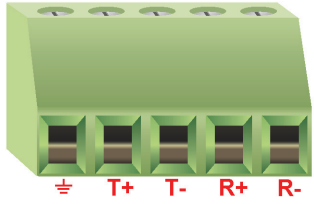
	<b>PIN</b>	<b>Mode 1</b>	<b>Mode 2</b>
		<i>RS-422</i>	<i>RS-485</i>
	R-	RXD-	D-
	R+	RXD+	D+
	T-	TXD-	D-
	T+	TXD+	D+
		GND	GND

## 1.2 Cable for Download

### ■ Download via COM Port

#### RS-232

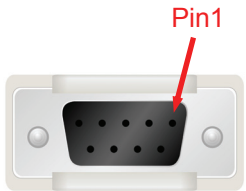
DOP series HMI 9 pin D-SUB male (RS-232)	PC 9 pin D-SUB female (RS-232)	Controller
RXD (2)	(3) TXD	
TXD (3)	(2) RXD	
GND (5)	(5) GND	
RTS (7)	(8) CTS	
CTS (8)	(7) RTS	

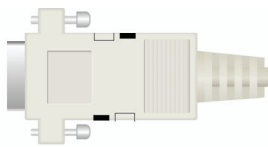

D-SUB 9pin to DOP series (male)

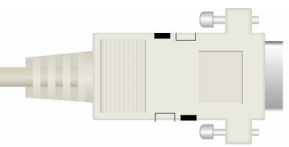

D-SUB 9pin to PC (female)

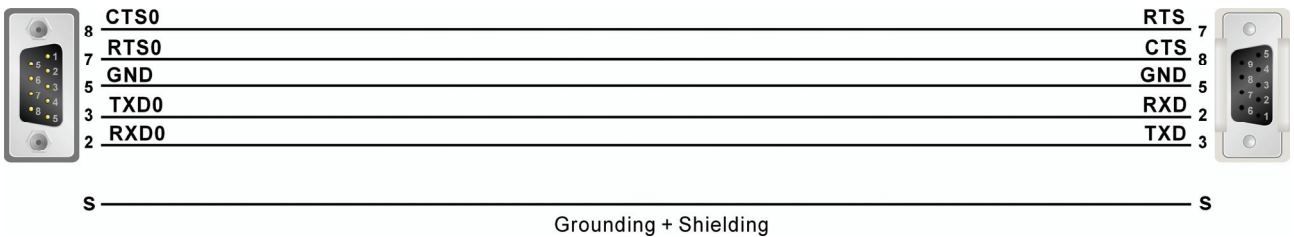

### ■ Download via USB Flash Drive

#### USB Connection



USB TAPE B to DOP series



USB TAPE A to PC

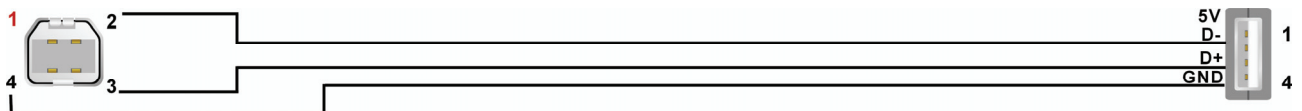

### 1.3 Supported Controllers and Devices

Please refer to the following table for supported controllers and devices provided by DOP series HMI.

Brand	Controller Name / Series Name
Delta	<u>Delta Controller</u> For Servo/AC drive/Temperature Controller/PLC (984 RTU mode / ASCII mode)
	<u>Delta DVP PLC</u>
Allen Bradley	<u>MicroLogix PLC</u>
	<u>SLC5 PLC</u>
Cimon	<u>Loader Protocol</u>
Copley	<u>Servo (Stepnet Protocol)</u>
Danfoss	<u>VLT 2800 (FC Protocol)</u>
Emerson	<u>EC20 Series PLC</u>
Facon	<u>FB Series PLC</u>
Festo	<u>Festo PLC</u>
GE Fanuc	<u>90 Series SNP PLC</u>
Hitachi	<u>EH Series</u>
Hust	<u>Hust CNC Controller</u>
Jetter	<u>Nano Series PLC</u>
	<u>JC Series PLC</u>
Keyence	<u>KV/KZ Series</u>
Koyo	<u>SU/DL Series</u>
	<u>K-Sequence</u>
Lenze	<u>LECOM-A/B Protocol</u>
LG	<u>Master-K120S/200S</u>
	<u>Glofa GM6 CNET</u>
	<u>Master-K CNET</u>
	<u>XGT CNET</u>
LI YAN	<u>LYPLC EX</u>
M2i	<u>M2i Master</u>
	<u>M2i Slave</u>
Matsushita	<u>FP Series</u>
Mirle	<u>FAMA SC</u>

Brand	Controller Name / Series Name	
Mitsubishi	<u>FX / FX2N</u>	
	<u>FX3U</u>	
	<u>A Series/J71UC24</u>	
	<u>Mitsubishi A2A/A2AS/A2USH A1SH/A3N/A2ASH CPU Port</u>	
	<u>Q Series CPU Port</u>	
	<u>Q Series Computer Link</u>	
	<u>FX Series Computer Link</u>	
	<u>J2s Series</u>	
MKS	<u>BY125</u>	
	<u>CT150</u>	
	<u>MC700/720</u>	
Modbus	<u>Modbus (Master) --- 984 RTU / ASCII mode</u>	
	<u>Hexadecimal Address (Master) --- RTU / ASCII mode</u>	
	<u>nW (Master) --- RTU / ASCII mode</u>	
	<u>Modbus (Slave) --- RTU / ASCII mode</u>	
Modicon	TSX Micro	<u>Uni-Telway</u>
		<u>Modbus RTU</u>
	<u>TWIDO</u>	
Moeller	<u>Moeller PLC</u>	
NIKKI DENSO	<u>NCS-FI/FS Series</u>	
Omron	<u>C Series</u>	
	<u>CJ1/CS1 Series</u>	
	<u>TPM1A</u>	
Siemens	<u>S7 200</u>	
	<u>S7-300 (with PC Adaptor)</u>	
	<u>S7-300 (without PC Adaptor)</u>	
Taian	<u>TP02 PLC</u>	
Vigor	<u>M Series</u>	
VIPA	<u>VIPA PLC</u>	
Yokogawa	<u>ACE PLC</u>	

## Delta (Servo/AC Drive/PLC/Temperature) Controller

[Back to Table](#)

## A. HMI factory setting

Baud rate: ASCII: 9600, 7, None, 2.

RTU: 9600, 8, None, 2.

Controller station number: 1.

Control area/status area: None.



- 1) This driver can support all Delta products, i.e. AC drive, PLC, Servo, Temperature Controller and Modbus standard connection. The users can easily set and communicate with these devices via using this driver.
- 2) For people who are using Modbus standard connection:  
 Modbus / ASCII (Master), Modbus / 984 RTU (Master), Modbus / ASCII Hex Address (Master) and Modbus / RTU Hex Address (Master) can be compatible with the new Delta controller ASCII and Delta controller RTU. To change the driver settings, the user only needs to change the “Controller” Option which is used to set the controller, then the new driver can be used immediately.

## B. Definition of controller Read/Write address

## Registers

Register Type	Format	Read/Write Range		Data Length
		Word No.	Bit No.	
Servo communication address	SERVO-n	n: 0 ~ 0700h	N/A	Word
AC drive communication address	INVERTER-n	n: 0 ~ 2299h	N/A	Word
TCntrl communication address	TEMP_CTRL-n	n: 0 ~ 6000h	N/A	Word
WORD_DEVICE_X	PLC_Xn	n: 0 ~ 360(octal)	N/A	Word
WORD_DEVICE_Y	PLC_Yn	n: 0 ~ 360(octal)	N/A	Word
WORD_DEVICE_M	PLC_Mn	n: 0 ~ 1520, 1536 ~ 4080	N/A N/A	Word Word
WORD_DEVICE_S	PLC_Sn	n: 0 ~ 1008	N/A	Word
WORD_DEVICE_T	PLC_Tn	n: 0 ~ 255	N/A	Word
WORD_DEVICE_C	PLC_Cn	n: 0 ~ 199	N/A	Word
WORD_DEVICE_D	PLC_Dn	n: 0 ~ 4095, 4096 ~ 9999	N/A N/A	Word Word
WORD_DEVICE_HC	PLC_HCn	n: 200 ~ 255	N/A	Double Word
PLC communication address Module	PLC_Modulen	n: 4000 ~ 4499h	N/A	Word



Register Type	Format	Read/Write Range		Data Length
		Word No.	Bit No.	
Output Registers	RW-n	n: 0 ~ FFFFh	N/A	Word
Input Registers	R-n	n: 0 ~ FFFFh	N/A	Word
Output Registers	Wn	n: 40001 ~ 50000	N/A	Word
Input Registers	Wn	n: 30001 ~ 40000	N/A	Word

 **NOTE**

- 1) The above addresses of Servo, AC drive, Temperature controller and PLC Module are in hexadecimal format. PLC Word Device X and Y are in octal format. Other PLC Word Device M, S, T, C, D and HC are in decimal format.
- 2) WORD\_DEVICE\_X / WORD\_DEVICE\_Y / WORD\_DEVICE\_M / WORD\_DEVICE\_S: Address must be 0 or the multiple of 16.

**Contacts**

Contact type	Format	Read/Write Range	
		Word No.	Bit No.
Servo communication address	SERVO-n.b	n: 0 ~ 0700h	b: 0 ~ f
AC drive communication address	INVERTER-n.b	n: 0 ~ 2299h	b: 0 ~ f
TCntrl communication address	TEMP_CTRL-n.b	n: 0 ~ 6000h	b: 0 ~ f
Servo Digital Input	SERVO_DI-n	N/A	n: 1 ~ 8
Servo Digital Output	SERVO_DO-n	N/A	n: 1 ~ 5
WORD_DEVICE_X	PLC_Xn	N/A	n: 0 ~ 377(octal)
WORD_DEVICE_Y	PLC_Yn	N/A	n: 0 ~ 377(octal)
WORD_DEVICE_M	PLC_Mn	N/A	n: 0 ~ 1535 1536 ~ 4095
WORD_DEVICE_S	PLC_Sn	N/A	n: 0 ~ 1023
WORD_DEVICE_T	PLC_Tn	N/A	n: 0 ~ 255
WORD_DEVICE_C	PLC_Cn	N/A	n: 0 ~ 255
TCntrl Bit communication address	TEMP_CTRLB-n	N/A	n: 800 ~ 8FFh
Discrete Outputs	RWB-n	N/A	n: 0 ~ FFFFh
Discrete Inputs	RB-n	N/A	n: 0 ~ FFFFh
Discrete Outputs	Bn	N/A	n: 1 ~ 10000
Discrete Inputs	Bn	N/A	n: 10001 ~ 20000

 **NOTE**

- 1) The above addresses of Servo, AC drive, Temperature controller and PLC Module are in hexadecimal format.

- 2) PLC Word Device X and Y are in octal format. Other PLC Word Device M, S, T, C, D and HC are in decimal format.
- 3) Servo Digital Input and Servo Digital Output are only for Servo.

**Pay close attention to the following important notes:**

- 4) For Delta AC drive:

Communication address for HMI read/write address uses hexadecimal format. For detailed information about communication address of Delta AC drive, please refer to Delta AC drive “User Manual”.

Example 1: Parameter 9-01 of Delta VFD-S drive Transmission Speed needs to be set to INVERTER901 in HMI. (Decimal 9 is converted to 09 in hexadecimal and 01 is converted to 01 in hexadecimal).

Therefore, setting INVERTER901 to HMI will discard the first 0)

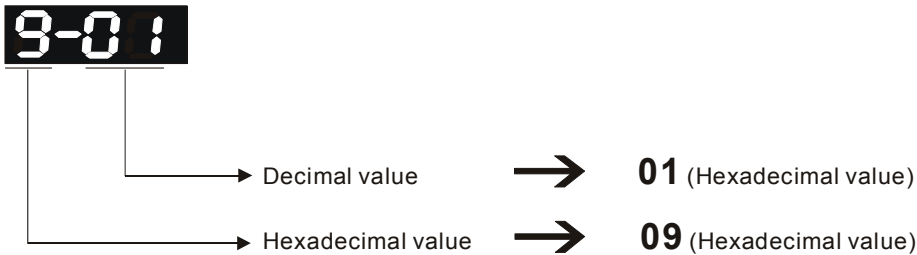

The communication address of parameter 9-01 is 0901H.

Example 2: if setting of parameter 8-17 (Lower Bound of DC Braking Start-up Frequency) of Delta VFD-S drive is desired, user needs to set INVERTER811 in HMI. (8 is converted to 08 in hexadecimal and 17 is converted to 11 in hexadecimal. Therefore, setting the INVERTER811 to HMI will discard the first 0)

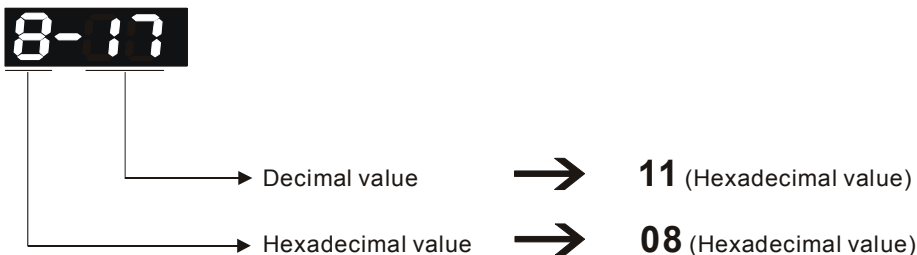

The communication address of parameter 8-17 is 0811H.

- 5) For Delta Servo drive:

- HMI Read/Write address setting needs to input the communication address listed in SERVO “User Manual”.
- Servo Digital Input and Servo Digital Output are only for Servo.

- 6) For Delta Temperature Controller (DTA series):

HMI can be set up to connect to several Delta A series temperature controllers on standard Modbus networks by using RTU transmission mode. However, the communication delay time may need to increase. Therefore, 5ms or longer is highly recommended.

C. Connections (Connector Pinouts)

Delta Servo

**RS-232**

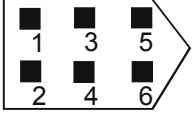
DOP Series 9 pin D-SUB male (RS-232)	Controller CN3 cable connector (RS-232)	Controller CN3 cable connector (RS-232)
RXD (2) ————— (2) TX TXD (3) ————— (4) RX GND (5) ————— (1) GND		 Top View

**RS-422**

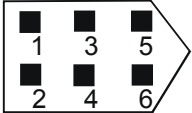
DOP Series 9 pin D-SUB male (RS-422)	Controller CN3 cable connector (RS-422)	Controller CN3 cable connector (RS-422)
RXD+ (2) ————— (5) TX+ RXD- (1) ————— (6) TX- TXD+ (3) ————— (3) RX+ TXD- (4) ————— (4) RX-		 Top View

**RS-485**

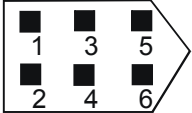
DOP Series 9 pin D-SUB male (RS-485)	Controller CN3 cable connector (RS-485)	Controller CN3 cable connector (RS-485)
RXD+ (2) ————┐ TXD+ (3) ————┘ ————┐ ┌—————┐ (3) 485+ └—————┘ (5) 485+ RXD- (1) ————┐ TXD- (4) ————┘ ————┐ ┌—————┐ (4) 485- └—————┘ (6) 485-		 Top View

Delta AC drive

**RS-485**

DOP Series 9 pin D-SUB male (RS-485)	Controller RJ-11 cable connector (RS-485)	Controller RJ-11 cable connector (RS-485)
<pre>                     RXD+ (2) ---                      TXD+ (3) ---                      RXD- (1) ---                      TXD- (4) ---                      GND (5)  -----                                  (4) SG+                                 (3) SG-                                 (2) GND                     </pre>	 <p>2: GND 3: SG- 4: SG+</p> <p>1 → 6 Top View</p> <p>DO NOT use Pin 1, 5 and 6 while using RS-485 communication.</p>	

 **NOTE**

- 1) When connecting to a Delta VFD-M series AC drive, please connect Pin 5 (GND) of the Delta HMI and Pin 2 (GND) of the Delta VFD-M AC drive.

Temperature Controller

**RS-485**

DOP Series 9 pin D-SUB male (RS-485)	Controller RS-485 cable connector
<pre>                     RXD+ (2) ---                      TXD+ (3) ---                      RXD- (1) ---                      TXD- (4) ---                                  D+                                 D-                     </pre>	

## Delta DVP PLC

[Back to Table](#)

## A. HMI factory settings

Baud rate: 9600, 7, Even, 1.

Controller station number: 1.

Control area/status area: D0 / D10.

## B. Definition of controller Read/Write address

## Registers

Register Type	Format	Read/Write Range	
		<u>Word No.</u>	<u>Bit No.</u>
X_Data	Xn	n: 0 ~ 360(octal)	N/A
Y_Data	Yn	n: 0 ~ 360(octal)	N/A
M_Data	Mn	n: 0 ~ 1520, 1536 ~ 4080	N/A
S_Data	Sn	n: 0 ~ 1008	N/A
T_Register	Tn	n: 0 ~ 255	N/A
C_Register	Cn	n: 0 ~ 199	N/A
D_Register	Dn	n: 0 ~ 4095, 4096 ~ 9999	N/A
HC_Register	Cn	n: 200 ~ 255	N/A

 **NOTE**

- 1) (W) is "Word".
- 2) (DW) is "Double Word".
- 3) X\_Data / Y\_Data / M\_Data / S\_Data: Address must be 0 or the multiple of 16.

## Contacts

Contact type	Format	Read/Write Range	
		<u>Word No.</u>	<u>Bit No.</u>
X_Data	Xn	N/A	n: 0 ~ 377(octal)
Y_Data	Yn	N/A	n: 0 ~ 377(octal)
M_Data	Mn	N/A	n: 0 ~ 1520, 1536 ~ 4080
S_Data	Sn	N/A	n: 0 ~ 1023
T_Coil	Tn	N/A	n: 0 ~ 255
C_Coil	Cn	N/A	n: 0 ~ 255

**C. Connections (Connector Pinouts)**

**RS-232 Connection**

DOP Series 9 pin D-SUB male (RS-232)	Controller 8 pin Mini DIN male (RS-232)	Controller 8 pin Mini DIN male (RS-232)
<p>RXD (2) ————— (5) TXD</p> <p>TXD (3) ————— (4) RXD</p> <p>GND (5) ————— (8) GND</p>		 <p>Top View</p>

**RS-485 Connection**

DOP Series 9 pin D-SUB male (RS-485)	Controller RS-485 cable connector
<p>RXD+ (2) ————</p> <p>TXD+ (3) ————</p> <p>RXD- (1) ————</p> <p>TXD- (4) ————</p>	<p>D +</p> <p>D -</p>

## AllenBradley MicroLogix PLC

[Back to Table](#)

## A. HMI factory setting

Baud rate: 19200, 8, None, 1.

PLC station number: 1.

Control area/status area: B3:0/B3:10.

## B. Definition of controller Read/Write address

## Registers

Register Type	Format	Read/Write Range		
		Word No.	Bit No.	
			Low Byte	High Byte File No.
Output File	O:n	n: 0 ~ 3	N/A	0
Input File	I:n	n: 0 ~ 3	N/A	1
Status File	S2:n	n: 0 ~ 65	N/A	2
Bit File	B3:n	n: 0 ~ 255	N/A	3
Timer Flag	T4:n	n: 0 ~ 255	N/A	4
Timer Preset Value	T4:n.PRE	n: 0 ~ 255	N/A	4
Timer Accumulator Value	T4:n.ACC	n: 0 ~ 255	N/A	4
Counter Flag	C5:n	n: 0 ~ 255	N/A	5
Counter Preset Value	C5:n.PRE	n: 0 ~ 255	N/A	5
Counter Accumulator Value	C5:n.ACC	n: 0 ~ 255	N/A	5
Control File	R6:n	n: 0 ~ 255	N/A	6
Control Size of Bit Array	R6:n.LEN	n: 0 ~ 255	N/A	6
Control Reserved File	R6:n.POS	n: 0 ~ 255	N/A	6
Integer File	N7:n	n: 0 ~ 255	N/A	7

- Bit No : Low byte is not used, so the value is 0. High byte stores file number.
- Data Size : Word.
- T4, C5 and R6 only read 1 Word once.
- If reading multiple Words once, the communication speed of PLC will be slow.

 **NOTE**

- 1) After last communication data has been memorized by PLC (PLC will send 0x10 0x05 consecutively), communication may fail. At this time, power off and power up HMI or power off and power up PLC once.

## Contacts

Contact Type	Format	Read/Write Range		
		<u>Word No.</u>	<u>Bit No.</u>	
			Low Byte	High Byte
			Bits	File No.
Output	O:n/b	n: 0 ~ 3	b: 0 ~ 15	0
Input	I:n/b	n: 0 ~ 3	b: 0 ~ 15	1
Status	S2:n/b	n: 0 ~ 65	b: 0 ~ 15	2
Bit	B3:n/b	n: 0 ~ 255	b: 0 ~ 15	3
Timer	T4:n/b	n: 0 ~ 255	b: 0 ~ 15	4
	T4:n/EN	n: 0 ~ 255	15	
	T4:n/TT	n: 0 ~ 255	14	
	T4:n/DN	n: 0 ~ 255	13	
Timer Preset Value	T4:n.PRE/b	n: 0 ~ 255	b: 0 ~ 15	4
Timer Accumulator Value	T4:n.ACC/b	n: 0 ~ 255	b: 0 ~ 15	4
Counter flag	C5:n/b	n: 0 ~ 255	b: 0 ~ 15	5
	C5:n/CU	n: 0 ~ 255	15	
	C5:n/CD	n: 0 ~ 255	14	
	C5:n/DN	n: 0 ~ 255	13	
	C5:n/OV	n: 0 ~ 255	12	
	C5:n/UN	n: 0 ~ 255	11	
	C5:n/UA	n: 0 ~ 255	10	
Counter Preset Value	C5:n.PRE/b	n: 0 ~ 255	b: 0 ~ 15	5
Counter Accumulator Value	C5:n.ACC/b	n: 0 ~ 255	b: 0 ~ 15	5
Control	R6:n/b	n: 0 ~ 255	b: 0 ~ 15	6
	R6:n/EN	n: 0 ~ 255	15	
	R6:n/DN	n: 0 ~ 255	13	
	R6:n/ER	n: 0 ~ 255	11	
	R6:n/UL	n: 0 ~ 255	10	
	R6:n/IN	n: 0 ~ 255	9	
	R6:n/FD	n: 0 ~ 255	8	
Control Size of Bit Array	R6:n.LEN/b	n: 0 ~ 255	b: 0 ~ 15	6
Control Reserved	R6:n.POS/b	n: 0 ~ 255	b: 0 ~ 15	6
Integer	N7:n/b	n: 0 ~ 255	b: 0 ~ 15	7

➤ Bit No. : Low byte stores Bit address. High byte stores file number.



C. Connections (Connector Pinouts)

**RS-232 Connection**

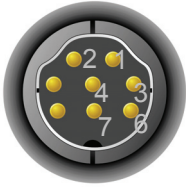
DOP Series 9 pin D-SUB male (RS-232)	Controller 8 pin Mini DIN male (RS-232)	Controller 8 pin Mini DIN male (RS-232)
<p>RXD (2) ————— (7) TXD</p> <p>TXD (3) ————— (4) RXD</p> <p>GND (5) ————— (2) GND</p> <p>                                  (3) RTS</p> <p>                                  (6) CTS</p>		 <p>Top View</p>

## AllenBradley SLC5 PLC

[Back to Table](#)

## A. HMI factory setting

Baud rate: 19200, 8, None, 1.

PLC station number: 1.

Control area/status area: B3:0/B3:10.



1) Error Check uses CRC (Cyclical Redundancy Check).

## B. Definition of controller Read/Write address

## Registers

Register Type	Format	Read/Write Range		
		<u>Word No.</u>	<u>Bit No.</u>	
		Element No.	Low Byte	High Byte
			Slot or File No.	
Output File	O:n O:s.n	n: 0 ~ 30	N/A	Slot No. s = 0 s: 0 ~ 255 File No. = 0
Input File	I:n I:s.n	n: 0 ~ 30	N/A	Slot No. s = 0 s: 0 ~ 255 File No. = 1
Status File	S2:n	n: 0 ~ 255	N/A	File No. = 2
Bit File	Bf:n	n: 0 ~ 255	N/A	f: 10 ~ 255 If f is ignored, file no. will be default setting 3.
Timer Flag	Tf:n	n: 0 ~ 255	N/A	f: 10 ~ 255 If f is ignored, file no. will be default setting 4.
Timer Preset Value	Tf:n.PRE	n: 0 ~ 255	N/A	f: 10 ~ 255 If f is ignored, file no. will be default setting 4.
Timer Accumulator Value	Tf:n.ACC	n: 0 ~ 255	N/A	f: 10 ~ 255 If f is ignored, file no. will be default setting 4.
Counter Flag	Cf:n	n: 0 ~ 255	N/A	f: 10 ~ 255 If f is ignored, file no. will be default setting 5.
Counter Preset Value	Cf:n.PRE	n: 0 ~ 255	N/A	f: 10 ~ 255 If f is ignored, file no. will be default setting 5.

Register Type	Format	Read/Write Range		
		Word No.	Bit No.	
		Element No.	Low Byte	High Byte
			Slot or File No.	
Counter Accumulator Value	Cf:n.ACC	n: 0 ~ 255	N/A	f: 10 ~ 255 If f is ignored, file no. will be default setting 5.
Control File	Rf:n	n: 0 ~ 255	N/A	f: 10 ~ 255 If f is ignored, file no. will be default setting 6.
Control Size of Bit Array	Rf:n.LEN	n: 0 ~ 255	N/A	f: 10 ~ 255 If f is ignored, file no. will be default setting 6.
Control Reserved File	Rf:n.POS	n: 0 ~ 255	N/A	f: 10 ~ 255 If f is ignored, file no. will be default setting 6.
Integer File	Nf:n	n: 0 ~ 255	N/A	f: 10 ~ 255 If f is ignored, file no. will be default setting 7.

➤ **Bit No** : Low byte is not used, so the value is 0. High byte stores file number.

**Contacts**

Contact Type	Format	Read/Write Range		
		Word No.	Bit No.	
		Element No.	Low Byte	High Byte
			Bits	Slot or File No.
Output	O:n/b O:s.n/b	n: 0 ~ 30	b: 0 ~ 15	Slot No. s = 0 s: 0 ~ 255 File No. = 0
Input	I:n/b I:s.n/b	n: 0 ~ 30	b: 0 ~ 15	Slot No. s = 0 s: 0 ~ 255 File No. = 1
Status	S2:n/b	n: 0 ~ 31	b: 0 ~ 15	2
Bit	Bf:n/b	n: 0 ~ 255	b: 0 ~ 15	f: 10 ~ 255 If f is ignored, file no. will be default setting 3.
Timer	Tf:n/b Tf:n/EN Tf:n/TT Tf:n/DN	n: 0 ~ 255 n: 0 ~ 255 n: 0 ~ 255 n: 0 ~ 255	b: 0 ~ 15 15 14 13	f: 10 ~ 255 If f is ignored, file no. will be default setting 4.
Timer Preset Value	Tf:n.PRE/b	n: 0 ~ 255	b: 0 ~ 15	f: 10 ~ 255 If f is ignored, file no. will be default setting 4.

Contact Type	Format	Read/Write Range		
		Word No.	Bit No.	
		Element No.	Low Byte	High Byte
			Bits	Slot or File No.
Timer Accumulator Value	Tf:n.ACC/b	n: 0 ~ 255	b: 0 ~ 15	f: 10 ~ 255 If f is ignored, file no. will be default setting 4.
Counter Flag	Cf:n/b	n: 0 ~ 255	b: 0 ~ 15	f: 10 ~ 255 If f is ignored, file no. will be default setting 5.
	Cf:n/CU	n: 0 ~ 255	15	
	Cf:n/CD	n: 0 ~ 255	14	
	Cf:n/DN	n: 0 ~ 255	13	
	Cf:n/OV	n: 0 ~ 255	12	
	Cf:n/UN	n: 0 ~ 255	11	
	Cf:n/UA	n: 0 ~ 255	10	
Counter Preset Value	Cf:n.PRE/b	n: 0 ~ 255	b: 0 ~ 15	f: 10 ~ 255 If f is ignored, file no. will be default setting 5.
Counter Accumulator Value	Cf:n.ACC/b	n: 0 ~ 255	b: 0 ~ 15	f: 10 ~ 255 If f is ignored, file no. will be default setting 5.
Control	Rf:n/b	n: 0 ~ 255	b: 0 ~ 15	f: 10 ~ 255 If f is ignored, file no. will be default setting 6.
	Rf:n/EN	n: 0 ~ 255	15	
	Rf:n/DN	n: 0 ~ 255	13	
	Rf:n/ER	n: 0 ~ 255	11	
	Rf:n/UL	n: 0 ~ 255	10	
	Rf:n/IN	n: 0 ~ 255	9	
	Rf:n/FD	n: 0 ~ 255	8	
Control Size of Bit Array	Rf:n.LEN/b	n: 0 ~ 255	b: 0 ~ 15	f: 10 ~ 255 If f is ignored, file no. will be default setting 6.
Control Reserved	Rf:n.POS/b	n: 0 ~ 255	b: 0 ~ 15	f: 10 ~ 255 If f is ignored, file no. will be default setting 6.
Integer	Nf:n/b	n: 0 ~ 255	b: 0 ~ 15	f: 10 ~ 255 If f is ignored, file no. will be default setting 7.

➤ **Bit No** : Low byte stores Bit address. High byte stores file number.

 **NOTE**

1) Device O and I need to assign Slot No. (s). If not assign Slot No., it will use default setting 0.

C. Connections (Connector Pinouts)

**RS-232**

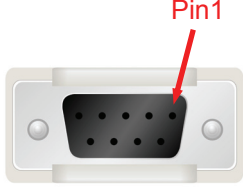
DOP series 9 pin D-SUB male (RS-232)	Controller 9 pin D-SUB female (RS-232)	Controller 9 pin D-SUB female (RS-232)
	<p>RXD (2) ————— (3) TXD</p> <p>TXD (3) ————— (2) RXD</p> <p>GND (5) ————— (5) SG</p> <p>                              └ (7) RTS</p> <p>                                  └ (8) CTS</p>	 <p>Pin1</p> <p>Top View</p>

## Cimon PLC (Loader Protocol)

[Back to Table](#)**A. HMI factory setting**

Baud rate: 38400, 8, None, 1, RS-232.

PLC station number: 1.

Control area/status area: D00000 / D00010.

**B. Definition of controller Read/Write address****Registers**

Register Type	Format	Read/Write Range		Data Length
		<u>Word No.</u>	<u>Bit No.</u>	
Input	Xn	n: 000-512	N/A	Word
Output	Yn	n: 000-512	N/A	Word
General Purpose Relay	Mn	n: 000-999	N/A	Word
General Purpose Relay	Ln	n: 000-999	N/A	Word
Latch Relay	Kn	n: 000-999	N/A	Word
Flags	Fn	n: 000-127	N/A	Word
Timer (Set)	TSn	n: 0000-4095	N/A	Word
Timer (Current)	TCn	n: 0000-4095	N/A	Word
Counter (Set)	CSn	n: 0000-4095	N/A	Word
Counter (Current)	CCn	n: 0000-4095	N/A	Word
General Purpose Word Data	Dn	n:00000-31999	N/A	Word
Step Controller	Sn	n: 0-99	N/A	Byte

**Contacts**

Contact Type	Format	Read/Write Range	
		<u>Word No.</u>	<u>Bit No.</u>
Input	Xnb	n: 000-512	b: 0-F
Output	Ynb	n: 000-512	b: 0-F
General Purpose Relay	Mnb	n: 000-999	b: 0-F
General Purpose Relay	Ln timer	n: 000-999	b: 0-F
Latch Relay	Kn timer	n: 000-999	b: 0-F
Flags	Fnb	n: 000-127	b: 0-F
Timer Status	Tb	N/A	b: 0-4095
Counter Status	Cb	N/A	b: 0-4095

C. Connections (Connector Pinouts)

**RS-232**

DOP series 9 pin D-SUB male (RS-232)	Controller 6 pin RJ11	Controller 9 pin D-SUB female (RS-232)
RXD (2) ————— 2		 1 ~ 6 Top View
TXD (3) ————— 3		
GND (5) ————— 5		

 **NOTE**

1) Device S

The unit of PLC internal memory is byte and Device S is read by the unit of byte. Therefore, we recommend the user do not use two consecutive devices S as the read addresses or the interference will occur. For example, when choosing two numeric input device, please use S24 and S26, do not use S24 and S25.

## Copley Servo (Stepnet Protocol)

[Back to Table](#)**A. HMI factory setting**

Baud rate: 9600, 8, None, 1.

PLC station number: 0.

Control area/status area: None.

**B. Definition of controller Read/Write address****Registers**

Register Type	Format	Read/Write Range		Data Length
		Word No.	Bit No.	
RAM memory	Rn	n: 00-FF (Hex)	N/A	DWord
Flash memory	Fn	n: 00-FF (Hex)	N/A	DWord
Internal Register	IRn	n: 0-31	N/A	Word

**Contacts**

Contact Type	Format	Read/Write Range	
		Word No.	Bit No.
BIT_DEVICE_RB	RBn.b	n: 00-FF (Hex)	b: 0-31
BIT_DEVICE_FB	FBn.b	n: 00-FF (Hex)	b: 0-31
BIT_DEVICE_T0	T0n	N/A	n: 0
BIT_DEVICE_T1	T1n	N/A	n: 0
BIT_DEVICE_T2	T2n	N/A	n: 0
BIT_DEVICE_RST	RSTn	N/A	n: 0
BIT_DEVICE_CPR	CPRn	n: 00-FF (Hex)	N/A
BIT_DEVICE_CPF	CPFn	n: 00-FF (Hex)	N/A

 **NOTE**

- 1) RB and FB are the bit access of Ram/Flash memory. Therefore, RB0x21.14 indicates bit 14 of Ram memory 0x21.
- 2) T0, T1 and T2 is virtual device for simulating Trajectory Generator Command. The number of 0, 1 and 2 indicates the subcommand of that command, so only bit 0 is acceptable.
- 3) RST is for simulating Reset Command, so only bit 0 is acceptable.
- 4) CPR and CPF are for simulating Copy Command of Ram and Flash individually. The address (n) after CPR and CPF is just the copy address for Ram/Flash memory. For example, CPRCA indicates that the content of Ram memory 0xCA will be copied into Flash memory 0xCA and CPFA6 indicates that the content of Flash memory 0xA6 will be copied into Ram memory 0xA6.
- 5) T0, T1, T2, RST, CPR, CPF are all write-only and they can not be used on Reset button.



C. Connections (Connector Pinouts)

**RS-232**

DOP series 9 pin D-SUB male (RS-232)	Controller 9 pin D-SUB female (RS-232)
RXD (2)	RS-232 TxD
TXD (3)	RS-232 RxD
GND (5)	Signal Ground

## Danfoss VLT 2800 (FC Protocol)

[Back to Table](#)

## A. HMI factory setting

Baud rate: 9600, 8, Even, 1, RS-485.

PLC station number: 1.

Control area/status area: None / None.



- 1) Delta HMI can be connected to for VLT-2800, 5000, 6000, 7000 controllers.
- 2) Each data length format of Danfoss AC drive parameter is not fixed, therefore, "Multiple Duplicate" function is not provided.
- 3) Max. supported alarm number is 16. If the alarm number is over 16, a fault will occur.
- 4) Does not support "optimum read/write" characteristic.
- 5) If the selected element is a string, the minimum data length should be more than 2.

## B. Definition of controller Read/Write address

## Registers

Register Type	Format	Read/Write Range		
		Word No.	Bit No.	
			Low Byte	High Byte
			Index No.	
Parameter	Pn:l	n: 0 ~ 999	0	l: 0 ~ 31
Control Word	CTRWD	0	N/A	N/A
Status Word	STAWD	0	N/A	N/A

- Index No : If the index No. is not used, its default setting will be 0. The default setting of index No. for parameter P606 ~ P617 is 1.
- Please notice that it is necessary to input the index No. when using some parameters of Danfoss controllers. At this time, please pay close attention on the setting range of index number. If the setting range is not started from 0, the parameter read & write failure will occur. For example, the index No. setting range of the parameter P615 is from 1 to 20, if the users do not input the index No., the system will assume the index number is 0 (default setting) and the a fault will occur when the users read or write the parameter.
- CTRWD: Write-only. (Can not be used on the devices which can display the value or input value. It is recommended to be used on the setting value/setting constant (button), or marco function.)
- STAWD: Read-only.
- Control & Status Word: Please refer to the explanation on the next page.

**Contacts**

Contact Type	Format	Read/Write Range		
		Word No.	Bit No.	
		Element No.	Low Byte	High Byte
			Bits	Index No.
Parameter	Pn:l.b	n: 0 ~ 999	b: 0 ~ 31	l: 0 ~ 31

➤ **Bit No** : Low byte stores Bit address. High byte stores index number.

**C. Connections (Connector Pinouts)**

**RS-485**

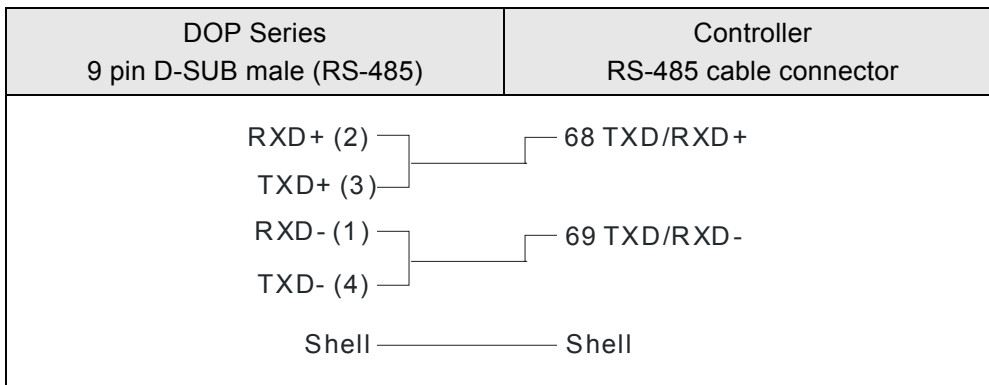

**Explanation of Control Word & Status Word**

**Control Word**

Bit	Bit = 0	Bit = 1
15	No Function	Reversing
14	Choice of Setup 2 (msb)	
13	Choice of Setup 1 (lsb)	
12	No Function	Relay 04 activated
11	No Function	Relay 01 activated
10	Data Not Valid	Valid
9	Ramp 1	Ramp2
8	Jog 1 OFF	ON
7	No Function	Reset
6	Ramp Stop	Start
5	Hold	Ramp Enable
4	Quick-Stop	Ramp
3	Coasting	Enable
2	DC Brake	Ramp
1	Preset reference choice msb	
0	Preset reference choice msb	

➤ When Bit 10 = 1 (Data Valid), the Control Word is valid.

**Status Word**

Bit	Bit = 0	Bit = 1
15	Timer OK	Above limit
14	Torque OK	Above limit
13	Voltage OK	Above limit
12	Temperature OK	Over-Temp, auto-start pending
11	Not Running	Running
10	Out of Range	Frequency OK
9	Local Control	Bus Control
8	Speed $\neq$ reference	Speed = reference
7	No Warning	Warning
6	Reserved	
5	Reserved	
4	Reserved	
3	No Fault	Trip
2	Coasting	Enabled
1	VLT not ready	Ready
0	Control not ready	Ready

## Emerson EC20 Series PLC

[Back to Table](#)**A. HMI factory setting**

Baud rate: 19200, 8, Even, 1 (RS-232).

PLC station number: 0.

Control area/status area: D0 / D10.

**B. Definition of controller Read/Write address****Registers**

Register Type	Format	Read/Write Range		Data Length
		<u>Word No.</u>	<u>Bit No.</u>	
Data Word	Dn	n: 0-7999	N/A	Word
Special Data Word	SDn	n: 0-255	N/A	Word
Data Word	Zn	n: 0-15	N/A	Word
Timer	Tn	n: 0-255	N/A	Word
Counter	Cn	n: 0-199	N/A	Word
DoubleWord Counter	CDWn	n: 200-255	N/A	DWord
DoubleWord Data Word	DDWn	n: 0-7998	N/A	DWord

**Contacts**

Contact Type	Format	Read/Write Range	
		<u>Word No.</u>	<u>Bit No.</u>
External Output Relay	Yb	N/A	b: 0-377(Octal)
External Input Relay	Xb	N/A	b: 0-377(Octal)
Internal Relay	Mb	N/A	b: 0-1999
Special Internal Relay	SMb	N/A	b: 0-255
Status Relay	Sb	N/A	b: 0-991
Timer	Tb	N/A	b: 0-255
Counter	Cb	N/A	b: 0-255

**NOTE**

PLC Communication Settings:

- 1) Emerson EC20 series PLC has two communication ports, COM0 and COM1. They are provided for the communication protocol for connecting to PC, Modbus communication protocol and user-defined protocol. The default setting is COM0 to be enabled only, so the user needs to set the communication mode as Modbus RTU via PC software before using it.
- 2) COM1 supports RS-232 and RS-485.

- 3) Please note that not all of the addresses can be written when reading SM and SD device. We recommend the user not to set all of the addresses as write address except when setting parameters.

**C. Connections (Connector Pinouts)**

**RS-232**

DOP series 9 pin D-SUB male (RS-232)	Controller COM1
RXD (2)	TXD
TXD (3)	RXD
GND (5)	GND

**RS-485**

DOP series 9 pin D-SUB male (RS-232)	Controller COM1
D- (1) D- (4)	(3) RS485+
D+ (2) D+ (3)	(4) RS485-
GND (5)	GND

## Facon FB Series PLC

[Back to Table](#)

## A. HMI factory settings

Baud rate: 9600, 7, Even, 1.

Controller Station number: 1.

Control area/status area: R0 / R10.

## B. Definition of controller Read/Write address

## Registers

Register Type	Format	Read/Write range		Data length
		Word No.	Bit No.	
Input Relay	WXn	n: 0 ~ 9992	N/A	Byte
Output Relay	WYn	n: 0 ~ 9992	N/A	Byte
Internal Relay	WMn	n: 0 ~ 9992	N/A	Byte
Step Relay	WSn	n: 0 ~ 9992	N/A	Byte
Data Register	Rn	n: 0 ~ 65534	N/A	Word
Data Register	Dn	n: 0 ~ 65534	N/A	Word
Timer Present Value	RTn	n: 0 ~ 9999	N/A	Word
Counter Present Value	RCn	n: 0 ~ 9999	N/A	Word
Data Register	DRCn	n: 200 ~ 255	N/A	Double Word

➤ Input Relay / Output Relay / Internal Relay / Special Relay: Address must be the multiple of 8.

## Contacts

Contact type	Format	Read/Write range	
		Word No.	Bit No.
Input Relay	Xn	N/A	n: 0 ~ 9999
Output Relay	Yn	N/A	n: 0 ~ 9999
Internal Relay	Mn	N/A	n: 0 ~ 9999
Step Relay	Sn	N/A	n: 0 ~ 9999
Timer Flag	Tn	N/A	n: 0 ~ 9999
Counter Flag	Cn	N/A	n: 0 ~ 9999





## Festo PLC

[Back to Table](#)**A. HMI factory settings**

Baud rate: 9600, 8, None, 1.

Controller Station number: 0. (no PLC station number in protocol)

Control area/status area: R0 / R10.



1) Connectable PLC: FEC-FC Model

**B. Definition of controller Read/Write address****Registers**

Register Type	Format	Word No.	Bit No.	Data Size
WORD_DEVICE_IW	lwn	n: 0 ~ 255	N/A	Word
WORD_DEVICE_OW	Own	n: 0 ~ 255	N/A	Word
WORD_DEVICE_FW	FWn	n: 0 ~ 9999	N/A	Word
WORD_DEVICE_TW	TWn	n: 0 ~ 255	N/A	Word
WORD_DEVICE_CW	CWn	n: 0 ~ 255	N/A	Word
WORD_DEVICE_R	Rn	n: 0 ~ 255	N/A	Word
WORD_DEVICE_TP	TPn	n: 0 ~ 255	N/A	Word
WORD_DEVICE_CP	CPn	n: 0 ~ 255	N/A	Word

**Contacts**

Register Type	Format	Word No.	Bit No.
BIT_DEVICE_I	ln.b	n: 0 ~ 255	b: 0 ~ 15
BIT_DEVICE_O	On.b	n: 0 ~ 255	b: 0 ~ 15
BIT_DEVICE_F	Fn.b	n: 0 ~ 9999	b: 0 ~ 15
BIT_DEVICE_T	Tn	N/A	n: 0 ~ 255
BIT_DEVICE_C	Cn	N/A	n: 0 ~ 255
BIT_DEVICE_TON	TONn	N/A	n: 0 ~ 255
BIT_DEVICE_TOFF	TOFFn	N/A	n: 0 ~ 255

- BIT\_DEVICE\_T / BIT\_DEVICE\_C / BIT\_DEVICE\_TON / BIT\_DEVICE\_TOFF: Only 1 Bit can be transferred for each communication.
- Only 1 Bit or 1 Word can be transferred for each write command.

## C. Connections



- 
- 1) Communication port of PLC: COM port
  - 2) It needs to use the dedicated cable for FESTO controllers → Cable for transferring TTL to RS-232 and it is 6 pin RJ-12 connector at PLC side.

## GE Fanuc 90 Series SNP PLC

[Back to Table](#)

## A. HMI factory settings

Baud rate: 19200, 8, ODD, 1.

Controller Station number: 0. (no PLC station number in protocol, therefore, only 1(HMI) to 1 (PLC) communication is allowed.)

Control area/status area: %R1 / %R10.



- 1) Please notice that no PLC station number in protocol, therefore, only 1(HMI) to 1 (PLC) communication is allowed.
- 2) If the PLC enabled "Check Password" function, the user needs to set the password by clicking Option > Configuration > Communication. The user can find Controller Settings and set PLC password on Communication Tab in the Configuration dialog box. Please enter a 4-digit password (If entering a password that exceeds 4-digit number, only the first 4-digit number is valid).

## B. Definition of controller Read/Write address

## Registers

Register Type	Format	Read/Write range		Data length
		Word No.	Bit No.	
Discrete Inputs	%In	n: 1 ~ 12288	N/A	Word (the multiple of 16 + 1)
Discrete Outputs	%Qn	n: 1 ~ 12288	N/A	Word (the multiple of 16 + 1)
Discrete Temporaries	%Tn	n: 1 ~ 256	N/A	Word (the multiple of 16 + 1)
Discrete Internals	%Mn	n: 1 ~ 12288	N/A	Word (the multiple of 16 + 1)
%SA Discretes	%SAn	n: 1 ~ 128	N/A	Word (the multiple of 16 + 1)
%SB Discretes	%SBn	n: 1 ~ 128	N/A	Word (the multiple of 16 + 1)
%SC Discretes	%SCn	n: 1 ~ 128	N/A	Word (the multiple of 16 + 1)
%S Discretes	%S-n	n: 1 ~ 128	N/A	Word (the multiple of 16 + 1)
Genius Global Data	%Gn	n: 1 ~ 7680	N/A	Word (the multiple of 16 + 1)
Registers	%Rn	n: 1 ~ 16384	N/A	Word
Analog Inputs	%AIn	n: 1 ~ 8192	N/A	Word
Analog Outputs	%AQn	n: 1 ~ 8192	N/A	Word

**Contacts**

Contact Type	Format	Read/Write range	
		Word No.	Bit No.
Discrete Inputs	%In	N/A	n: 1 ~ 12288
Discrete Outputs	%Qn	N/A	n: 1 ~ 12288
Discrete Temporaries	%Tn	N/A	n: 1 ~ 256
Discrete Internals	%Mn	N/A	n: 1 ~ 12288
%SA Discretes	%SAn	N/A	n: 1 ~ 128
%SB Discretes	%SBn	N/A	n: 1 ~ 128
%SC Discretes	%SCn	N/A	n: 1 ~ 128
%S Discretes	%-Sn	N/A	n: 1 ~ 128
Genius Global Data	%Gn	N/A	n: 1 ~ 7680

**C. Connections (Connector Pinouts)**

**RS-232**

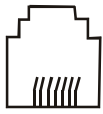
DOP 9 pin D-SUB male (RS-232)	Controller RJ-45 cable connector (RS-232)	Controller RJ-45 cable connector (RS-232)
<p>RXD (2) ————— (5) TXD</p> <p>TXD (3) ————— (6) RXD</p> <p>GND (5) ————— (4) GND</p>	 <p>1 → 8 Top View</p>	

**RS-422**

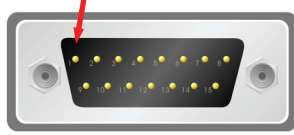
DOP Series 9 pin D-SUB male (RS-232)	Controller 15 pin male (RS-232)	Controller 15 pin male (RS-232)
<p>RXD- (1) ————— (12) SD(A')</p> <p>RXD+ (2) ————— (13) SD(B')</p> <p>TXD+ (3) ————— (11) RD(B)</p> <p>TXD- (4) ————— (10) RD(A)</p> <p>(9) RD(*)<sup>(NOTE1)</sup></p> <p>(6) RTS(A)</p> <p>(15) CTS(A')</p> <p>(8) CTS(B)</p> <p>(14) RTS(B')</p>	 <p>Pin1</p> <p>Top View</p>	

**NOTE**

- 1) (9) RD(\*) should be connected to 10(RD)(A) in serial. But if connecting PLC model is Series 90-70 PLC IC697CPU731 and IC697CPU771, (9) RD(\*) needs to be connected to 11(RD)(B).

## Hitachi EH Series PLC

[Back to Table](#)

## A. HMI factory settings

Baud rate: 19200, 7, EVEN, 1.

Controller station number: 0.

Control area/status area: WR0 / WR10.

## B. Definition of controller Read/Write address

## Registers

Register Type	Format	Read/Write Range				Data Length
		Word No.		Bit No.		
External Input WX	WXrusn	s: 0-A	n: 0-7	r: 0-4	N/A	Word
External Output WY	WYrusn			u: 0-4		Word
Internal Output WR	WRn	n: 0-C3FF		N/A		Word
Special Internal Output WR	WRn	n: F000-F1FF		N/A		Word
Shared Internal Output WM	WMn	n: 0-3FF		N/A		Word
CPU Link Area 1 WL	WLn	n: 0-3FF		N/A		Word
CPU Link Area 2 WL	WLn	n: 1000-13FF		N/A		Word
Timer/Counter TC	TCn	n: 0-511		N/A		Word

## Contacts

Register Type	Format	Read/Write Range			
		Word No.		Bit No.	
External Input X	Xrusb	s: 0-A	N/A	r: 0-4	b: 0-95
External Output Y	Yrusb			u: 0-4	
Internal Output R	Rb	N/A		b: 0-7FF	
Shared Internal Output M	Mnb	n: 0-3FF		b: 0-F	
CPU Link Area 1 L	Lnb	n: 0-3FF		b: 0-F	
CPU Link Area 2 L	Lnb	n: 1000-13FF		b: 0-F	
On Delay Timer TD	TDb	N/A		b: 0-255	
Single-shot Timer SS	SSb	N/A		b: 0-255	
Up Counter CU	CUb	N/A		b: 0-511	
Up-down Counter up input CTU	CTUb	N/A		b: 0-511	
Up-down Counter down input CTD	CTDb	N/A		b: 0-511	
Up-down Counter down output CT	CTb	N/A		b: 0-511	
Progress Value Clear CL	CLb	N/A		b: 0-511	
Rising Edge Detection DIF	DIFb	N/A		b: 0-511	
Falling Edge Detection DFN	DFNb	N/A		b: 0-511	



### 1) Communication Settings:

- In Hitachi EH series PLC, only port 1 can be used for communication through procedure 2. The user can select procedure type via DIP switch and specific Special Internal Input (WR).
- In Hitachi EH-150 series PLC, only EH-CPU\*\*\*A/448/516/548 can use procedure 2.
- It needs to set the external I/O (WX, WY, X, Y) of EH series PLC first or HMI cannot read and write their addresses.
- Hitachi EH series PLC and PC can be connected only by procedure 1 (@19200bps)

### 2) CPU Relevant Notice:

#### EH-150

- DIP5 should be set to ON.
- If DIP5 is set to ON, PLC will determine the proper procedure (1 or 2) by the value of WRf037. When setting the address, the highest bit of write value must be 1 and then PLC can write the value into other seven bits. The data will not be lost even when the power of PLC is cut off. Therefore,
  - i) Write the value 0x8000 into the address. After restart PLC, the address value will become 0x0000 and perform communication by procedure 1.
  - ii) Write the value 0xC000 into the address. After restart PLC, the address value will become 0x4000 and perform communication by procedure 2.
- Use DIP3 and DIP4 to set the communication speed of port 1.
  - i) When DIP3 is ON and DIP4 is OFF, the communication speed is 19200bps.
- Use DIP6, PHL to set the communication speed of port 2.
  - i) When DIP6 is ON and PHL is OFF, the communication speed is 19200bps.
  - ii) The EH-150 PLC is a "Base Unit" which has a built-in CPU module. This unit allows easy connection of extension module, such as "External I/O".

#### MicroEH

- DIP5 is used to set communication speed.
  - i) When SW1 is ON, the communication speed is 19200bps.
- MicroEH PLC will determine the proper procedure (1 or 2) by the value of WRf01a. Different than EH-150, when setting the address, the highest bit of write value does not need to be 1. But the data will be lost even the power of PLC is cut off. However, if set the value of R7f6 to 1, the data of WRf01a will be saved into Flash memory.
  - i) 0x0000 for procedure 1.
  - ii) 0x8000 for procedure 2.
  - iii) If the PLC uses procedure 2 and saves the data into Flash memory, it cannot connect to the peripheral devices and programs (Ladder Editor) that only support procedure 1.
  - iv) Standard External I/O built in MicroEH PLC are listed as below:
    - Digital Type

- slot 0: X48
- slot 1: Y32
- slot 2: empty16
- Analog Type
  - slot 3: X4W
  - slot 4: Y4W

3) Communication Protocol:

External I/O (X, Y, WX, WY)

- Address rules:[r][u][s][n/b].
  - i) Word no/Bit no [n/b]
  - ii) Slot number [s]
  - iii) Unit number [u]
  - iv) Remote number [r]
    - Only support EH-150
  - v) ex1: WX103 represents unit 1, word 3 of slot 0
  - vi) ex2: X103 represents bit 3 of slot 1
  - vii) ex3: X113 represents bit 13 of slot 1
  - viii) ex4: Y2004 represents unit 2, bit 4 of slot 0
  - ix) ex5: Y2104 represents unit 2, bit 4 of slot 1
- External I/O (X, Y, WX, WY) cannot read and write several addresses one time so they do not support “optimum read/write” characteristic.

Internal Output

- Shared Internal Output (M, WM) read and write the same address. For example,
  - i) M3ab and WM3a: the read and write address of M3ab is the bit b of WM3a.
- CPU Link Area (L, WL) are the same as Shared Internal Output (M, WM). CPU Link Area (L, WL) also read and write the same address.
  - i) Only support EH-150.

**C. Connections (Connector Pinouts)**

**RS-232**

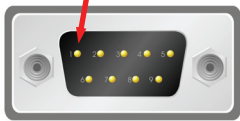
DOP Series 9 pin D-SUB male (RS-232)	Controller 9 pin D-SUB male (RS-232)	Controller 9 pin D-SUB male (RS-232)
RXD (2) ————— (5) SD1		 <p>Pin1</p> <p>Top View</p>
TXD (3) ————— (6) RD1		
GND (5) ————— (1) SG1		
RTS (7) ————— (7) DR1		
CTS (8) ————— (8) RS1		

**HUST CNC Controller**

[Back to Table](#)

**A. HMI factory settings**

Baud rate: 9600, 7, EVEN, 2.

Controller station number: 0.

Control area/status area: W0 / W10.

**B. Definition of controller Read/Write address**

**Registers**

Register Type	Format	Read/Write Range		Data Length
		Word No.	Bit No.	
Word Register	Wn	n: 0 ~ 13500	N/A	Word
Double Word Register	Dn	n: 0 ~ 13500	N/A	Double Word



1) The unit for Hust CNC controller is D Word and Wn is the low word of Dn.

**Contacts**

Contact Type	Format	Read/Write range	
		Word No.	Bit No.
BIT_DEVICE_B	Bm.n	m: 0 ~ 13500	n: 0 ~ 31
BIT_DEVICE_I	In	N/A	n: 0 ~ 255 (8 DW)
BIT_DEVICE_O	On	N/A	n: 0 ~ 255 (8 DW)
BIT_DEVICE_C	Cn	N/A	n: 0 ~ 255 (8 DW)
BIT_DEVICE_S	Sn	N/A	n: 0 ~ 255 (8 DW)
BIT_DEVICE_A	An	N/A	n: 0 ~ 1023 (32 DW)

**C. Connections (Connector Pinouts)**

**RS-232**

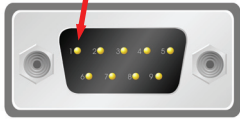
DOP Series 9 pin D-SUB male (RS-232)	Controller 9 pin D-SUB male (RS-232)	Controller 9 pin D-SUB male (RS-232)
RXD (2)	(2) TXD	 <p>Top View</p>
TXD (3)	(3) RXD	
GND (5)	(5) SG	
	(8) RTS	
	(7) CTS	



## Jetter Nano Series PLC

[Back to Table](#)

## A. HMI factory settings

Baud rate: 9600, 8, EVEN, 1 (RS-232).

Controller station number: 0. (no PLC station number in protocol, therefore, only 1(HMI) to 1 (PLC) communication is allowed.)

Control area/status area: WR0 / WR10.



- 1) Please notice that no PLC station number in protocol, therefore, only 1(HMI) to 1 (PLC) communication is allowed.
- 2) Only 1 Bit or 1 Word can be transferred for each communication.
- 3) In general, each register occupies max. 24 Bits. However, some registers occupies 8 Bits only.
- 4) Because the initial time of this controller is longer, it is recommended to set HMI startup delay time (Recommended time is 10 seconds).
- 5) When the register R is used for Double Word device, please set its format as signed format. (The default format in Screen Editor is signed format)

## B. Definition of controller Read/Write address

## Registers

Register Type	Format	Read/Write Range		Data Length
		Word No.	Bit No.	
16 Bits Register	WRn	n: 0 ~ 32767	N/A	16 Bits
32 Bits Register	Rn	n: 0 ~ 32767	N/A	24 Bits

Only the first 16 bits are used for WRn registers.

Only the first 24 bits are used for Rn registers, the highest 8 bits (Bit 24 ~ 31) are set to 0 by default setting. (24-bit Integer : If in decimal format, the range is -8388608 ~ +8388607. If in hexadecimal format, the range is 0x000000 ~ 0xFFFFFFFF.)



- 1) The difference between WRn and Rn:
  - When using devices that the data length is in Word, only Bit 0 ~ 15 are valid for both of WRn and Rn registers.
  - When using devices that the data length is in Double Word, if the read/write address format is set to WRn, the Bit 0 ~ 15 of WRn register is the low word of a read/write value, the Bit 0 ~ 15 of WRn+1 register is the high word of a read/write value.

if the read/write address format is set to Rn, only Bit 0 ~ 23 are valid for Rn registers.

**(Notice: As the Jetter controller is a 24-bit format controller, the valid setting range is 24 Bits. If exceeds this range, HMI will stop read/write operation and show “...Value is Incorrect” on the screen. So, please do not set any bit on Bit24 ~ Bit31 (Bit24 ~ Bit31 cannot be written).**

- When using devices that the data length is in m Words,  
 if the read/write address format is set to WRn, the Bit 0 ~ 15 of WRn register is the lowest word of a read/write value and the Bit 0 ~ 15 of WRn+m-1 register is the highest word of a read/write value.  
 if the read/write address format is set to Rn, the Bit 0 ~ 23 of Rn register is the lowest word of a read/write value and the Bit 0 ~ 23 of Rn+1 register is the highest word of a read/write value.  
 Each register is regards as a “Double Word”. The value of Bit24 ~ Bit31 is 0.

**Contacts**

Contact type	Format	Read/Write Range	
		Word No.	Bit No.
Input Relay	Inbb	n: 1 ~ 32	bb: 01 ~ 08
Output Relay	Onbb	n: 1 ~ 32	bb: 01 ~ 08
Flag Relay	Fn	N/A	n: 0 ~ 32767

**C. Connections (Connector Pinouts)**

**RS-232**

DOP Series 9 pin D-SUB male (RS-232)	Controller 9 pin D-SUB male (RS-232)	Controller 9 pin D-SUB male (RS-232)
RXD (2) ————— (2) TXD TXD (3) ————— (3) RXD GND (5) ————— (7) GND		 <p>Pin1</p> <p>Top View</p>

- The pin definition of the cable of Jetter controller is different than the general RS-232 cable. Please pay close attention.

## Jetter JC Series PLC

[Back to Table](#)**A. HMI factory settings**

Baud rate: 9600, 8, EVEN, 1 (RS-232).

Controller station number: 0. (no PLC station number in protocol, therefore, only 1(HMI) to 1 (PLC) communication is allowed.)

Control area/status area: WR0 / WR10.



- 1) Please notice that no PLC station number in protocol, therefore, only 1(HMI) to 1 (PLC) communication is allowed.
- 2) Only 1 Bit or 1 Word / 2 Words can be transferred for each read and write command.

**B. Definition of controller Read/Write address****Registers**

Register Type	Format	Read/Write Range		Data Length
		Word No.	Bit No.	
16 Bits Register	WRn	n: 0 ~ 32767	N/A	16 Bits
32 Bits Register	Rn	n: 0 ~ 32767	N/A	24 Bits

The characteristics of WRn and Rn of JC series are the same as the Nano series. Please refer to the section that introduces [Jetter Nano Series PLC](#).

**Contacts**

Contact type	Format	Read/Write Range	
		Word No.	Bit No.
Input Relay	Inbb	n: 1 ~ 32	bb: 01 ~ 16
Output Relay	Onbb	n: 1 ~ 32	bb: 01 ~ 16
Flag Relay	Fn	N/A	n: 0 ~ 32767

C. Connections (Connector Pinouts)

**RS-232**

DOP Series 9 pin D-SUB male (RS-232)	Controller 8 pin Mini DIN male (RS-232)	Controller 8 pin Mini DIN male (RS-232)
<p>RXD (2) ————— (8) TXD</p> <p>TXD (3) ————— (4) RXD</p> <p>GND (5) ————— (2) GND</p>		 <p>Top View</p>

## Keyence KV/KZ Series

[Back to Table](#)

## A. HMI factory settings

Baud rate: 9600, 8, EVEN, 1 (RS-232).

Controller station number: 0. (no PLC station number in protocol, therefore, only 1(HMI) to 1 (PLC) communication is allowed.)

Control area/status area: DM-0 / DM-10.



- 1) Please notice that no PLC station number in protocol, therefore, only 1(HMI) to 1 (PLC) communication is allowed.
- 2) Only 1 Bit or 1 Word can be transferred for each communication. (Communication speed is slow.)

## B. Definition of controller Read/Write address

## Registers

Register Type	Format	Read/Write Range		Data Length
		Word No.	Bit No.	
Timer	T-nnn	nnn: 0 ~ 199	N/A	Word
Counter	C-nnn	nnn: 0 ~ 199	N/A	Word
High-speed Counter	CTH-n	n: 0 ~ 1	N/A	Word
High-speed Counter Comparator	CTC-n	n: 0 ~ 3	N/A	Word
Data Memory	DM-nnnn	nnnn: 0 ~ 1999	N/A	Word
Temporary Data Memory	TM-nn	nn: 0 ~ 31	N/A	Word
Timer Preset Value	PT-nnn	nnn: 0 ~ 199	N/A	Word
Counter Preset Value	PC-nnn	nnn: 0 ~ 199	N/A	Word
CTC Preset Value	PCTC-n	n: 0 ~ 3	N/A	Word

## Contacts

Contact type	Format	Read/Write Range	
		Word No.	Bit No.
Relay	R-nnnbb	nnn: 0 ~ 69	bb: 00 ~ 15
Timer	T-nnn	N/A	nnn: 0 ~ 199
Counter	C-nnn	N/A	nnn: 0 ~ 199
High-speed counter comparator	CTC-n	N/A	n: 0 ~ 3

**NOTE**

When using the protocol format of KV series and connecting to KZ-80T PLC, some errors occur. Please refer to the following description:

- 1) Readable Timer address is not continuous. For example, T-0 ~ T-9 can be read, T10 cannot be read, T11 ~ T20 can be read, T21 ~ T50 cannot be read, ...etc.
- 2) Counter cannot be read. For example,  
 Registers: C- (Counter), CTH- (High-speed counter), CTC- (High-speed counter comparator), PC- (Counter preset value), PCTC- (CTC preset value) they all cannot be read.  
 Contacts: C- (Counter), CTC- (High-speed counter comparator) they all cannot be read also.

**C. Connections (Connector Pinouts)**

**RS-232**

**KV Series**

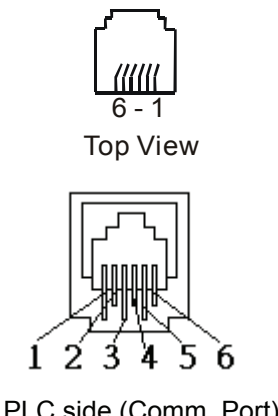
DOP 9 pin D-SUB male (RS-232)	Controller RJ-11 cable connector (RS-232)	Controller RJ-11 cable connector (RS-232)
RXD (2) ————— (3) SD TXD (3) ————— (5) RD GND (5) ————— (4) SG	 <p>6 - 1 Top View</p> <p>1 2 3 4 5 6 PLC side (Comm. Port)</p>	

**KZ Series**

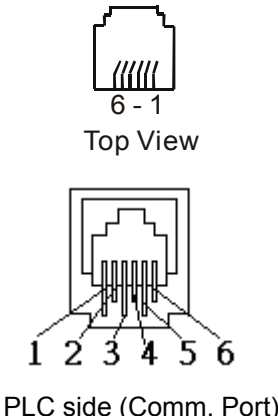
DOP 9 pin D-SUB male (RS-232)	Controller RJ-11 cable connector (RS-232)	Controller RJ-11 cable connector (RS-232)
RXD (2) ————— (5) SD TXD (3) ————— (3) RD GND (5) ————— (4) SG	 <p>6 - 1 Top View</p> <p>1 2 3 4 5 6 PLC side (Comm. Port)</p>	



- 
- 1) Communication Cable: The pins of SD and RD of KZ-80T and KV Series are reverse.

## Koyo SU/DL Series

[Back to Table](#)**A. HMI factory settings**

Baud rate: 9600, 8, ODD, 1 (RS-232).

Controller station number: 1.

Control area/status area: V1400 / V1410.

**B. Definition of controller Read/Write address****Registers**

Register Type	Format	Read/Write Range		Data Length
		Word No.	Bit No.	
Timer Accumulated	Vn	n: 0 ~ 177 (octal)	N/A	Word
Counter Accumulated	Vn	n: 1000 ~ 1177 (octal)	N/A	Word
V Memory	Vn	n: 1400 ~ 7777 (octal)	N/A	Word
Linker Relays	Vn	n: 40000 ~ 40037 (octal)	N/A	Word
Input Status	Vn	n: 40400 ~ 40423 (octal)	N/A	Word
Output Status	Vn	n: 40500 ~ 40523 (octal)	N/A	Word
Control Relays	Vn	n: 40600 ~ 40635 (octal)	N/A	Word
Stage	Vn	n: 41000 ~ 41027 (octal)	N/A	Word
Timer Status	Vn	n: 41100 ~ 41107 (octal)	N/A	Word
Counter Status	Vn	n: 41140 ~ 41147 (octal)	N/A	Word
Spec. Relay 1	Vn	n: 41200 ~ 41205 (octal)	N/A	Word
Spec. Relay 2	Vn	n: 41216 ~ 41230 (octal)	N/A	Word

**Contacts**

Contact type	Format	Read/Write Range	
		Word No.	Bit No.
Linker Relays	GXn	N/A	n: 0 ~ 777 (octal)
Input Status	Xn	N/A	n: 0 ~ 477 (octal)
Output Status	Yn	N/A	n: 0 ~ 477 (octal)
Control Relays	Cn	N/A	n: 0 ~ 737 (octal)
Stage	Sn	N/A	n: 0 ~ 577 (octal)
Timer Status	Tn	N/A	n: 0 ~ 177 (octal)
Counter Status	CTn	N/A	n: 0 ~ 177 (octal)
Spec. Relay 1	SPn	N/A	n: 0 ~ 137 (octal)
Spec. Relay 2	SPn	N/A	n: 320 ~ 617 (octal)



C. Connections (Connector Pinouts)

**RS-232**

DOP 9 pin D-SUB male (RS-232)	Controller RJ-11 cable connector (RS-232)	Controller RJ-11 cable connector (RS-232)
<p>RXD(2) ————— (4)TXD</p> <p>TXD(3) ————— (3)RXD</p> <p>GND(5) ————┐                   └───┬─── (1)GND                           └─── (6)GND</p>		 <p>1 - 6 Top View</p>

## Koyo K-Sequence

[Back to Table](#)

## A. HMI factory settings

Baud rate: 9600, 8, ODD, 1 (RS-232).

Controller station number: 1.

Control area/status area: R1400 / R1420.



- 1) If read / write address exceeds the valid range, HMI will stop read/write operation and show "...Error 6..... Command Can Not be Executed...." on the screen.

## B. Definition of controller Read/Write address

## Registers

Register Type	Format	Read/Write Range		Data Length
		Word No.	Bit No.	
Input Status	Xnnnn	nnnn: 0 ~ 1760 (octal)	N/A	Word
Output Status	Ynnnn	nnnn: 0 ~ 1760 (octal)	N/A	Word
Link Relays	GXnnnn	nnnn: 0 ~ 3760 (octal)	N/A	Word
Relays	GQnnnn	nnnn: 0 ~ 3760 (octal)	N/A	Word
Relays	Mnnnn	nnnn: 0 ~ 3760 (octal)	N/A	Word
Stage	Snnnn	nnnn: 0 ~ 1760 (octal)	N/A	Word
Timer Status	Tnnn	nnn: 0 ~ 360 (octal)	N/A	Word
Control Relays	Cnnn	nnn: 0 ~ 360 (octal)	N/A	Word
Special Relay 1	SPnnn	nnn: 0 ~ 760 (octal)	N/A	Word
Register	Rnnnnn	nnnnn: 0 ~ 41237 (octal)	N/A	Word
Register	Pnnnnn	nnnnn: 0 ~ 37777 (octal)	N/A	Word

- nnnn: Is in octal format and must be the multiple of 16 except for R and P.

## Contacts

Contact type	Format	Read/Write Range	
		Word No.	Bit No.
Input Status	Xnnnn	N/A	nnnn: 0 ~ 1777 (octal)
Output Status	Ynnnn	N/A	nnnn: 0 ~ 1777 (octal)
Linker Relays	GXnnnn	N/A	nnnn: 0 ~ 3777 (octal)
Relays	GQnnnn	N/A	nnnn: 0 ~ 3777 (octal)
Control Relays	Mnnnn	N/A	nnnn: 0 ~ 3777 (octal)
Stage	Snnnn	N/A	nnnn: 0 ~ 1777 (octal)
Timer Status	Tnnn	N/A	nnn: 0 ~ 377 (octal)

Contact type	Format	Read/Write Range	
		Word No.	Bit No.
Counter Status	Cnnn	N/A	nnn: 0 ~ 377 (octal)
Spec. Relay 1	SPnnn	N/A	nnn: 0 ~ 777 (octal)

**C. Connections (Connector Pinouts)**

**RS-232**

**Port 0 Communication Cable**

DOP 9 pin D-SUB male (RS-232)	Controller RJ-11 cable connector (RS-232)	Controller RJ-11 cable connector (RS-232)
RXD(2) ————— (4)TXD TXD(3) ————— (3)RXD GND(5) ————— (1)GND <span style="margin-left: 300px;">(6)GND (Note 1)</span>	 1 - 6 Top View	

- If pin 6 is not grounded, a communication error may occur when connecting to a CKD SM 24R controller. Ensure that pin 6 is well grounded. This will not cause any problems when connecting to SN32DRA controller.

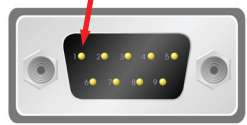
DOP Series 9 pin D-SUB male (RS-232)	Controller 9 pin D-SUB male (RS-232)	Controller 9 pin D-SUB male (RS-232)
RXD (2) ————— (3) TXD TXD (3) ————— (2) RXD GND (5) ————— (5) SG	 Pin1 Top View	

**RS-485**

**Port 1 Communication Cable**

DOP 9 pin D-SUB male (RS-485)	DOP 9 pin D-SUB male (RS-485)
D- (1) ————— D- D- (4) ————— D+ (2) ————— D+ D+ (3) —————	

**The corresponding registers of CCM2 and K-Sequence****Address Corresponding Relationship:**

CCM2	K sequence	SN32DRA
V	R	R
X	X	I
Y	Y	Q
C	M	M
S	S	S
T	T	T
CT	C	C
SP	SP	SP

**A. HMI factory settings**

Baud rate: 9600, 7, EVEN, 1 (Baudrate: 1200/2400/4800/9600/19200).

Controller station number: 1 (1~99).

Control area/status area: None / None.



- 1) Please pay close attention to each pin definition of cable connectors.
- 2) Ensure not to use the general RS-232 5-pin cable. This is because if pin 2, 3, 5, 7, 8 are all connected to the drive, the drive can not recognize the communication signal and can not identify what kind of communication it is.
- 3) For more detailed information of pin definition of cable connectors, please refer to the [C. Connections \(Connector Pinouts\)](#) of Lenze LECOM-A/B Protocol controller.
- 4) Ensure the HMI communication data format (The communication data written into the drive) is correct. The Word "m" in the following table is used to specify the HMI communication data format.
- 5) Ensure the HMI display data format (Property table/Setting value...etc.) is correct.
- 6) When using broadcast function, please check if device is available. This is because the broadcast function can be activated only when the user chooses "write only" device for broadcast station number (only choose setting value/setting constant (button) and then the broadcast function can be used). If choosing other devices, the system will ask you to read back the drive setting value, so please ensure to choose the correct device. If choosing the incorrect devices, a "Controller Station Number Error..." fault message will display on HMI screen.
- 7) Support 82XX frequency inverters and 93XX servo inverters.

**B. Definition of controller Read/Write address**

**Registers (n, m, y are in decimal)**

Register Type	Format	Read/Write Range			Data Length
		Word No.	Bit No.		
			LowByte	HighByte subcode	
Parameter without subcode	CWn	n: 1 ~ 10000	N/A	N/A	Word
	CWn.m	n: 1 ~ 10000	m: 0 ~ 23	N/A	Word
Parameter with subcode	CWn/y	n: 1 ~ 10000	N/A	y:1 ~ 255	Word
	CWn/y.m	n: 1 ~ 10000	m: 0 ~ 23	y:1 ~ 255	Word

Register Type	Format	Read/Write Range			Data Length
		Word No.	Bit No.		
			LowByte	HighByte subcode	
Parameter without subcode	CDn	n: 1 ~ 10000	N/A	N/A	DoubleWord
	CDn.m	n: 1 ~ 10000	m: 0 ~ 23	N/A	DoubleWord
Parameter with subcode	CDn/y	n: 1 ~ 10000	N/A	y:1 ~ 255	DoubleWord
	CDn/y.m	n: 1 ~ 10000	m: 0 ~ 23	y:1 ~ 255	DoubleWord

 **NOTE**

1) m : HMI communication data format

2) The value of m represents the different communication data format:

- If m value is undefined: ASCII hexadecimal format (VH). (4 or 8 numbers.)
- m >= 23 : ASCII hexadecimal format (VH). (4 or 8 numbers.)
- m = 0 ~10 : unsigned, ASCII decimal format (VD).

m represents decimal place, For example:

m=0 → no decimal place

m=1 → one decimal place (tenth)

m=2 → two decimal place (hundredth)

- m = 11 ~20 : signed, ASCII decimal format (VD).

m represents decimal place, For example:

m=11 → one decimal place (tenth)

m=12 → two decimal place (hundredth)

- m = 21 : signed, ASCII decimal format (VD).

without decimal place

- m = 22 : ASCII hexadecimal format (VH). 2 numbers.

when using this format, the write value will be limited within the range of 0~0xFF (low byte).

For example: when entering 0x1234 during communication, the actual write value is 0x34, not 0x1234.

**Contacts (n, b, y are in decimal)**

Register Type	Format	Read/Write Range		
		Word No.	Bit No.	
			LowByte	HighByte subcode
Parameter without subcode	CBn.b	n: 1 ~ 10000	b: 0 ~ 31	N/A
Parameter with subcode	CBn/y.b	n: 1 ~ 10000	b: 0 ~ 31	1 ~ 255

Only VH type parameter can provide Bit read/write function (it is convenient for the user to read/write Bit No. of parameters).

CBn.b, CWn (CWn.m), CDn (CDn.m): read/write address is the same (address n).



- 1) Since the data format of this controller is complicated (a. VS (String format), b. VO (Octet string format data blocks), c. VH (ASCII hexadecimal format)(1, 2, 4 bytes), d. VD (ASCII decimal format)(positive, negative, decimal,...)) and the communication format is not compatible, therefore, it is needed to ensure the HMI communication data format is correct, or an error may occur.
- 2) Registers: only can read/write the data of ASCII hexadecimal format (VH), ASCII decimal format (VD) (i.e. Either VH or VD data format can be set via communication.)

Contacts: only can read/write the data of ASCII hexadecimal format (VH)

HMI display data format (Property table/Setting value...etc.) should also be correct.

Explanation:

- Registers: only can read/write the data of VH, VD. HMI needs to set communication data format (please refer to 4), 5) and 6)). String format (VS), and Octet string format for data blocks (VO) can not be used. If the controller returns the data in VS or VO format, HMI will show “.....Value Is Incorrect” on the screen.
- Contacts: only can read/write the data of ASCII hexadecimal format (VH). Only VH type parameter can provide Bit read/write function. If the controller returns the data in other format, HMI will show “.....Value Is Incorrect” on the screen.
- Do not write the inexistent Bit address, or HMI will show “....Write .... Command Can Not be Executed” on the screen.

For example: CW470/1. The valid value of CW470/1 is within the range of 0 ~ 0xFF. Therefore, Bit 8 ~31 is not existed. Although HMI will show the value of Bit 8 ~31 is 0, the user can not write or set the value.

- The settings of ASCII hexadecimal format (VH) and ASCII decimal format (VD) should be correct. If the VD data is set in VH format in HMI (m value is undefined, or m=22 or 23) or the VH data is set in VD format in HMI (m=0 ~ 21), when HMI write the data, HMI will show “....Write .... Command Can Not be Executed” on the screen or tell the user the write value is incorrect.
- The decimal place of ASCII decimal format (VD) should be set correctly, or the write value will not be correct. The decimal place displayed on HMI should also be correct, or the display value will be incorrect.
- ASCII hexadecimal format (VH), 2 numbers (m = 22). The value is limited to 2 numbers. Using this format the write value will be limited within the range of 0 ~ 0xFF (low byte) automatically.

### 3) Station Number and Broadcast

- The valid station number is from 0 to 99. If exceeds this range, HMI will stop read/write operation and show “Controller Station Number Error ...”on the screen.

- 00 indicates the global broadcasting number (1~99).
- 10, 20, 30, 40, 50, 60, 70, 80, 90 are local broadcasting number.  
The affected ranges are: 11~19, 21~29, 31~39, 41~49, 51~59, 61~69, 71~79, 81~89 and 91~99 respectively. Only choose setting value/setting constant (button), and then the broadcast function can be used. If choosing other devices, the system will be confused while reading back the drive setting value via broadcast function, so please ensure to choose the correct device. If choosing the incorrect devices, a "Controller Station Number Error..." fault message will display on HMI screen.
- Use in LECOM-A/B protocol. 82XX frequency AC drives and 93XX servo drives all use this protocol.

4) Explanation of communication error address

- Registers: display CW n, CWy n, CD n, CDy n in order
- Contacts: display CB n, CByn in order (n: address value)

5) HMI data format explanation

- Some controller parameters are in Word and some are in Double Word. Therefore, there are two kinds of data format: Word ( CWn (CWn.m), CWn/y(CWn/y.m) ) and Double Word ( CDn (CDn.m), CDn/y(CDn/y.m) ).
- Furthermore, regarding to Bit No., HMI only read/write 32Bit (Bit0 ~ Bit31) of parameters in VH format.
- CWn(CWn.m), CDn(CDn.m), or CBn.b: read/write address is the same (address n), but  
When symbol is set to CW, read/write value is the low word of parameters (n) only,  
When symbol is set to CD, read/write value is the Double Word of whole parameters (n),  
When symbol is set to CB, read/write value is the Bit (b) No. of parameters (n).  
(m : HMI communication data format)
- (CWn/y(CWn/y.m), CDn/y(CDn/y.m), CBn/y.b: read/write address, which y subcode is the same(address n), but  
When symbol is set to CW, read/write value is the low word of parameters (n) only,  
When symbol is set to CD, read/write value is the Double Word of whole parameters (n),  
When symbol is set to CB, read/write value is the Bit (b) No. of parameters (n).  
(m : HMI communication data format)
- Actually when using HMI,
  - i) When using devices that the unit is in Word (e.g. numeric devices (numeric value display, numeric value input...)...), the read/write value will be the same no matter the read/write address format is set to CWn or CDn as read/write value is the low word of parameters (n) only.
  - ii) When using devices that the unit is in Double Word (e.g. numeric devices (numeric value display, numeric value input...)...), if the read/write address format is set to CWn, read/write value is coming from the low word of CWn and CWn+1 these two addresses. (The low word of CWn is regarded as "low word" and the low word of CWn+1 is regarded as "high word", and then combining "low word" and "high word" to a Double Word.)



If the read/write address format is set to CDn, read/write value is the whole Double Word of CDn (1 address).

- iii) When using character device (e.g. character display, character input...), if the read/write address format is set to CWn, the read/write value is coming from the low word of CWn, CWn+1, CWn+2, ...every address.

If the read/write address format is set to CDn, read/write value is the whole Double Word of CDn, CDn+1, CDn+2,...every address.

- iv) When using "Multiple Duplicate" function, if the Word and Bit addresses exceed the valid range, the Word and Bit addresses will be set to 0 automatically. Sometime error will occur to remind the user when compiling.
- v) CBn.b, CBn/y.b are added for the user to read and write Bit No. of parameters in VH format more easily.
- vi) Only can read or write 1 parameter for each communication.

**C. Connections (Connector Pinouts)**

Pin 2, 3, 5 are for RS-232 communication. Pin 7, 8 are for RS-485 communication.

**RS-232**

DOP 9 pin D-SUB male (RS-232)	Controller 9 pin D-SUB male (RS-232)	Controller 9 pin D-SUB male (RS-232)
RXD (2) ————— (3) TXD TXD (3) ————— (2) RXD GND (5) ————— (5) GND		 Pin 1 Top View

**RS-485**

DOP 9 pin D-SUB male (RS-485)	Controller 9 pin D-SUB male (RS-485)	Controller 9 pin D-SUB male (RS-485)
D- (1) ————— (7) T/R (A) D- (4) ————— D+ (2) ————— (8) T/R (B) D+ (3) —————		 Pin 1 Top View

**LG Master K120S/200S**[Back to Table](#)**A. HMI factory settings**

Baud rate: 38400, 8, None, 1. (RS-232)

Controller station number: 0. (no PLC station number in protocol, therefore, only 1(HMI) to 1 (PLC) communication is allowed.)

Control area/status area: DW0 / DW10.

**B. Definition of controller Read/Write address****Registers**

Register Type	Format	Word No.	Bit No.	Data Size
WORD_DEVICE_PW	PWn	n: 0 ~ 15	N/A	Word
WORD_DEVICE_MW	MWn	n: 0 ~ 191	N/A	Word
WORD_DEVICE_KW	KWn	n: 0 ~ 31	N/A	Word
WORD_DEVICE_LW	LWn	n: 0 ~ 63	N/A	Word
WORD_DEVICE_FW	FWn	n: 0 ~ 63	N/A	Word
WORD_DEVICE_TW	TWn	n: 0 ~ 255	N/A	Word
WORD_DEVICE_CW	CWn	n: 0 ~ 255	N/A	Word
WORD_DEVICE_DW	DWn	n: 0 ~ 9999	N/A	Word

**Contacts**

Contact type	Format	Word No.	Bit No.
BIT_DEVICE_P	Pnb	n: 0 ~ 15	b: 0 ~ f
BIT_DEVICE_M	Mnb	n: 0 ~ 191	b: 0 ~ f
BIT_DEVICE_K	Kn	n: 0 ~ 31	b: 0 ~ f
BIT_DEVICE_L	Ln	n: 0 ~ 63	b: 0 ~ f
BIT_DEVICE_F	Fnb	n: 0 ~ 63	b: 0 ~ f
BIT_DEVICE_T	Tn	N/A	n: 0 ~ 255
BIT_DEVICE_C	Cn	N/A	n: 0 ~ 255

**C. Connections (Connector Pinouts)**

**RS-232**

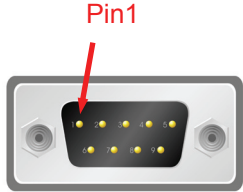
DOP 9 pin D-SUB male (RS-232)	Controller 9 pin D-SUB male (RS-232 for LG K120S/200S)	Controller 9 pin D-SUB male (RS-232 for LG K120S/200S)
RXD (2) ————— (3) TXD TXD (3) ————— (2) RXD GND (5) ————— (5) GND		 <p>Top View</p>

 **NOTE**

- 1) If connecting to Pin 4 (RXD), Pin 7 (TXD) and Pin5 (SG), it indicates that CNet protocol is used (Please refer to the section "[LG Master-K CNET](#)"). 120S/200S protocol and CNet protocol cannot be used simultaneously. The users only can select either 120S/200S protocol or CNet protocol.

## LG Glofa GM6 CNET

[Back to Table](#)

## A. HMI factory settings

Baud rate: 19200, 8, None, 1. (RS-232)

Controller station number: 0.

Control area/status area: %MW0 / %MW10.



- 1) HMI default setting is predefined for CPU Port. If the user want to connect to CNET communication module, the baud rate should be changed to 38400, 8, None, 1. (RS-422 / RS-485).

## B. Definition of controller Read/Write address

## Registers

Register Type	Format	Word No.	Bit No.	Data Size
Input Image	IWb.s.w	w(word):0 ~ 3 s(slot): 0 ~ 7	b(base): 0 ~ 1	Word
Input Image	IDb.s.w	w(word):0 ~ 1 s(slot): 0 ~ 7	b(base): 0 ~ 1	DWord
Output Image	QWb.s.w	w(word):0 ~ 3 s(slot): 0 ~ 7	b(base): 0 ~ 1	Word
Output Image	QDb.s.w	w(word):0 ~ 1 s(slot): 0 ~ 7	b(base): 0 ~ 1	DWord
Internal Memory	MWn	n: 0 ~ 4095	N/A	Word
Internal Memory	MDn	n: 0 ~ 2047	N/A	DWord

## Contacts

Contact type	Format	Word No.	Bit No.
Input Image	IXb.s.n	s(slot): 0 ~ 7	n(bit): 0 ~ 63 b(base): 0 ~ 1
Output Image	QXb.s.n	s(slot): 0 ~ 7	n(bit): 0 ~ 63 b(base): 0 ~ 1
Internal Memory	MXn	N/A	n: 0 ~ 65535

**C. Connections (Connector Pinouts)**

**RS-232**

**via CPU Port**

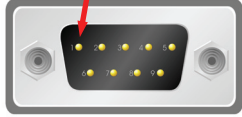
DOP 9 pin D-SUB male (RS-232)	Controller 9 pin D-SUB male (RS-232)	Controller 9 pin D-SUB male (RS-232)
		 <p>Pin1</p> <p>Top View</p>
	<p>RXD (2) ————— (7) TXD</p> <p>TXD (3) ————— (4) RXD</p> <p>GND (5) ————— (5) GND</p>	

**RS-422**

**via G6L-CUEC CNET communication module**

DOP 9 pin D-SUB male (RS-422)	Controller Cable Connector (RS-422)
	<p>RXD+ (2) ————— SDA</p> <p>RXD- (1) ————— SDB</p> <p>TXD- (4) ————— RDB</p> <p>TXD+ (3) ————— RDA</p> <p>GND (5) ————— SG</p>

## LG Master-K CNET

[Back to Table](#)

## A. HMI factory settings

Baud rate: 38400, 8, None, 1. (RS-422)

Controller station number: 0.

Control area/status area: DW0 / DW10.



- 1) HMI default setting is predefined for G6L-CUEC CNET communication module.

## B. Definition of controller Read/Write address

## Registers

Register Type	Format	Word No.	Bit No.	Data Size
I/O Relay	PWn	n: 0 ~ 31	N/A	Word
Auxiliary Relay	MWn	n: 0 ~ 191	N/A	Word
Keep Relay	KWn	n: 0 ~ 31	N/A	Word
Link Relay	LWn	n: 0 ~ 63	N/A	Word
Special Relay	FWn	n: 0 ~ 63	N/A	Word (Read Only)
Timer Elapsed Value	TWn	n: 0 ~ 255	N/A	Word
Counter Elapsed Value	CWn	n: 0 ~ 255	N/A	Word
Data Register	DWn	n: 0 ~ 9999	N/A	Word

## Contacts

Contact type	Format	Word No.	Bit No.
I/O Relay	PXnb	n: 0 ~ 31	b: 0 ~ F
Auxiliary Relay	MXnb	n: 0 ~ 191	b: 0 ~ F
Keep Relay	KXnb	n: 0 ~ 31	b: 0 ~ F
Link Relay	LXnb	n: 0 ~ 63	b: 0 ~ F
Special Relay	FXnb	n: 0 ~ 63	b: 0 ~ F
Timer Contact Relay	TXb	N/A	b: 0 ~ 255
Counter Contact Relay	CXb	N/A	b: 0 ~ 255

**C. Connections (Connector Pinouts)**

**RS-422**

**via G6L-CUEC CNET communication module**

DOP 9 pin D-SUB male (RS-422)	Controller Cable Connector (RS-422)
RXD+ (2)	SDA
RXD- (1)	SDB
TXD- (4)	RDB
TXD+ (3)	RDA
GND (5)	SG

**RS-232**

**via LG-120S PLC (Master K)**

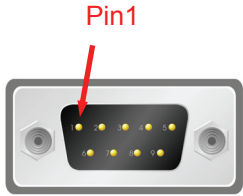
DOP 9 pin D-SUB male (RS-232)	Controller 9 pin D-SUB male (RS-232)	Controller 9 pin D-SUB male (RS-232)
RXD (2)	(7) TXD	 <p>Pin1</p> <p>Top View</p>
TXD (3)	(4) RXD	
GND (5)	(5) GND	

## LG XGT CNET

[Back to Table](#)

## A. HMI factory settings

Baud rate: 9600, 8, None, 1.

Controller station number: 0.

Control area/status area: DW0 / DW10.



- 
- 1) HMI default setting is predefined for XGL-CH2A CNET communication module.

## B. Definition of controller Read/Write address

## Registers

Register Type	Format	Word No.	Bit No.	Data Size
I/O Relay	PWn	n: 0 ~ 2047	N/A	Word
Auxiliary Relay	MWn	n: 0 ~ 2047	N/A	Word
Keep Relay	KWn	n: 0 ~ 2047	N/A	Word
Link Relay	LWn	n: 0 ~ 11263	N/A	Word
Special Relay	FWn	n: 0 ~ 2047	N/A	Word (Read Only)
Timer Elapsed Value	TWn	n: 0 ~ 2047	N/A	Word
Counter Elapsed Value	CWn	n: 0 ~ 2047	N/A	Word
Data Register	DWn	n: 0 ~ 32767	N/A	Word

## Contacts

Contact type	Format	Word No.	Bit No.
I/O Relay	PXnb	n: 0 ~ 2047	b: 0 ~ F
Auxiliary Relay	MXnb	n: 0 ~ 2047	b: 0 ~ F
Keep Relay	KXnb	n: 0 ~ 2047	b: 0 ~ F
Link Relay	LXnb	n: 0 ~ 11263	b: 0 ~ F
Special Relay	FXnb	n: 0 ~ 2047	b: 0 ~ F
Timer Contact Relay	TXb	N/A	b: 0 ~ 2047
Counter Contact Relay	CXb	N/A	b: 0 ~ 2047
Data Relay	DXn.b	n: 0 ~ 32767	b: 0 ~ F



C. Connections (Connector Pinouts)

**RS-422**

**via XGL-CH2A CNET communication module (Channel 2)**

DOP 9 pin D-SUB male (RS-422)	Controller Cable Connector (RS-422)
RXD+ (2)	TX+
RXD- (1)	TX-
TXD- (4)	RX-
TXD+ (3)	RX+
GND (5)	SG

**RS-232**

**via XGL-CH2A CNET communication module (Channel 1)**

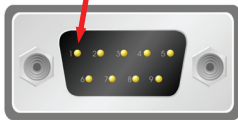
DOP 9 pin D-SUB male (RS-232)	Controller 9 pin D-SUB male (RS-232)	Controller 9 pin D-SUB male (RS-232)
RXD (2)	(3) TXD	 Pin1 Top View
TXD (3)	(2) RXD	
GND (5)	(5) GND	

## LIYAN LYPLC EX

[Back to Table](#)**A. HMI factory settings**

Baud rate: 9600, 7, EVEN, 1.

Controller station number: 0.

Control area/status area: D0 / D10.

**B. Definition of controller Read/Write address****Registers**

Register Type	Format	Read/Write Range		Data length
		Word No.	Bit No.	
Auxiliary Relay	Mn	n: 0 ~ 3064	N/A	Byte
Special Auxiliary Relay	Mn	n: 8000 ~ 8248	N/A	Byte
Status Relay	Sn	n: 0 ~ 992	N/A	Byte
Input Relay	Xn	n: 0 ~ 360(octal)	N/A	Byte
Output Relay	Yn	n: 0 ~ 360(octal)	N/A	Byte
Timer PV	Tn	n: 0 ~ 255	N/A	Word
16-bit Counter PV	Cn	n: 0 ~ 199	N/A	Word
32-bit Counter PV	Cn	n: 200 ~ 255	N/A	Double Word
Data Register	Dn	n: 0 ~ 7999	N/A	Word
Special Data Register	Dn	n: 8000 ~ 8255	N/A	Word

Auxiliary Relay / Special Auxiliary Relay / Status Relay / Input Relay / Output Relay: Address must be the multiple of 8.

**Contacts**

Contact type	Format	Read/Write Range	
		Word No.	Bit No.
Auxiliary Relay	Mn	N/A	n: 0 ~ 3071
Special Auxiliary Relay	Mn	N/A	n: 8000 ~ 8255
Status Relay	Sn	N/A	n: 0 ~ 999
Input Relay	Xn	N/A	n: 0 ~ 377(octal)
Output Relay	Yn	N/A	n: 0 ~ 377(octal)
Timer Flag	Tn	N/A	n: 0 ~ 255
Counter Flag	Cn	N/A	n: 0 ~ 255

C. Connections (Connector Pinouts)

**RS-232**

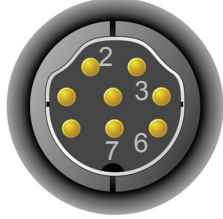
DOP 9 pin D-SUB male (RS-232)	Controller 8 pin Mini DIN male (RS-232)	Controller 8 pin Mini DIN male (RS-232)
<p>RXD (2) ————— (2) TXD</p> <p>TXD (3) ————— (7) RXD</p> <p>GND (5) ————— (3) GND</p> <p style="margin-left: 150px;">└── (6) GND</p>		 <p style="text-align: center;">Top View</p>

**M2i Master**[Back to Table](#)**A. HMI factory settings**

Baud rate: 38400, 8, None, 1.

Controller station number: 1.

Control area/status area: SB0 / SB10.

**B. Definition of controller Read/Write address****Registers**

Register Type	Format	Read/Write Range		Data length
		<u>Word No.</u>	<u>Bit No.</u>	
Word Address	SBn	n: 0000 ~ FFFF	N/A	Word

**Contacts**

Contact type	Format	Read/Write Range	
		<u>Word No.</u>	<u>Bit No.</u>
Bit Address	SBn.b	n: 0000 ~ FFFF	b: 0 ~ F

## M2i Slave

[Back to Table](#)

## A. HMI factory settings

Baud rate: 38400, 8, None, 1.

Controller station number: 1 (no function)

Control area/status area: SB0 / SB10.

 **NOTE**

- 1) HMI station number is Slave station number. (default setting is 0)
- 2) The relation between M2i communication address and HMI internal registers.

Modbus address		Data definition in HMI
SB0000 ~ SB7FFF	→	\$0 ~ \$32767
SB8000 ~ SB83FF	→	\$M0 ~ \$M1023
SB8400	→	RCPNO
SB8500 ~ SBFFFF	→	RCP0 ~ RCP31487

## B. Definition of controller Read/Write address

## Registers

Register Type	Format	Word No.	Bit No.	Data Size
Word Address	SBn	n: 0000 ~ FFFF	N/A	Word

## Contacts

Contact type	Format	Read/Write Range	
		Word No.	Bit No.
Bit Address	SBn.b	n:0000 ~ FFFF	b: 0 ~ F

## C. Connections (Connector Pinouts):

Please refer to 1.1 Pin Definition of Serial Communication for detail.

## Matsushita FP PLC

[Back to Table](#)

## A. HMI factory settings

Baud rate: 9600, 8, ODD, 1.

Controller station number: 238.

Control area/status area: DT0 / DT10.

## B. Definition of controller Read/Write address

## Registers

Register Type	Format	Read/Write Range		Data length
		Word No.	Bit No.	
Internal Relay Special Internal Relay	WRn	n: 0 ~ 886, 900 ~ 910	N/A	Word
Link Relay	WLn	n: 0 ~ 639	N/A	Word
External Input Relay	WXn	n: 0 ~ 511	N/A	Word
External Output Relay	WYn	n: 0 ~ 511	N/A	Word
Timer/Counter P.V.	EVn	n: 0 ~ 3071	N/A	Word
Timer/Counter S.V.	SVn	n: 0 ~ 3071	N/A	Word
Data Register	DTn	n: 0 ~ 32764	N/A	Word
Link Data Register	LDn	n: 0 ~ 8447	N/A	Word
File Register	FLn	n: 0 ~ 32764	N/A	Word
Special Data Register	DT9_n	n: 0 ~ 511	N/A	Word

- DT9\_0 ~ DT9\_511 are applicable for FP0 T32C, FP2, FP2SH, FP10SH controllers. (Special data registers are all within the range of DT90000 ~ DT9XXXX).
- The actual transmitted address of DT9\_n is 90000 + n (for DT). For example, the actual transmitted address of DT9\_1 is 90001 (for DT), the actual transmitted address of DT9\_2 is 90002 (for DT) and vice versa.

## Contacts

Contact type	Format	Read/Write Range	
		Word No.	Bit No.
Internal Relay Special Internal Relay	Rnb	n: 0 ~ 886 n: 900 ~ 910	b: 0 ~ f b: 0 ~ f
Link Relay	Lnb	n: 0 ~ 639	b: 0 ~ f
External Input Relay	Xnb	n: 0 ~ 511	b: 0 ~ f
External Output Relay	Ynb	n: 0 ~ 511	b: 0 ~ f
Timer Flag Contact	Tn	N/A	n: 0 ~ 3071
Counter Flag Contact	Cn	N/A	n: 0 ~ 3071

➤ Increase the range of read / write address (for FP2SH / FP10SH controllers).

**C. Connections (Connector Pinouts)**

**RS-232**

DOP Series 9 pin D-SUB male (RS-232)	Controller 5 pin Mini DIN male (RS-232 for FP0)	Controller 5 pin Mini DIN male (RS-232 for FP0)
<p>RXD (2) ————— (2) TXD</p> <p>TXD (3) ————— (3) RXD</p> <p>GND (5) ————— (1) SG</p>		 <p>Top View</p>

**RS-232**

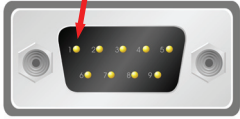
DOP Series 9 pin D-SUB male (RS-232)	Controller 9 pin D-SUB male (RS-232 for FP1)	Controller 9 pin D-SUB male (RS-232 for FP1)
<p>RXD (2) ————— (2) TXD</p> <p>TXD (3) ————— (3) RXD</p> <p>GND (5) ————— (7) GND</p> <p style="margin-left: 150px;">└── (4) RTS</p> <p style="margin-left: 150px;">└── (5) CTS</p>		 <p>Top View</p>

Mirle FAMA SC

[Back to Table](#)

**A. HMI factory settings**

Baud rate: 9600, 7, EVEN, 1.

Controller station number: 0.

Control area/status area: 40100 / 40200.

**B. Definition of controller Read/Write address**

**Registers**

Register Type	Format	Read/Write Range		Data Length
		Word No.	Bit No.	
Output Registers	Wn	n: 40001 ~ 50000	N/A	Word
Input Registers	Wn	n: 30001 ~ 40000	N/A	Word

➤ Input Registers is “read only”.

**Contacts**

Contact type	Format	Read/Write Range	
		Word No.	Bit No.
Discrete Outputs	Bn	N/A	n: 1 ~ 10000
Discrete Inputs	Bn	N/A	n: 10001 ~ 20000

➤ Discrete Inputs is “read only”.

**C. Connections (Connector Pinouts)**

**RS-232**

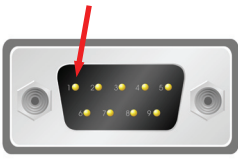
DOP Series 9 pin D-SUB male (RS-232)	Controller 9 pin D-SUB male (RS-232)	Controller 9 pin D-SUB male (RS-232)
RXD (2) ————— (3) TXD TXD (3) ————— (2) RXD GND (5) ————— (5) SG		 <p>Pin1</p> <p>Top View</p>



## Mitsubishi FX/FX2N PLC

[Back to Table](#)

## A. HMI factory settings

Baud rate: 9600, 7, EVEN, 1.

Controller Station number: 0. (no PLC station number in protocol, therefore, only 1(HMI) to 1 (PLC) communication is allowed.)

Control area/status area: D0 / D10.



- 1) If connecting to Mitsubishi FXxN series PLC, the user can use both FX2N and FX series communication protocol.
- 2) If connecting to Mitsubishi FX series PLC, the user can only use FX series communication protocol.
- 3) Some registers of Mitsubishi PLCs are “read only”, however, when you write these “read only” registers, PLCs will not report any communication error to HMI and this will cause HMI errors. Please be aware of this when editing PLC program (this normally occurs when using FX series protocol when connecting to a FXxN series PLC).
- 4) If connecting to Mitsubishi FXxN series PLC, it is recommended for the user to use FX2N protocol.

## B. Definition of controller Read/Write address

## Registers

Register Type	Format	Read/Write Range		Data length
		Word No.	Bit No.	
Auxiliary Relay	Mn	n: 0 ~ 3064	N/A	Byte
Special Auxiliary Relay	Mn	n: 8000 ~ 8248	N/A	Byte
Status Relay	Sn	n: 0 ~ 992	N/A	Byte
Input Relay	Xn	n: 0 ~ 360(octal)	N/A	Byte
Output Relay	Yn	n: 0 ~ 360(octal)	N/A	Byte
Timer PV	Tn	n: 0 ~ 255	N/A	Word
16-bit Counter PV	Cn	n: 0 ~ 199	N/A	Word
32-bit Counter PV	Cn	n: 200 ~ 255	N/A	Double Word
Data Register	Dn	n: 0 ~ 7999	N/A	Word
Special Data Register	Dn	n: 8000 ~ 8255	N/A	Word

- Auxiliary Relay/ Special Auxiliary Relay/ Status Relay/ Input Relay /Output Relay: Address must be the multiple of 8.

**Contacts**

Contact type	Format	Read/Write Range	
		Word No.	Bit No.
Auxiliary Relay	Mn	N/A	n: 0 ~ 3071
Special Auxiliary Relay	Mn	N/A	n: 8000 ~ 8255
Status Relay	Sn	N/A	n: 0 ~ 999
Input Relay	Xn	N/A	n: 0 ~ 377(octal)
Output Relay	Yn	N/A	n: 0 ~ 377(octal)
Timer Flag	Tn	N/A	n: 0 ~ 255
Counter Flag	Cn	N/A	n: 0 ~ 255

**C. Connections (Connector Pinouts)**

**RS-422**

DOP Series 9 pin D-SUB male (RS-422)	Controller 8pin Mini DIN male (RS-422)	Controller 8pin Mini DIN male (RS-422)
<p>RXD+ (2) ————— (7) TXD+</p> <p>RXD- (1) ————— (4) TXD-</p> <p>TXD+ (3) ————— (2) RXD+</p> <p>TXD- (4) ————— (1) RXD-</p> <p>GND (5) ————— (3) SG</p>	 <p>Top View</p>	

**RS-422**

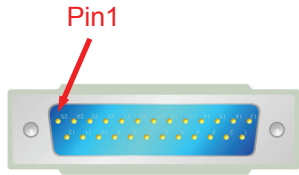
DOP 9 pin D-SUB male (RS-422)	Controller 25 pin D-SUB male (RS-422)	Controller 25 pin D-SUB male (RS-422)
<p>Pin 2 (RXD+) ————— Pin3 SDB (TXD+)</p> <p>Pin 1 (RXD-) ————— Pin16 SDA (TXD-)</p> <p>Pin 4 (TXD-) ————— Pin 15 RDA (RXD-)</p> <p>Pin 3 (TXD+) ————— Pin 2 RDB (RXD+)</p> <p>Pin 7 (RTS+) ————— Pin4 (CTS+)</p> <p>Pin 8 (CTS+) ————— Pin5 (RTS+)</p> <p>Pin 6 (RTS-) ————— Pin 17 (CTS-)</p> <p>Pin 9 (CTS-) ————— Pin 18 (RTS-)</p> <p>Pin 20</p> <p>Pin 21</p>		

## Mitsubishi FX3U PLC

[Back to Table](#)

## A. HMI factory settings

Baud rate: 9600, 7, EVEN, 1.

Controller Station number: 0. (no PLC station number in protocol, therefore, only 1(HMI) to 1 (PLC) communication is allowed.)

Control area/status area: D0 / D10.

## B. Definition of controller Read/Write address

## Registers

Register Type	Format	Read/Write Range		Data length
		Word No.	Bit No.	
Auxiliary Relay	Mn	n: 0 ~ 7679	N/A	Word
Special Auxiliary Relay	Mn	n: 8000 ~ 8511	N/A	Word
Status Relay	Sn	n: 0 ~ 4095	N/A	Word
Input Relay	Xn	n: 0 ~ 377(octal)	N/A	Word
Output Relay	Yn	n: 0 ~ 377(octal)	N/A	Word
Timer PV	Tn	n: 0 ~ 255	N/A	Word
16-bit Counter PV	Cn	n: 0 ~ 199	N/A	Word
32-bit Counter PV	Cn	n: 200 ~ 255	N/A	Double Word
Data Register	Dn	n: 0 ~ 7999	N/A	Word
Special Data Register	Dn	n: 8000 ~ 8511	N/A	Word

- Auxiliary Relay/ Special Auxiliary Relay/ Status Relay/ Input Relay /Output Relay: Address must be the multiple of 16.

## Contacts

Contact type	Format	Read/Write Range	
		Word No.	Bit No.
Auxiliary Relay	Mn	N/A	n: 0 ~ 7679
Special Auxiliary Relay	Mn	N/A	n: 8000 ~ 8511
Status Relay	Sn	N/A	n: 0 ~ 4095
Input Relay	Xn	N/A	n: 0 ~ 377(octal)
Output Relay	Yn	N/A	n: 0 ~ 377(octal)
Timer Flag	Tn	N/A	n: 0 ~ 255
Counter Flag	Cn	N/A	n: 0 ~ 255

C. Connections (Connector Pinouts)

**RS-422**

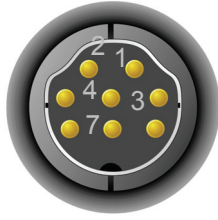
DOP Series 9 pin D-SUB male (RS-422)	Controller 8pin Mini DIN male (RS-422)	Controller 8pin Mini DIN male (RS-422)
<p>RXD+ (2) ————— (7) TXD+</p> <p>RXD- (1) ————— (4) TXD-</p> <p>TXD+ (3) ————— (2) RXD+</p> <p>TXD- (4) ————— (1) RXD-</p> <p>GND (5) ————— (3) SG</p>		 <p>Top View</p>

## Mitsubishi A Series AJ71UC24 Communication Module

[Back to Table](#)**A. HMI factory settings**

Baud rate: 9600, 8, ODD, 1.

Controller Station number: 0.

Control area/status area: D0 / D10.



- 1) This driver utilizes CheckSum.
- 2) Please set "PLC Mode" switch to position 5.
- 3) If OUTPUT Relay (Y) and Special Data Relay (SM) are set to 1, PLC will stop communication and the communication will not recover automatically. PLC will need to be manually reset.

**B. Definition of controller Read/Write address****Registers**

Register Type	Format	Read/Write Range		Data length
		Word No.	Bit No.	
Input	Xn	n: 0 ~ 7FF	N/A	Word (multiple of 16)
Output	Yn	n: 0 ~ 7FF	N/A	Word (multiple of 16)
Link Relay	Bn	n: 0 ~ FFF	N/A	Word (multiple of 16)
Internal Relay	Mn	n: 0 ~ 8191	N/A	Word (multiple of 16)
Special Internal Relay	SMn	n: 9000 ~ 9255	N/A	Word (9000 + multiple of 16)
Latch Relay	Ln	n: 0 ~ 2047	N/A	Word (multiple of 16)
Annunciator	Fn	n: 0 ~ 2047	N/A	Word (multiple of 16)
Timer Value	TNn	n: 0 ~ 999	N/A	Word
Counter Value	CNn	n: 0 ~ 999	N/A	Word
Data Register	Dn	n: 0 ~ 8191	N/A	Word
Special Data Register	SDn	n: 9000 ~ 9255	N/A	Word
File Register	Rn	n: 0 ~ 8191	N/A	Word
Link Register	Wn	n: 0 ~ FFF	N/A	Word

**Contacts**

Contact type	Format	Read/Write Range	
		Word No.	Bit No.
Input	Xn	N/A	n: 0 ~ 7FF
Output	Yn	N/A	n: 0 ~ 7FF
Link Relay	Bn	N/A	n: 0 ~ FFF
Internal Relay	Mn	N/A	n: 0 ~ 8191
Special Internal Relay	SMn	N/A	n: 9000 ~ 9255
Latch Relay	Ln	N/A	n: 0 ~ 2047
Annunciator	Fn	N/A	n: 0 ~ 2047
Timer Contact	TSn	N/A	n: 0 ~ 999
Timer Coil	TCn	N/A	n: 0 ~ 999
Counter Contact	CSn	N/A	n: 0 ~ 999
Counter Coil	CCn	N/A	n: 0 ~ 999

**C. Connections (Connector Pinouts)****RS-422**

DOP 9 pin D-SUB male (RS-422)	Controller Cable Connector (RS-422)
RXD+ (2)	SDA
RXD- (1)	SDB
TXD+ (3)	RDA
TXD- (4)	RDB

**A. HMI factory settings**

Baud rate: 9600, 8, ODD, 1.

Controller Station number: 0. (no PLC station number in protocol, therefore, only 1(HMI) to 1 (PLC) communication is allowed.)

Control area/status area: D0 / D10.



1) This driver supports all Mitsubishi A series CPU port. Mitsubishi A series CPU port can be divided into the following five categories according the used CPU code (used during communication):

- A0J2...
- A1N...
- A1S ( / A2S / A2N ...)
- A3N ( / A1SH / A2SH ...)
- A2A ( / A2AS / A2USH ...)

Delta HMI can support A2USH CPU port (same as A2A, A2AS CPU port.) and A1SH CPU port (same as A3N, A2ASH CPU port.).

2) L and M: The communication address of L is the same as communication address of M.

3) PX and X:

In Mitsubishi A2A PLC, the communication address of PX and X are the same.

In other Mitsubishi A series PLCs, X is from odd address and PX is from even address. That is one place where PX and X differ.

4) X, Y, B, M, SM, L, F, PX ----(Word),

X, Y, B, M, SM, L, F, PX ----(Bit),

When PLC station number is set to 255, only the value of even addresses will be read/written.

When PLC station number is set to other number (not 255), all value of all addresses will be read/written.

5) R address: R address will be different according to the size of File Register responded from PLC.

For example, A2USH:

1K:	3800 ~ 4000H
2K:	3000 ~ 4000H
3K:	2800 ~ 4000H
4K:	2000 ~ 4000H
5K:	4000 ~ 6800H( <b>cy</b> )
6K:	4000 ~ 7000H( <b>cy</b> )

File Register: PLC must be started correctly or the read / write value will be incorrect.

6) Max. read/write registers & relays for communication once

128 Words (256 bytes) Registers

64 Words (128 bytes) Relays

**B. Definition of controller Read/Write address**

**Registers**

Register Type	Format	Read/Write Range		Data length
		Word No.	Bit No.	
Input	Xn	n: 0 ~ 7FF	N/A	Word (multiple of 16)
Output	Yn	n: 0 ~ 7FF	N/A	Word (multiple of 16)
Link Relay	Bn	n: 0 ~ FFF	N/A	Word (multiple of 16)
Internal Relay	Mn	n: 0 ~ 8191	N/A	Word (multiple of 16)
Special Internal Relay	SMn	n: 9000 ~ 9255	N/A	Word (9000 + multiple of 16)
Latch Relay	Ln	n: 0 ~ 8191	N/A	Word (multiple of 16)
Annunciator	Fn	n: 0 ~ 2047	N/A	Word (multiple of 16)
Timer Value	TNn	n: 0 ~ 2047	N/A	Word
Counter Value	CNn	n: 0 ~ 1023	N/A	Word
Data Register	Dn	n: 0 ~ 8191	N/A	Word
Special Data Register	SDn	n: 9000 ~ 9255	N/A	Word
File Register	Rn	n: 0 ~ 8191	N/A	Word
Link Register	Wn	n: 0 ~ FFF	N/A	Word
Input Card Register	PXn	n: 0 ~ 7FF	N/A	Word (multiple of 16)

**Contacts**

Contact type	Format	Read/Write Range	
		Word No.	Bit No.
Input	Xn	N/A	n: 0 ~ 7FF
Output	Yn	N/A	n: 0 ~ 7FF
Link Relay	Bn	N/A	n: 0 ~ FFF
Internal Relay	Mn	N/A	n: 0 ~ 8191
Special Internal Relay	SMn	N/A	n: 9000 ~ 9255
Latch Relay	Ln	N/A	n: 0 ~ 2047
Annunciator	Fn	N/A	n: 0 ~ 2047
Timer Contact	TSn	N/A	n: 0 ~ 2047
Timer Coil	TCn	N/A	n: 0 ~ 2047
Counter Contact	CSn	N/A	n: 0 ~ 1023
Counter Coil	CCn	N/A	n: 0 ~ 1023
Input Card Register	PXn	N/A	n: 0 ~ 7FF



C. Connections (Connector Pinouts)

**RS-422**

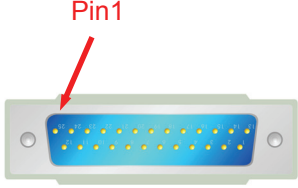
DOP Series 9 pin D-SUB male (RS-422)	Controller 25 pin D-SUB male (RS-422)	Controller 25 pin D-SUB male(RS-422)
Pin 2 (RXD+)	Pin 3 SDB (TXD+)	
Pin 1 (RXD-)	Pin 16 SDA (TXD-)	
Pin 4 (TXD-)	Pin 15 RDA (RXD-)	
Pin 3 (TXD+)	Pin 2 RDB (RXD+)	
Pin 7 (RTS+)	Pin 4 (CTS+)	
Pin 8 (CTS+)	Pin 5 (RTS+)	
Pin 6 (RTS-)	Pin 17 (CTS-)	
Pin 9 (CTS-)	Pin 18 (RTS-)	
	Pin 20	
	Pin 21	

**Explanation**

How to set File Register (R) for Mitsubishi A serial PLC:

1. Startup MELSOFT series GX Developer.
2. Open "Project Data List" windows. ("View" Option)
3. Double click Parameter \ PLC Parameter, and open "Setting" window.
4. Set Memory Capacity \ File Register (0 ~8).
5. Press "End" button on the bottom and complete the setting.
6. Execute OnLineWrite to PLC.
7. Enable the "Parameter \ PLC/Network" and "File register \ Main" option (check the check box next to "Parameter \ PLC/Network" and "File register \ Main").
8. Press "Execute" button.
9. Complete

## Mitsubishi Q Series CPU Port

[Back to Table](#)

## A. HMI factory settings

Baud rate: 19200, 8, ODD, 1.

Controller Station number: 0. (no PLC station number in protocol, therefore, only 1(HMI) to 1 (PLC) communication is allowed.)

Control area/status area: D-0 / D-10.



- 1) Please notice that no PLC station number in protocol, therefore, only 1(HMI) to 1 (PLC) communication is allowed.
- 2) If communication baud rate is not correct, HMI will set PLC baud rate as HMI baud rate automatically. Therefore, do not worry if the baud rate is set incorrectly.
- 3) This driver support Mitsubishi Q00 and Q00J series with password protection models.

## B. Definition of controller Read/Write address

## Registers

Register Type	Format	Read/Write Range		Data length
		Word No.	Bit No.	
Input	X-n	n: 0 ~ 1FFF	N/A	Word (multiple of 16)
Output	Y-n	n: 0 ~ 1FFF	N/A	Word (multiple of 16)
Direct Input	DX-n	n: 0 ~ 1FFF	N/A	Word (multiple of 16)
Direct Output	DY-n	n: 0 ~ 15	N/A	Word (multiple of 16)
Latch Relay	L-n	n: 0 ~ 8191	N/A	Word (multiple of 16)
Annunciator	F-n	n: 0 ~ 2047	N/A	Word (multiple of 16)
Edge Relay	V-n	n: 0 ~ 2047	N/A	Word (multiple of 16)
Step Relay	S-n	n: 0 ~ 8191	N/A	Word (multiple of 16)
Link Relay	B-n	n: 0 ~ 1FFF	N/A	Word (multiple of 16)
Special Link Relay	SB-n	n: 0 ~ 7FF	N/A	Word (multiple of 16)
Internal Relay	M-n	n: 0 ~ 8191	N/A	Word (multiple of 16)
Special Internal Relay	SM-n	n: 0 ~ 2047	N/A	Word (multiple of 16)
Timer Value	TN-n	n: 0 ~ 2047	N/A	Word
Retentive Timer Value	SN-n	n: 0 ~ 2047	N/A	Word
Counter Value	CN-n	n: 0 ~ 1023	N/A	Word
Data Register	D-n	n: 0 ~ 12287	N/A	Word
Special Data Register	SD-n	n: 0 ~ 2047	N/A	Word
Index Register	Z-n	n: 0 ~ 15	N/A	Word
File Register	R-n	n: 0 ~ 32767	N/A	Word

Register Type	Format	Read/Write Range		Data length
		<u>Word No.</u>	<u>Bit No.</u>	
File Register	ZR-n	n: 0 ~ 32767	N/A	Word
Link Register	W-n	n: 0 ~ 1FFF	N/A	Word
Special Link Register	SW-n	n: 0 ~ 7FF	N/A	Word

➤ Xn, Yn, DXn, Bn, SBn, Wn, SWn : n is in hexadecimal.

**Contacts**

Contact type	Format	Read/Write Range	
		<u>Word No.</u>	<u>Bit No.</u>
Input	X-n	N/A	n: 0 ~ 1FFF
Output	Y-n	N/A	n: 0 ~ 1FFF
Direct input	DX-n	N/A	n: 0 ~ 1FFF
Direct output	DY-n	N/A	n: 0 ~ 15
Latch Relay	L-n	N/A	n: 0 ~ 8191
Annunciator	F-n	N/A	n: 0 ~ 2047
Edge Relay	V-n	N/A	n: 0 ~ 2047
Step Relay	S-n	N/A	n: 0 ~ 8191
Link Relay	B-n	N/A	n: 0 ~ 1FFF
Special Link Relay	SB-n	N/A	n: 0 ~ 7FF
Internal Relay	M-n	N/A	n: 0 ~ 8191
Special Internal Relay	SM-n	N/A	n: 0 ~ 2047
Timer Contact	TS-n	N/A	n: 0 ~ 2047
Timer Coil	TC-n	N/A	n: 0 ~ 2047
Retentive timer Contact	SS-n	N/A	n: 0 ~ 2047
Retentive timer Coil	SC-n	N/A	n: 0 ~ 2047
Counter Contact	CS-n	N/A	n: 0 ~ 1023
Counter Coil	CC-n	N/A	n: 0 ~ 1023

➤ Xn, Yn, DXn, Bn, SBn : n is in hexadecimal.

C. Connections (Connector Pinouts)

**RS-232**

DOP 9 pin D-SUB male (RS-232)	Controller 6 pin Mini DIN male (RS-232)	Controller 6 pin Mini DIN male (RS-232)
<p>RXD (2) ————— (2) SD (TXD)</p> <p>TXD (3) ————— (1) RD (RXD)</p> <p>GND (5) ————— (3) GND</p> <p style="margin-left: 100px;">┌ (5) DSR (DR)</p> <p style="margin-left: 100px;">└ (6) DTR (ER)</p>		 <p style="text-align: center;">Top View</p>

## Mitsubishi Q Series Computer Link

[Back to Table](#)

## A. HMI factory settings

Baud rate: 19200, 8, None, 1.

Controller Station number: 0.

Control area/status area: D0 / D10.



- 1) This communication protocol supports Q series RS232 communication module (QJ71C24-R2) and RS422 communication protocol (QJ71C24N).
- 2) Before using this communication protocol, the user needs to set communication module via PC software, GX Developer. For more detailed information regarding the setting method, please refer to Mitsubishi User Manual named "User's Manual (Basic) - Q Corresponding Series Communication Module".

## B. Definition of controller Read/Write address

## Registers

Register Type	Format	Read/Write Range		Data length
		Word No.	Bit No.	
Input	Xn	n: 0-1FFF	N/A	Word (multiple of 16)
Output	Yn	n: 0-1FFF	N/A	Word (multiple of 16)
Internal Relay	Mn	n: 0-8191	N/A	Word (multiple of 16)
Special Internal Relay	Mn	n: 9000-9255	N/A	Word (9000 + multiple of 16)
Link Relay	Bn	n: 0-1FFF	N/A	Word (multiple of 16)
Annunciator	Fn	n: 0-2047	N/A	Word (multiple of 16)
Timer Value	TNn	n: 0-2047	N/A	Word
Counter Value	CNn	n: 0-2047	N/A	Word
Data Register	Dn	n: 0-8191	N/A	Word
Special Data Register	Dn	n: 9000-9255	N/A	Word
Link Register	Wn	n: 0-1FFF	N/A	Word

➤ Xn, Yn, Bn, Wn : n is in hexadecimal.

## Contacts

Contact type	Format	Read/Write Range	
		Word No.	Bit No.
Input	Xn	N/A	n: 0-1FFF
Output	Yn	N/A	n: 0-1FFF
Internal Relay	Mn	N/A	n: 0-8191
Special Internal Relay	Mn	N/A	n: 9000-9255

Contact type	Format	Read/Write Range	
		Word No.	Bit No.
Link Relay	Bn	N/A	n: 0-1FFF
Annunciator	Fn	N/A	n: 0-2047
Timer Contact	TSn	N/A	n: 0-2047
Timer Coil	TCn	N/A	n: 0-2047
Counter Contact	CS-n	N/A	n: 0-2047
Counter Coil	CC-n	N/A	n: 0-2047

➤ Xn, Yn, Bn : n is in hexadecimal.

**C. Connections (Connector Pinouts)**

**RS-232**

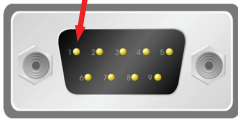
DOP Series 9 pin D-SUB male (RS-232)	Controller 9 pin D-SUB male (RS-232)	Controller 9 pin D-SUB male (RS-232)
RXD (2) —————	(2) TXD	 <p>Top View</p>
TXD (3) —————	(3) RXD	
GND (5) —————	(5) SG	
	(8) RTS	
	(7) CTS	
	(4) DSR (DR)	
	(6) DTR (ER)	

**RS-422**

DOP 9 pin D-SUB male (RS-422)	Controller Cable Connector (RS-422)
RXD+ (2) —————	SDA (1)
RXD- (1) —————	SDB (2)
TXD+ (3) —————	RDA (3)
TXD- (4) —————	RDB (4)
GND (5) —————	SG

## Mitsubishi FX Series PLC via Computer Link

[Back to Table](#)**A. HMI factory settings**

Baud rate: 9600, 7, EVEN, 1.

Controller Station number: 0.

Control area/status area: D0 / D10.



- 1) This communication protocol supports FX series RS485 and RS232 communication module.
- 2) The default setting of this communication protocol is to support RS485 communication module. If the user needs to use RS232 communication module, the user must change the communication setting from RS485 to RS232 manually.
- 3) For more detailed information regarding the communication setting method, please refer to Mitsubishi Communication User Manual named "User's Manual - Data Communication Edition".

**B. Definition of controller Read/Write address****Registers**

Register Type	Format	Read/Write Range		Data length
		Word No.	Bit No.	
Auxiliary Relay	Mn	n: 0-7679	N/A	Word
Special Auxiliary Relay	Mn	n: 8000-8511	N/A	Word
Status Relay	Sn	n: 0-4095	N/A	Word
Input Relay	Xn	n: 0-377(octal)	N/A	Word
Output Relay	Yn	n: 0-377(octal)	N/A	Word
Timer PV	Tn	n: 0-255	N/A	Word
16-bit Counter PV	Cn	n: 0-199	N/A	Word
32-bit Counter PV	Cn	n: 200-255	N/A	Double Word
Data Register	Dn	n: 0-7999	N/A	Word
Special Data Register	Dn	n: 8000-8511	N/A	Word

- Auxiliary Relay / Special Auxiliary Relay / Status Relay / Input Relay / Output Relay: Address must be the multiple of 16.

**Contacts**

Contact type	Format	Read/Write Range	
		Word No.	Bit No.
Auxiliary Relay	Mn	N/A	n: 0-7679
Special Auxiliary Relay	Mn	N/A	n: 8000-8511
Status Relay	Sn	N/A	n: 0-4095

Contact type	Format	Read/Write Range	
		Word No.	Bit No.
Input Relay	Xn	N/A	n: 0-377(octal)
Output Relay	Yn	N/A	n: 0-377(octal)
Timer Flag	Tn	N/A	n: 0-255
Counter Flag	Cn	N/A	n: 0-255

**C. Connections (Connector Pinouts)**

**RS-232**

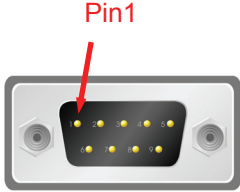
DOP Series 9 pin D-SUB male (RS-232)	Controller 9 pin D-SUB male (RS-232)	Controller 9 pin D-SUB male (RS-232)
<p>RXD (2) ————— TXD (3)</p> <p>TXD (3) ————— RXD (2)</p> <p>GND (5) ————— GND (5)</p>		 <p>Pin1</p> <p>Top View</p>

**RS-485**

DOP 9 pin D-SUB male (RS-485)	Controller Communication Module
<p>D- (1) ————— SDB</p> <p>D- (4) ————— RDB</p> <p>D+ (2) ————— SDA</p> <p>D+ (3) ————— RDA</p> <p>GND (5) ————— GND</p>	



## Mitsubishi J2s Series Servo

[Back to Table](#)

## A. HMI factory settings

Baud rate: 9600, 8, Even, 1 (RS-232).

Controller Station number: 0.

Control area/status area: None / None.

## B. Definition of controller Read/Write address

## Registers

Register Type	Format	Read/Write Range		Data length
		Word No.	Bit No.	
Parameter List (cmd: 05/84) <sup>(NOTE 1)</sup>	Pn	n: 0 – 84	N/A	Double word
Status Display (cmd: 01,8n/NA) <sup>(NOTE 1)</sup>	Sn	n: 0 – E	N/A	Double word
Alarm Number in history (cmd: 33,1n/NA) <sup>(NOTE 1)</sup>	ANn	n: 0 – 5	N/A	Word
Alarm Occurrence time in history (AO) (cmd: 33,2n/NA) <sup>(NOTE 1)</sup>	AOn	n: 0 – 5	N/A	Double word
Current Alarm Number (AC) (cmd: 02/NA) <sup>(NOTE 1)</sup>	ACn	n: 0	N/A	Word
Status Display at alarm occurrence (AS) (cmd: 35,8/NA) <sup>(NOTE 1)</sup>	ASn	n: 0	N/A	Double word
External input pin status (EI) (cmd: 12,40/92,00) <sup>(NOTE 1)</sup>	EIn	n: 0	N/A	Double word
External output pin status (EO) (cmd: 12,C0/92,A0) <sup>(NOTE 1)</sup>	EOn	n: 0	N/A	Double word
Operation mode selection (OP) (cmd: NA/8B,00) <sup>(NOTE 1)</sup>	OPn	n: 0	N/A	Word
Speed for test operation (TSPD) (cmd: NA/A0,10) <sup>(NOTE 1)</sup>	TSPDn	n: 0	N/A	Word
Acceleration/deceleration for test operation (TACC) (cmd: NA/A0,11) <sup>(NOTE 1)</sup>	TACCn	n: 0	N/A	Double word
Distance for test operation (TDIS) (cmd: NA/A0,13) <sup>(NOTE 1)</sup>	TDISn	n: 0	N/A	Double word

## Contacts

Contact type	Format	Read/Write Range	
		Word No.	Bit No.
Status display clear (SRST) (cmd: NA/81,00) <sup>(NOTE 1)</sup>	SRSTb	N/A	b: 0
Alarm history clear (ACLR) (cmd: NA/82,20) <sup>(NOTE 1)</sup>	ACLRb	N/A	b: 0

Contact type	Format	Read/Write Range	
		Word No.	Bit No.
Alarm reset (ARST) (cmd: NA/82,00) <sup>(NOTE 1)</sup>	ARSTb	N/A	b: 0
Turn off the external input signals (DI) (OFDI) (cmd: NA/90,00) <sup>(NOTE 1)</sup>	OFDIb	N/A	b: 0
Changes the external output signals (DO) (CHDO) (cmd: NA/90,03) <sup>(NOTE 1)</sup>	CHDOb	N/A	b: 0
Enable the disabled external input signals (ENDI) (cmd: NA/90,10) <sup>(NOTE 1)</sup>	ENDIb	N/A	b: 0
Enable the disabled external output signals (ENDO) (cmd: NA/90,13) <sup>(NOTE 1)</sup>	ENDOb	N/A	b: 0
Clear the time constant of acceleration in test operation mode (TCLR) (cmd: NA/A0,12) <sup>(NOTE 1)</sup>	TCLRb	N/A	b: 0
Temporary stop of position mode in test operation (TSTP) (cmd: NA/A0,15) <sup>(NOTE 1)</sup>	TSTPb	N/A	b: 0

**C. Connections (Connector Pinouts)**

**RS-232**

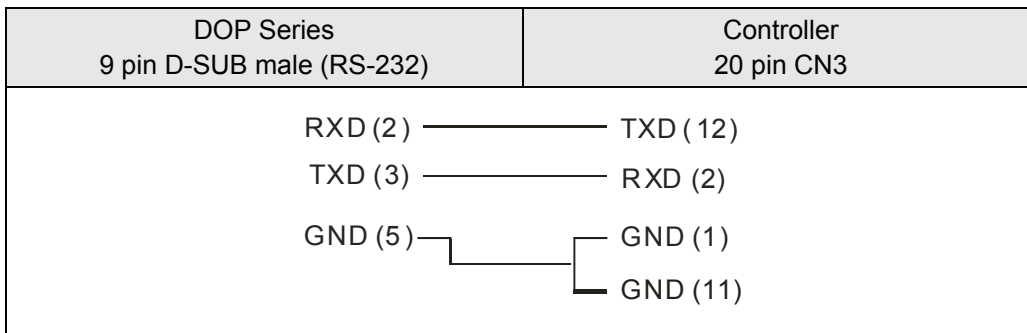

 **NOTE**

1) Read / Write Limit

This communication protocol uses devices to simulate the operation of Servo, so there is a limit for the device to read and write the command. In the column of register type and contact type, the string of characters after “cmd:” indicates the corresponding Servo command that the device will read and write. For example, the string of characters after “cmd:” of the register, Status display is 01,8n/NA. It means that the device can read it but cannot write it. One more example, the string of characters after “cmd:” of the Operation mode selection (OP) is N/A/8B,00. It means that the device can write it but cannot read it.

## MKS BY125 Low Cost Synchrocontroller

[Back to Table](#)

## A. HMI factory settings

Baud rate: 9600, 7, EVEN, 1.

Controller Station number: 11 <sup>(NOTE 1)</sup>.

Control area/status area: None / None.

## B. Definition of controller Read/Write address

## Registers

Register Type	Format	Read/Write Range		Data Length
		<u>Word No.</u>	<u>Bit No.</u>	
Data In Register / Setup Register	Cn	n: 0 ~ 17, 40 ~ 41, 45 ~ 48, 50, 90 ~ 92	N/A	Double Word
Synchronizing (Differential Counter)	SYN_ERRn	n: 0	N/A	Double Word
Integration register	IRn	n: 0	N/A	Double Word
Actual Master speed	MAS_SPDn	n: 0	N/A	Double Word

## Contacts

Contact type	Format	Read/Write Range	
		<u>Word No.</u>	<u>Bit No.</u>
Reset	RSTn	N/A	n: 0
Jog Trim+	JOGTRIM_INCN	N/A	n: 0
Jog Trim-	JOGTRIM_DECN	N/A	n: 0
Activate Data	ACT_DATAn	N/A	n: 0
Store EEPROM	STR_EEPROMn	N/A	n: 0
Index Slave	IND_SLAn	N/A	n: 0
Index Master	IND_MASn	N/A	n: 0

**C. Connections (Connector Pinouts)**

**RS-232**

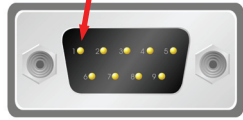
DOP 9 pin D-SUB male (RS-232)	Controller 20 pin CN3	Controller 20 pin CN3
RXD (2) ————— (3) TXD		 <p>Pin1</p> <p>Top View</p>
TXD (3) ————— (2) RXD		
GND (5) ————— (5) SG		

**RS-485**

DOP 9 pin D-SUB male (RS-485)	Controller	Controller
RXD (2) ————— (3) TXD		 <p>Pin1</p> <p>Top View</p>
TXD (3) ————— (2) RXD		
GND (5) ————— (5) SG		

 **NOTE**

- 1) The valid station number is in the range of 11 to 99. However, 20, 30, 40, 50, 60, 70, 80 and 90 cannot be used as they are all broadcast station number.  
 00 for all broadcast  
 10 for the broadcast to 11 ~ 19  
 20 for the broadcast to 21 ~ 29  
 and vise versa.
- 2) Now the broadcast function is not provided, therefore, 20, 30, 40, 50, 60, 70, 80 and 90 cannot be used.
- 3) Only one data (1 Word/ 1 Double Word / 1 Bit) can be read and written for each communication. So, the "Optimize" (Optimization for reading) selection in "Communication" tab in the "Configuration" dialog box in "Options" menu (Options → Configuration → Communication) is cancelled.
- 4) When using RS-232 communication, the user only can use 3 pins (Pin 2, Pin 3 and Pin 5). DO NOT use 5 pins for RS-232 communication. Also, Pin 9 is for +5V. Do not confuse and connect to the wrong pin; otherwise the serious damage may occur.
- 5) The effective addresses of Cn are not consecutive (5 blocks: C0~17, C40~41, C45~C48, C50, C90~C92). When setting the addresses, do not exceed the block range. For example, when using a Numeric Entry or Character Entry element, if the address is C15, the data length only can be 6 Words

(C15, C16, C17). If the data length is out of this range, i.e. occupy other addresses except C0~C17, an error may occur.

- 6) The effective addresses of Cn are not consecutive (5 blocks: C0~17, C40~41, C45~C48, C50, C90~C92). However, when executing duplicate function (Decrease Address), the addresses will be regarded as consecutive addresses. For example, the next address of C90 is C50; the next address of C50 is C48; the next address of C45 is C41; the next address of C40 is C17.
- 7) When all Word address is written, the controllers all response ACK(0x06). But when all Word address is read, the receive value will not change. The user needs to press ACT\_DATA0 again and then the receive value will be updated.

## MKS CT150

[Back to Table](#)**A. HMI factory settings**

Baud rate: 9600, 7, E, 1. (RS-232)

Controller Station number: 11.

Control area/status area: None / None.

**B. Definition of controller Read/Write address****Registers**

Register Type	Format	Read/Write Range	
		Word No.	Bit No.
Data In Register	Cn	n: 0 ~ 25	N/A
Setup Register	Cn	n: 40 ~ 43 45 ~ 50 90 ~ 97	N/A
Error Count	Err_CNT	0	N/A
LV Value	LV_VAL	0	N/A
Printmark Error	PRTMARK_ERR	0	N/A
Batch Counter	BAT_CNT	0	N/A
Waste Counter	WASTE_CNT	0	N/A
Line Speed	LINE_SPD	0	N/A
Actual Cutting Length	ACT_CUT_LEN	0	N/A

**Contacts**

Contact type	Format	Read/Write Range	
		Word No.	Bit No.
Reset	RST	N/A	0
Jog Trim+	JOGTRIM_INC	N/A	0
Jog Trim-	JOGTRIM_DEC	N/A	0
Read PI	READ_PI	N/A	0
Activate Data	ACT_DATA	N/A	0
Store Eeprom	STR_EEPROM	N/A	0
Start/Stop	START_STOP	N/A	0
Reset Mark Counter	RSTMARK_CNT	N/A	0

C. Connections (Connector Pinouts)

**RS-232**

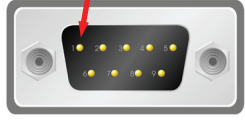
DOP 9 pin D-SUB male (RS-232)	Controller 9 pin D-SUB male (RS-232)	Controller 9 pin D-SUB male (RS-232)
<p>RXD (2) ————— (3) TXD</p> <p>TXD (3) ————— (2) RXD</p> <p>GND (5) ————— (5) SG</p>		<p>Pin1</p>  <p>Top View</p>

## MKS MC700/720 Motion Controller

[Back to Table](#)**A. HMI factory settings**

Baud rate: 9600, 7, EVEN, 1.

Controller Station number: 11 <sup>(NOTE 1)</sup>.

Control area/status area: None / None.

**B. Definition of controller Read/Write address****Registers**

Register Type	Format	Read/Write Range		Data Length
		<u>Word No.</u>	<u>Bit No.</u>	
General Parameters	GPn	n: 0 ~ 31	N/A	Double Word
Parameter Block for Slave 1	PB1_n	n: 0 ~ 31	N/A	Double Word
Parameter Block for Slave 2	PB2_n	n: 0 ~ 31	N/A	Double Word
Parameter Block for Slave 3	PB3_n	n: 0 ~ 31	N/A	Double Word
Parameter Block for Slave 4	PB4_n	n: 0 ~ 31	N/A	Double Word
Process Data	PRODn	n: 0 ~ 31	N/A	Double Word
Communication Settings	CSETn	n: 0 ~ 31	N/A	Double Word
Setup Settings	STUPn	n: 0 ~ 31	N/A	Double Word
Status of Commands and Outputs	S_CO n	n: 0 ~ 4	N/A	Double Word

**Contacts**

Contact type	Format	Read/Write Range	
		<u>Word No.</u>	<u>Bit No.</u>
Commands	CMDb	N/A	b: 0 ~ 31
Outputs	OUTb	N/A	b: 0 ~ 31
Status of Commands and Outputs	S_CO n.b	n: 0 ~ 4	b: 0 ~ 31



C. Connections (Connector Pinouts)

**RS-232**

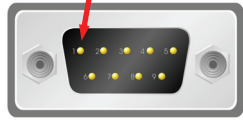
DOP 9 pin D-SUB male (RS-232)	Controller 9 pin D-SUB male (RS-232)	Controller 9 pin D-SUB male (RS-232)
RXD (2) ————— (3) TXD		 <p>Top View</p>
TXD (3) ————— (2) RXD		
GND (5) ————— (5) GND		

**RS-422**

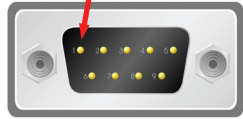
DOP 9 pin D-SUB male (RS-422)	Controller 9 pin D-SUB male (RS-422)	Controller 9 pin D-SUB male (RS-422)
RXD- (1) ————— (7) T-		 <p>Top View</p>
RXD+ (2) ————— (8) T+		
TXD+ (3) ————— (6) R+		
TXD- (4) ————— (1) R-		

**RS-485**

DOP 9 pin D-SUB male (RS-485)	DOP 9 pin D-SUB male (RS-485)	DOP 9 pin D-SUB male (RS-485)
D+ (2) ———— D+ (3) ———— D- (1) ———— D- (4) ————	T+ (8)   T-(7)	 <p>Top View</p>

 **NOTE**

- 1) The valid station number is in the range of 11 to 99. However, 20, 30, 40, 50, 60, 70, 80 and 90 cannot be used as they are all broadcast station number.  
 00 for all broadcast  
 10 for the broadcast to 11 ~ 19  
 20 for the broadcast to 21 ~ 29  
 and vise versa.
- 2) Now the broadcast function is not provided, therefore, 20, 30, 40, 50, 60, 70, 80 and 90 cannot be used.

- 3) Only one data (1 Word/ 1 Double Word / 1 Bit) can be read and written for each communication. So, the “Optimize” (Optimization for reading) selection in “Communication” tab in the “Configuration” dialog box in “Options” menu (Options → Configuration → Communication) is cancelled.
- 4) When using RS-232 communication, the user only can use 3 pins (Pin 2, Pin 3 and Pin 5). DO NOT use 5 pins for RS-232 communication. Also, Pin 9 is for +5V. Do not confuse and connect to the wrong pin; otherwise the serious damage may occur.

## Modbus(Master) --- 984 RTU / ASCII mode

[Back to Table](#)**A. HMI factory settings**

Baud rate: 9600, 7, EVEN, 1. (ASCII)

9600, 8, EVEN, 1. (RTU)

Controller station number: 0.

Control area/status area: W40100 / W40200.

**B. Definition of controller Read/Write address****Registers**

Register Type	Format	Read/Write Range		Data length
		<u>Word No.</u>	<u>Bit No.</u>	
Output Registers	Wn	n: 40001 ~ 50000	N/A	Word
Input Registers	Wn	n: 30001 ~ 40000	N/A	Word

➤ Input Registers is “read only”.

**Contacts**

Contact type	Format	Read/Write Range	
		<u>Word No.</u>	<u>Bit No.</u>
Discrete Outputs	Bn	N/A	n: 1 ~ 10000
Discrete Inputs	Bn	N/A	n: 10001 ~ 20000

➤ Discrete Inputs is “read only”.

**C. Connections (Connector Pinouts)**

Please refer to 1.1 Pin Definition of Serial Communication for detail.

**Modbus Hexadecimal Address (Master) --- RTU / ASCII mode**[Back to Table](#)**A. HMI factory settings**

Baud rate: 9600, 7, EVEN, 1. (ASCII)

9600, 8, EVEN, 1. (RTU)

Controller station number: 0.

Control area/status area: RW-0 / RW-10.

**NOTE**

1) The valid communication address starts from 0 and the format is hexadecimal. So the settable range are 0 to 65535 (i.e. 0 ~ FFFF in hexadecimal format).

2) The difference than “Standard Modbus” communication: (Protocol is the same)

The usage of setting communication address is different.

The range of communication address is different

The “Standard Modbus” communication is in decimal format. The start addresses are 40001, 30001, 1, 10001 and contains 10000 addresses respectively (40001 ~ 50000, 30001 ~ 40000, 1 ~ 10000, 10001 ~ 20000).

The Modbus Hexadecimal Address (Master) is in hexadecimal format. The starting addresses are all from 0 and there is 65536 addressing space (from 0 to FFFF) in each PDU (protocol data unit).

**B. Definition of controller Read/Write address****Registers**

Register Type	Format	Read/Write Range		Data length
		Word No.	Bit No.	
Output Registers	RW-n	n: 0 ~ FFFF	N/A	Word
Input Registers	R-n	n: 0 ~ FFFF	N/A	Word

➤ RW- : can Read and Write.

Converting the address to decimal format and plus 40001, it will immediately become the corresponding “Standard Modbus” communication address.

➤ R- (Input Registers) : Read only.

Converting the address to decimal format and plus 30001, it will immediately become the corresponding “Standard Modbus” communication address.

**Contacts**

Contact type	Format	Read/Write Range	
		Word No.	Bit No.
Discrete Outputs	RWB-n	N/A	n: 0 ~ FFFF
Discrete Inputs	RB-n	N/A	n: 0 ~ FFFF

- RWB- : can Read and Write.

Converting the address to decimal format and plus 1, it will immediately become the corresponding "Standard Modbus" communication address.

- RB- (Discrete Inputs) : Read only.

Converting the address to decimal format and plus 10001, it will immediately become the corresponding "Standard Modbus" communication address.

 **NOTE**

- 
- 1) Only first 10000 addresses can be converted to "Standard Modbus" communication address.

**Modbus nW (Master) --- RTU / ASCII mode**[Back to Table](#)**A. HMI factory settings**

Baud rate: 9600, 7, EVEN, 1. (ASCII)

9600, 8, EVEN, 1. (RTU)

Controller station number: 1.

Control area/status area: W40100 / W40200.



- 1) This driver can read consecutive communication address on the screen via one Modbus command to improve the communication efficiency. For example, if there are 6 devices on the screen, and read the data of the addresses W40100, W40101, W40102, W40200, W40201, W40300. It will read three times. It will read W40100 3 Words at the first time, read W40200 2 Words at the second time and read W40300 1 Word at the third time.
- 2) Ensure to check the box next to "Optimize" (Optimization for reading) selection in "Communication" tab in the "Configuration" dialog box in "Options" menu (Options → Configuration → Communication). If "Optimize" selection is unchecked, do not select "Data Length Limit".

**B. Definition of controller Read/Write address****Registers**

Register Type	Format	Read/Write Range		Data length
		<u>Word No.</u>	<u>Bit No.</u>	
Output Registers	Wn	n: 40001 ~ 50000	N/A	Word
Input Registers	Wn	n: 30001 ~ 40000	N/A	Word

➤ Input Registers is "read only".

**Contacts**

Contact type	Format	Read/Write Range	
		<u>Word No.</u>	<u>Bit No.</u>
Discrete Outputs	Bn	N/A	n: 1 ~ 10000
Discrete Inputs	Bn	N/A	n: 10001 ~ 20000

➤ Discrete Inputs is "read only".

**C. Connections (Connector Pinouts)**

Please refer to 1.1 Pin Definition of Serial Communication for detail.

## Modbus (Slave) --- RTU / ASCII mode

[Back to Table](#)

## A. HMI factory settings

Baud rate: 9600, 7, EVEN, 1. (ASCII)

9600, 8, EVEN, 1. (RTU)

Controller station number: 0. (Station number is not used in the protocol.)

Control area/status area: W40100 / 40200.



- 1) HMI station number is Slave station number. (default setting is 0)
- 2) The relation between Modbus address and HMI internal registers.

Modbus address		Data definition in HMI	
W40001 ~ W41024	→	\$0 ~ \$1023	Internal register
W42001 ~ W43024	→	\$M0 ~ \$M1023	Non-volatile internal register
W44001	→	RCPNO	Receipt number register
W45001 ~ ...	→	RCP0 ~ RCPn	Receipt register
B00001 ~ B01024	→	\$2000.0 ~ \$2063.15	Internal register (Bit)
B01025 ~ B02048	→	\$M200.0 ~ \$M263.15	Non-volatile internal register (Bit)

## B. Definition of controller Read/Write address

## Registers

Register Type	Format	Read/Write Range		Data length
		<u>Word No.</u>	<u>Bit No.</u>	
Output Registers	Wn	n: 40001 ~ 50000	N/A	Word

## Contacts

Contact type	Format	Read/Write Range	
		<u>Word No.</u>	<u>Bit No.</u>
Discrete Outputs	Bn	N/A	n: 1 ~ 2048

## C. Connections (Connector Pinouts)

Please refer to 1.1 Pin Definition of Serial Communication for detail.

**CrossReference Table (Inter Memory of Delta HMI and Modbus Reference Address)**

Inter Memory of Delta HMI	Modbus Reference Address	Supporting Modbus Function	Address of Function
\$0	40001	03H, 06H, 10H	0000H
\$1	40002	03H, 06H, 10H	0001H
.			
.			
.			
\$1023	41024	03H, 06H, 10H	03FFH

\$M0	42001	03H, 06H, 10H	07D0H
\$M1	42002	03H, 06H, 10H	07D1H
.			
.			
.			
\$M1023	43024	03H, 06H, 10H	0BCFH

RCPNO	44001	03H, 06H	0FA0H
-------	-------	----------	-------

RCP0	45001	03H, 06H, 10H	1388H
RCP1	45002	03H, 06H, 10H	1389H
.			
.			
.			

\$2000.0	00001	01H, 05H, 0FH	0000H
\$2000.1	00002	01H, 05H, 0FH	0001H
.			
.			
.			
\$2000.15	00016	01H, 05H, 0FH	000FH
\$2001.0	00017	01H, 05H, 0FH	0010H
.			
.			
.			
\$2063.0	01009	01H, 05H, 0FH	03F0H
.			
.			
.			
\$2063.15	01024	01H, 05H, 0FH	03FFH

\$M200.0	01025	01H, 05H, 0FH	0400H
----------	-------	---------------	-------



Inter Memory of Delta HMI	Modbus Reference Address	Supporting Modbus Function	Address of Function
\$M200.1	01026	01H, 05H, 0FH	0401H
.			
.			
\$M200.15	01040	01H, 05H, 0FH	040FH
\$M201.0	01041	01H, 05H, 0FH	0410H
.			
.			
\$M263.0	02033	01H, 05H, 0FH	07F0H
.			
.			
\$M263.15	02048	01H, 05H, 0FH	07FFH

For example:

- Read internal memory **\$100** of Delta HMI (HMI station number: 1)  
: 01 **03 00 64** 00 01 97 CR LF  
Write the value of **1000** into internal memory **\$100** of Delta HMI (HMI station number: 1)  
: 01 **06 00 64 03 E8 AA** CR LF
- Read internal memory **\$M100** of Delta HMI (HMI station number: 1)  
: 01 **03 08 34** 00 01 BF CR LF  
Write the value of **888** into internal memory **\$M100** of Delta HMI (HMI station number: 1)  
: 01 **06 08 34 03 78 42** CR LF
- Read internal memory **\$2000.15** of Delta HMI (HMI station number: 1)  
: 01 **01 00 0F** 00 01 EE CR LF  
Set internal memory **\$2000.15** of Delta HMI to **ON** (HMI station number: 1)  
: 01 **05 00 0F FF 00** EC CR LF  
Set internal memory **\$2000.15** of Delta HMI to **OFF** (HMI station number: 1)  
: 01 **05 00 0F 00 00** EB CR LF
- Read internal memory **\$M201.0** of Delta HMI (HMI station number: 1)  
: 01 **01 04 10** 00 01 E9 CR LF  
Set internal memory **\$M201.0** of Delta HMI to **ON** (HMI station number: 1)  
: 01 **05 04 10 FF 00** E7 CR LF  
Set internal memory **\$M201.0** of Delta HMI to **OFF** (HMI station number: 1)  
: 01 **05 04 10 00 00** E6 CR LF

**Modicon TSX Micro (Uni-Telway)**[Back to Table](#)**A. HMI factory settings**

Baud rate: 9600, 8, ODD, 1.

Controller station number: 2.

Control area/status area: %MW0 / %MW10.



- 1) HMI station needs to be adjusted to 1 ~ 8.
- 2) PLC station and HMI station can be the same.
- 3) The internal memory and relative parameters in PLC should be set properly first. Otherwise, it cannot communicate except %S.

**B. Definition of controller Read/Write address****Registers**

Register Type	Format	Word No.	Bit No.	Data Size
WORD_DEVICE_ Internal	%MWn	n: 0 ~ 65534	N/A	Word
WORD_DEVICE_ System	%SWn	n: 0 ~ 127	N/A	Word
WORD_DEVICE_ Input	%KWn	n: 0 ~ 65534	N/A	Word

- %KWn is “read only”.

**Contacts**

Contact type	Format	Word No.	Bit No.
BIT_DEVICE_ Internal	%Mn:b	n:0 ~ 65534	b:0 ~ 15
BIT_DEVICE_ System	%Sn	-	n:0 ~ 127
BIT_DEVICE_ Internal1	%Mn	-	n:0 ~ 65534

- %Mn: b is Bit address that corresponds to WORD\_DEVICE\_ Internal (%MWn).
- %Mn is PLC internal relay address.
- The read/write range of WORD\_DEVICE\_ Internal / BIT\_DEVICE\_ Internal depends on PLC used memory.

C. Connections (Connector Pinouts)

**RS-232**

It needs to use specific cable of Modicon Uni-Telway. (RS-232) --- TSX PCX 1031

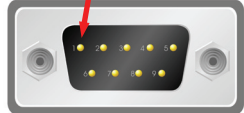
DOP 9 pin D-SUB male (RS-232)	Controller 9 pin D-SUB male (RS-232)	Controller 9 pin D-SUB male (RS-232)
		 <p>Pin1</p> <p>Top View</p>
RXD (2) ————— (2) SD TXD (3) ————— (3) RD GND (5) ————— (5) SG		

**RS-485**

DOP 9 pin D-SUB male (RS-485)	Controller 8 pin Mini DIN male (RS-485)	Controller 8 pin Mini DIN male (RS-485)
		 <p>Top View</p>
RXD+ (2) ———— (1) D+ TXD+ (3) ———— RXD- (1) ———— (2) D- TXD- (4) ————		

**Modicon TSX Micro (Modbus RTU)**

[Back to Table](#)

**A. HMI factory settings**

Baud rate: 9600, 8, ODD, 1.

Controller station number: 2.

Control area/status area: %MW0 / %MW10.



- 1) HMI must select Modbus (Master) --- 984 RTU as the communication mode.
- 2) The communication mode of PLC should be switched to Modbus Slave by using PL7 software.

**B. Connections (Connector Pinouts)**

**RS-485**

DOP 9 pin D-SUB male (RS-485)	Controller 8 pin Mini DIN male (RS-485)	Controller 8 pin Mini DIN male (RS-485)
<p>RXD+ (2) } TXD+ (3) } ———— (1) D+</p> <p>RXD- (1) } TXD- (4) } ———— (2) D-</p> <p>                  } (5)                   } (7)</p>		 <p>Top View</p>

**Modicon TWIDO**

**[Back to Table](#)**

Its function is the same as [Modbus \(Master\) --- 984 RTU](#).

**Moeller PLC**

[Back to Table](#)

**A. HMI factory settings**

Baud rate: 9600, 8, NONE, 1(RS-232).

Controller Station number: 2.

Control area/status area: MW0/MW10.

**B. Definition of controller Read/Write address**

**Registers**

Register Type	Format	Read/Write Range		Data Length
		Word No.	Bit No.	
Marker MW	MWn	n: 0-32766	N/A	Byte
Diagnostic Status DSW	DSWn	n: 0-0	N/A	Byte
Process Status PSW	PSWn	n: 0-0	N/A	Byte
Diagnostic Counter DC	DCn	n: 0-15	N/A	Word

**Contacts**

Contact type	Format	Read/Write Range	
		Word No.	Bit No.
Marker M	Mn.b	n: 0-32766	b: 0-7
Diagnostic Status DS	DSn.b	n: 0-1	b: 0-7
Process Status PS	PSn.b	n: 0-1	b: 0-7

**C. Connections (Connector Pinouts)**

**RS-232**

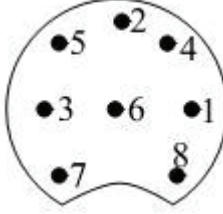
DOP 9 pin D-SUB male (RS-232)	Controller 9 pin D-SUB male (RS-232)	Controller 9 pin D-SUB male (RS-232)
		 <p>Top View</p>
	RXD (2) ————— 5	
	TXD (3) ————— 2	
	GND (5) ————— 3	



1) Communication Setting

The read and write range of register Marker (Device MW) of PS4 Series must be set via PC software or PLC program before connecting to HMI; otherwise, the communication error may occur. The setting range of Marker (Device MW) of PS3 Series is fixed between 0 and 2172 but the address 126 cannot be used.

2) Device MW

Device MW is an even address, but Device M is not.

**A. HMI factory settings**

Baud rate: 9600, 8, ODD, 2.

Controller station number: 1. (valid station number: 0 ~ 99)

Control area/status area: None.

 **NOTE**

- 
- 1) The valid station number is in the range of 0 to 99. If the station number is out of this range, it will subtracted 100 from itself automatically until the station number is in the valid range.

**B. Definition of controller Read/Write address****Registers**

Register Type	Format	Word No.	Bit No.	Data Size
WORD_DEVICE_RRegister	RW-n	n: 0 ~ 3999	N/A	Word
WORD_DEVICE_RRegister	RW-n	n: 8000 ~ 9999	N/A	Word
WORD_DEVICE_DStatus	XW-n	n: 0 ~ 8	N/A	Word
WORD_DEVICE_DStatus	DW-n	n: 0 ~ 129	N/A	Word
WORD_DEVICE_RRegister	RD-n	n: 0-3999	N/A	Double Word
WORD_DEVICE_RRegister	RD-n	n: 8000-9999	N/A	Double Word
WORD_DEVICE_DStatus	DD-n	n: 0-129	N/A	Double Word

 **NOTE**

---

In order for DOP series HMI to be compatible with this controller, DOP series HMI provides various types of data. Please refer to the following description:

- 1) RW-n, RD-n, RB-nb all have corresponding relation (just the data format is different). They all refer to the same address n.
- DW-n, DD-n both have corresponding relation (just the data format is different). They all refer to the same address n.
- XW-n, XB-nb both have corresponding relation (just the data format is different). They all refer to the same address n.
- (In the above format name, the second alphabet represents the data format, W represents Word, D represents Double Word and B represents Bit)
- 2) The data size of RW-n, DW-n is defined as Word in DOP series HMI and each data address is regarded as an individual Word address. The data order uses "Little Endian" architecture which means that the low word of the number is stored in memory at the lowest address, and the high word at the highest address. (such as Intel processors (those used in PC's) use "Little Endian" byte order)



For example, if setting the starting address as RW900 and the data size is Double Word, the read/write value will be a Double Word which contains RW900(low word) and RW901(high word).

In actual application case, if the user sets the data size of RW-n, DW-n as Word, there is no data order reverse problem. However, if the user sets the data size of RW-n, DW-n as Double Word, as this controller use "Big Endian" architecture which means that the high word of the number is stored in memory at the lowest address, and the low word at the highest address (such as Motorola processors (those used in Mac's) use "Big Endian" byte order), a data order reverse problem will occur.

- 3) The data size of RD-n, DD-n is defined as Double Word in DOP series HMI and every two data addresses is regarded as an individual Double Word address. The data order use "Big Endian" architecture (see the meaning above).

For example, if setting the starting address as RD900 and the data size is Double Word, the read/write value will be a Double Word which contains RW900(high word) and RW901(low word).

In actual application case, if the users set the data size of RD-n, DD-n as Double Word, there is no data order reverse problem and the data display on HMI and the controller will be the same. However, if the users set the data size of RD-n, DD-n as Word, only the low word will display and the high word will be set to 0 automatically. For example, if setting the starting address as RD900 and the data size is Word, only the value of RD901(low word) will display. If the write value is 100 at this time, DOP series HMI will set the value of RD901(high word) to 0 and write the value 100 into RD901(low word).

- 4) X-nb and DW-n both have corresponding relation ----- Read DW-n, Write X-nb

DW-0	—	X-0b, (b=0~F)
DW-1	—	X-1b, (b=0~F)
DW-2	—	X-2b, (b=0~F)
DW-4	—	X-3b, (b=0~F)
DW-104	—	X-4b, (b=0~F)
DW-105	—	X-5b, (b=0~F)
DW-106	—	X-6b, (b=0~F)
DW-107	—	X-7b, (b=0~F)
DW-108	—	X-8b, (b=0~F)

- 5) DW-n, DD-n are "read only". If the users write any value into them, HMI will show error message "Command Can Not be Executed...." on the screen.

**Contacts**

Contact type	Format	Word No.	Bit No.
BIT_DEVICE_ RRegister	RB-nb	n: 0 ~ 3999	b:0 ~ F
BIT_DEVICE_ RRegister	RB-nb	n: 8000 ~ 9999	b:0 ~ F
BIT_DEVICE_ BitControl	XB-nb	n:0 ~ 8	b:0 ~ F

C. Connections (Connector Pinouts)

**RS-422**

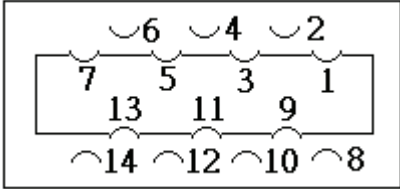
DOP 9 pin D-SUB male (RS-422)	Controller 14 pin special male (RS-422)	Controller 14 pin special male (RS-422)
RXD- (1) ————— RXD+ (2) ————— TXD+ (3) ————— TXD- (4) ————— GND (5) —————	(9) TXD (B) (2) TXD (A) (4) RXD (A) (11) RXD (B) (14) GND	Cable (PLC side (J1), male).  <p style="text-align: center;">Top View</p>

Omron C Series PLC

[Back to Table](#)

**A. HMI factory settings**

Baud rate: 9600, 7, EVEN, 2.

Controller station number: 0.

Control area/status area: DM0 / DM10.

- This driver can support OMRON C/CPM series PLC simultaneously.

**B. Definition of controller Read/Write address**

**Registers**

Register Type	Format	Read/Write Range		Data length
		Word No.	Bit No.	
IR area	IRn	n: 0 ~ 511	N/A	Word
HR area	HRn	n: 0 ~ 99	N/A	Word
AR area	ARn	n: 0 ~ 27	N/A	Word
LR area	LRn	n: 0 ~ 63	N/A	Word
TC area	TCn	n: 0 ~ 511	N/A	Word
DM area	DMn	n: 0 ~ 6655	N/A	Word

**Contacts**

Contact type	Format	Read/Write Range	
		Word No.	Bit No.
IR area	IRnb	n: 0 ~ 511	b: 00 ~ 15
HR area	HRnb	n: 0 ~ 99	b: 00 ~ 15
AR area	ARnb	n: 0 ~ 27	b: 00 ~ 15
LR area	LRnb	n: 0 ~ 63	b: 00 ~ 15
TC area	TCn	N/A	n: 0 ~ 511

**C. Connections (Connector Pinouts)**

**RS-232**

**1:1 Host Link via RS-232C converter**

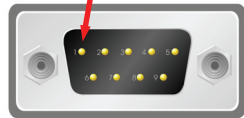
DOP Series 9 pin D-SUB male (RS-232)	Controller 9 pin D-SUB male (RS-232)	Controller 9 pin D-SUB male (RS-232)
RXD (2)	(2) TXD	 <p>Pin1</p> <p>Top View</p>
TXD (3)	(3) RXD	
GND (5)	(9) SG	
	(4) RS	
	(5) CS	

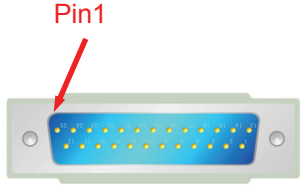
DOP 9 pin D-SUB male (RS-432)	Controller 25 pin D-SUB male (RS-432)	Controller 25 pin D-SUB male (RS-432)
<p>RXD (2) ————— (2) TXD</p> <p>TXD (3) ————— (3) RXD</p> <p>GND (5) ————— (7) SG</p> <p>                                  (4) RS</p> <p>                                  (5) CS</p>		

**RS-422**

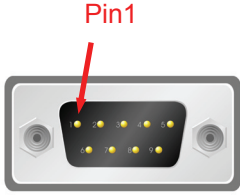
DOP 9 pin D-SUB male (RS-422)	Controller 9 pin D-SUB male (RS-422)	Controller 9 pin D-SUB male (RS-422)
<p>RXD- (1) ————— (9)TXD-</p> <p>RXD+ (2) ————— (5)TXD+</p> <p>TXD+ (3) ————— (1)RXD+</p> <p>TXD- (4) ————— (6)RXD-</p>		 <p>Top View</p>

## Omron CJ1/CS1 Series PLC

[Back to Table](#)

## A. HMI factory settings

Baud rate: 9600, 7, EVEN, 2. (RS-232)

Controller station number: 0.

Control area/status area: D0 / D10.

- This driver can support OMRON CS/CJ/CP1/CQM/CV/CVM series PLC simultaneously.



The meaning of Communication Error Message:

## 1) Word Device:

The Device Name and Address Value will display. For example, if using CIO, H, A, D, E, T, C, W, EM, IR, DR, TK, it will show CIO<sub>n</sub>, H<sub>n</sub>, A<sub>n</sub>, D<sub>n</sub>, Em.<sub>n</sub>, T<sub>n</sub>, C<sub>n</sub>, W<sub>n</sub>, EM<sub>n</sub>, IR<sub>n</sub>, DR<sub>n</sub>, TK<sub>n</sub> respectively. “n” is the Address Value.

## 2) Bit Device:

The Device Name and Word Address Value will display, but the Bit Address Value will not. For example, if using CIO, H, A, D, E, T, C, W, EM, IR, DR, TK, it will show CIOB<sub>n</sub>, HB<sub>n</sub>, AB<sub>n</sub>, DB<sub>n</sub>, EBm.<sub>n</sub>, TB<sub>n</sub>, CB<sub>n</sub>, WB<sub>n</sub>, EMB<sub>n</sub>, IRB<sub>n</sub>, DRB<sub>n</sub>, TKB<sub>n</sub> respectively. “n” is the Word Address Value.

## B. Definition of controller Read/Write address

## Registers

Register Type	Format	Read/Write Range		Data length
		<u>Word No.</u>	<u>Bit No.</u>	
CIO area	CIO <sub>n</sub>	n: 0 ~ 9999	N/A	Word
Hold area	H <sub>n</sub>	n: 0 ~ 999	N/A	Word
Auxiliary area	A <sub>n</sub>	n: 0 ~ 999	N/A	Word
DM area	D <sub>n</sub>	n: 0 ~ 65535	N/A	Word
EM area	Em. <sub>n</sub>	M: 0 ~ 12 (bank no.) n: 0 ~ 65535	N/A	Word
Timer PVs	T <sub>n</sub>	n: 0 ~ 9999	N/A	Word
Counter PVs	C <sub>n</sub>	n: 0 ~ 9999	N/A	Word
Work area	W <sub>n</sub>	n: 0 ~ 999	N/A	Word
EM Current Bank area	EM <sub>n</sub>	n: 0 ~ 65535	N/A	Word
Index Register	IR <sub>n</sub>	n: 0 ~ 99	N/A	Double Word
DR area	DR <sub>n</sub>	n: 0 ~ 99	N/A	Word
TK area	TK <sub>n</sub>	n: 0 ~ 1022 (Even No.)	N/A	Byte

➤ CJ1M Models: An: A0-A477 is “read only”.

## Contacts

Contact type	Format	Read/Write Range	
		Word No.	Bit No.
CIO area	CIOBnbb	n: 0 ~ 9999	bb: 00 ~ 15
Hold area	HBnbb	n: 0 ~ 999	bb: 00 ~ 15
Auxiliary area	ABnbb	n: 0 ~ 999	bb: 00 ~ 15
DM area	DBnbb	n: 0 ~ 65535	bb: 00 ~ 15
EM area	EBm.nbb	n: 0 ~ 65535 m: 0 ~ 12 (bank no.)	bb: 00 ~ 15
Timer area	TBn	N/A	n: 0 ~ 9999
Counter area	CBn	N/A	n: 0 ~ 9999
Work area	WBnbb	n: 0 ~ 999	bb: 00 ~ 15
EM Current Bank area	EMBnbb	n: 0 ~ 65535	bb: 00 ~ 15
Index Register	IRBnbb	n: 0 ~ 99	bb: 00 ~ 31
DR area	DRBnbb	n: 0 ~ 99	bb: 00 ~ 15
TK area	TKBnbb	n: 0 ~ 1022 (Even No.)	bb: 00 ~ 15

### NOTE

- 1) The following address cannot be written:
  - IRn and DRn: It is not valid if the users write them. HMI will not show any error message if the write operation is done.
  - An and Abnbb: Some range of An and Abnbb (Auxiliary area) is “read only”.
  - TKn / TKBnbb / TBn / CBn / EMBnbb / IRBnbb / DRBnbb: Writing these addresses is not allowed. If the write operation is done, the error will occur and display the error message “Command Can Not be Executed...” on the screen of HMI.
- 2) The unit of IR address is “Double Word”.
- 3) The unit of TK address is “Byte” and it should be even number.

C. Connections (Connector Pinouts)

**RS-232**

**CJ1M CPU module**

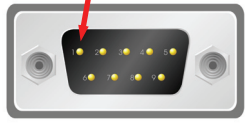
DOP Series 9 pin D-SUB male (RS-232)	Controller 9 pin D-SUB male (RS-232)	Controller 9 pin D-SUB male (RS-232)
RXD (2) ————— (2) TXD		 <p>Pin1</p> <p>Top View</p>
TXD (3) ————— (3) RXD		
GND (5) ————— (9) SG		
	(4) RS	
	(5) CS	

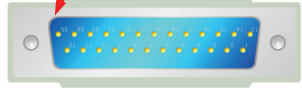
DOP 9 pin D-SUB male (RS-432)	Controller 25 pin D-SUB male (RS-432)	Controller 25 pin D-SUB male (RS-432)
RXD (2) ————— (2) TXD		 <p>Pin1</p>
TXD (3) ————— (3) RXD		
GND (5) ————— (7) SG		
	(4) RS	
	(5) CS	

**RS-422**

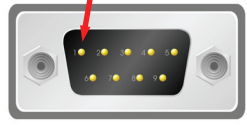
DOP 9 pin D-SUB male (RS-422)	Controller 9 pin D-SUB male (RS-422)	Controller 9 pin D-SUB male (RS-422)
RXD- (1) ————— (9)TXD-		 <p>Pin1</p> <p>Top View</p>
RXD+ (2) ————— (5)TXD+		
TXD+ (3) ————— (1)RXD+		
TXD- (4) ————— (6)RXD-		

**Omron TPM1A PLC**

**[Back to Table](#)**

Its function is the same as [Omron C Series PLC](#).



## Siemens S7 200 PLC

[Back to Table](#)**A. HMI factory settings**

Baud rate: 9600, 8, EVEN, 1.

Controller station number: 2.

Control area/status area: VW0 / VW10.

**B. Definition of controller Read/Write address****Register**

Register Type	Format	Read/Write Range	
		Word No.	Bit No.
Timer	Tn	n: 0 ~ 255	N/A
Analog Input Word	AIWn	n: 0 ~ 30	N/A
Counter	Cn	n: 0 ~ 255	N/A
Analog Output Word	AQWn	n: 0 ~ 30	N/A
Input Image	IWn	n: 0 ~ 14	N/A
Input Image	IDn	n: 0 ~ 12	N/A
Output Image	QWn	n: 0 ~ 14	N/A
Output Image	QDn	n: 0 ~ 12	N/A
Special Bits	SMWn	n: 0 ~ 199	N/A
Special Bits	SMDn	n: 0 ~ 197	N/A
Internal Bits	MWn	n: 0 ~ 98	N/A
Internal Bits	MDn	n: 0 ~ 96	N/A
Data Area	VWn (DBWn)	n: 0 ~ 9998 (n: 0 ~ 9998)	N/A
Data Area	VDn	n: 0 ~ 9996	N/A
Special S	SWn	n: 0 ~ 99	N/A
Special S	SDn	n: 0 ~ 97	N/A

**Contacts**

Contact type	Format	Read/Write Range	
		Word No.	Bit No.
Timer Bit	Tn	N/A	n: 0 ~ 255
Counter Bit	Cn	N/A	n: 0 ~ 255
Input Image	In.b	n: 0 ~ 15	b: 0 ~ 7
Output Image	Qn.b	n: 0 ~ 15	b: 0 ~ 7
Special Bit	SMn.b	n: 0 ~ 200	b: 0 ~ 7
Internal Bit	Mn.b	n: 0 ~ 99	b: 0 ~ 7
Data Area Bit	Vn.b	n: 0 ~ 9999	b: 0 ~ 7

Contact type	Format	Read/Write Range	
		Word No.	Bit No.
Special S Bit	Sn.b	n: 0 ~ 100	b: 0 ~ 7

**C. Connections (Connector Pinouts)**

**RS-232**

**via RS-232 / PPI Multi-Master Cable (Connecting DOP series HMI and PPI cable)**

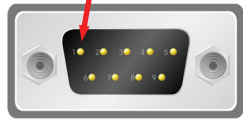
DOP Series 9 pin D-SUB male (RS-232)	Controller 9 pin D-SUB male (RS-232)	Controller 9 pin D-SUB male (RS-232)
<p>RXD (2) ————— (2) RD</p> <p>TXD (3) ————— (3) TD</p> <p>GND (5) ————— (5) GND</p>	 <p>Top View</p>	

**RS-485**

**via PLC Program Port (RS-485)**

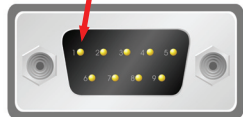
DOP Series 9 pin D-SUB male (RS-485)	Controller 9 pin D-SUB male (RS-485)	Controller 9 pin D-SUB male (RS-485)
<p>RXD+ (2) ———— (3) TXD/RXD+</p> <p>TXD+ (3) ———— (3) TXD/RXD+</p> <p>RXD- (1) ———— (8) TXD/RXD-</p> <p>TXD- (4) ———— (8) TXD/RXD-</p> <p>GND (5) ————— (5) SG</p>	 <p>Top View</p>	

## Siemens S7 300 PLC (with PC Adapter)

[Back to Table](#)

## A. HMI factory settings

Baud rate: 38400, 8, ODD, 1. (RS-232).

Controller station number: 2.

(Communication via PC adapter, PLC station will not be used, therefore, only 1(HMI) to 1 (PLC) communication is allowed.)

Control area/status area: DBW0 / DBW20.

 **NOTE**

1) PLC DB memory (DBm.DBWn, DBm.DBDn, DBm.DBXn.b) must be open so that HMI can read/write.

2) The reason for using PC adapter:

When communicating via PC adapter, it is profibus with **187.5 K** baudrate at PLC side. Therefore, the network structure is faster and steadier.

When HMI communicates with PLC without PC adapter directly, the protocol will be complicated and it needs to lower PLC baud rate to 19200 due to HMI baudrate limit.

3) Baud rate setting

- It needs to set PLC baud rate to 187.5 K and higher. (it cannot use 19.2K)
- It needs to set baud rate of two sides when using PC Adapter
  - i) "PLC side": It needs to set same baudrate as PLC side (as previous item it needs to set PLC baud rate to 187.5 K and higher and cannot use 19.2K)
  - ii) "HMI side": it can select 38.4K or 19.2K by using switch on the cable. (only these two choices)
  - iii) HMI baud rate: it needs to set the baud rate of HMI side of PC adapter as previous item to 38.4K or 19.2K) (protocol setting is still 8, ODD, 1)
  - iv) There is no setting for PLC station and HMI station, so it won't have the communication problem with error station setting.
  - v) PC Adapter :  
The power LED will be lit once connect to PLC. (power supply of PC adapter is from PLC)  
If communication is OK, the communication LED will be blink. Otherwise, it will be dark.

## B. Definition of controller Read/Write address

## Register

Register Type	Format	Read/Write Range	
		Word No.	Bit No.
Input Image	IWn	n: 0 ~ 65534	N/A
Input Image	IDn	n: 0 ~ 65532	N/A

Register Type	Format	Read/Write Range	
		Word No.	Bit No.
Output Image	QWn	n: 0 ~ 65534	N/A
Output Image	QDn	n: 0 ~ 65532	N/A
Internal Bits	MWn	n: 0 ~ 65534	N/A
Internal Bits	MDn	n: 0 ~ 65532	N/A
Data Area	DBm.DBWn	n: 0 ~ 65534	m: 1 ~ 255
	DBm.DBDn	n: 0 ~ 65532	m: 1 ~ 255
Data Area (DB10)	DBWn	n: 0 ~ 65534	N/A
	DBDn	n: 0 ~ 65532	N/A
	VWn	n: 0 ~ 65534	N/A
	VDn	n: 0 ~ 65532	N/A
Timer	Tn	n: 0-65535	N/A
Counter	Cn	n: 0-65535	N/A

 **NOTE**

- The valid digit number of the value for the T(Timer) and C(Counter) is 3-digits only. Therefore, please enter a 3-digit number. If entering a number that exceeds 3 digits, only the first 3 digits are valid (decimal format). The other digits of the value for the T(Timer) will be replaced as 0 and the other digits of the value for the C(Counter) will be abandoned. For example, assume that the users enter the value "12345", the actual write value for the T(Timer) will be "12300" and the actual write value for the C(Counter) will be "123".

### Contacts

Contact type	Format	Read/Write Range	
		Word No.	Bit No.
Input Image	In.b	n: 0 ~ 65535	b: 0 ~ 7
Output Image	Qn.b	n: 0 ~ 65535	b: 0 ~ 7
Internal Bit	Mn.b	n: 0 ~ 65535	b: 0 ~ 7
Data Area Bit	DBm.DBXn.b	n: 0 ~ 65535	b: 0 ~ 7 m = 1 ~ 255
Data Area Bit (10 DB)	DBXn.b	n: 0 ~ 65535	b: 0 ~ 7
	Vn.b	n: 0 ~ 65535	b: 0 ~ 7

 **NOTE**

- For all contacts when performing "Multiple Duplicate" function:
  - If it exceeds 65535 when increasing, it will be regarded as 0.
  - If it is less than 0, it will be regarded as 655XX.

C. Connections (Connector Pinouts)

**RS-232**

**HMI connects to PC Adaptor**

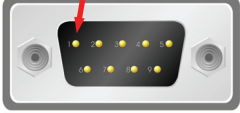
DOP 9 pin D-SUB male	Controller 9 pin D-SUB female	Controller
RXD (2)	————— (3) TXD	 <p style="text-align: center;">Top View</p>
TXD (3)	————— (2) RXD	
GND (5)	————— (5) GND	
RTS (7)	————— (8) CTS	
CTS (8)	————— (7) RTS	

## Siemens S7 300 PLC (without PC Adaptor)

[Back to Table](#)

## A. HMI factory settings

Baud rate: 19200, 8, EVEN, 1. (RS-485).

Controller station number: 2.

Control area/status area: DBW0 / DBW20.

 **NOTE**

- 
- 1) Please notice that only 1(HMI) to 1 (PLC) communication is allowed.
  - 2) PLC baud rate should be changed to **19200**. (8, EVEN, 1.).
  - 3) **DB** must be open, otherwise the related addresses can not be read and write.  
(The related addresses are: DB.DBW, DB.DBD, DBW, DBD, VW, VD, DB.DBX, DBX, V)
  - 4) HMI station must be set to 0 ~ 15. If it is out of this range, it will be changed to 15 automatically. PLC station number must be set to 0 ~ 15.
  - 5) The communication cable is the same as S7 200 series (RS-485).
  - 6) If not connecting to communication cable after 5 seconds, HMI will show error message on the screen. If connecting to communication cable, it is needed to power on HMI again, and then the communication can be found.
  - 7) After power in connected to HMI, HMI must accept the notification from PLC and then connection will be established. The first time connection will take more time, but in normal condition, it should be connected in 5 seconds.
  - 8) This protocol is a token ring communication protocol (HMI needs to communicate with PLC for many times for completing 1 command.) so the response of HMI will be slower (compared with other brands of PLCs when the baud rate setting is set to the same value). The communication speed of S7 300 PLC (without PC Adaptor) is usually slower than the other controllers, but it is the same as the communication speed of S7 300 PLC (with PC Adaptor).
  - 9) When connecting to S7 300 PLC, the communication error may occur occasionally. The user can adjust the HMI communication response time via Extra function which can be found by clicking Option > Configuration > Communication.

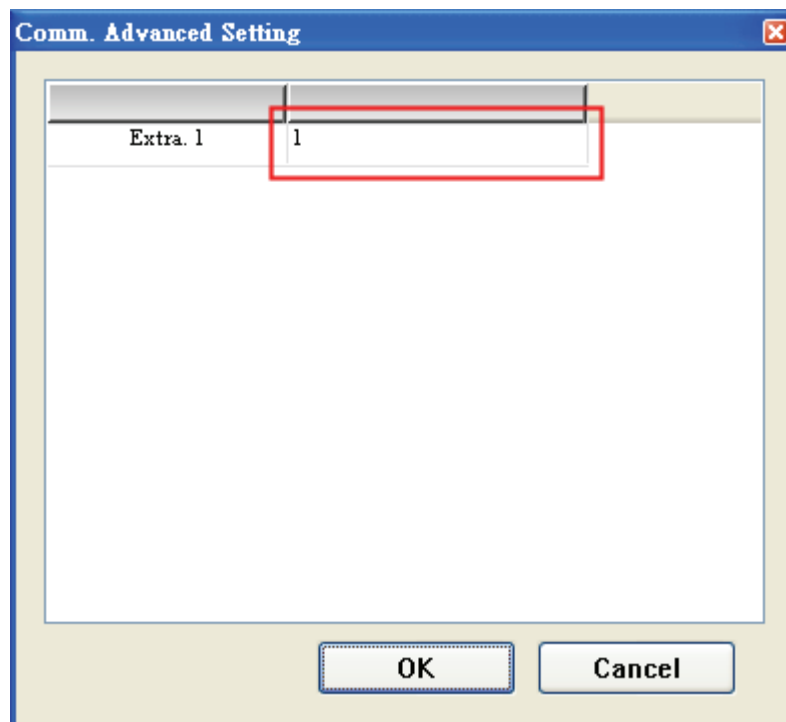
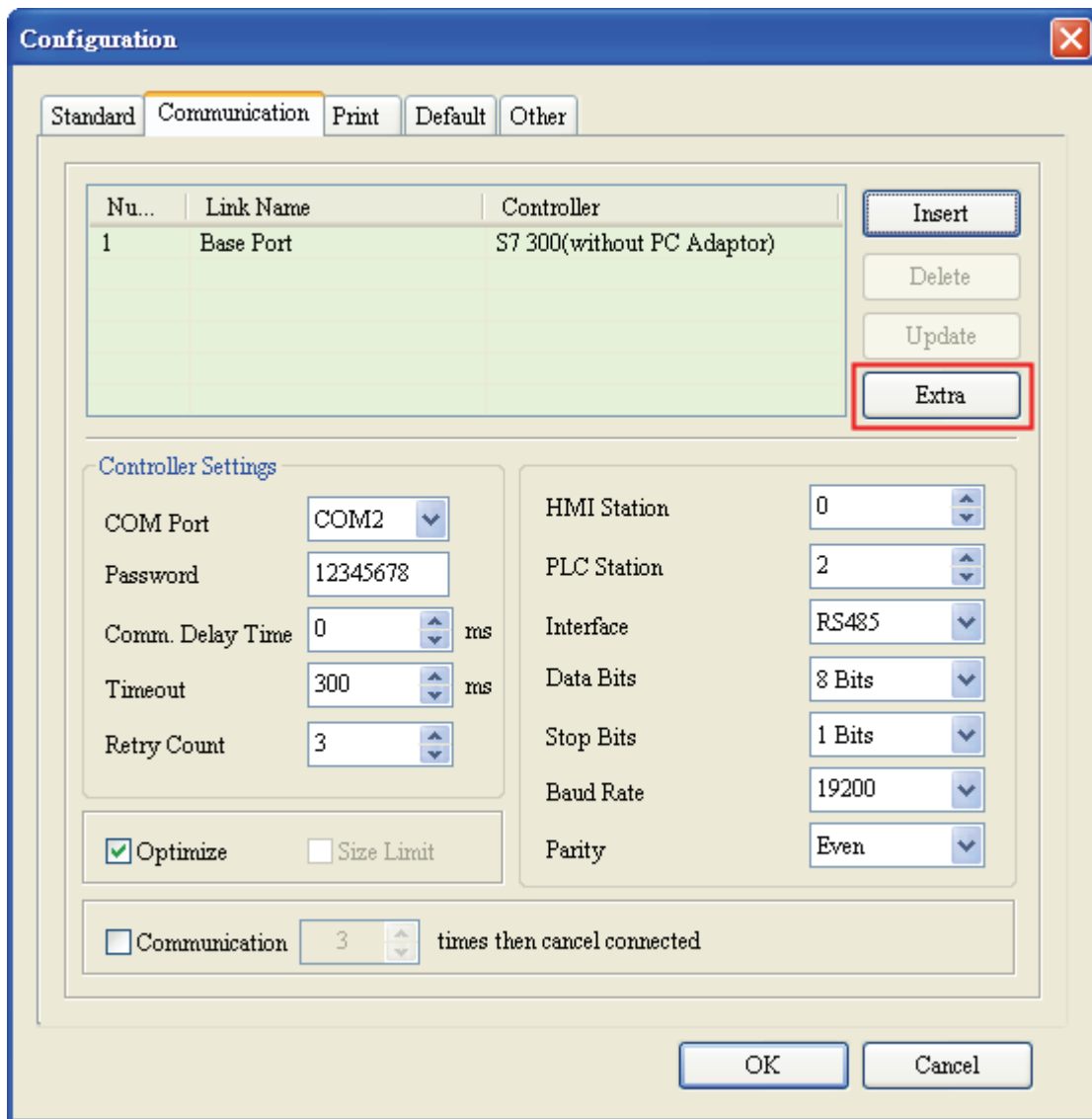

How many COM ports are connected to S7 300 PLC, how may items can be set.

## B. Definition of controller Read/Write address

### Register

Register Type	Format	Read/Write Range	
		Word No.	Bit No.
Input Image	IWn	n: 0 ~ 65534	N/A
Input Image	IDn	n: 0 ~ 65532	N/A
Output Image	QWn	n: 0 ~ 65534	N/A
Output Image	QDn	n: 0 ~ 65532	N/A
Internal Bits	MWn	n: 0 ~ 65534	N/A
Internal Bits	MDn	n: 0 ~ 65532	N/A
Data Area	DBm.DBWn	n: 0 ~ 65534	m: 1 ~ 255 (Note 1)
	DBm.DBDn	n: 0 ~ 65532	m: 1 ~ 255 (Note 1)
Data Area (DB10)	DBWn	n: 0 ~ 65534	N/A
	DBDn	n: 0 ~ 65532	N/A
	VWn	n: 0 ~ 65534	N/A
	VDn	n: 0 ~ 65532	N/A
Timer	Tn	n: 0 ~ 65535	N/A
Counter	Cn	n: 0 ~ 65535	N/A

### NOTE

- 1) High Byte of Bit No.
- The valid digit number of the value for the T(Timer) and C(Counter) is 3-digits only. Therefore, please enter a 3-digit number. If entering a number that exceeds 3 digits, only the first 3 digits are valid (decimal format). The other digits of the value for the T(Timer) will be replaced as 0 and the other digits of the value for the C(Counter) will be abandoned. For example, assume that the users enter the value "12345", the actual write value for the T(Timer) will be "12300" and the actual write value for the C(Counter) will be "123".

### Contacts

Contact type	Format	Read/Write Range	
		Word No.	Bit No.
Input Image	In.b	n: 0 ~ 65535	b: 0 ~ 7 (Note 2)
Output Image	Qn.b	n: 0 ~ 65535	b: 0 ~ 7 (Note 2)
Internal Bit	Mn.b	n: 0 ~ 65535	b: 0 ~ 7 (Note 2)
Data Area Bit	DBm.DBXn.b	n: 0 ~ 65535	b: 0 ~ 7 (Note 2) m = 1 ~ 255 (Note 3)
Data Area Bit (DB 10)	DBXn.b	n: 0 ~ 65535	b: 0 ~ 7 (Note 2)
	Vn.b	n: 0 ~ 65535	b: 0 ~ 7 (Note 2)



 **NOTE**

- 2) Low Byte of Bit No.
- 3) High Byte of Bit No.
- 4) For all timers, counters and contacts when performing “Multiple Duplicate” function:
  - If it exceeds 65535 when increasing, it will be regarded as 0.
  - If it is less than 0, it will be regarded as 655XX.

**C. Connections (Connector Pinouts)**

The communication cable is the same as S7 200 series (RS-485). Please refer to the Connections of S7 200 series (RS-485).

**RS-485**

**via PLC MPI Port (RS-485)**

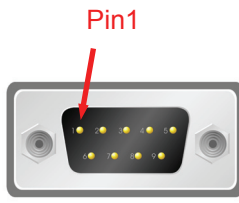
DOP 9 pin D-SUB male (RS-485)	Controller 9 pin D-SUB male (RS-485)	Controller 9 pin D-SUB male (RS-485)
RXD+ (2) ———— TXD+ (3) ———— RXD- (1) ———— TXD- (4) ———— GND (5) ————	(3)TXD/RXD+ (8)TXD/RXD- (5)SG	 <p style="text-align: center;">Top View</p>

## Taian TP02 PLC

[Back to Table](#)**A. HMI factory settings**

Baud rate: 19200, 7, None, 1.

Controller station number: 1.

Control area/status area: V1 / V10.

**B. Definition of controller Read/Write address****Registers**

Register Type	Format	Read/Write Range		Data length
		<u>Word No.</u>	<u>Bit No.</u>	
WORD_DEVICE_X	Xn	n: 1 ~ 384	N/A	Word
WORD_DEVICE_Y	Yn	n: 1 ~ 384	N/A	Word
WORD_DEVICE_C	Cn	n: 1 ~ 2048	N/A	Word
WORD_DEVICE_V	Vn	n: 1 ~ 1024	N/A	Word
WORD_DEVICE_D	Dn	n: 1 ~ 2048	N/A	Word
WORD_DEVICE_WS	WSn	n: 1 ~ 128	N/A	Word
WORD_DEVICE_WC	WCn	n: 1 ~ 912	N/A	Word

- WORD\_DEVICE\_X / WORD\_DEVICE\_Y / WORD\_DEVICE\_C: Address must be 1 or the multiple of 16+1.

**Contacts**

Contact type	Format	Read/Write Range	
		<u>Word No.</u>	<u>Bit No.</u>
BIT_DEVICE_X	Xn	N/A	n: 1 ~ 384
BIT_DEVICE_Y	Yn	N/A	n: 1 ~ 384
BIT_DEVICE_C	Cn	N/A	n: 1 ~ 2048
BIT_DEVICE_SC	SCn	N/A	n: 1 ~ 128

- BIT\_DEVICE\_SC: Only 1 Bit can be transferred for each read command.

C. Connections (Connector Pinouts)

**RS-422**

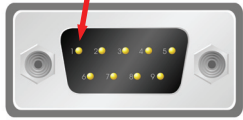
DOP 9 pin D-SUB male (RS-422)	Controller 9 pin D-SUB male (RS-422)	Controller 9 pin D-SUB male (RS-422)
RXD+ (2) ————— (3) TXD+ RXD- (1) ————— (8) TXD- TXD+ (3) ————— (2) RXD+ TXD- (4) ————— (7) RXD-		 <p style="text-align: center;">Top View</p>

**RS-485**

DOP 9 pin D-SUB male (RS-232)	Controller RS-485 (T/R+, T/R-)
RXD+ (2) TXD+ (3)	T/R+
RXD- (1) TXD- (4)	T/R-

## Vigor M Series

[Back to Table](#)

## A. HMI factory settings

Baud rate: 19200, 7, EVEN, 1.

Controller station number: 0.

Control area/status area: D0 / D10.



- 1) Controller station number: 0 for PROGRAMMER PORT; 1 for COM PORT
- 2) VB series also can use this driver.

## B. Definition of controller Read/Write address

## Registers

Register Type	Format	Read/Write Range		Data length
		Word No.	Bit No.	
Input Relay	Xn	n: 0 ~ 770 (Octal)	N/A	Word (multiple of 8)
Output Relay	Yn	n: 0 ~ 770 (Octal)	N/A	Word (multiple of 8)
Auxiliary Relay	Mn	n: 0 ~ 5112	N/A	Word (multiple of 8)
Special Relay	Mn	n: 9000 ~ 9248	N/A	Word (9000 + multiple of 8)
Step Relay	Sn	n: 0 ~ 992	N/A	Word (multiple of 8)
Timer Present Value	Tn	n: 0 ~ 255	N/A	Word
16-bit Counter Present Value	Cn	n: 0 ~ 199	N/A	Word
32-bit Counter Present Value	Cn	n: 200 ~ 255	N/A	Word
Data Register	Dn	n: 0 ~ 8191	N/A	Word
Special Data Register	Dn	n: 9000 ~ 9248	N/A	Word

## Contacts

Contact type	Format	Read/Write range	
		Word No.	Bit No.
Input Relay	Xn	N/A	n: 0 ~ 777(Octal)
Output Relay	Yn	N/A	n: 0 ~ 777(Octal)
Auxiliary Relay	Mn	N/A	n: 0 ~ 5119
Special Relay	Mn	N/A	n: 9000 ~ 9255
Step Relay	Sn	N/A	n: 0 ~ 999
Timer Contact	Tn	N/A	n: 0 ~ 255
Counter Contact	Cn	N/A	n: 0 ~ 255
Timer Coil	TCn	N/A	n: 0 ~ 255
Counter Coil	CCn	N/A	n: 0 ~ 255

C. Connections (Connector Pinouts)

**RS-232**

**(PROGRAMMER PORT)**

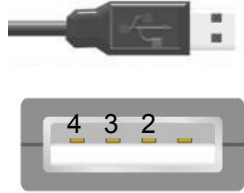
DOP 9 pin D-SUB male(RS-232)	Controller USB TAPE A Connector	Controller USB TAPE A Connector
<p>RXD (2) ————— (3) TXD</p> <p>TXD (3) ————— (2) RXD</p> <p>GND (5) ————— (4) GND</p>		 <p>Top View</p>

**(COM PORT)**

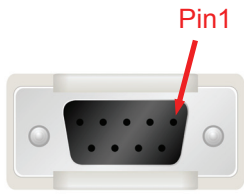
DOP 9 pin D-SUB male (RS-232)	Controller 9 pin D-SUB female (RS-232)	Controller 9 pin D-SUB female (RS-232)
<p>RXD (2) ————— (3) TXD</p> <p>TXD (3) ————— (2) RXD</p> <p>GND (5) ————— (5) GND</p>		 <p>Top View</p>

**VIPA PLC**

**[Back to Table](#)**

Its function is the same as [Siemens S7 300 PLC \(with PC Adaptor\)](#).

## YOKOGAWA ACE PLC

[Back to Table](#)

## A. HMI factory settings

Baud rate: 9600, 8, EVEN, 1. (ASCII code)

Controller station number: 1.

CPU NO. : 1.

Control area/status area: D1 / D10.



- 1) CheckSum and End character (CR, LF) are not used during communication. Therefore, the controller should be set to "Not using CheckSum and End character".
- 2) CPU number is used during communication, however, Screen Editor software does not have this selection. Therefore, if the user desires to set CPU number, please set HMI station number in "General" tab in the "Configuration" dialog box in "Options" menu (Options → "Configuration" → General). (HMI station number is regarded as CPU number. The default setting of HMI station number is 0, but 0 is an illegal number, the user must set it as a legal value.

## B. Definition of controller Read/Write address

## Registers

Register Type	Format	Word No.	Data Size
WORD_DEVICE_X	Xn	n: 201 ~ 65464	Word
WORD_DEVICE_Y	Yn	n: 201 ~ 65464	Word
WORD_DEVICE_I	In	n: 1 ~ 16384	Word
WORD_DEVICE_E	En	n: 1 ~ 4096	Word
WORD_DEVICE_L	Ln	n: 1 ~ 65488	Word
WORD_DEVICE_M	Mn	n: 1 ~ 9984	Word
WORD_DEVICE_TP	TPn	n: 1 ~ 3072	Word
WORD_DEVICE_CP	CPn	n: 1 ~ 3072	Word
WORD_DEVICE_D	Dn	n: 1 ~ 8192	Word
WORD_DEVICE_B	Bn	n: 1 ~ 32768	Word
WORD_DEVICE_W	Wn	n: 1 ~ 65499	Word
WORD_DEVICE_Z	Zn	n: 1 ~ 512	Word
WORD_DEVICE_V	Vn	n: 1 ~ 64	Word
WORD_DEVICE_R	Rn	n: 1 ~ 4096	Word
WORD_DEVICE_TS	TSn	n: 1 ~ 3072	Word
WORD_DEVICE_CS	CSn	n: 1 ~ 3072	Word

- WORD\_DEVICE\_X / WORD\_DEVICE\_Y: The last two digits of address must be 1 or the multiple of 16+1 and less than 65.

- WORD\_DEVICE\_I / WORD\_DEVICE\_E / WORD\_DEVICE\_L / WORD\_DEVICE\_M: Address must be 1 or the multiple of 16+1.
- WORD\_DEVICE\_X / WORD\_DEVICE\_Y / WORD\_DEVICE\_L / WORD\_DEVICE\_W: Valid address is inconsecutive.

**Contacts**

Contact type	Format	Bit No.
BIT_DEVICE_X	Xn	n: 201 ~ 65464
BIT_DEVICE_Y	Yn	n: 201 ~ 65464
BIT_DEVICE_I	In	n: 1 ~ 16384
BIT_DEVICE_E	En	n: 1 ~ 4096
BIT_DEVICE_L	Ln	n: 1 ~ 65488
BIT_DEVICE_M	Mn	n: 1 ~ 9984
BIT_DEVICE_TU	TUn	n: 1 ~ 3072
BIT_DEVICE_CU	CUn	n: 1 ~ 3072

- BIT\_DEVICE\_X / BIT\_DEVICE\_Y : the last two digits of address must be less than 65 (1 ~ 64).
- BIT\_DEVICE\_X / BIT\_DEVICE\_Y / BIT\_DEVICE\_L : valid address is inconsecutive.
- Multiple Duplicate:
  - The next Bit address of X264 is X301 (invalid addresses X265 ~ X300 are skipped)
  - The next Bit address of X364 is X401.
  - The address of Y is the same as X.
  - (The Word addresses of X and Y also skip invalid addresses automatically)

**C. Connections (Connector Pinouts)**

It needs to use specific cable of YOKOGAWA ACE PLC.

**RS-232**

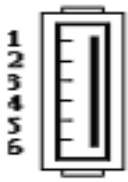
DOP 9 pin D-SUB male (RS-232)	Controller (6 pin) (RS-232 for YOKOGAWA)	Controller (6 pin) (RS-232 for YOKOGAWA)
RXD (2) ————— (1) TXD TXD (3) ————— (2) RXD GND (5) ————— (5) GND		 Top View



This page intentionally left blank.

## Free Manuals Download Website

<http://myh66.com>

<http://usermanuals.us>

<http://www.somanuals.com>

<http://www.4manuals.cc>

<http://www.manual-lib.com>

<http://www.404manual.com>

<http://www.luxmanual.com>

<http://aubethermostatmanual.com>

Golf course search by state

<http://golfingnear.com>

Email search by domain

<http://emailbydomain.com>

Auto manuals search

<http://auto.somanuals.com>

TV manuals search

<http://tv.somanuals.com>