

PORTABLE FORCED AIR HEATER

OWNER'S MANUAL

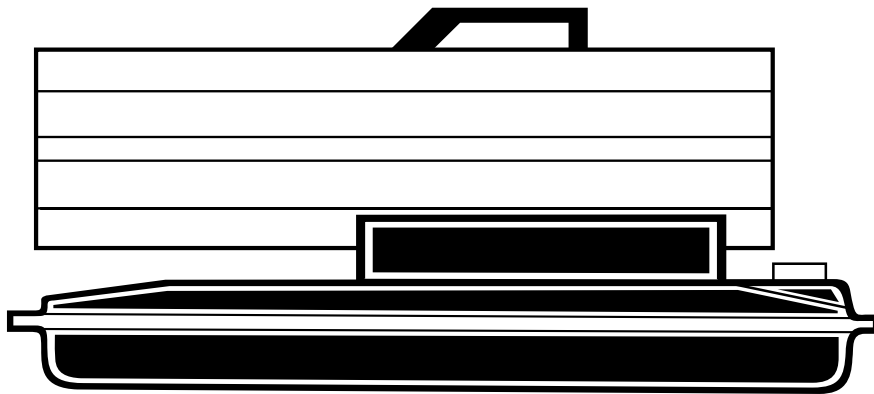

Heater Size: 70,000 Btu/Hr

Models: R70D and B70D

H.S.I. Series

IMPORTANT: Read and understand this manual before assembling, starting, or servicing heater. Improper use of heater can cause serious injury. Keep this manual for future reference.



70,000 Btu/Hr H.S.I. Series

PORTABLE FORCED AIR HEATERS

SAFETY INFORMATION

WARNINGS

IMPORTANT: Read this Owner's Manual carefully and completely before trying to assemble, operate, or service this heater. Improper use of this heater can cause serious injury or death from burns, fire, explosion, electrical shock, and carbon monoxide poisoning.

 DANGER: Carbon monoxide poisoning may lead to death!

Carbon Monoxide Poisoning: Early signs of carbon monoxide poisoning resemble the flu, with headaches, dizziness, and/or nausea. If you have these signs, the heater may not be working properly. **Get fresh air at once!** Have heater serviced. Some people are more affected by carbon monoxide than others. These include pregnant women, persons with heart or lung disease or anemia, those under the influence of alcohol, and those at high altitudes.

Make certain you read and understand all Warnings. Keep this manual for reference. It is your guide to safe and proper operation of this heater.

- Use only kerosene or No. 1 fuel oil to avoid risk of fire or explosion. Never use gasoline, naphtha, paint thinners, alcohol, or other highly flammable fuels.
- Fueling
 - a) Personnel involved with fueling shall be qualified and thoroughly familiar with the manufacturer's instructions and applicable federal, state, and local regulations regarding the safe fueling of heating units.

- b) Only the type of fuel specified on the heater's data plate shall be used.
 - c) All flame, including the pilot light, if any, shall be extinguished and the heater allowed to cool, prior to fueling.
 - d) During fueling, all fuel lines and fuel-line connections shall be inspected for leaks. Any leaks shall be repaired prior to returning the heater to service.
 - e) At no time shall more than one day's supply of heater fuel be stored inside a building in the vicinity of the heater. Bulk fuel storage shall be outside the structure.
 - f) All fuel storage shall be located a minimum of 25 feet from heaters, torches, welding equipment, and similar sources of ignition (exception: the fuel reservoir integral with the heater unit).
 - g) Whenever possible, fuel storage shall be confined to areas where floor penetrations do not permit fuel to drip onto or be ignited by a fire at lower elevation.
 - h) Fuel storage shall be in accordance with the federal, state, or local authority having jurisdiction.
- Never use heater where gasoline, paint thinner, or other highly flammable vapors are present.
 - Follow all local ordinances and codes when using heater.
 - Heaters used in the vicinity of tarpaulins, canvas, or similar enclosure materials shall be located a safe distance from such materials. The recommended minimum safe distance is 10 feet. It is further recommended that these enclosure materials be of a fire retardant nature. These enclosure materials shall be securely fastened to prevent them from igniting or from upsetting the heater due to wind action.
 - Use only in well-vented areas. Before using heater, provide at least a three-square-foot opening of fresh, outside air for each 100,000 Btu/Hr of rating. This heater produces carbon monoxide, which is listed by the State of California as a reproductive toxin under Proposition 65.
 - Use only in places free of flammable vapors or high dust content.
 - Use only the electrical voltage and frequency specified on model plate.
 - Use only a three-prong, grounded extension cord.
 - Minimum heater clearances from combustibles:
Outlet: 8 Ft. Sides: 4 Ft.
Top: 4 Ft. Rear: 4 Ft.
 - Locate heater on a stable and level surface if heater is hot or running or a fire may occur.
 - When moving or storing heater, keep heater in a level position or fuel spillage may occur.
 - Keep children and animals away from heater.
 - Unplug heater when not in use.
 - When used with thermostat, heater may start anytime.
 - Never use heater in living or sleeping areas.
 - Never block air inlet (rear) or air outlet (front) of heater.
 - Never move, handle, refuel, or service a hot, operating, or plugged-in heater.
 - Never attach duct work to front or rear of heater.
 - Approved by the New York City Fire Department under certificate of approval #4803, #4860, #4908, or #4909. To be used only at construction sites in accordance with applicable New York City Codes, Regulations, Rules, Directives, Permits, etc.

OWNER'S MANUAL

PRODUCT IDENTIFICATION

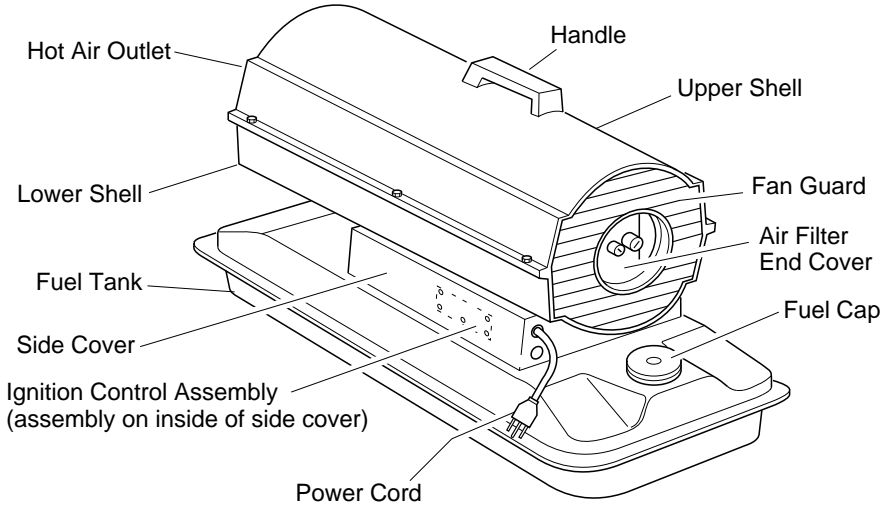

Figure 1 - 70,000 Btu/Hr

UNPACKING

1. Remove all packing items applied to heater for shipment.
2. Remove all items from carton.
3. Check items for shipping damage. If heater is damaged, promptly inform dealer where you bought heater.

THEORY OF OPERATION

The Fuel System: The air pump forces air through the air line. The air is then pushed through the nozzle. This air causes fuel to lift from the tank. A fine mist of fuel is sprayed into the combustion chamber.

The Air System: The motor turns the fan. The fan pushes air into and around the combustion chamber. This air is heated and provides a stream of clean, hot air.

The Ignition System: The ignition control assembly provides power to the ignitor. This ignites the fuel/air mixture in the combustion chamber.

The Flame-Out Control System: This system causes the heater to shut down if the flame goes out.

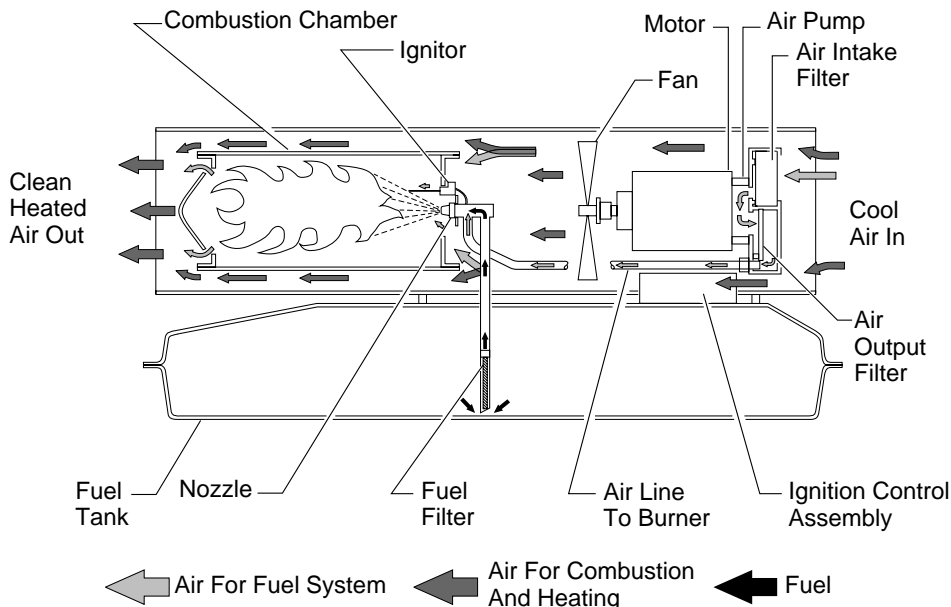

Figure 2 - Cross Section Operational View

70,000 Btu/Hr H.S.I. Series

PORTABLE FORCED AIR HEATERS

FUELS

⚠ WARNING: Use only kerosene or No. 1 fuel oil to avoid risk of fire or explosion. Never use gasoline, naphtha, paint thinners, alcohol, or other highly flammable fuels.

Do not use heavy fuels such as No. 2 fuel oil or No. 2 Diesel. Using heavy fuels will result in a clogged fuel filter and/or nozzle.

IMPORTANT: Use a KEROSENE ONLY storage container. Be sure storage container is clean. Foreign matter such as rust, dirt, or water will cause the ignition control assembly to shut down the heater. Foreign matter may also require you to clean fuel system often.

VENTILATION

⚠ Follow the minimum fresh, outside air ventilation requirements. If proper fresh, outside air ventilation is not provided, carbon monoxide poisoning can occur. Provide proper fresh, outside air ventilation before running heater.

Provide at least a three-square-foot opening of fresh, outside air for each 100,000 Btu/Hr rating. Provide extra fresh air if more heaters are being used.

Example: A 70,000 Btu/Hr heater requires one of the following:

- a two-car garage door (16 feet wide opening) raised two inches
- a single-car garage door (9 feet wide opening) raised three inches
- two windows (30 inches wide opening) raised six inches

OPERATION

⚠ WARNING: Review and understand the warnings in the *Safety Information* section, page 2. They are needed to safely operate this heater. Follow all local codes when using this heater.

TO START HEATER

1. Follow all ventilation and safety information.
2. Fill fuel tank with kerosene or No. 1 fuel oil.
3. Attach fuel cap.
4. Plug power cord of heater into three-prong, grounded extension cord. Extension cord must be at least six feet long.

Extension Cord Wire Size Requirements

- 6 to 10 feet long, use 18 AWG rated cord
 - 11 to 100 feet long, use 16 AWG rated cord
 - 101 to 200 feet long, use 14 AWG rated cord
5. Plug extension cord into standard 120 volt/60 hertz, three-hole, grounded outlet.

Note: Ignitor will preheat for five seconds then heater will start.

TO STOP HEATER

Unplug extension cord from outlet.

TO RESET HEATER

1. Unplug extension cord from outlet and wait 10 seconds (two minutes if heater has been running).
2. Plug extension cord into standard 120 volt/60 hertz, three-hole, grounded outlet.

Note: Ignitor will preheat for five seconds then heater will start.

OWNER'S MANUAL

STORING, TRANSPORTING, OR SHIPPING

Note: If shipping, transport companies require fuel tanks to be empty.

1. Drain fuel tank. Drain fuel through fuel cap opening. Be sure all fuel is removed.
2. If any debris is noted in old fuel, add 1 or 2 quarts of clean kerosene to tank, stir, and drain again. This will prevent excess debris from clogging filters during future use.
3. Replace fuel cap. Properly dispose of old and dirty fuel. Check with local automotive service stations that recycle oil.
4. If storing, store heater in dry place. Make sure storage place is free of dust and corrosive fumes.

IMPORTANT: Do not store kerosene over summer months for use during next heating season. Using old fuel could damage heater.

PREVENTATIVE MAINTENANCE SCHEDULE

 **WARNING:** Never service heater while it is plugged in, operating, or hot. Severe burns and electrical shock can occur.

Item	How Often	How To
Fuel tank	Flush every 150-200 hours of operation or as needed.	See <i>Storing, Transporting, or Shipping</i>
Air output and lint filters	Replace every 500 hours of operation or once a year.	See <i>Air Output, Air Intake, and Lint Filters</i> , page 7
Air intake filter	Wash and dry with soap and water every 500 hours of operation or replace as needed.	See <i>Air Output, Air Intake, and Lint Filters</i> , page 7
Fuel filter	Clean twice a heating season or replace as needed.	See <i>Fuel Filter</i> , page 8
Ignitor	No maintenance required.	
Fan blades	Clean each season or as needed.	See <i>Fan</i> , page 7
Motor	Not required/permanently lubricated	

70,000 Btu/Hr H.S.I. Series

PORTABLE FORCED AIR HEATERS

TROUBLESHOOTING

Note: For additional help, visit DESA International's technical service web site at www.desatech.com.

⚠ WARNING: Never service heater while it is plugged in, operating, or hot. Severe burns and electrical shock can occur.

FAULT CONDITION	POSSIBLE CAUSE	REMEDY	
Motor does not start five seconds after heater is plugged in	1. No power to heater	1. Check circuit breaker in electrical panel	
	⚠ WARNING: High voltage!		
	2. Bad electrical connection between motor and ignition control assembly or ignition control assembly and power cord	2. Check all electrical connections. See <i>Wiring Diagram</i> , page 11	
	3. Blown fuse on ignition control assembly	3. See <i>Ignition Control Assembly</i> , page 8	
	4. Binding pump rotor	4. If fan does not turn freely, see <i>Pump Rotor</i> , page 10	
	5. Defective ignition control assembly	5. Replace ignition control assembly	
Motor starts and runs but heater does not ignite	6. Defective motor	6. Replace motor	
	1. No fuel in tank	1. Fill tank with kerosene	
	2. Pump pressure incorrect	2. See <i>Pump Pressure Adjustment</i> , page 7	
	3. Dirty fuel filter	3. See <i>Fuel Filter</i> , page 8	
	4. Obstruction in nozzle	4. See <i>Nozzle Assembly</i> , page 9	
5. Water in fuel tank	5. Drain and flush fuel tank with clean kerosene. See <i>Storing, Transporting, or Shipping</i> , page 5		
⚠ WARNING: High voltage!			
Heater ignites but ignition control assembly shuts heater off after a short period of time	6. Bad electrical connection between ignitor and ignition control assembly	6. Check electrical connections. See <i>Wiring Diagram</i> , page 11	
	7. Defective ignitor	7. Replace ignitor, see page 8	
	8. Defective ignition control assembly	8. Replace ignition control assembly	
	1. Pump pressure incorrect	1. See <i>Pump Pressure Adjustment</i> , page 7	
2. Dirty air intake, air output, and/or lint filter	2. See <i>Air Output, Air Intake, and Lint Filters</i> , page 7		
3. Dirty fuel filter	3. See <i>Fuel Filter</i> , page 8		
4. Obstruction in nozzle	4. See <i>Nozzle Assembly</i> , page 9		
5. Photocell assembly not properly installed (not seeing the flame)	5. Make sure photocell boot is properly seated in bracket		
⚠ WARNING: High voltage!			
Heater ignites but ignition control assembly shuts heater off after a short period of time	6. Dirty photocell lens	6. Clean photocell lens	
	7. Bad electrical connection between photocell and ignition control assembly	7. Check electrical connections. See <i>Wiring Diagram</i> , page 11	
	8. Defective photocell	8. Replace photocell	
9. Defective ignition control assembly	9. Replace ignition control assembly		

SERVICE PROCEDURES

⚠ WARNING: Never service heater while it is plugged in, operating, or hot. Severe burns and electrical shock can occur.

UPPER SHELL REMOVAL

1. Remove screws along each side of heater using 5/16" nut-driver. These screws attach upper and lower shells together.
2. Lift upper shell off.
3. Remove fan guard.

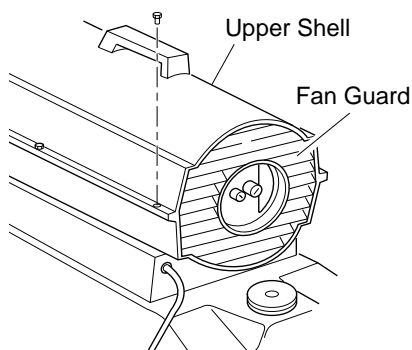

Figure 3 - Upper Shell Removal

FAN

IMPORTANT: Remove fan from motor shaft before removing motor from heater. The weight of the motor resting on the fan could damage the fan pitch.

1. Remove upper shell (see *Upper Shell Removal*).
2. Use 1/8" Allen wrench to loosen setscrew which holds fan to motor shaft.
3. Slip fan off motor shaft.
4. Clean fan using soft cloth moistened with kerosene or solvent.
5. Dry fan thoroughly.
6. Replace fan on motor shaft. Place fan hub flush with end of motor shaft (see *Figure 4*).
7. Place setscrew on flat of shaft. Tighten setscrew firmly (40-50 inch-pounds).
8. Replace fan guard and upper shell.

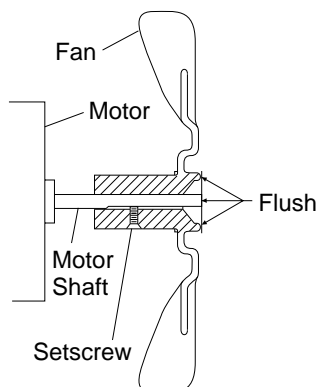

Figure 4 - Fan Cross Section

AIR OUTPUT, AIR INTAKE, AND LINT FILTERS

1. Remove upper shell (see *Upper Shell Removal*).
2. Remove filter end cover screws using 5/16" nut-driver.
3. Remove filter end cover.
4. Replace air output and lint filters.
5. Wash or replace air intake filter (see *Preventative Maintenance Schedule*, page 5).
6. Replace filter end cover.
7. Replace fan guard and upper shell. **IMPORTANT:** Do not oil filters.

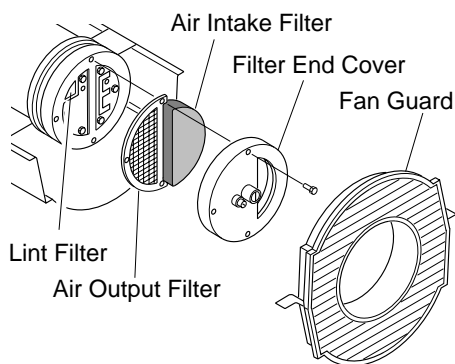

Figure 5 - Air Output, Air Intake, and Lint Filters

PUMP PRESSURE ADJUSTMENT

1. Remove pressure gauge plug from filter end cover.
2. Install accessory pressure gauge (part number HA1180).
3. Start heater (see *Operation*, page 4). Allow motor to reach full speed.
4. Using a flat blade screwdriver, adjust pressure. Turn relief valve to right to increase the pressure. Turn relief valve to left to decrease the pressure. Set pump pressure at 4.7 PSI.
5. Stop heater (see *Operation*, page 4).
6. Remove pressure gauge. Replace pressure gauge plug in filter end cover.

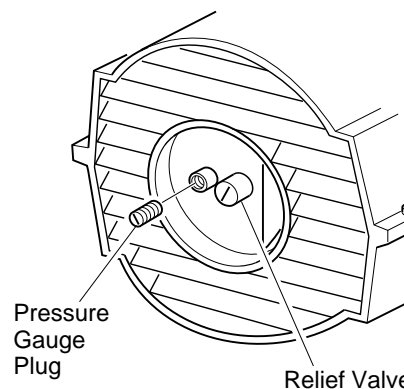

Figure 6 - Pressure Gauge Plug Removal

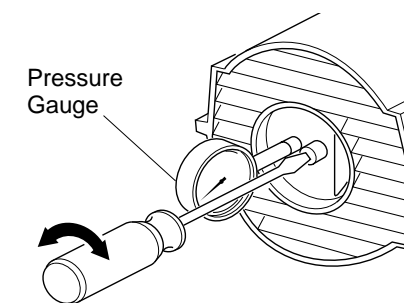

Figure 7 - Adjusting Pump Pressure

70,000 Btu/Hr H.S.I. Series

PORTABLE FORCED AIR HEATERS

SERVICE PROCEDURES

Continued

⚠ WARNING: Never service heater while it is plugged in, operating, or hot. Severe burns and electrical shock can occur.

FUEL FILTER

1. Remove 4 side cover screws using 5/16" nut-driver.
2. Remove side cover.
3. Pull upper fuel line off fuel filter neck.
4. Carefully pry bushing and fuel filter out of fuel tank.
5. Wash fuel filter with clean fuel and replace in tank.
6. Attach upper fuel line to fuel filter neck.
7. Replace side cover.

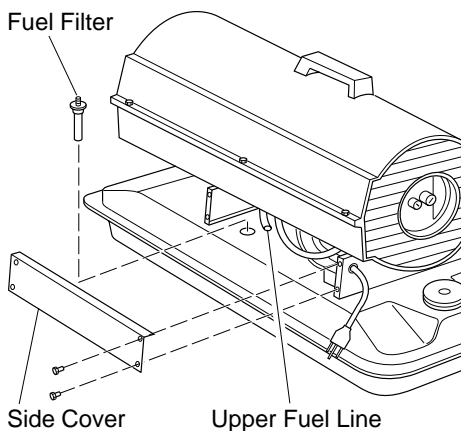

Figure 8 - Fuel Filter Removal

IGNITOR

1. Remove upper shell and fan guard (see page 7).
2. Remove fan (see page 7).
3. Remove 4 side cover screws with a 5/16" nut driver. Remove side cover (see Figure 8).
4. Disconnect ignitor wires (yellow) from ignition control assembly (see Figure 9). Pull the ignitor wires up through the hole in the lower shell.
5. Disconnect fuel line hose and air line hose. Remove photocell from photocell bracket (see Figure 9).

6. Remove combustion chamber. Stand combustion chamber on end with nozzle adapter bracket on top (see Figure 10).
7. Remove ignitor screw with a 1/4" nut driver. Carefully remove ignitor from nozzle adapter bracket.

⚠ CAUTION: Do not bend or strike ignitor element. Handle with care.

8. Carefully remove replacement ignitor from styrofoam packing.
9. Carefully guide ignitor into opening in nozzle adapter bracket. Do not strike ignitor element. Attach ignitor to nozzle adapter bracket with screw using a 1/4" nut driver (see Figure 10). Torque 8 to 15 in. lbs. Do not over torque.
10. Replace combustion chamber.
11. Route the ignitor wires back down through the hole in the lower shell. Connect wires to the ignition control assembly.
12. Replace side cover (see Figure 8).
13. Connect and route fuel line hose and air line hose to nozzle adapter (see Figure 9).
14. Replace photocell in photocell bracket. Route wires as shown in Figure 12, page 9.
15. Replace fan (see page 7).
16. Replace fan guard and upper shell (see page 7).

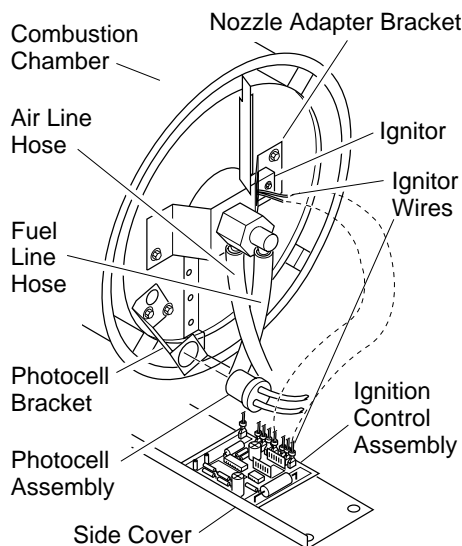

Figure 9 - Disconnecting Ignitor Wires from Ignition Control Assembly

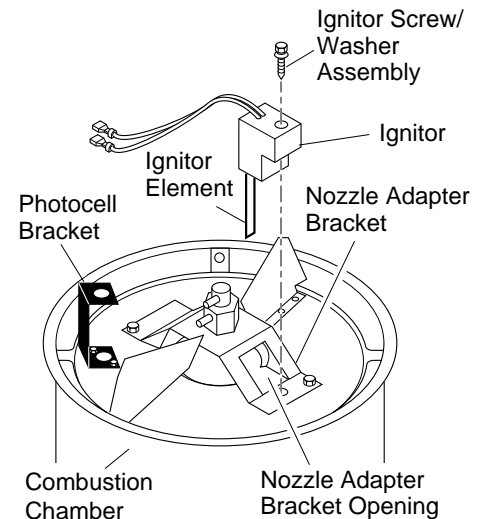

Figure 10 - Ignitor Replacement

IGNITION CONTROL ASSEMBLY

(Procedure for Replacing Fuse)

⚠ WARNING: High Voltage

1. Unplug heater
2. Remove side cover screws (4) using 5/16" nut-driver to expose ignition control assembly.
3. Remove fuse cover.
4. Remove fuse from fuse clips.
5. Replace fuse with fuse of the same type and rating (GMA-10). Do not substitute a fuse with a higher current rating.
6. Replace fuse cover.
7. Replace side cover.

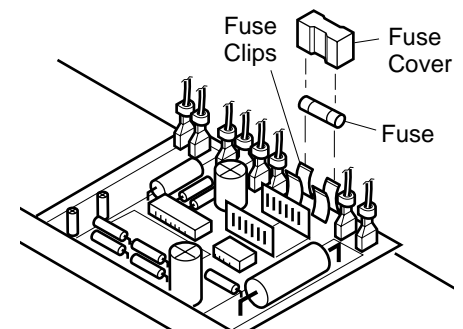

Figure 11 - Replacing Fuse

SERVICE PROCEDURES

Continued

NOZZLE ASSEMBLY

1. Remove upper shell (see page 7).
2. Remove fan (see page 7).
3. Remove fuel and air line hoses from nozzle assembly (see Figure 12).
4. Turn nozzle assembly 1/4 turn to left and pull toward motor to remove (see Figure 13).
5. Place plastic hex-body into vise and lightly tighten.
6. Carefully remove nozzle from the nozzle adapter using 5/8" socket wrench (see Figure 14).
7. Blow compressed air through face of nozzle. This will free any dirt in nozzle area.
8. Inspect nozzle seal for damage.
9. Replace nozzle into nozzle adapter until nozzle seats. Tighten 1/3 turn more using 5/8" socket wrench (40-45 inch-pounds).
10. Attach nozzle assembly to burner strap.
11. Attach and route fuel and airline hoses to nozzle assembly as shown (see Figure 12). Route photo cell wires as shown in Figure 12.
12. Replace fan (see page 7).
13. Replace fan guard and upper shell.

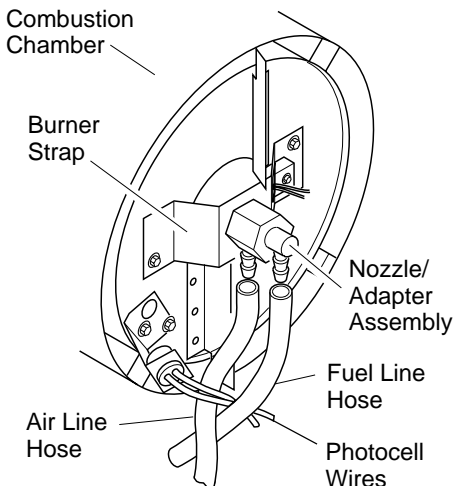

Figure 12 - Removing Air and Fuel Line Hoses

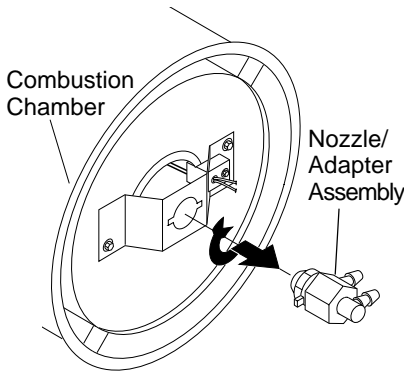

Figure 13 - Removing Nozzle/Adapter Assembly

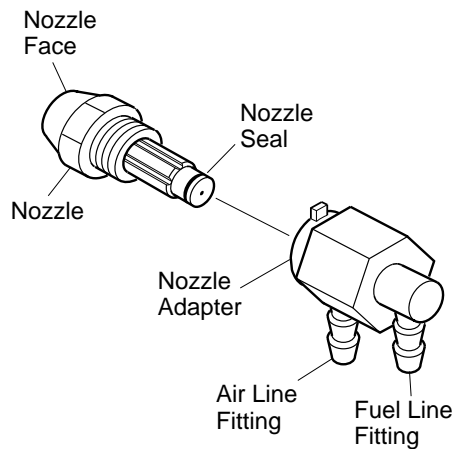

Figure 14 - Nozzle and Nozzle Adapter

FUEL AND AIR LINE REPLACEMENT AND PROPER ROUTING

1. Remove upper shell (see *Upper Shell Removal*, page 7).
2. Remove side cover screws using 5/16" nut driver (see Figure 8, page 8).
3. Remove side cover.
4. Inspect fuel and air line hoses for cracks and/or holes. If fuel line hose is damaged, disconnect from nozzle adapter (see Figure 12) and from fuel filter (see *Fuel Filter*, page 8). If air line hose is damaged, disconnect from nozzle adapter (see Figure 12) and from barb fitting on pump end cover (see Figure 15).
5. Install new air and/or fuel line. Attach one end of air line hose to barb fitting on pump end cover (see Figure 15) and the other end to nozzle adapter (see Figure 12). Attach one end of fuel line hose to fuel filter (see *Fuel Filter*, page 8) and the other end to nozzle adapter (see Figure 12). Route air and fuel line approximately as shown in Figure 12. **Note:** Route hoses as shown in Figure 12. Hoses are not to touch photocell bracket.
6. Replace side cover.
7. Replace upper shell and fan guard (see *Upper Shell Removal*, page 7).

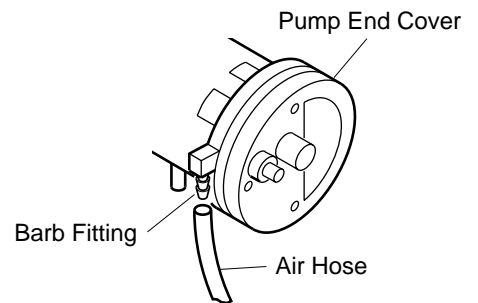

Figure 15 - Air Hose to Barb Fitting

70,000 Btu/Hr H.S.I. Series

PORTABLE FORCED AIR HEATERS

SERVICE PROCEDURES

Continued

PUMP ROTOR (Procedure if Rotor is Binding)

1. Remove upper shell (see page 7).
2. Remove filter end cover screws using 5/16" nut-driver.
3. Remove filter end cover and air filters.
4. Remove pump plate screws using 5/16" nut-driver.
5. Remove pump plate.
6. Remove rotor, insert, and blades.
7. Check for debris in pump. If debris is found, blow out with compressed air.
8. Install insert and rotor.
9. Check gap on rotor. Adjust to .003"/.004" if needed (see Figure 17).
Note: Rotate rotor one full turn to insure the gap is .003"/.004" at tightest position. Adjust if needed.
10. Install blades, pump plate, air filters, and filter end cover.
11. Replace fan guard and upper shell.
12. Adjust pump pressure (see page 7).
Note: If rotor is still binding, proceed as follows.
13. Perform steps 1 through 6 above.
14. Place fine grade sandpaper (600 grit) on flat surface. Sand rotor lightly in "figure 8" motion four times (see Figure 18).
15. Reinstall insert and rotor.
16. Perform steps 10 through 12 above.

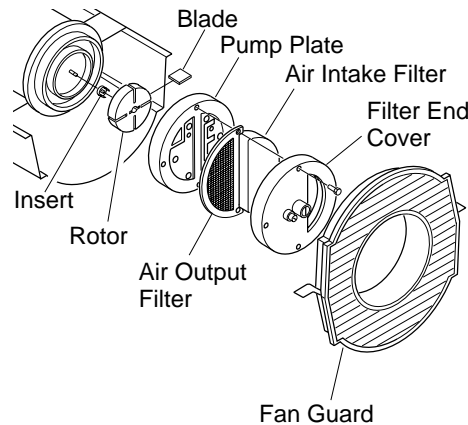

Figure 16 - Rotor Location

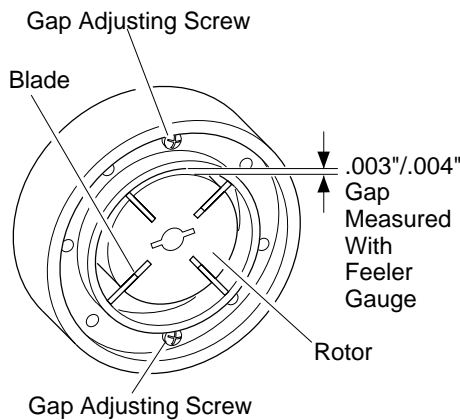

Figure 17 - Gap Adjusting Screw Locations

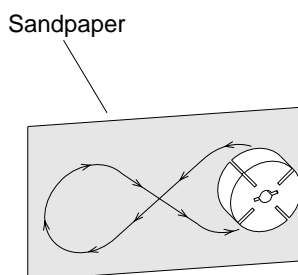

Figure 18 - Sanding Rotor

REPLACEMENT PARTS

Note: Use only original replacement parts. This will protect your warranty coverage for parts replaced under warranty.

PARTS UNDER WARRANTY

Contact authorized dealers of this product. If they can't supply original replacement part(s), call DESA International's Technical Service Dept. at 1-800-323-5190.

When calling DESA International, have ready:

- your name
- your address
- model number of your heater
- how heater was malfunctioning
- purchase date

Usually, we will ask you to return the defective part to the factory.

PARTS NOT UNDER WARRANTY

Contact authorized dealers of this product. If they can't supply original replacement part(s), call DESA International's Parts Department at 1-800-972-7879 for referral information. Parts Centrals are listed in the Authorized Service Center booklet supplied with heater.

When calling DESA International, have ready:

- model number of your heater
- the replacement part number

TECHNICAL SERVICE

You may have further questions about operation or troubleshooting. If so, contact DESA International's Technical Service Dept. at 1-800-323-5190.

You can also visit DESA International's technical services web site at www.desatech.com.

OWNER'S MANUAL

SPECIFICATIONS

Output Rating (Btu/Hr)	70,000
Fuel Use Only Kerosene or No. 1 Fuel Oil	
Fuel Tank Capacity (U.S. Gal.)	5.0
Fuel Consumption (Gal. Per Hr.)	.52
Electric Requirements	120 V/60 Hz
Amperage (Normal Run)	2.8
Hot Air Output (CFM)	360
Motor RPM	3440
Motor HP	1/8
Shipping Weight (Approximate Pounds)	36
Heater Weight without Fuel (Approximate Pounds)	31

WIRING DIAGRAM

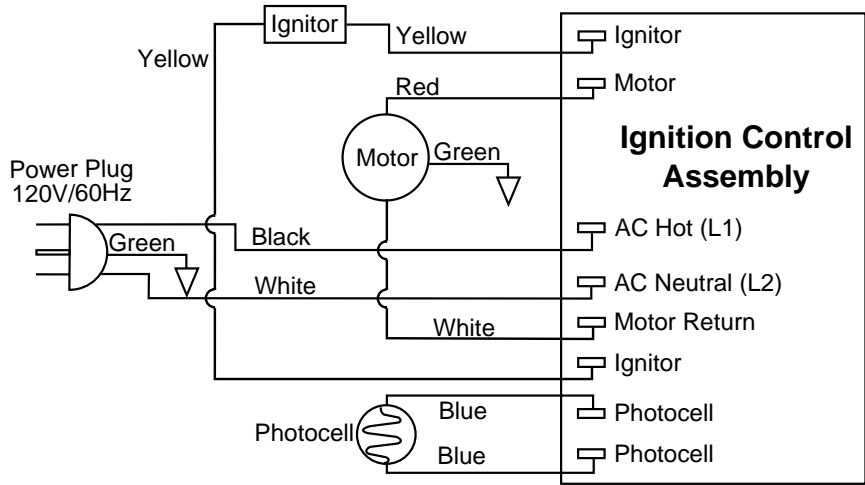
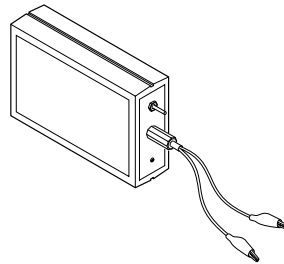

Figure 19 - Wiring Diagram

ACCESSORIES

Purchase accessories and parts from your nearest dealer or service center. If they can not supply these accessories or parts, either contact your nearest Parts Central or DESA International for referral information. Parts Centrals are listed in the Authorized Service Center booklet supplied with heater.

DESA International
P.O. Box 90004
Bowling Green, KY
42102-9004
1-800-972-7879
Parts Department



IGNITION CONTROL ASSEMBLY/PHOTOCELL TESTER - HA1170

Special tool used to test the ignition control assembly and photocell.

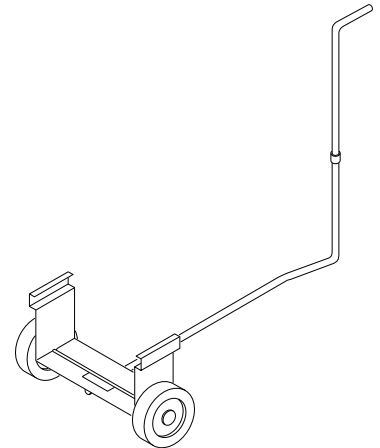

STANDARD WHEELS AND HANDLE KIT - HA1206

Makes heater even more portable and convenient. Easy to assemble.

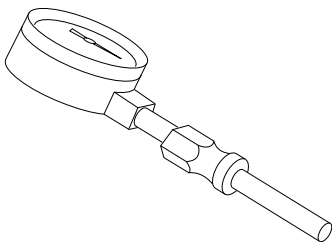

AIR GAUGE KIT - HA1180

Special tool to check pump pressure.

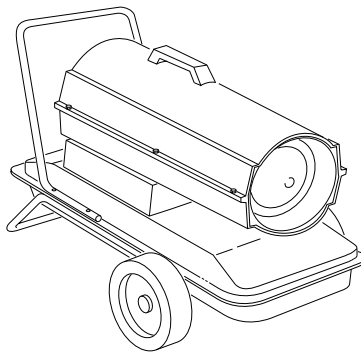

HEAVY DUTY WHEELS AND HANDLE KIT - HA1202

For heavy duty applications. Makes your heater even more portable and convenient.

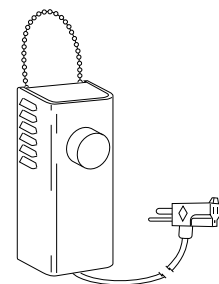

THERMOSTAT KIT - HA1210

Keeps your building at the temperature you select day and night. Helps economize on fuel.

70,000 Btu/Hr H.S.I. Series PORTABLE FORCED AIR HEATERS

ILLUSTRATED PARTS BREAKDOWN

R70D
B70D

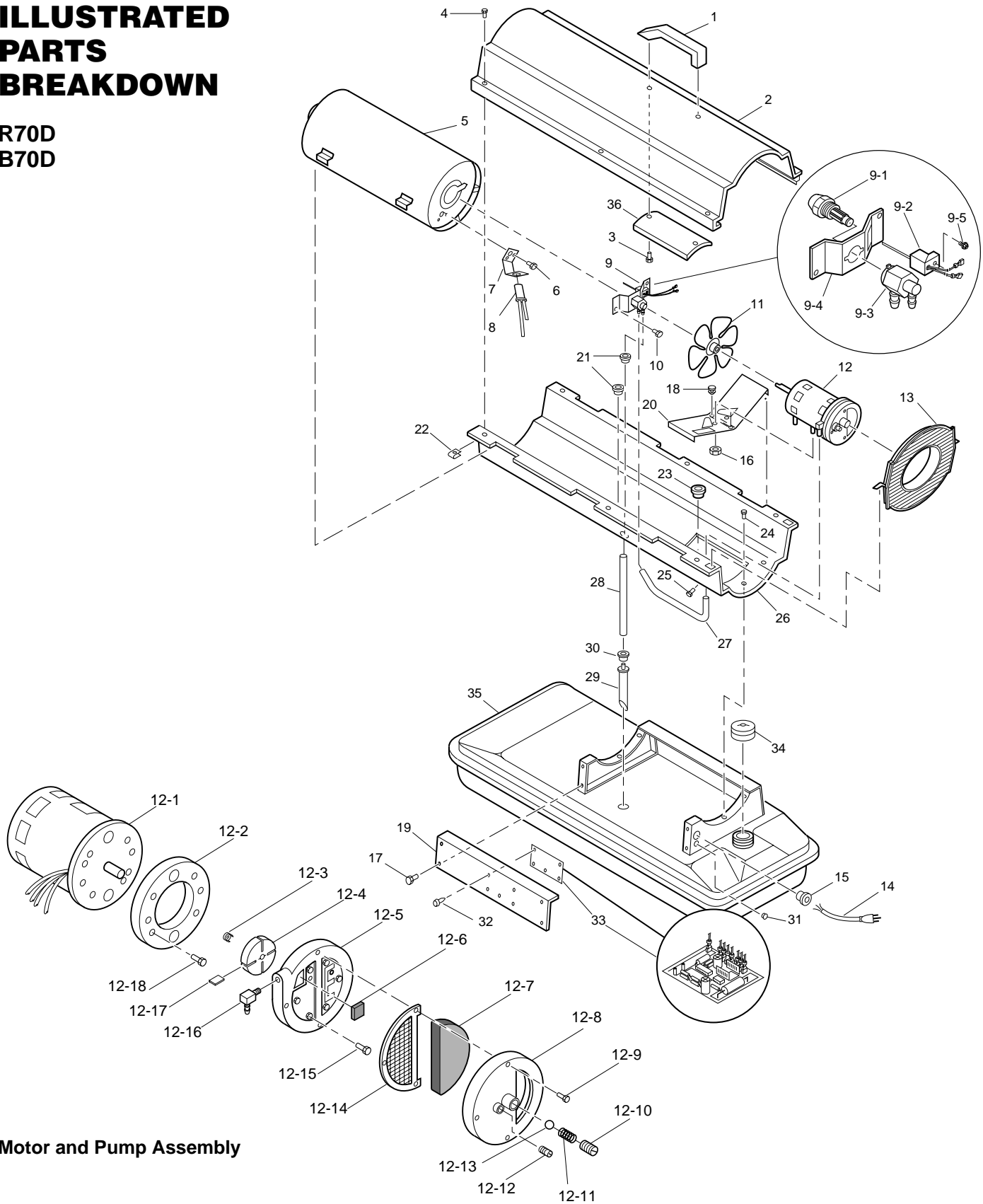

OWNER'S MANUAL

PARTS LIST

R70D
B70D

This list contains replaceable parts used in your heater. When ordering parts, be sure to provide the correct model and serial numbers (from the model plate), then the part number and description of the desired part.

KEY NO.	PART NUMBER	DESCRIPTION	QTY.	KEY NO.	PART NUMBER	DESCRIPTION	QTY.
1	M51104-01	Handle	1	12-17	M8643**	Blade	4
2	098511-36	Upper Shell (R70D)	1	12-18	FHPF3-5C	Screw, #10-32 x 5/8"	2
	098511-54	Upper Shell (B70D)	1	13	M51105-01	Fan Guard	1
3	M11084-29	Screw, #10-16 x 3/4"	2	14	098219-31	Power Cord	1
4	100647-01	Screw, #10-16 x 1/2"	6	15	M11143-1	Strain Relief Bushing	1
5	098512-51	Combustion Chamber	1	16	NTC-4C	Hex Lock Nut, 1/4-20	2
6	M10908-2	Screw, #6-32 x 3/8"	2	17	M11084-26	Screw, #10-16 x 3/8"	4
7	103154-03	Photocell Bracket	1	18	M50631	Rubber Bumper	2
8	M16656-23	Photocell Assembly	1	19	097461-03AA	Side Cover	1
9	Δ	Burner Head Assembly	1	20	101205-01	Motor Bracket	1
9-1	100735-18	Nozzle Assembly	1	21	M30865-02	Bushing	2
9-2	102548-03	Ignitor Kit	1	22	M11271-8	Clip Nut	6
9-3	104056-01	Nozzle Adapter	1	23	M50104-02	Bushing	1
9-4	102336-01	Nozzle Adapter Bracket	1	24	M11084-26	Screw, #10-16 x 3/8"	6
9-5	104023-01	Screw/Washer Assembly	1	25	M10908-14	Screw, #8-32 x 3/8"	1
10	M11084-26	Screw, #10-16 x 3/8"	2	26	098511-18	Lower Shell (R70D)	1
11	M29678	Fan	1		098511-12	Lower Shell (B70D)	1
12	Δ	Motor and Pump Assembly	1	27	M50814-06	Rubber Airline	1
12-1	102001-20	Motor	1	28	079973-01	Fuel Line	1
12-2	079975-02	Pump Body	1	29	M50876-05	Fuel Filter (with bushing)	1
12-3	M22009**	Insert	1	30	M10990-3	Rubber Bushing	1
12-4	M22456-1**	Rotor	1	31	101695-01	Button Plug	1
12-5	M29608	Pump End Cover	1	32	102349-01	PCB Support	5
12-6	M29632 ⊕	Lint Filter	1	33	104068-02	Ignition Control Assembly	1
12-7	M29633 ⊕	Intake Filter	1	34	097702-01	Fuel Cap (Includes Gasket)	1
12-8	M29609	Filter End Cover	1	35	098513-62	Fuel Tank	1
12-9	M12461-31	Screw, #10-32 x 1"	3	36	M51108-01	Shell Heat-Shield	1
12-10	M27694 ∞	Adjusting Screw	1	PARTS AVAILABLE - NOT SHOWN			
12-11	M10993-1 ∞	Pressure Relief Spring	1		097204-03	Tradename Decal (R70D)	2
12-12	M22997 ∞	Plug	1		097646-02	Tradename Decal (B70D)	2
12-13	M8940 ∞	Steel Ball, 1/4" Diameter	1		098493-01	General Information Decal	1
12-14	M29612-01 ⊕	Output Filter	1		103814-01	Wire Tie	1
12-15	M12461-31	Screw, #10-32 x 1"	6				
12-16	103676-01	Nylon Elbow, 90°	1				

Δ Not available as an assembly

** Included in Rotor Kit (part No. HA3004)

⊕ Included in Filter Kit (Part No. HA3014)

∞ Included in Pump Adjustment Kit (Part No. HA3020)

WARRANTY AND REPAIR SERVICE

LIMITED WARRANTY

DESA International warrants this product and any parts thereof, to be free from defects in materials and workmanship for one (1) year from the date of first purchase when operated and maintained in accordance with instructions. This warranty is extended only to the original retail purchaser, when proof of purchase is provided.

This warranty covers only the cost of parts and labor required to restore the product to proper operating condition. Transportation and incidental costs associated with warranty repairs are not reimbursable under this warranty.

Warranty service is available only through authorized dealers and service centers.

This warranty does not cover defects resulting from misuse, abuse, negligence, accidents, lack of proper maintenance, normal wear, alteration, modification, tampering, contaminated fuels, repair using improper parts, or repair by anyone other than an authorized dealer or service center. Routine maintenance is the responsibility of the owner.

THIS EXPRESS WARRANTY IS GIVEN IN LIEU OF ANY OTHER WARRANTY EITHER EXPRESSED OR IMPLIED, INCLUDING WARRANTIES OF MERCHANTABILITY AND FITNESS FOR A PARTICULAR PURPOSE.

DESA International assumes no responsibility for indirect, incidental or consequential damages. Some states do not allow the exclusion or limitation of incidental or consequential damages or limitations or exclusions may not apply to you. This Limited Warranty gives you specific legal rights and you may also have other rights which vary from state to state.

WARRANTY SERVICE

Should your heater require service, return it to your nearest authorized service center. Proof of purchase must be presented with the heater. The heater will be inspected. A defect may be caused by faulty materials or workmanship. If so, DESA International will repair or replace the heater without charge.

REPAIR SERVICE

Return the heater to your nearest authorized service center. Each Service Center is independently owned and operated. Repairs not covered by the warranty will be billed at standard prices. When writing for information regarding your heater, be sure to include the model number and serial number as shown on the model plate. We reserve the right to amend these specifications at any time without notice.

Illustrated parts lists can be obtained free of charge. Send a self addressed stamped envelope to the address listed below. List the heater model number and the date located in the lower right corner of this page. A service manual may be purchased from the address listed below. Send a check for \$5.00 payable to DESA International.

KEEP THIS WARRANTY

Model No. _____
Serial No. _____
Date of Purchase _____

(To be filled in by purchaser)

DESA
INTERNATIONAL
Corporate Headquarters
2701 Industrial Drive
P.O. Box 90004
Bowling Green, KY 42102-9004
www.desatech.com



103685 01

NOT A UPC

For information, write: DESA International, P.O. Box 90004
Bowling Green, Kentucky 42102-9004 ATTN: Customer Service Department
When writing, always include model number and serial number.

103685-01
Rev. E
02/99

Free Manuals Download Website

<http://myh66.com>

<http://usermanuals.us>

<http://www.somanuals.com>

<http://www.4manuals.cc>

<http://www.manual-lib.com>

<http://www.404manual.com>

<http://www.luxmanual.com>

<http://aubethermostatmanual.com>

Golf course search by state

<http://golfingnear.com>

Email search by domain

<http://emailbydomain.com>

Auto manuals search

<http://auto.somanuals.com>

TV manuals search

<http://tv.somanuals.com>