

PORTABLE FORCED AIR HEATERS

OWNER'S MANUAL

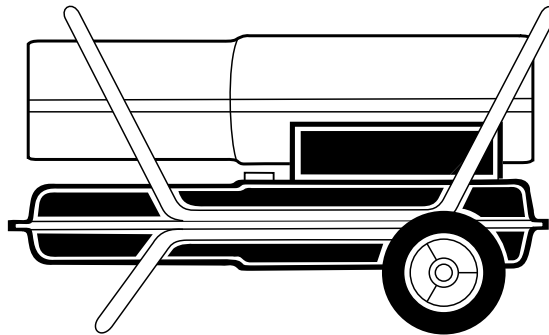

Model BY100ECA 100,000 Btu/Hr 120v/60 Hz

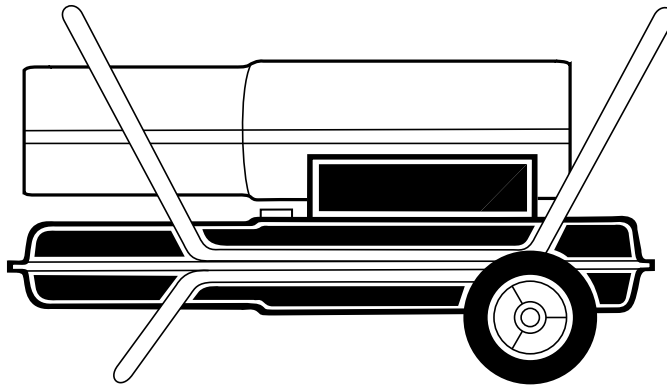

Model BY150ECA 150,000 Btu/Hr 120v/60 Hz

IMPORTANT

Read and understand this manual before assembling, starting, or servicing heater. Improper use of heater can cause serious injury. Keep this manual for future reference.



CONTENTS

SECTION	PAGE
Safety Information	2
Product Identification	4
Unpacking	5
Assembly	5
Theory of Operation	6
Fuels	6
Ventilation	7
Operation	7
Storing, Transporting, or Shipping	8
Preventative Maintenance Schedule	8
Troubleshooting	9
Service Procedures	10
Upper Shell Removal	10
Fan	10
Air Output, Air Intake, and Lint Filters	10
Pump Pressure Adjustment	11
Fuel Filter	11
Spark Plug	12
Nozzle	12
Pump Rotor	13
Specifications	14
Wiring Diagrams	14
Replacement Part and Accessory	14
Illustrated Parts Breakdown	16
Wheels and Handle	15
Model BY100ECA, 100,000 Btu/Hr	16
Model BY150ECA, 150,000 Btu/Hr	18
EC Conformity Declaration	20
Warranty and Repair Service	Back Cover

SAFETY INFORMATION

WARNINGS

IMPORTANT: Read this Owner's Manual carefully and completely before trying to assemble, operate, or service this heater. Improper use of this heater can cause serious injury or death from burns, fire, explosion, electrical shock, and carbon monoxide poisoning.

DANGER

Carbon monoxide poisoning may lead to death!

Carbon Monoxide Poisoning: Early signs of carbon monoxide poisoning resemble the flu, with headaches, dizziness, and/or nausea. If you have these signs, the heater may not be working properly. **Get fresh air at once!** Have heater serviced. Some people are more affected by carbon monoxide than others. These include pregnant women, persons with heart or lung disease or anemia, those under the influence of alcohol, and those at high altitudes.

Make certain you read and understand all Warnings. Keep this manual for reference. It is your guide to safe and proper operation of this heater.

SAFETY INFORMATION

Continued

WARNINGS *(Continued)*

- Use only kerosene or No. 1 fuel oil to avoid risk of fire or explosion. Never use gasoline, naphtha, paint thinners, alcohol, or other highly flammable fuels.
- Fueling
 - a) Personnel involved with fueling shall be qualified and thoroughly familiar with the manufacturer's instructions and applicable federal, state, and local regulations regarding the safe fueling of heating units.
 - b) Only the type of fuel specified on the heater's data plate shall be used.
 - c) All flame, including the pilot light, if any, shall be extinguished and the heater allowed to cool, prior to fueling.
 - d) During fueling, all fuel lines and fuel-line connections shall be inspected for leaks. Any leaks shall be repaired prior to returning the heater to service.
 - e) At no time shall more than one day's supply of heater fuel be stored inside a building in the vicinity of the heater. Bulk fuel storage shall be outside the structure.
 - f) All fuel storage shall be located a minimum of 762 cm (25 feet) from heaters, torches, welding equipment, and similar sources of ignition (exception: the fuel reservoir integral with the heater unit).
 - g) Whenever possible, fuel storage shall be confined to areas where floor penetrations do not permit fuel to drip onto or be ignited by a fire at lower elevation.
 - h) Fuel storage shall be in accordance with the federal, state, or local authority having jurisdiction.
- Never use heater where gasoline, paint thinner, or other highly flammable vapors are present.
- Follow all local ordinances and codes when using heater.
- Heaters used in the vicinity of tarpaulins, canvas, or similar enclosure materials shall be located a safe distance from such materials. The recommended minimum safe distance is 305 cm (10 feet). It is further recommended that these enclosure materials be of a fire retardant nature. These enclosure materials shall be securely fastened to prevent them from igniting or from upsetting the heater due to wind action.
- Use only in well-vented areas. Before using heater, provide at least a 2800 square cm (three-square-foot) opening of fresh, outside air for each 100,000 Btu/Hr of rating.
- Use only in places free of flammable vapors or high dust content.
- Use only the electrical voltage and frequency specified on model plate.
- Use only a three-prong, grounded extension cord.
- Minimum heater clearances from combustibles:
 - Outlet: 250 cm (8 Ft.) Sides, top, and rear: 125 cm (4 Ft.)
- Locate heater on a stable and level surface if heater is hot or running or a fire may occur.
- When moving or storing heater, keep heater in a level position or fuel spillage may occur.
- Keep children and animals away from heater.
- Unplug heater when not in use.
- When used with thermostat, heater may start anytime.
- Never use heater in living or sleeping areas.
- Never block air inlet (rear) or air outlet (front) of heater.
- Never move, handle, refuel, or service a hot, operating, or plugged-in heater.
- Never attach duct work to front or rear of heater.

PRODUCT IDENTIFICATION

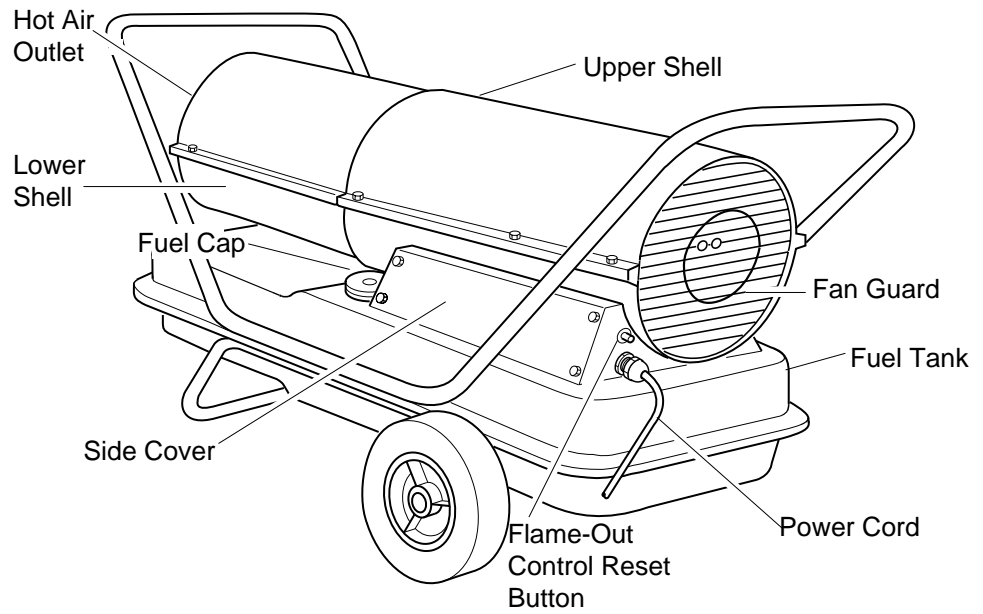

Figure 1 - 100,000 Btu/Hr Model

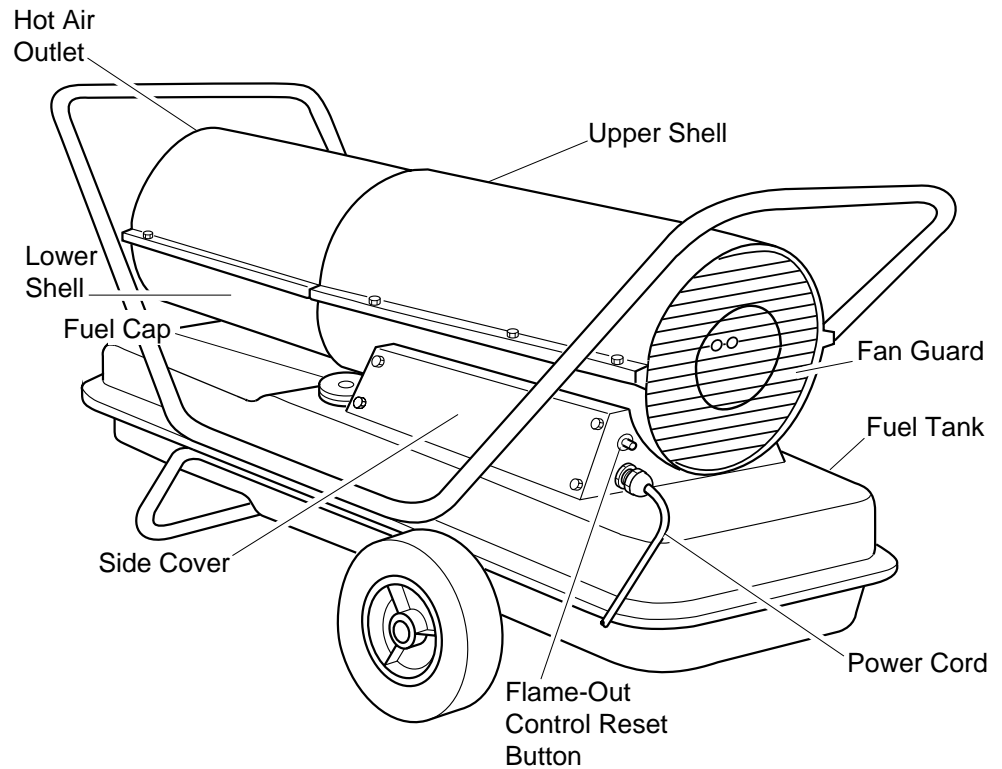

Figure 2 - 150,000 Btu/Hr Model

UNPACKING

1. Remove all packing items applied to heater for shipment.
2. Remove all items from carton.
3. Check items for shipping damage. If heater is damaged, promptly inform dealer where you bought heater.

ASSEMBLY

These models are furnished with wheels and a front handle. Some models are furnished with a rear handle also. Wheels, handle(s), and the mounting hardware are found in the shipping carton.

Tools Needed

- Medium Phillips Screwdriver
- 3/8" Open or Adjustable Wrench
- Hammer

1. Slide axle through wheel support frame. Install wheels on axle.
IMPORTANT: When installing wheels, point extended hub of wheels toward wheel support frame (see Figure 3).
2. Place cap nuts on axle ends. Gently tap with hammer to secure.
3. Place heater on wheel support frame. Make sure air inlet end (rear) of heater is over wheels. Line up holes on fuel tank flange with holes on wheel support frame.
4. Place front handle and rear handle on top of fuel tank flange. Insert screws through handles, fuel tank flange, and wheel support frame. Attach nut finger tight after each screw is inserted.
5. After all screws are inserted, tighten nuts firmly.

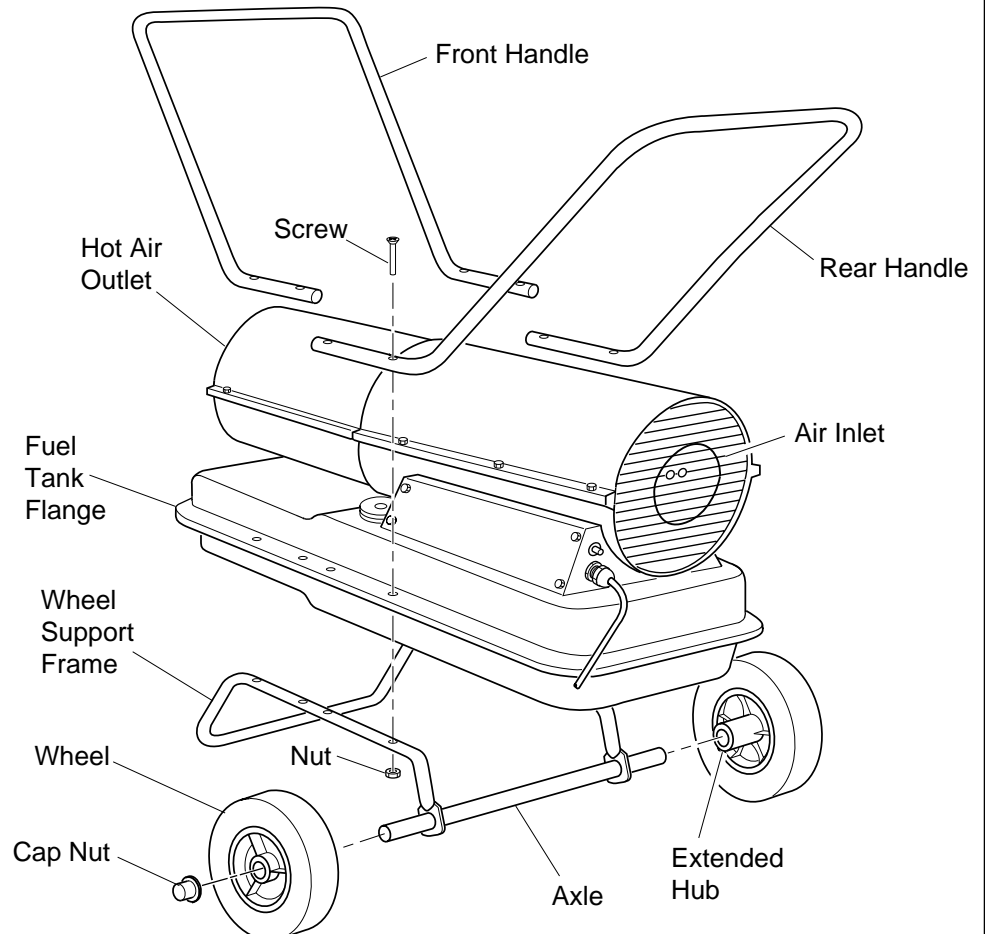

Figure 3 - Wheel and Handle Assembly

THEORY OF OPERATION

The Fuel System: The air pump forces air through the air line. The air is then pushed through the burner head nozzle. This air causes fuel to lift from the tank. A fine mist of fuel is sprayed into the combustion chamber.

The Air System: The motor turns the fan. The fan pushes air into and around the combustion chamber. This air is heated and provides a stream of clean, hot air.

The Ignition System: The electronic ignitor sends voltage to the spark plug. The spark plug ignites the fuel and air mixture.

The Flame-Out Control System: This system causes the heater to shut down if the flame goes out.

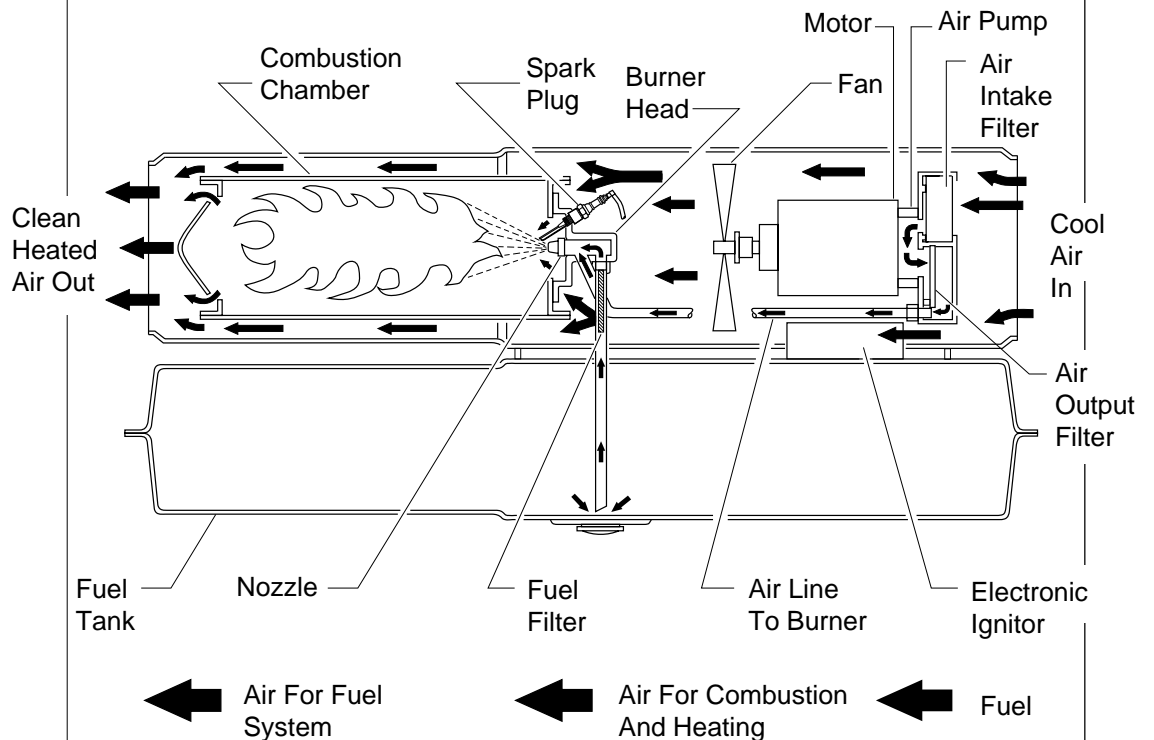

Figure 4 - Cross Section Operational View

FUELS

⚠ WARNING

Use only kerosene or No. 1 fuel oil to avoid risk of fire or explosion. Never use gasoline, naphtha, paint thinners, alcohol, or other highly flammable fuels.

Do not use heavy fuels such as No. 2 fuel oil or No. 2 Diesel. Using heavy fuels will result in:

- clogged fuel filter and nozzle
- carbon build up on spark plug
- the need of non-toxic anti-icer in fuel during very cold weather

IMPORTANT: Use a KEROSENE ONLY storage container. Be sure storage container is clean. Foreign matter such as rust, dirt, or water will cause the flame-out control to shut down heater. Foreign matter may also require you to clean fuel system often.

VENTILATION

⚠ WARNING

Follow the minimum fresh, outside air ventilation requirements. If proper fresh, outside air ventilation is not provided, carbon monoxide poisoning can occur. Provide proper fresh, outside air ventilation before running heater.

Provide a fresh air opening of at least 2800 square cm (three square feet) for each 100,000 Btu/Hr rating. Provide extra fresh air if more heaters are being used.

Example: A 150,000 Btu/Hr heater requires one of the following:

- a two-car garage door raised 15.24 cm (six inches)
- a single-car garage door raised 22.86 cm (nine inches)
- two, 76.20 cm (thirty-inch) windows raised 30.48 cm (twelve inches)

OPERATION

⚠ WARNING

Review and understand the warnings in the Safety Information Section, pages 2 and 3. They are needed to safely operate this heater. Follow all local codes when using this heater.

To Start Heater

1. Follow all ventilation and safety information.
2. Fill fuel tank with kerosene or No. 1 fuel oil.
3. Attach fuel cap.
4. Plug power cord of heater into standard 120 volt/60 hertz, grounded (earthed) outlet. Use an extension cord if needed. Use only a three-prong, grounded (earthed) extension cord.

Extension Cord Wire Size Requirements

Up to 30.5 meters (100 feet) long, use 1.0 mm² (16 AWG) conductor

30.6 to 61 meters (101 to 200 feet) long, use 1.5 mm² (14 AWG) conductor

Heater will start when power cord is plugged into outlet. If not, push in flame-out control reset button (see Figure 5).

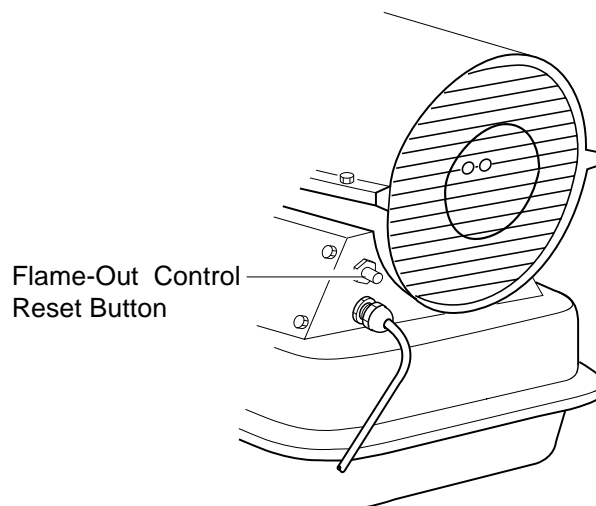

Figure 5 - Flame-Out Control Reset Button

OPERATION

Continued

STORING, TRANSPORTING, OR SHIPPING

PREVENTATIVE MAINTENANCE SCHEDULE

To Stop Heater

1. Unplug extension cord from outlet.

To Restart Heater

1. Wait two minutes after stopping heater.
2. Repeat steps under *To Start Heater*, page 7.

Note: If shipping, transport companies require fuel tanks to be empty.

1. Drain fuel tank.

Note: Some models have drain plug on underside of fuel tank. If so, remove drain plug to drain all fuel. If heater does not have drain plug, drain fuel through fuel cap opening. Be sure all fuel is removed.

2. Replace drain plug if provided.
3. If any debris is noted in old fuel, add 1 or 2 quarts of clean kerosene to tank, stir, and drain again. This will prevent excess debris from clogging filters during future use.
4. Replace fuel cap or drain plug. Properly dispose of old and dirty fuel. Check with local automotive service stations that recycle oil.
5. If storing, store heater in dry place. Make sure storage place is free of dust and corrosive fumes.

IMPORTANT: Do not store kerosene over summer months for use during next heating season. Using old fuel could damage heater.

WARNING

Never service heater while it is plugged in, operating, or hot. Severe burns and electrical shock can occur.

<u>Item</u>	<u>How Often</u>	<u>How To</u>
Fuel tank	Flush every 150-200 hours of operation or as needed.	See <i>Storing, Transporting, or Shipping</i> , above.
Air output and lint filters	Replace every 500 hours of operation or once a year.	See <i>Air Output, Air Intake, and Lint Filters</i> , page 10.
Air intake filter	Wash and dry with soap and water every 500 hours of operation or replace as needed.	See <i>Air Output, Air Intake, and Lint Filters</i> , page 10.
Fuel filter	Clean twice a heating season or replace as needed.	See <i>Fuel Filter</i> , page 11.
Spark plug	Clean and regap every 600 hours operation or replace as needed.	See <i>Spark Plug</i> , page 12.
Fan blades	Clean each season or as needed.	See <i>Fan</i> , page 10.
Motor	Not required/permanently lubricated	

TROUBLE-SHOOTING

WARNING

Never service heater while it is plugged in, operating, or hot. Severe burns and electrical shock can occur.

<u>OBSERVED FAULT</u>	<u>POSSIBLE CAUSE</u>	<u>REMEDY</u>
Heater ignites, but flame-out control shuts off heater after a short period of time.	Wrong pump pressure	See <i>Pump Pressure Adjustment</i> , page 11.
	Dirty air output, air intake and lint filters	See <i>Air Output, Air Intake and Lint Filters</i> , page 10.
	Dirty fuel filter	See <i>Fuel Filter</i> , page 11.
	Dirt in nozzle	See <i>Nozzle</i> , page 12.
	Dirty photocell lens	Clean photocell lens.
	Bad flame-out control	Replace flame-out control.
Heater will not ignite, but motor runs for a short period of time.	Wrong pump pressure	See <i>Pump Pressure Adjustment</i> , page 11.
	Carbon deposits on spark plug and/or improper gap	See <i>Spark Plug</i> , page 12.
	Dirty fuel filter	See <i>Fuel Filter</i> , page 11.
	Dirt in nozzle	See <i>Nozzle</i> , page 12.
	Water in fuel tank	Drain and flush fuel tank with clean kerosene. See <i>Storing, Transporting, or Shipping</i> , page 8.
 WARNING: High voltage!		
	Electronic ignitor not grounded	Make sure electronic ignitor mounting is tight.
	Bad electronic ignitor	Replace electronic ignitor.
Motor does not start when heater is plugged in, fan rotates slowly or does not turn.	Flame-out control not reset	Press flame-out control reset button.
	Solid state relay not allowed to reset	Wait two minutes before trying to restart heater.
	Binding pump rotor	If fan is hard to turn, see <i>Pump Rotor</i> , page 13.

SERVICE PROCEDURES

⚠ WARNING

Never service heater while it is plugged in, operating, or hot. Severe burns and electrical shock can occur.

Upper Shell Removal

1. Remove screws along each side of heater using 5/16" nut-driver. These screws attach upper and lower shells together.
2. Lift upper shell off.
3. Remove fan guard.

Fan

IMPORTANT: Remove fan from motor shaft before removing motor from heater. The weight of the motor resting on the fan could damage the fan pitch.

1. Remove upper shell (see above).
2. Use 1/8" allen wrench to loosen set-screw which holds fan to motor shaft.
3. Slip fan off motor shaft.
4. Clean fan using soft cloth moistened with kerosene or solvent.
5. Dry fan thoroughly.
6. Replace fan on motor shaft. Place fan hub flush with end of motor shaft (see Figure 7).
7. Place setscrew on flat of shaft. Tighten setscrew firmly (4.5-5.6 n-m/40-50 inch-pounds).
8. Replace fan guard and upper shell.

Air Output, Air Intake, and Lint Filters

1. Remove upper shell (see above).
2. Remove filter end cover screws using 5/16" nut-driver.
3. Remove filter end cover.
4. Replace air output and lint filters.
5. Wash or replace air intake filter (see Preventative Maintenance Schedule, page 8).
6. Replace filter end cover.
7. Replace fan guard and upper shell.

IMPORTANT: Do not oil filters.

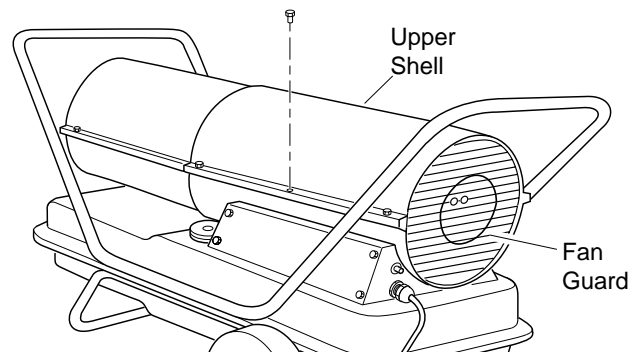

Figure 6 - Upper Shell Removal

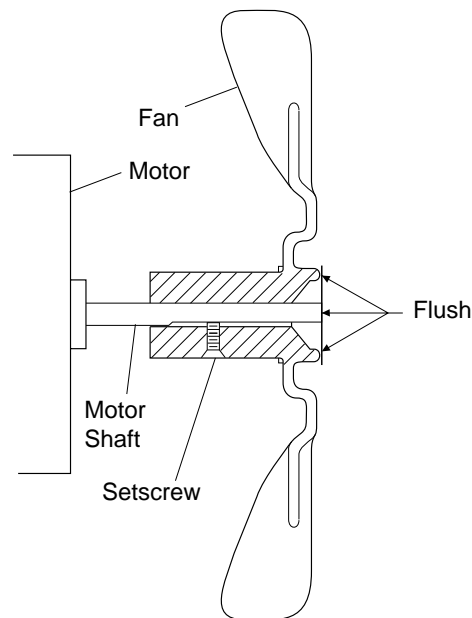

Figure 7 - Fan Cross Section

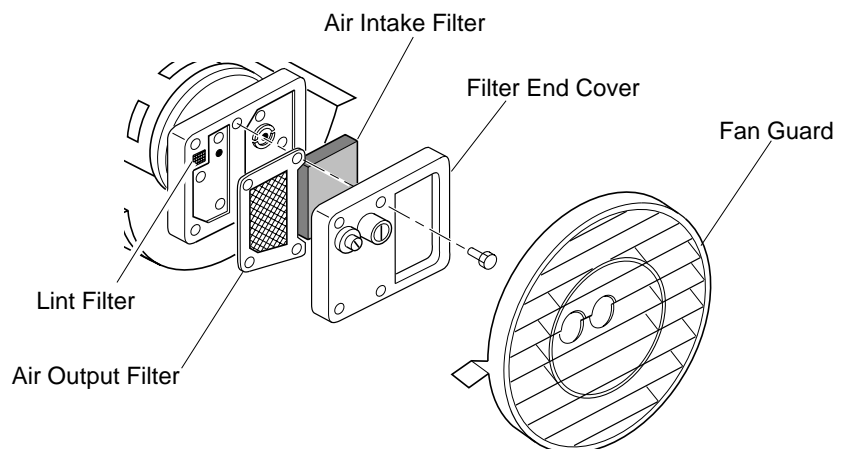
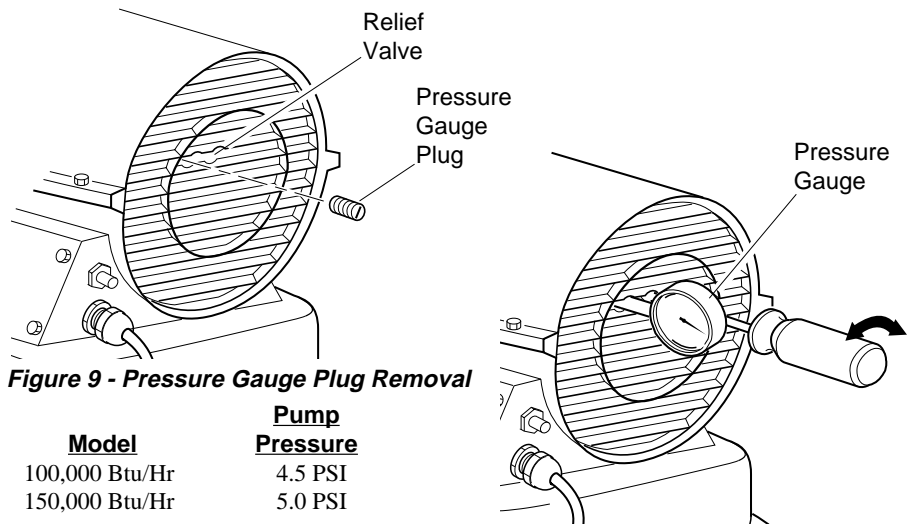

Figure 8 - Air Output, Air Intake, and Lint Filters

Pump Pressure Adjustment

1. Remove pressure gauge plug from filter end cover.
2. Install accessory pressure gauge (part number HA1180).
3. Start heater (see Operation, page 7). Allow motor to reach full speed.
4. Adjust pressure. Turn relief valve to right to increase pressure. Turn relief valve to left to decrease pressure. See specifications at right for correct pressure for each model.
5. Remove pressure gauge. Replace pressure gauge plug in filter end cover.



Fuel Filter

1. Remove side cover screws using 5/16" nut-driver.
2. Remove side cover.
3. Pull upper fuel line off fuel filter neck.
4. Carefully pry bushing, fuel filter, and lower fuel line out of fuel tank.
5. Wash fuel filter with clean fuel and replace in tank.
6. Attach upper fuel line to fuel filter neck.
7. Replace side cover.

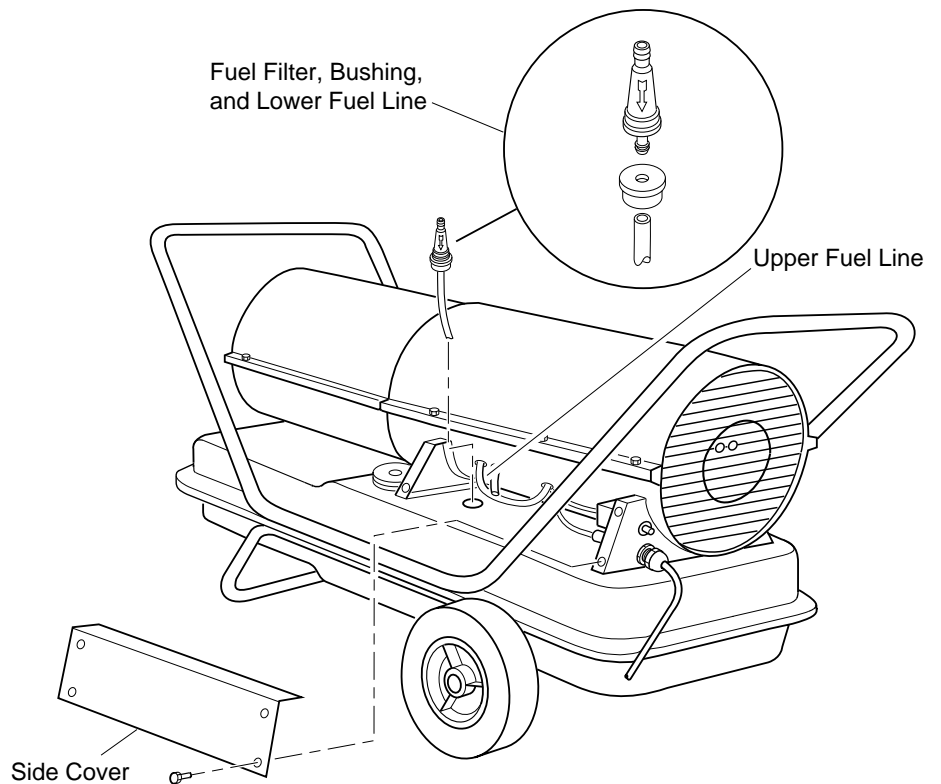

Spark Plug

1. Remove upper shell (see page 10).
2. Remove fan (see page 10).
3. Remove spark plug wire from spark plug.
4. Remove spark plug from burner head using 13/16" open-end wrench.
5. Clean and regap spark plug electrodes to .075" gap.
6. Install spark plug in burner head.
7. Attach spark plug wire to spark plug.
8. Replace fan (see page 10).
9. Replace fan guard and upper shell.

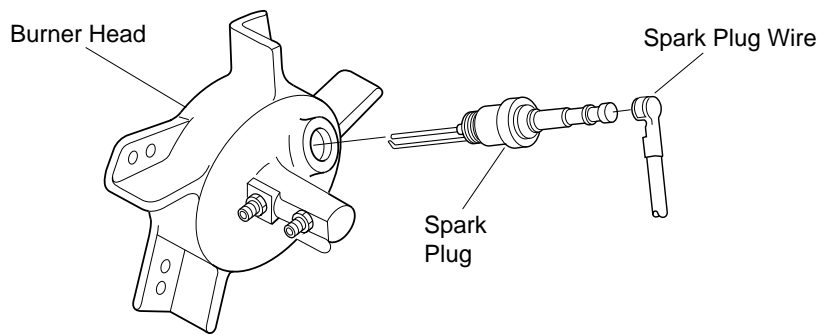

Figure 12 - Spark Plug Removal

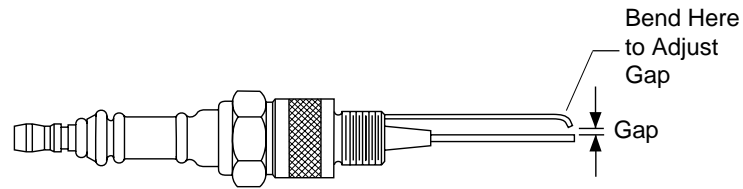

Figure 13 - Spark Plug Gap

Nozzle

1. Remove upper shell (see page 10).
2. Remove fan (see page 10).
3. Remove fuel and air line hoses from burner head.
4. Remove spark plug wire from spark plug.
5. Remove spark plug from burner head using 13/16" open-end wrench.
6. Remove three screws using 5/16" nut-driver and remove burner head from combustion chamber.
7. Place burner head into vise and lightly tighten.
8. Carefully remove nozzle from burner head using 5/8" socket wrench (see Figure 14).
9. Blow compressed air through face of nozzle. This will free any dirt in nozzle area.
10. Inspect nozzle seal for damage.
11. Replace nozzle into burner head and tighten firmly (9.1-12.4 n-m /80-110 inch-pounds).
12. Attach burner head to combustion chamber.
13. Install spark plug in burner head.
14. Attach spark plug wire to spark plug.
15. Attach fuel and airline hoses to burner head.
16. Replace fan (see page 10).
17. Replace fan guard and upper shell.

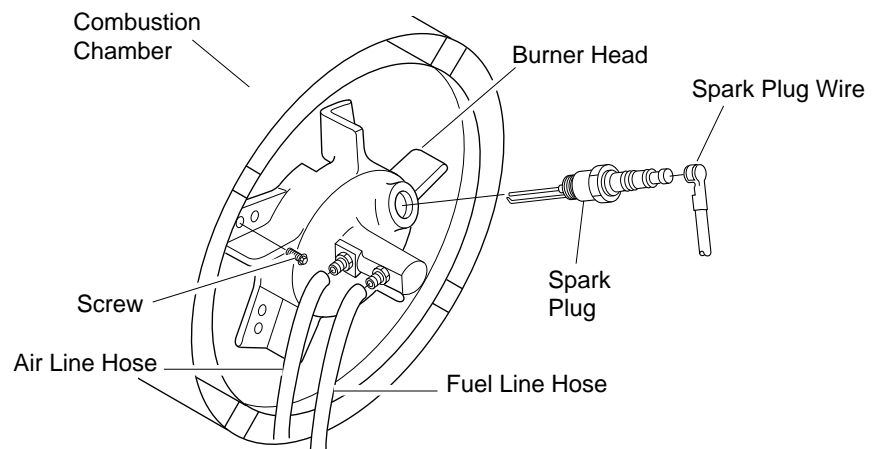

Figure 14 - Removing Burner Head

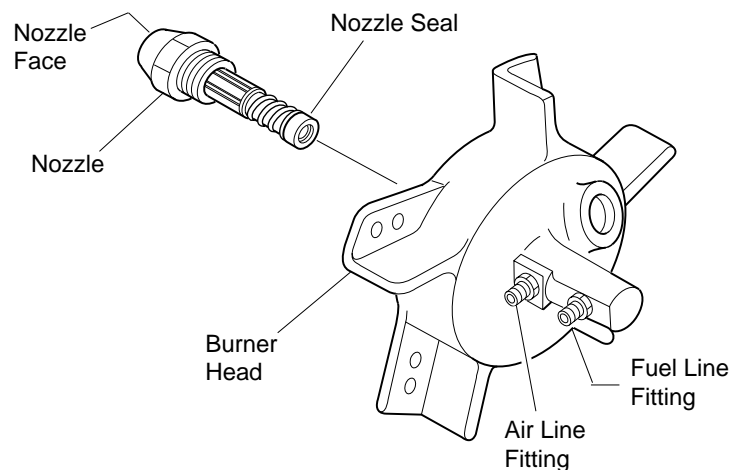

Figure 15- Removing Nozzle

Pump Rotor

(Procedure if rotor is binding)

1. Remove upper shell (see page 10).
2. Remove filter end cover screws using 5/16" nut-driver.
3. Remove filter end cover and air filters.
4. Remove pump plate screws using 5/16" nut-driver.
5. Remove pump plate.
6. Remove rotor, insert, and blades.
7. Check for debris in pump. If debris is found, blow out with compressed air.
8. Install insert and rotor.
9. Check gap on rotor. Adjust to .076/.101 mm (.003"/.004") if needed (see Figure 17).

Note: Rotate rotor one full turn to insure the gap is .076/.101 mm (.003"/.004") at tightest position. Adjust if needed.

10. Install blades, pump plate, air filters, and filter end cover.
11. Replace fan guard and upper shell.
12. Adjust pump pressure (see page 11).

Note: If rotor is still binding, proceed as follows.

13. Perform steps 1 through 6 above.
14. Place fine grade sandpaper (600 grit) on flat surface. Sand rotor lightly in "figure 8" motion four times (see Figure 18).
15. Reinstall insert and rotor.
16. Perform steps 10 through 12 above.

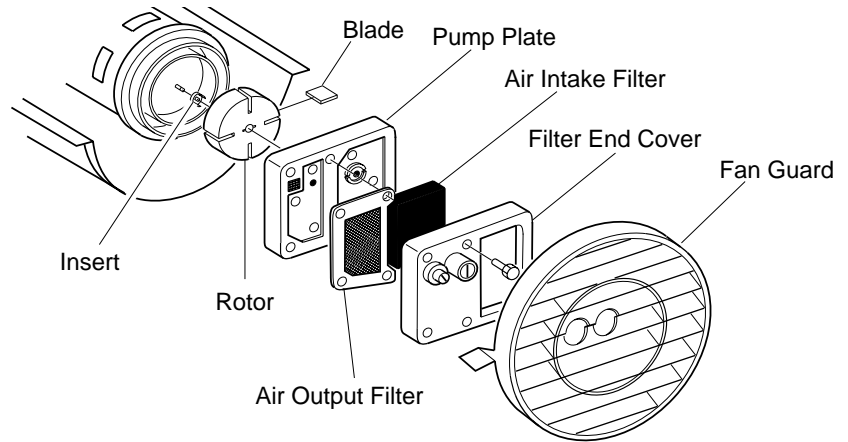

Figure 16 - Rotor Location

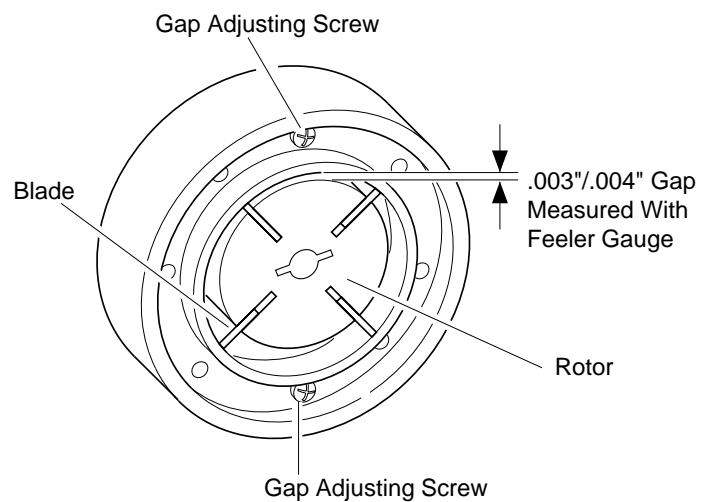

Figure 17 - Gap Adjusting Screw Locations

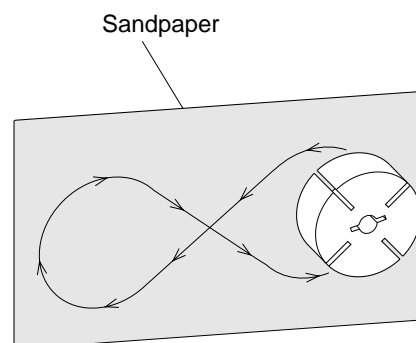
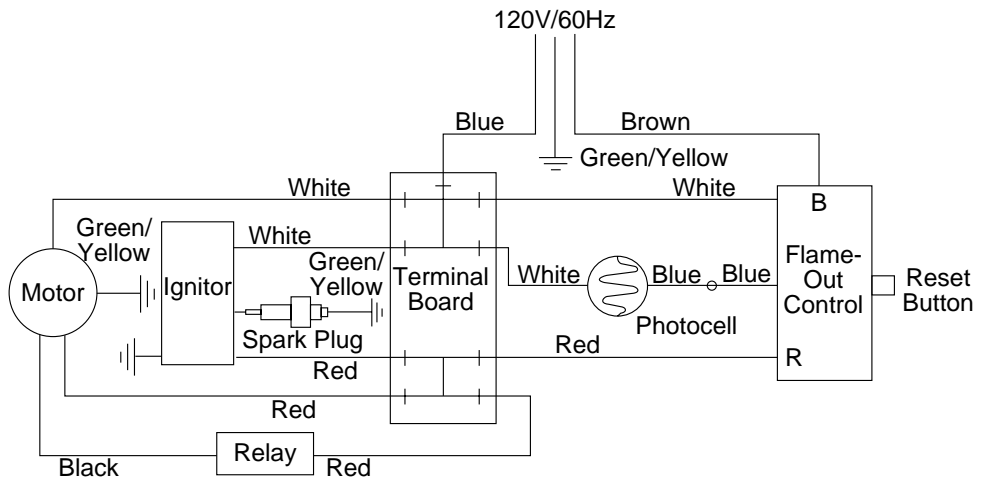

Figure 18 - Sanding Rotor

SPECIFICATIONS

Output Rating (Btu/Hr.)	100,000	150,000
Fuel	Use Only Kerosene or No. 1 Fuel Oil	
Fuel Tank Capacity (Liters/U.S. Gal.)	34/9.0	51/13.5
Fuel Consumption (Liters/Gal. Per Hr.)	2.8/1.1	4.1/1.1
Electric Requirements	120 V/60 Hz (Same All Models)	
Amperage (Normal Run)	4.0	4.4
Hot Air Output (CMM/CFM)	13.6/480	14.2/500
Motor RPM	3450	3450
Motor HP	1/4	1/4
Approximate Shipping Weight (KG/Pounds)	27/60	31/68
Approximate Heater Weight without Fuel (KG/Pounds)	23/51	26/57

WIRING DIAGRAM



REPLACEMENT PARTS AND ACCESSORY

Purchase accessories and parts from your local dealer.

AIR GAUGE KIT - HA1180
Special tool to check pump pressure.

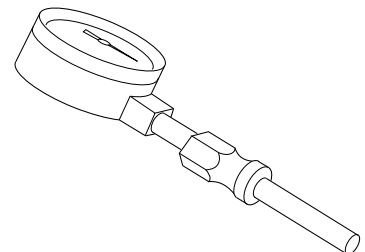

WHEELS AND HANDLE PARTS LIST

KEY NO.	PART NUMBER	PART DESCRIPTION	BY100ECA 100,000 QTY.	BY150ECA 150,000 QTY.
1	HA2203	Handle	2	—
	HA2204	Handles	—	2
2	M12345-33	Screw, #10-24 x 1 3/4"	8	8
3	M12342-3	Wheel Support Frame	1	—
	M12831-3	Wheel Support Frame	—	1
4	NTC-3C	Hex Nut, #10-24	8	8
5	097896-04	Wheel	2	2
6	M28526	Cap Nut	2	2
7	M51015-01	Axle	1	—
	M16801-2	Axle	—	1

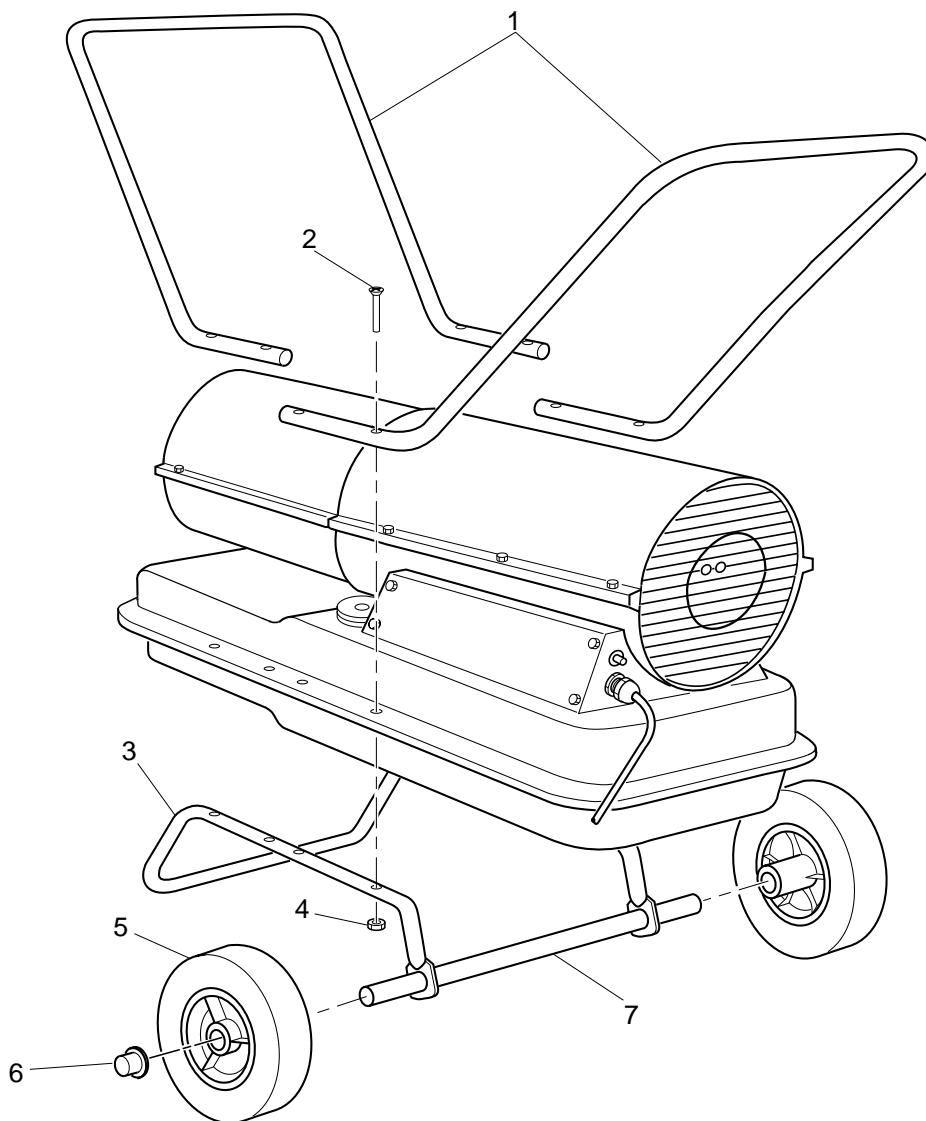

Model BY100ECA, 100,000 Btu/Hr and Model BY150ECA, 150,000 Btu/Hr

ILLUSTRATED PARTS BREAKDOWN

100,000 Btu/Hr
Model BY100ECA

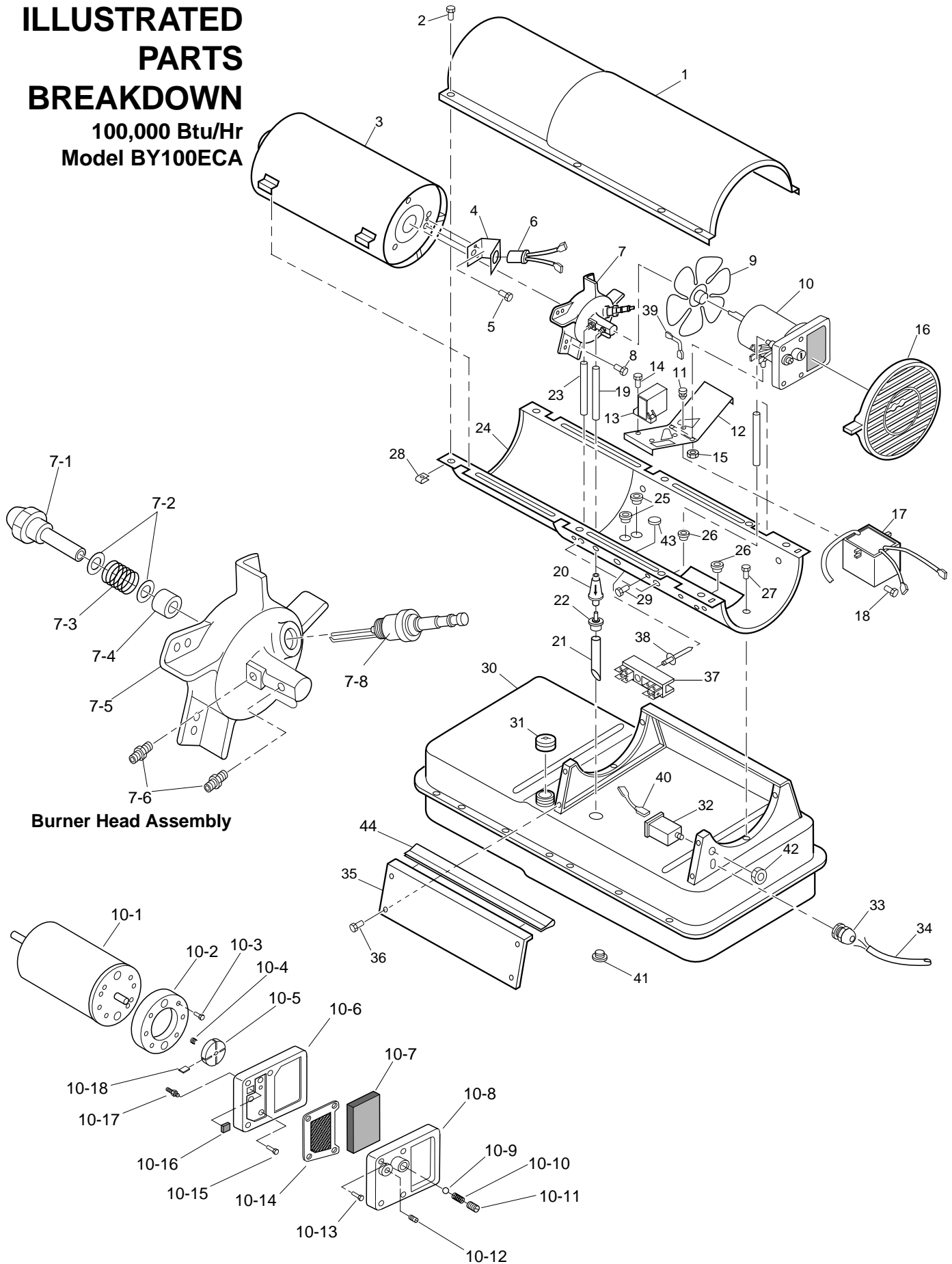

Burner Head Assembly

Motor and Pump Assembly

PARTS LIST

100,000 Btu/Hr Model BY100ECA

This list contains replaceable parts used in your heater. When ordering parts, be sure to provide the correct model and serial numbers (from the model plate), then the part number and description of the desired part.

KEY NO.	PART NUMBER	DESCRIPTION	QTY.	KEY NO.	PART NUMBER	DESCRIPTION	QTY.
1	098511-138	Upper Shell	1	17	102482-01	Ignitor Kit	1
2	100647-01	Screw, #10-16 x 1/2"	8	18	M11084-29	Screw, #10-16 x 3/4"	2
3	098512-31	Combustion Chamber	1	19	M51345-01	Fuel Line	1
4	M16660	Photocell Bracket	1	20	M51150-01	Fuel Filter	1
5	M10908-2	Screw, #6-32 x 3/8"	2	21	M51151-01	Fuel Line Tube	1
6	HA3019	Photocell Assembly	1	22	M10990-3	Rubber Bushing	1
7	**	Burner Head Assembly	1	23	M50814-03	Airline	1
7-1	100735-06	Nozzle	1	24	098511-191	Lower Shell	1
7-2	M10659-1	Nozzle Washer	2	25	M50104-03	Bushing	2
7-3	M10809-1	Nozzle Spring	1	26	M50104-01	Bushing	2
7-4	M8882	Nozzle Sleeve	1	27	M11084-27	Screw, #10-16 x 1/2"	6
7-5	M50924-03	Burner Head Body	1	28	M11271-8	Clip Nut	8
7-6	M50820-02	Barb Fitting	2	29	M10908-14	Screw, #8-32 x 3/8"	1
7-7	HA3012	Spark Plug	1	30	098513-75	Fuel Tank	1
8	M11084-27	Screw, #10-16 x 1/2"	3	31	097702-01	Fuel Cap (Includes Gasket)	1
9	097293-01	Fan	1	32	HA3003	Flame-Out Control	1
10	**	Motor and Pump Assembly	1	33	M50400	Strain Relief Bushing	1
10-1	102001-06	Motor (Split Phase)	1	34	M15779-27	Power Cord	1
10-2	079975-02	Pump Body	1	35	M51077-01AA	Side Cover	1
10-3	FHPF3-5C	Screw, #10-32 x 5/8"	2	36	M11084-27	Screw, #10-16 x 1/2"	4
10-4	M22009	Rotor Insert	1	37	099125-03	Terminal Board	1
10-5	M22456-1	Pump Rotor	1	38	099157-01	Rivet	1
10-6	M50545	Pump End Cover	1	39	079010-20	Wire Assembly (Red, 18")	1
10-7	M12179	Intake Filter	1	40	M16841-57	Wire Assembly (Red, 6")	1
10-8	M16545	Filter End Cover	1	41	M27417	Drain Plug (Includes "o" Ring)	1
10-9	M8940	Steel Ball, 1/4" Diameter	1	42	099177-01	Hex Nut, 3/8 - 27	1
10-10	M10993-1	Relief Spring	1	43	099213-01	Button Plug	1
10-11	M27694	Adjusting Screw	1	44	097468-01	Edge Liner	1
10-12	M22997	Plug	1	PARTS AVAILABLE - NOT SHOWN			
10-13	M12461-31	Screw, #10-32 x 1"	10				
10-14	M12244-1	Output Filter	1				
10-15	M11637	Lint Filter	1		097650-01	Tradename Decal	1
10-16	M50820-02	Barb Fitting	1		101888-21	Operation Decal (English/French)	1
10-17	M8643	Blade	4		101888-20	Operation Decal (Spanish/Dutch)	1
11	M50631	Rubber Bumper	2		101639-04	Warning Decal	1
12	101206-01	Motor Mounting Bracket	1		HA2210	Filler Neck Screen	1
13	097061-01	Solid State Relay	1		M9900-192	Combustion Chamber	
14	M15823-39	Screw, #8-18 x 1/2"	2			Grounding Wire	1
15	NTC-4C	Hex Lock Nut, 1/4-20	2				
16	M51114-01	Fan Guard	1				

** Not available as an assembly.

ILLUSTRATED PARTS BREAKDOWN

150,000 Btu/Hr
Model BY150ECA

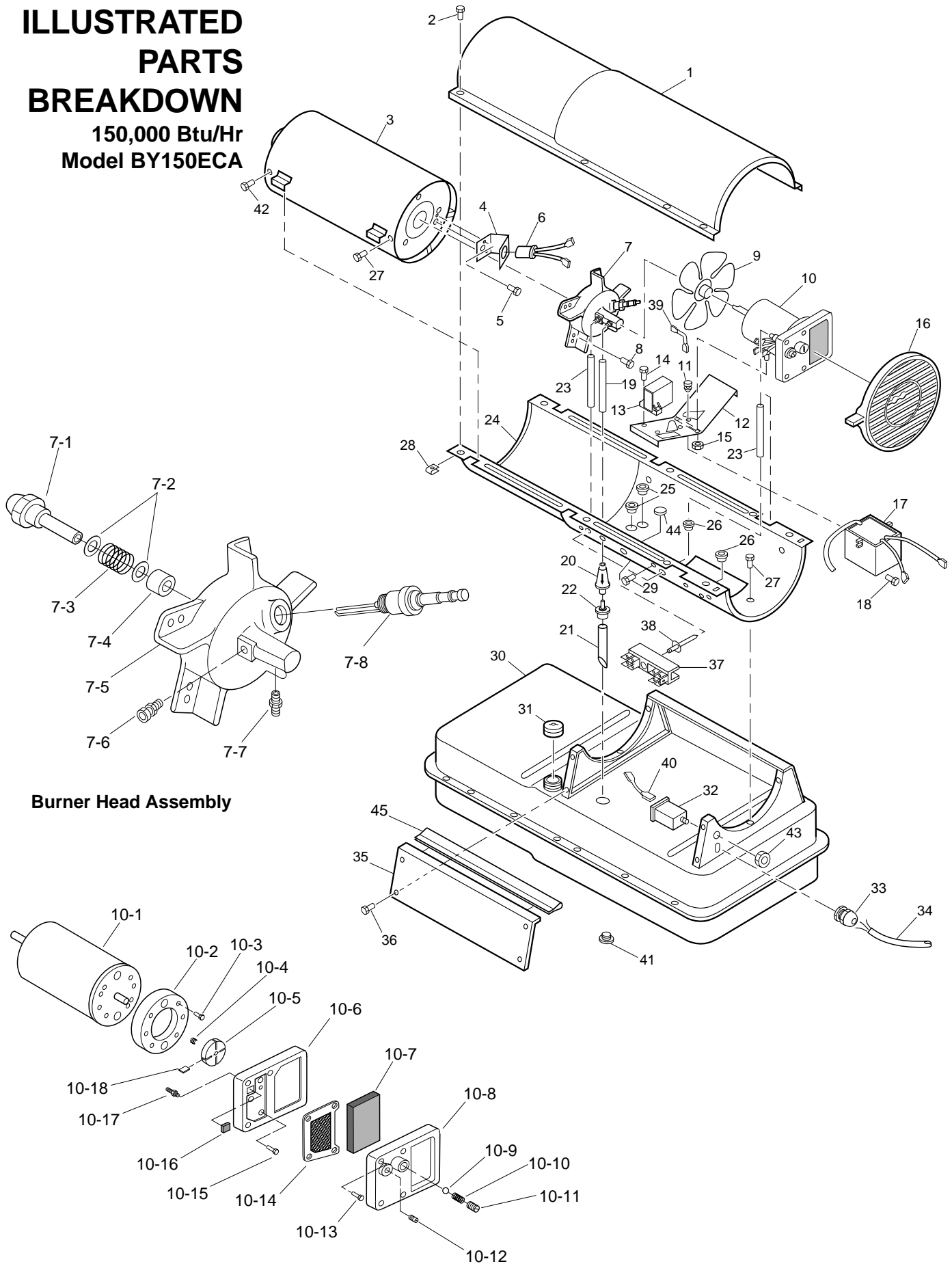

Burner Head Assembly

Motor and Pump Assembly

PARTS LIST

150,000 Btu/Hr BY150ECA

This list contains replaceable parts used in your heater. When ordering parts, be sure to provide the correct model and serial numbers (from the model plate), then the part number and description of the desired part.

KEY NO.	PART NUMBER	DESCRIPTION	QTY.	KEY NO.	PART NUMBER	DESCRIPTION	QTY.
1	098511-138	Upper Shell	1	17	102482-01	Ignitor Kit	1
2	100647-01	Screw, #10-16 x 1/2"	8	18	M11084-29	Screw, #10-16 x 3/4"	2
3	098512-29	Combustion Chamber	1	19	M51345-01	Fuel Line	1
4	099229-01	Photocell Bracket	1	20	M51150-01**	Fuel Filter	1
5	M10908-2	Screw, #6-32 x 3/8"	2	21	M51151-02	Fuel Line Tube	1
6	HA3019	Photocell Assembly	1	22	M10990-3	Rubber Bushing	1
7	***	Burner Head Assembly	1	23	M50814-03	Airline	1
7-1	100735-07	Nozzle	1	24	098511-191	Lower Shell	1
7-2	M10659-1	Nozzle Washer	2	25	M50104-03	Bushing	2
7-3	M10809-1	Nozzle Spring	1	26	M50104-01	Bushing	2
7-4	M8882	Nozzle Sleeve	1	27	M11084-27	Screw, #10-16 x 1/2"	8
7-5	M50924-03	Burner Head Body	1	28	M11271-8	Clip Nut	8
7-6	M50820-02	Barb Fitting	2	29	M10908-14	Screw, #8-32 x 3/8"	1
7-7	HA3012	Spark Plug	1	30	098513-76	Fuel Tank	1
8	M11084-27	Screw, #10-16 x 1/2"	3	31	097702-01	Fuel Cap (Includes Gasket)	1
9	097293-01	Fan	1	32	HA3003	Flame-out Control	1
10	***	Motor and Pump Assembly	1	33	M50400	Strain Relief Bushing	1
10-1	102001-06	Motor (Split Phase)	1	34	098219-19	Power Cord	1
10-2	079975-02	Pump Body	1	35	M51077-01AA	Side Cover	1
10-3	FHPF3-5C	Screw, #10-32 x 5/8"	2	36	M11084-27	Screw, #10-16 x 1/2"	4
10-4	M22009**	Rotor Insert	1	37	099125-03	Terminal Board	1
10-5	M22456-1**	Pump Rotor	1	38	099157-01	Rivet	1
10-6	M50545	Pump End Cover	1	39	079010-20	Wire Assembly (Red, 18")	1
10-7	M12179**	Intake Filter	1	40	M16841-57	Wire Assembly (Red, 6")	1
10-8	M16545	Filter End Cover	1	41	M27417	Drain Plug (Includes "O" Ring)	1
10-9	M8940**	Steel Ball, 1/4" diameter	1	42	099230-01	Shoulder Screw	2
10-10	M10993-1**	Relief Spring	1	43	099177-01	Hex Nut, 3/8-27	1
10-11	M27694**	Adjusting Screw	1	44	099213-01	Button Plug	1
10-12	M22997**	Plug	1	45	097468-01	Edge Liner	1
10-13	M12461-31	Screw, #10-32 x 1"	10	PARTS AVAILABLE - NOT SHOWN			
10-14	M12244-1**	Output Filter	1				
10-15	M11637**	Lint Filter	1		HA2210	Filler Neck Screw	1
10-16	M50820-02	Barb Fitting	1		097643-01	Tradename Decal	1
10-17	M8643**	Blade	4		101888-22	Operation Decal (English/French)	1
11	M50631	Rubber Bumper	2		101888-23	Operation Decal (Spanish/Dutch)	1
12	101206-01	Motor Mounting Bracket	1		101639-04	Warning Decal	1
13	097061-01	Solid State Relay	1		M9900-192	Combustion Chamber Grounding Wire	1
14	M15823-39	Screw, #8-18 x 1/2"	2				
15	NTC-4C	Hex Lock Nut, 1/4-20	2				
16	M51114-01	Fan Guard	1				

** Not available as an assembly.

**EC
CONFORMITY
DECLARATION**

EC CONFORMITY DECLARATION

**DESA Europe B.V.
Industrieweg 167, 3044 AS
Postbus 11158
3004 ED Rotterdam
Holland**

**Manufacturer:
DESA International, Inc.
2701 Industrial Drive
Bowling Green, KY 42101 U.S.A.**

**Kerosene Portable Forced Air Heaters
Model Numbers: BY100ECA and BY150ECA**

It is declared that these models conform to the Machinery Directive 89/392/EEC, including 91/368/EEC, 93/68/EEC.

We declare that the models noted are in conformity.

<u>Company</u>	<u>DESA International, Inc.</u>
<u>Name</u>	<u>Douglas D. Rohrer</u>
<u>Title</u>	<u>Vice President, Specialty Products Engineering</u>

07/04/95 — Bowling Green, KY

Date and Place

Signature

WARRANTY AND REPAIR SERVICE

DESA International warrants new Products sold by it to be free from defects in material or workmanship for a period of 360 days after date of delivery to the first user and subject to the following conditions:

DESA International's obligation and liability under this Warranty is expressly limited to repairing or replacing at DESA International's option, any parts which appear to DESA International upon inspection to have been defective in material or workmanship when shipped from the factory. Such parts shall be provided at no cost to the user, at the business establishment of any factory authorized service center or the factory during regular working hours. The Warranty shall not apply to component parts or accessories of Products not manufactured by DESA International and which carry the warranty of the manufacturer thereof, or to normal maintenance (such as pressure adjustments) or to normal maintenance parts (such as filters and spark plugs). Replacement or repair parts installed in the Product covered by this Warranty are warranted only for the remainder of this Warranty as if such parts were original components of said Product. DESA INTERNATIONAL MAKES NO OTHER EXPRESS WARRANTY. TO THE EXTENT PERMITTED BY LAW DESA INTERNATIONAL MAKES NO IMPLIED WARRANTY AND MAKES NO WARRANTY OF MERCHANTABILITY OR FITNESS FOR ANY

PARTICULAR PURPOSE. IN ANY EVENT IMPLIED WARRANTIES INCLUDING THOSE OF MERCHANTABILITY AND FITNESS FOR A PARTICULAR PURPOSE ARE LIMITED TO THE DURATION OF THIS EXPRESS WARRANTY.

Any transportation charges, costs of installation, duty, taxes or any other charges whatsoever must be borne by the user. DESA International's obligation under this limited Warranty shall not include any liability for direct, indirect, incidental, or consequential damage or delay. If requested by DESA International, Products or parts for which a warranty claim is made are to be returned transportation prepaid by user to the factory. Any improper use, including operation after discovery of defective or worn parts, operation beyond capacity, substitution of parts not approved by DESA International, or any alteration or repair by others in such manner as in DESA International's judgement affects the Product materially and adversely, shall void this Warranty.

NO EMPLOYEE OR REPRESENTATIVE IS AUTHORIZED TO CHANGE THIS WARRANTY IN ANY WAY OR GRANT ANY OTHER WARRANTY UNLESS SUCH CHANGE IS MADE IN WRITING AND SIGNED BY AN OFFICER OF DESA INTERNATIONAL AT ITS HOME OFFICE.

WARRANTY SERVICE

Always specify model and serial numbers when communicating with the factory.

We reserve the right to amend these specifications at any time without notice. The only Warranty applicable is our standard written Warranty. We make no other Warranty, expressed or implied.

A Service Manual is available by writing to the Technical Service Department at:

DESA INTERNATIONAL

Corporate Headquarters

2701 Industrial Drive

P.O. Box 90004

Bowling Green, Kentucky 42102-9004 U.S.A.

Free Manuals Download Website

<http://myh66.com>

<http://usermanuals.us>

<http://www.somanuals.com>

<http://www.4manuals.cc>

<http://www.manual-lib.com>

<http://www.404manual.com>

<http://www.luxmanual.com>

<http://aubethermostatmanual.com>

Golf course search by state

<http://golfingnear.com>

Email search by domain

<http://emailbydomain.com>

Auto manuals search

<http://auto.somanuals.com>

TV manuals search

<http://tv.somanuals.com>