

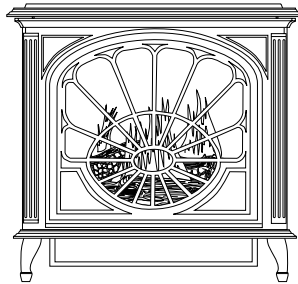

CAST IRON STOVE AND B-VENT (FREESTANDING FIREPLACE HEATER) BURNER SYSTEM

OWNER'S OPERATION AND INSTALLATION MANUAL

For more information, visit www.desatech.com



SCIVFC/PSCIVFC
SERIES STOVE
"AMITY™"

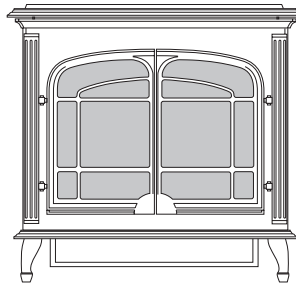

VCIS/PVCIS
Series Stove
"OXFORD™"

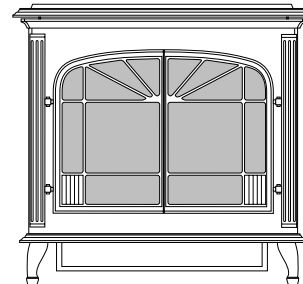

VH series Stove
"VICTOR HEARTH™"



NATURAL GAS BURNER SYSTEM SBVBN(D) PROPANE/LP GAS BURNER SYSTEM SBVBP(D) REMOTE READY

IMPORTANT: This B-vent burner system must be installed into approved DESA cast iron stove bodies, models SCIVFC, PSCIVFC, and VH series ONLY. See page 3 of this manual.

WARNING: If the information in this manual is not followed exactly, a fire or explosion may result causing property damage, personal injury, or loss of life.

FOR YOUR SAFETY

Do not store or use gasoline or other flammable vapors and liquids in the vicinity of this or any other appliance.

FOR YOUR SAFETY

WHAT TO DO IF YOU SMELL GAS

- Do not try to light any appliance.
- Do not touch any electrical switch
- Do not use any phone in your building.
- Immediately call your gas supplier from a neighbor's phone. Follow the gas supplier's instructions.
- If you cannot reach your gas supplier, call the fire department.

WARNING: Improper installation, adjustment, alteration, service, or maintenance can cause injury or property damage. Refer to this manual for correct installation and operational procedures. For assistance or additional information consult a qualified installer, service agency, or the gas supplier.

Installation and service must be performed by a qualified installer, service agency, or the gas supplier.

This appliance may be installed in an aftermarket*, permanently located, manufactured (mobile) home, where not prohibited by state or local codes.

This appliance is only for use with the type of gas indicated on the rating plate. This appliance is not convertible for use with other gases, unless a certified kit is used.

* Aftermarket: Completion of sale, not for purpose of resale, from the manufacturer.

Save this manual for future reference.



TABLE OF CONTENTS

SAFETY INFORMATION	2	INSPECTING BURNERS	21
PRODUCT IDENTIFICATION	3	CLEANING AND MAINTENANCE	22
LOCAL CODES	4	TROUBLESHOOTING	23
PRODUCT FEATURES	4	REPLACEMENT PARTS	26
PRE-INSTALLATION PREPARATION	4	TECHNICAL SERVICE	26
CAST IRON STOVE AND B-VENT BURNER		WIRING DIAGRAM	26
SYSTEM ASSEMBLY	5	SERVICE HINTS	26
VENTING INSTALLATION	9	SPECIFICATIONS	27
TROUBLESHOOTING VENTING PROBLEMS	12	ILLUSTRATED PARTS BREAKDOWN AND PARTS LIST	28
CAST IRON STOVE AND B-VENT BURNER		ACCESSORIES	32
SYSTEM INSTALLATION	12	OWNER'S REGISTRATION FORM	33
OPERATING STOVE WITH B-VENT BURNER SYSTEM	19	WARRANTY INFORMATION	Back Cover

SAFETY INFORMATION

WARNINGS

WARNING: This product contains and/or generates chemicals known to the State of California to cause cancer or birth defects, or other reproductive harm.

IMPORTANT: Read this owner's manual carefully and completely before trying to assemble, operate, or service this stove and burner system. Improper use of this stove and burner system can cause serious injury or death from burns, fire, explosions, electrical shock, and carbon monoxide poisoning.

DANGER: Carbon monoxide poisoning may lead to death!

This stove with burner system is a vented product. This stove with burner system will not produce any gas leakage into your home if properly installed. This unit must be properly installed by a qualified service person. The glass door must be properly seated and sealed. If this unit is not properly installed by a qualified service person with glass door properly seated and sealed, gas leakage can occur.

Carbon Monoxide Poisoning: Early signs of carbon monoxide poisoning resemble the flu, with headaches, dizziness, or nausea. If you have these signs, the burner system may not have been installed properly. **Get fresh air at once!** Have stove with burner system inspected and serviced by a qualified service person. Some people are more affected by carbon monoxide than others. These include pregnant women, people with heart or lung disease or anemia, those under the influence of alcohol, and those at high altitudes.

Natural and Propane/LP Gas: Natural and propane/LP gases are both odorless. An odor-making agent is added to each of these gases. The odor helps you detect a gas leak. However, the odor added to these gases can fade. Gas may be present even though no odor exists.

Make certain you read and understand all warnings. Keep this manual for reference. It is your guide to safe and proper operation of this stove with B-vent burner system.

WARNING: Any change to this stove or burner system or its controls can be dangerous.

1. This appliance is only for use with the type of gas indicated on the rating plate. This appliance is not convertible for use with other gases unless a certified kit is used.
2. For propane/LP burner system, do not place propane/LP supply tank(s) inside any structure. Locate propane/LP supply tank(s) outdoors. To prevent performance problems, do not use propane/LP fuel tank of less than 100 lbs. capacity.
3. If you smell gas
 - shut off gas supply
 - do not try to light any appliance
 - do not touch any electrical switch; do not use any phone in your building
 - immediately call your gas supplier from a neighbor's phone. Follow the gas supplier's instructions
 - if you cannot reach you gas supplier, call the fire department.
4. Never install the stove
 - in a recreational vehicle
 - where curtains, furniture, clothing, or other flammable objects are less than 42" from the front, top, or sides of the stove with burner system
 - in high traffic areas
 - in windy or drafty areas

For more information, visit www.desatech.com

SAFETY INFORMATION

Continued

5. This stove reaches high temperatures. Keep children and adults away from hot surfaces to avoid burns or clothing ignition. Stove will remain hot for a time after shut-down. Allow surfaces to cool before touching.
6. Carefully supervise young children when they are in the room with stove.
7. Do not modify this stove or burner system under any circumstances. Any parts removed for servicing must be replaced prior to operating burner system.
8. Turn burner system off and let cool before servicing, installing, or repairing. Only a qualified service person should install, service, or repair this stove or burner system. Have stove and burner system inspected annually by a qualified service person.
9. You must keep control compartments, burners, and circulating air passages clean. More frequent cleaning may be needed due to excessive lint and dust from carpeting, bedding material, pet hair, etc. Turn off the gas valve and pilot light before cleaning stove or burner system.
10. Have venting system inspected annually by a qualified service person. If needed, have venting system cleaned or repaired. See *Cleaning and Maintenance*, page 22.
11. Keep the area around your stove clear of combustible materials, gasoline, and other flammable vapor and liquids. Do not run burner system where these are used or stored. Do not place items such as clothing or decorations on or around stove.
12. Do not use this stove to cook food or burn paper or other objects.
13. Never place anything on top of stove.
14. Do not use any solid fuels (wood, coal, paper, cardboard, etc.) in this burner system. Use only the gas type indicated on burner system nameplate.
15. This appliance, when installed, must be electrically grounded in accordance with local codes or, in the absence of local codes, with the *National Electrical Code, ANSI/NFPA 70*, or the *Canadian Electrical Code, CSA C22.1*.
16. Do not obstruct the flow of combustion and ventilation air in any way. Provide adequate clearances around air openings into the combustion chamber along with adequate accessibility clearance for servicing and proper operation.
17. Do not install stove with burner system directly on carpeting, vinyl tile, or any combustible material other than wood. The stove must set on a metal or wood panel extending the full width and depth of the stove.
18. Do not use stove or burner system if any part has been exposed to or under water. Immediately call a qualified service person to arrange for replacement of the unit.
19. Do not operate burner system if any log is broken.
20. Do not use a blower insert, heat exchanger insert, or other accessory not approved for use with this stove.
21. Do not operate burner system with glass door removed, cracked, or broken.
22. This heater must be properly connected to a vent system. This heater is equipped with a vent safety shutoff system.
23. Provide adequate clearances to air openings.

PRODUCT IDENTIFICATION

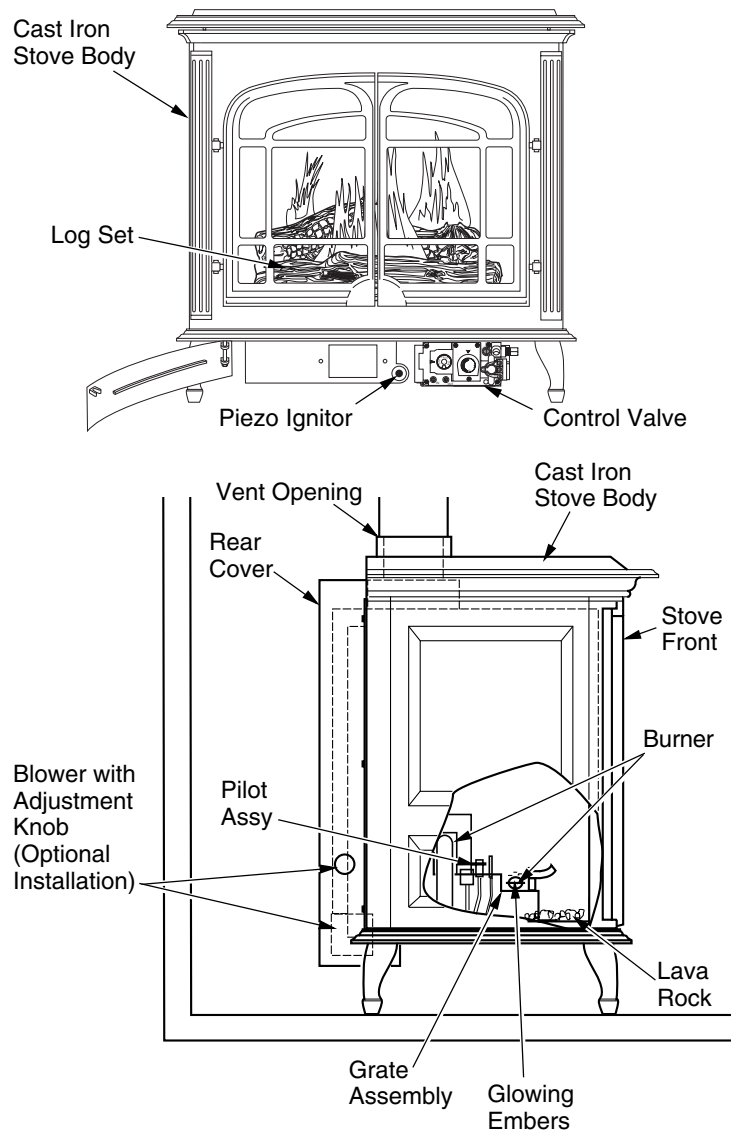

Figure 1 - DESA B-Vent Burner System Shown Installed in Approved DESA Cast Iron Stove Body Models SCIVFC, PSCIVFC, VCIS, PVCIS and VH Series Only (Oxford™ Model Shown)

LOCAL CODES

Install and use stove and burner system with care. Follow all local codes. In the absence to local codes, use the current *National Fuel Gas Code ANSI Z223.1/NFPA 54** (USA) or the current *CAN/CGA-B149[.1 or .2] Installation Codes* (Canada).

*Available from:

American National Standards Institute, Inc.
1430 Broadway
New York, NY 10018

National Fire Protection Association, Inc.
Batterymarch Park
Quincy, MA 02269

PRODUCT FEATURES

OPERATION

This B-vent cast iron stove with burner system is clean burning and vents vertically. Heat is generated by both realistic flames and glowing embers. When used without the blower accessory, the stove with burner system requires no electricity making it ideal for emergency backup heat.

PIEZO IGNITOR

This burner system has a piezo ignitor. This system requires no matches, batteries, or other sources to light burner system.

PRE-INSTALLATION PREPARATION

WARNING: A qualified installer or service person must install stove and burner system. Follow all local codes.

CAUTION: This stove with burner system creates warm air currents. These currents move heat to wall surfaces next to stove. Installing stove next to vinyl or cloth wall coverings or operating stove with burner system where impurities (such as, but not limited to, tobacco smoke, aromatic candles, cleaning fluids, oil or kerosene lamps, etc.) in the air exist, may discolor walls or cause odors.

LOCATION AND SPACE REQUIREMENTS

Determine the safest and most efficient location for your DESA B-vent cast iron stove. Make sure that rafters and wall studs are not in the way of the venting system. Choose a location where the heat output is not affected by drafts, air conditioning ducts, windows, or doors. Figure 2 shows some common locations. Read all venting information in this manual. Be aware of all restrictions and precautions before deciding the exact location for your stove.

When deciding the location of your stove, follow these rules:

1. Do not connect this stove and burner system to a chimney flue serving a separate solid-fuel burning fireplace or appliance.
2. Due to high temperatures, do not locate this stove in high traffic areas or near furniture or draperies.
3. Proper clearances must be maintained, see Figure 3 below and Figure 4 on page 5.
4. This stove is a freestanding unit designed to set directly on the floor. If your stove is to be installed directly on carpeting, vinyl tile, or any combustible material other than wood, it must be installed on a metal or wood panel extending the full width and depth of the stove. See Figure 5, page 5.

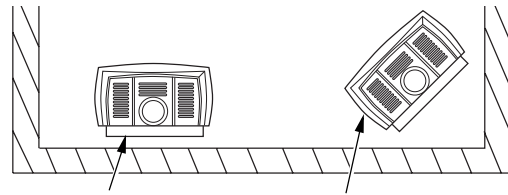

On Wall with Vertical Termination Through Ceiling Corner Installation with Vertical Termination Through Ceiling

Figure 2 - Common Stove Locations

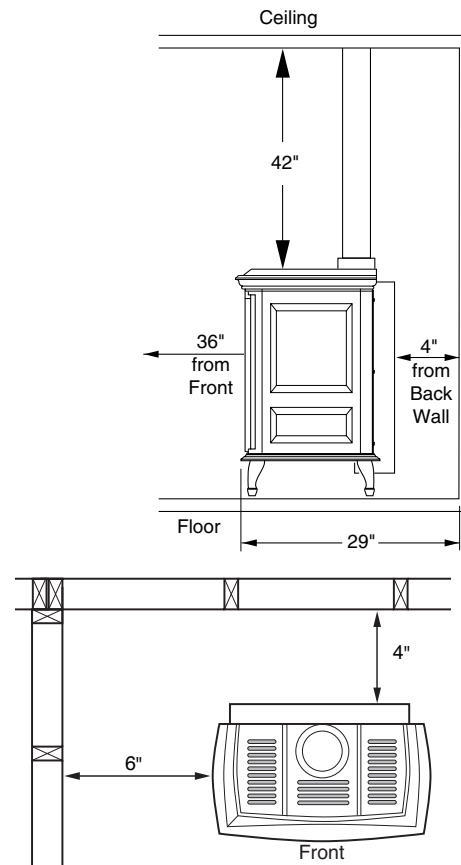

Figure 3 - Clearances for Standard Installation

PRE-INSTALLATION PREPARATION

Continued

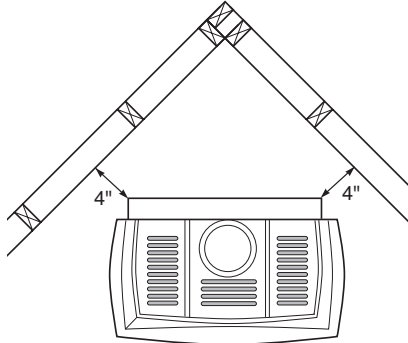

Figure 4 - Clearance for Corner Installation

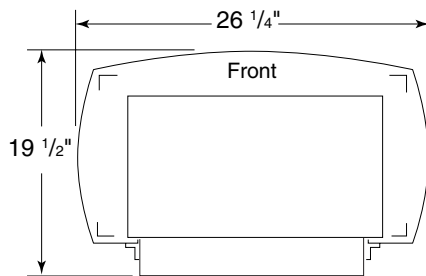

Figure 5 - Stove With Burner System Bottom Dimensions

CAST IRON STOVE AND B-VENT BURNER SYSTEM ASSEMBLY

STOVE BODY ASSEMBLY

1. Lift off corrugated box enclosing stove body crating.
2. Remove all screws fastening the wood frame enclosure. Spread wood frame open and lift away from plastic-bagged stove body. The bottom pieces of pallet wood will remain bolted to the stove body.
3. Remove plastic bag from stove body.
4. Locate the product identification label on the carton and record the model number and 7 digit serial number in the space provided in the back of this owner's manual. Retain this operation and installation manual for future reference and warranty.
5. **Amity Only:** Remove back panel from stove and discard (see Figure 6). Use an adjustable wrench or a 10 mm socket. Remove six (6) bolts and washers. Keep bolts and washers to reattach rear cover.
6. Remove all contents from inside stove cavity. Contents include:
 - (1) - Stove bottom [Amity Only] (**Discard - Not used with this application**)
 - (4) - Legs with leg leveler bolts
 - (1) - Bottom door
 - (3) - Top grates
 - (1) - Hardware kit bag with fasteners

7. Carefully lay stove body on back to attach bottom components to stove body (see Figure 7). Rest stove on drop cloth or blanket to avoid scratching stove edges.
8. Remove remaining pallet wood attached to bottom of stove body (see Figure 8). Use an adjustable wrench to remove bolts.
9. Fasten each leg to stove with four (4) M8 x 1.25 - 20mm bolts. Use a flat washer and lock washer with each bolt. Tighten bolts into threaded holes on stove body (see Figure 9 and Figure 10 on page 6). Use an adjustable wrench or a 12mm socket.

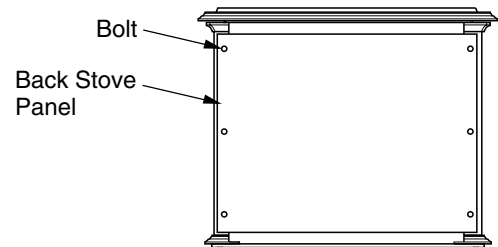

Figure 6 - Removing Back Panel (Amity™ Only)

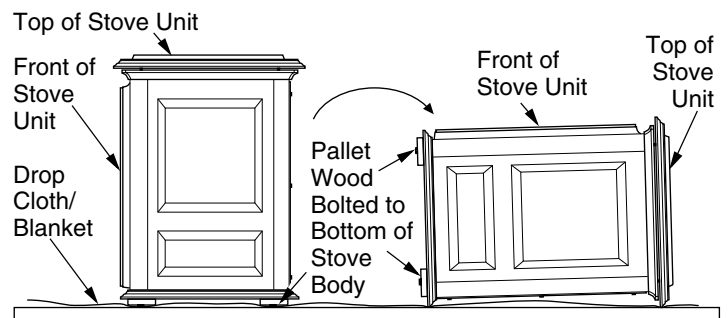

Figure 7 - Laying Down Stove On Side

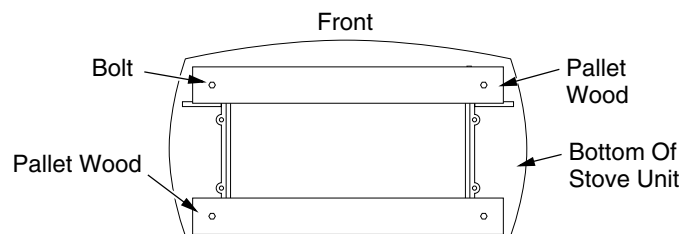

Figure 8 - Removing Pallet Wood From The Bottom of The Stove

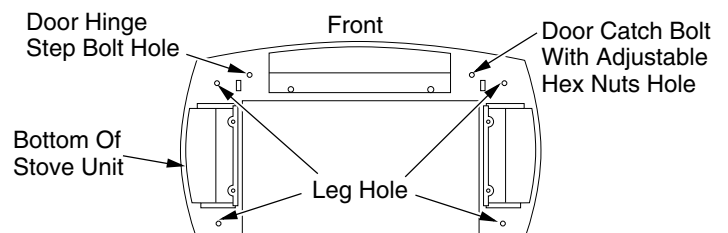

Figure 9 - Locating Threaded Holes for Legs and Door Attachment

CAST IRON STOVE AND B-VENT BURNER SYSTEM ASSEMBLY

Continued

- Attach stove door by inserting step bolt through door hinge pivot hole and into threaded hole in stove body (see Figure 11 and Figure 9 on page 5). Use an adjustable wrench or a 12mm socket to fasten step bolt. Tighten step bolt until snug. Make sure door moves freely.
- Install door catch bolt (M8 x 1.25-55mm with two M8 hex nuts) into threaded hole on stove body (see Figure 9, page 5). Use an adjustable wrench or a 12mm socket. The catch bolt has two hex nuts attached to it (see Figure 12). The top nut is a bolt stop and the bottom nut is for door leveling adjustment.
- Check general catch bolt alignment with door claw. Make final adjustment and door leveling after stove is in normal standing position.
- Carefully lift stove back up on its four attached legs.

Removing Front Surround Panel

Remove 2 bolts from bottom of stove and set aside. Remove bolt from the top of the stove to remove the front panel assembly (see Figure 13).

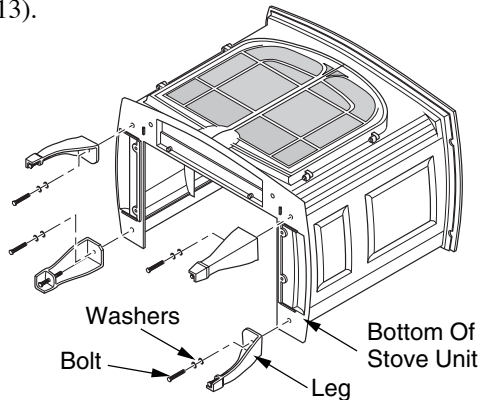

Figure 10 - Attaching Stove Legs (Oxford™ Model Shown)

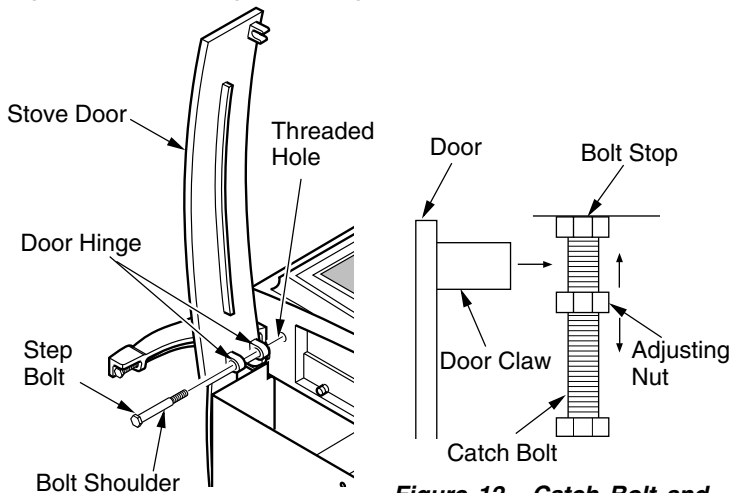

Figure 11 - Attaching Stove Door

Figure 12 - Catch Bolt and Door Claw Orientation

Removing Screen (Optional)

Amity Models

- Lay the front panel assembly face down on a protected surface. Remove the two screws that hold the front plate onto the front surround plate (see Figure 14). Save these screws.
- Remove the screws and washers that hold the screen onto the front surround plate. Discard these screws, washers, and screen (see Figure 14).
- Replace the two screws from step 1 to reassemble the front plate and the front surround plate. Set this assembly aside until burner system has been installed, logs have been placed inside of burner system, and glass door to burner system insert has been replaced.

Oxford or Victor Hearth Models

- Lay the front panel assembly face down on a protected surface. Remove the screws and washers that hold the screen onto the front surround plate. Discard these screws, washers, and screen (see Figure 14).
- Set this assembly aside until burner system has been installed, logs have been placed inside of burner system, and glass door to burner system insert has been replaced.

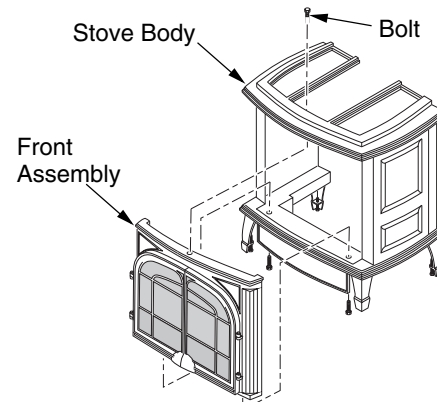

Figure 13 - Removing Front Assembly (Oxford™ Model Shown)

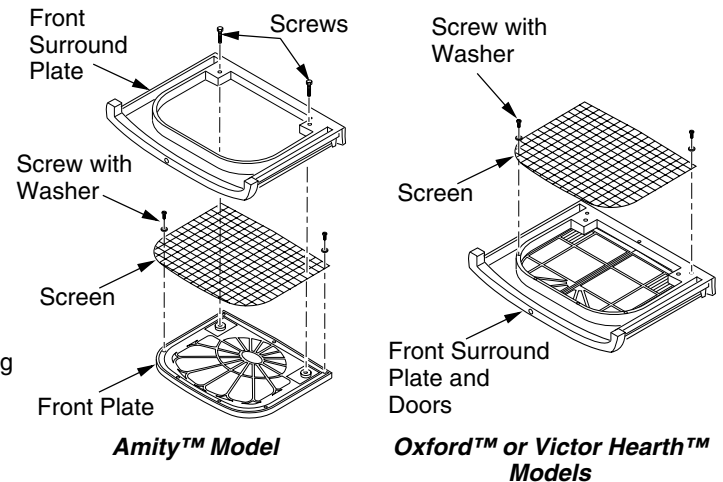

Figure 14 - Removing Screen from Front Assembly

For more information, visit www.desatech.com

CAST IRON STOVE AND B-VENT BURNER SYSTEM ASSEMBLY

Continued

INSTALLING B-VENT BURNER SYSTEM INTO STOVE BODY

1. Carefully lift burner system and place into stove body from the rear of stove.
2. Place the left and right grate tops into the top of stove body. Discard center grate top of stove and replace with center grate top provided with burner system.

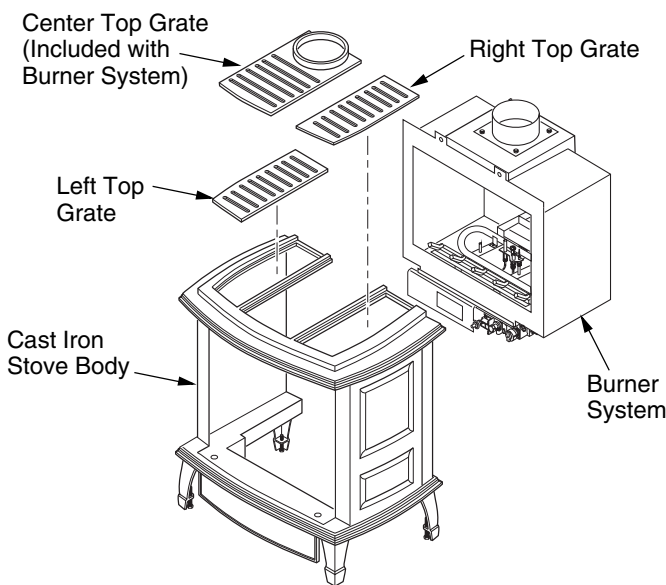

Figure 15 - Installing Burner System Into Cast Iron Stove Body

INSTALLING OPTIONAL BLOWER ACCESSORY

NOTICE: If installing blower in an existing stove burner system with gas connections, shut off gas supply and disconnect heater from gas supply. Contact a qualified service person to do this.

1. Remove 4 hex screws securing rear cover to back of stove body (see Figure 16).
2. Separate bottom cover from rear cover by loosening the 8 mounting screws (see Figure 16).
3. Align the holes in the top mounting tabs of blower with the holes in wall of rear cover. Using the 4 screws provided, mount blower and tighten screws securely (see Figure 17).
4. **Thermostat Blower Only:** Attach thermal switch and bracket to inside rear cover wall with two hex head screws provided as shown in Figure 17. After securing bracket to rear cover, carefully bend along existing bend line on bracket to almost a 90° angle (see Figure 17). This will allow thermal switch to be positioned against stove rear wall and sense temperature when in operating mode.

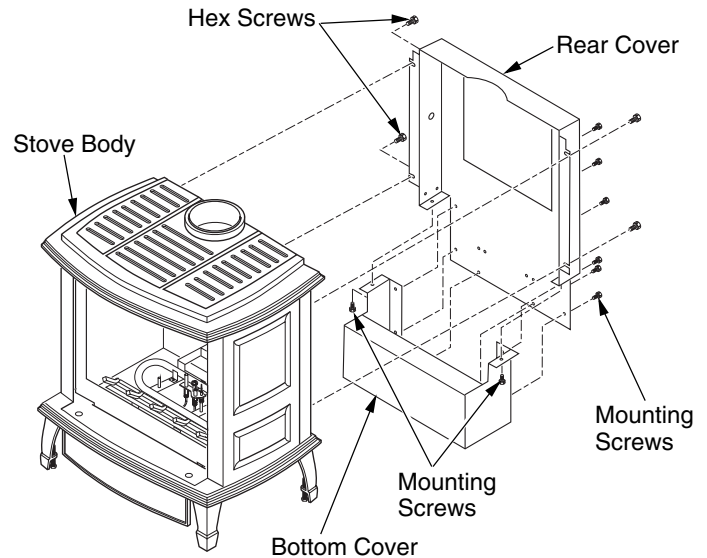

Figure 16 - Removing Rear Cover and Bottom Cover from Stove Body

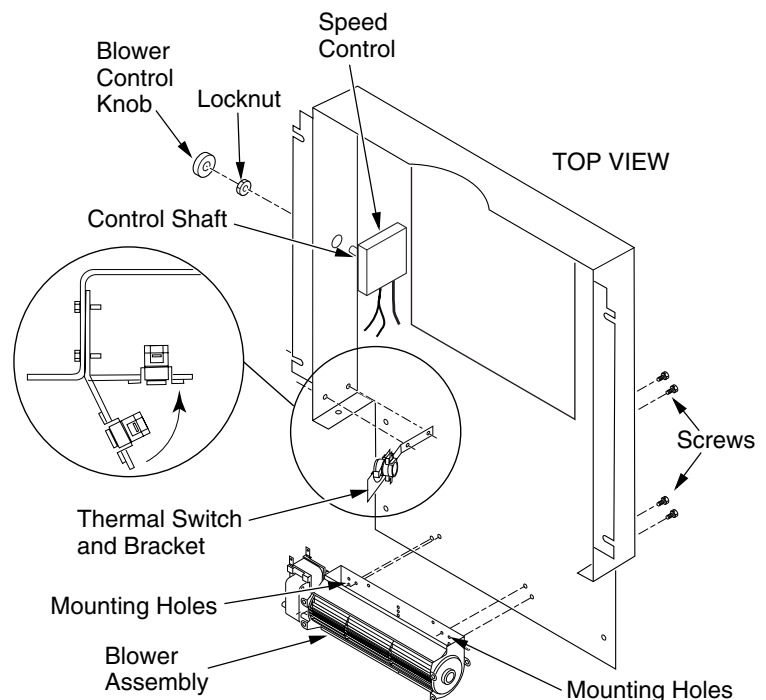

Figure 17 - Blower Assembly, Speed Control, and Thermal Switch Locations

CAST IRON STOVE AND B-VENT BURNER SYSTEM ASSEMBLY

Continued

- Place speed control on left inside of rear cover and push the plastic control shaft through opening (see Figure 17, page 7).
- While supporting speed control, secure control shaft with lock nut by pushing and turning lock nut with pliers clockwise until tight against the side of rear cover. Place control knob provided onto shaft.
- Place the green ground wire between the bottom hole on the blower assembly and the hex screw and tighten (see Figure 18).
- Connect the blue wire on the blower assembly to one side of the thermal switch (see Figure 18).
- Connect the black wire to the other side of the thermal switch (see Figure 18).
- Connect the white wire to the other terminal on the blower motor assembly (see Figure 18). Make sure the thermal switch has been properly installed to fit against back of burner system insert after the rear cover assembly has been reinstalled.
- Make sure all wire connections to terminals on blower motor and thermal switch are securely attached and that the screw retaining the green ground wire is tight.
- Check to make sure that the power cord is completely clear of the blower wheel and that there are no foreign objects in blower wheel.

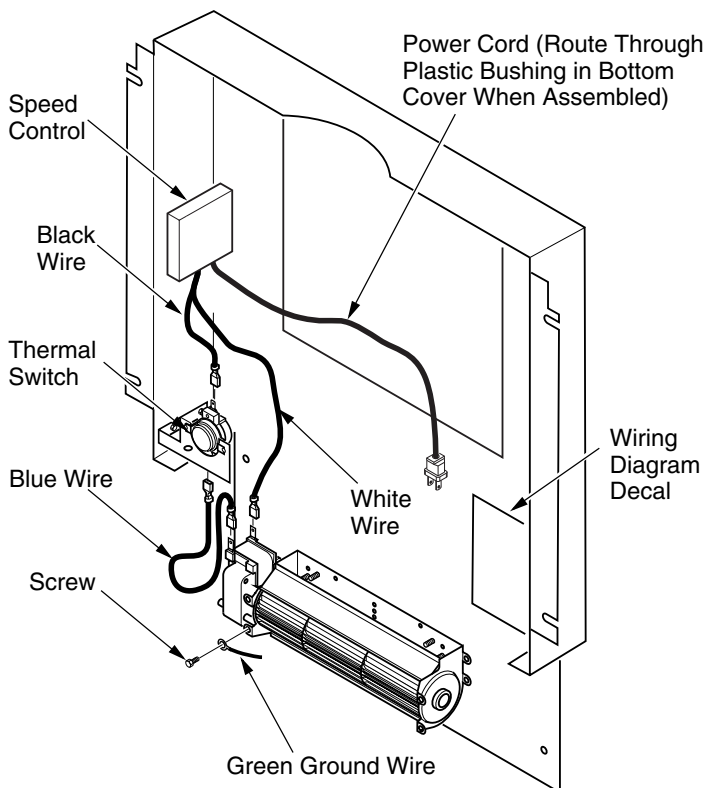

Figure 18 - Blower Wiring Layout

⚠ WARNING: Never touch the blower wheel while in operation.

- Peel off the backing paper and stick the supplied wiring diagram decal on the inside of rear cover as shown (see Figure 18).
- Reattach bottom cover to rear cover with 8 screws (see Figure 16, page 7). Make sure that you don't pinch any wires during reassembly. Route power cord through plastic bushing in bottom of rear cover.

⚠ WARNING: Failure to position the parts in accordance with supplied diagrams or failure to use only parts specifically approved with this heater may result in damage or personal injury.

INSTALLING REAR COVER

- Place rear cover behind stove body. Rear cover will rest on the bottom ledge of the stove body.
- Using hex screws provided, attach rear cover to back of stove body. See Figure 19. **IMPORTANT:** This rear cover must be securely in place before venting pipes are installed.
- Open lower door panel. The valve is attached to the underside of the burner system assembly.
- Connect or reconnect gas supply, see *Connecting Stove/Burner System to Gas Supply* on page 14.

⚠ WARNING: A qualified installer or service person must connect burner system to gas supply. Follow all local codes.

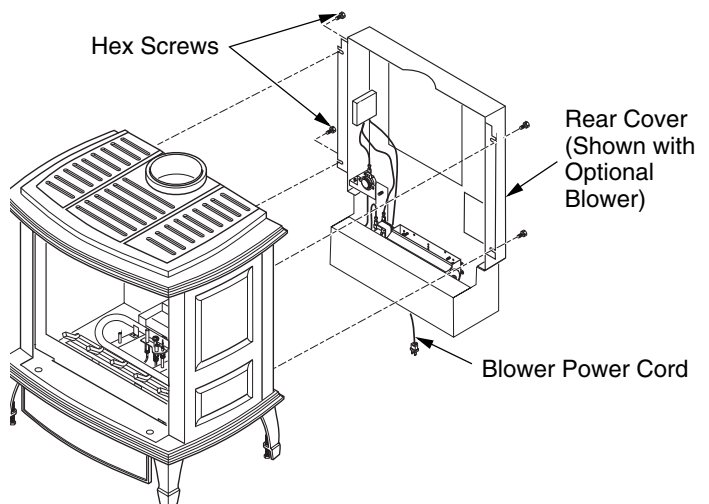

Figure 19 - Installing Rear Cover (Shown with Optional Blower Accessory)

For more information, visit www.desatech.com

VENTING INSTALLATION

⚠ WARNING: Read all instructions completely and thoroughly before attempting installation. Failure to do so could result in serious injury, property damage, or loss of life. Operation of improperly installed and maintained venting system could result in serious injury, property damage, or loss of life.

NOTICE: Failure to follow these instructions will void the warranty.

INSTALLATION PRECAUTIONS

Consult local building codes before beginning the installation. Only a qualified service person should install venting system. The installer must follow these safety rules:

- Wear gloves and safety glasses for protection
- Use extreme caution when using ladders or when on roof tops
- Be aware of electrical wiring locations in walls and ceilings

The following actions will void the warranty on your venting system:

- Installation of any damaged venting component
- Unauthorized modification of the venting system
- Installation of any component part not manufactured or approved by DESA
- Installation other than as instructed by these instructions

Your DESA stove with B-vent burner system is approved for use with any listed gas vent. A listed gas vent is a factory made and listed system designed, and installed exclusively for removing products of combustion, excess air, and dilution air resulting from burning fuel gas. Metal vents, the most common type of vent, employ double wall construction enclosing an insulating air space. This air space both helps keep flue gases warm and reduce heat transferred to nearby combustibles. This appliance is equipped with a safety control system designed to protect against improper venting of combustion products.

It is very important that the venting system maintain its balance between the combustion air intake and the flue gas exhaust. Certain limitations apply to vent configurations and must be strictly followed.

⚠ WARNING: This gas stove with burner system and vent assembly must be vented directly to the outside. The venting system must NEVER be attached to a chimney serving a separate solid fuel burning appliance.

TYPE B-VENT INSTALLATION (Listed B-0 or Greater)

Before beginning installation be sure that the overall height and gas vent size conform to building code requirements. Gas vents extending

through pitched roofs can extend a minimum height of at least 600 mm (2') higher than any obstruction within 3m (10'). Gas vents extending through flat roofs are required to extend at least 600 mm (2') above the roof and at least 600 mm (2') higher than any portion of the building or adjoining building within 3m (10') of the gas vent.

- In absence of local codes, follow Section 7.0 of the current *National Fuel Gas Code NFPA 54/ANSI Z223.1* and the *Natural Gas Installation Code* - vent sizings for Category I systems using double wall B-1 vent pipe.
- Where the gas vent extends through accessible spaces, it should be enclosed to avoid personal contact and damage. Enclosure walls should have a fire rating equal to or greater than the floors through which the gas vent passes except in single or two-family dwellings.
- Situate the gas vent in the structure so that it can be installed without cutting joists, sills, plates, or major load bearing partitions or members. It is also important to locate the base of the gas vent as near as possible to the heating appliance.
- This burner system must be properly connected to a venting system. This burner system is equipped with a vent safety shutoff system.
- Use only vents labeled "FOR EXTERIOR USE" above the roofline.
- Consult the authority having jurisdiction to select the correct gas vent diameter. Avoid using a larger than necessary diameter.

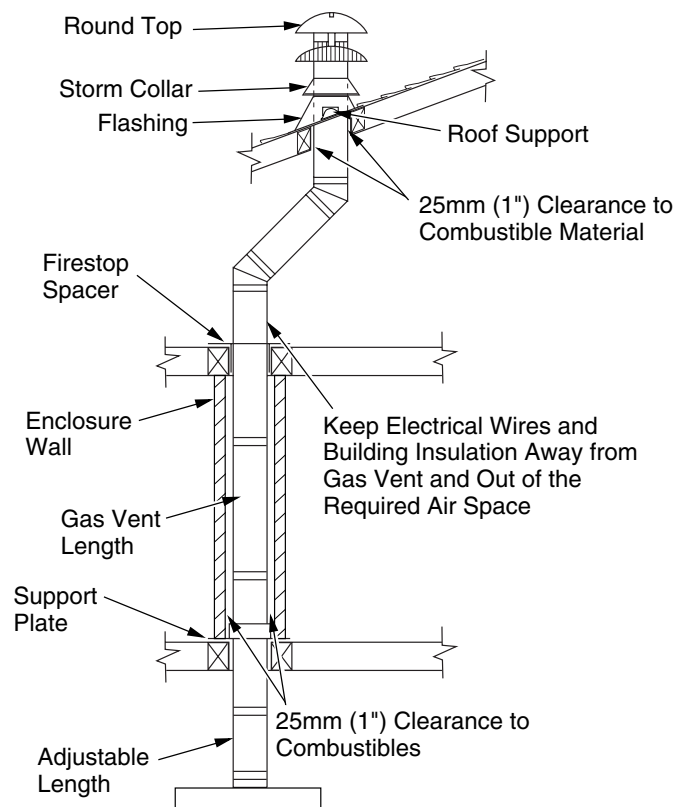

Figure 20 - Typical B-Vent Installation

VENTING INSTALLATION

Continued

INSTALLATION OF LISTED B-1 VENT

⚠ WARNING: Installation should only be made by qualified persons who are familiar with the safety procedures required for the installation of the product, who are equipped with the proper tools and testing instruments, and who have achieved proper certification of licensing. Installations made by unqualified persons can result in the risk of injury or electrical shock which can be serious or even fatal.

Figures 21 through 23 show other options for the gas vent. When venting through a side wall your vent pipe must have the proper temperature rating (see Figure 23). Manufacturer's clearances must also be maintained. Consult the authority having jurisdiction in your area regarding venting through side wall.

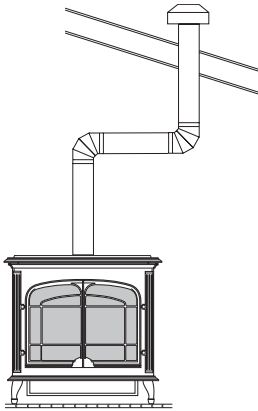

Figure 21 - Vertical Venting Through Ceiling Using Two 90° Elbows (Oxford™ Model Shown)

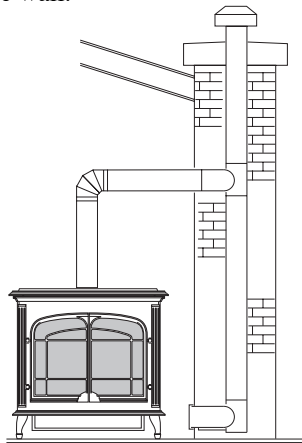

Figure 22 - Vertical Venting Configuration Through Chimney (Oxford™ Model Shown)

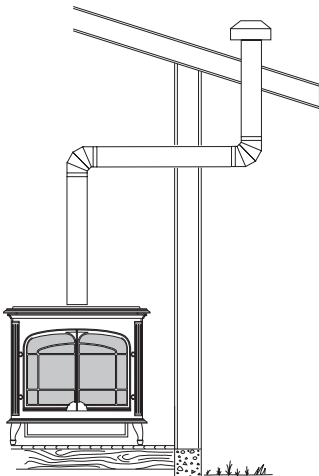

Figure 23 - Venting Through a Side Wall (Oxford™ Model Shown)

INSTALLING VENT SYSTEM IN A CHASE

A chase is a vertical box-like structure built to enclose venting that runs along the outside of a building. A chase is not required for such venting.

NOTICE: Treatment of firestops and construction of the chase may vary from building type to building type. These instructions are not substitutes for the requirements of local building codes. You must follow all local building codes.

Note: When installing in a chase, you should insulate the chase as you would the outside walls of your home. This is especially important in cold climates. Minimum clearance between vent pipes and combustible materials such as insulation is 1".

CHECKING VENT CAPACITY

Complete all gas piping, electrical, and vent connections. After adjusting the burner system and lighting the main burners, allow a couple of minutes for warm-up. Hold a lighted match just under the rim of the draft hood relief opening. Proper venting will draw the flame toward or into the draft hood. Improper venting, indicated by escape or spillage of burned gas, will cause match to flicker or go out. Smoke from a cigarette will also be pulled into the draft hood if the vent is drawing properly.

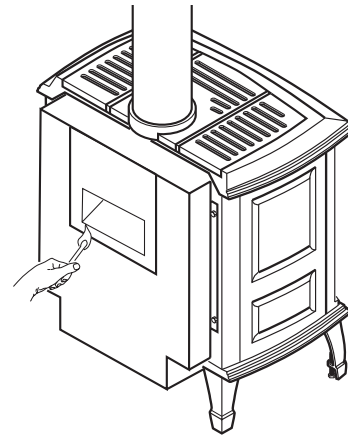

Figure 24 - Test for Proper Venting

For more information, visit www.desatech.com

VENTING INSTALLATION

Continued

CHIMNEYS

- Complete familiarity with chimney condition, height, size, clearance to combustibles and other factors is essential.

NOTICE: Consult the authority having jurisdiction in your area regarding masonry chimney venting applications.

NOTICE: A complete chimney inspection by a qualified person should be performed.

- Appliances using B-vent connectors to vent into a masonry or factory-built chimney should not exceed 1 1/2 feet in length for every inch of connector diameter (3" vent connector has a maximum 4 1/2 foot length; 5" connector has maximum 7 1/2 foot length).
- Oversized chimneys should be relined with appropriate listed relining systems.
- Cleanout access may be required.

RELINING SYSTEMS

- Suitability and approval of relining materials should be determined.
- Condition, size, height, and termination of the chimney to be relined must be determined.
- No substitution of components should be made.
- Joints and connectors should be made according to manufacturer's instructions.

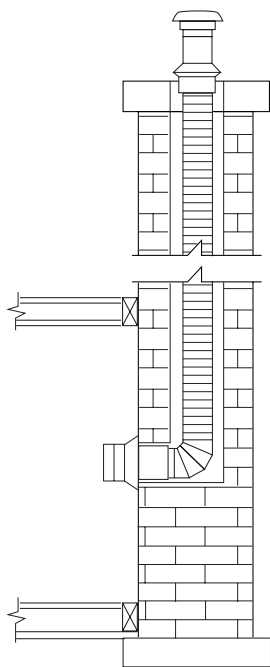

Figure 25 - Straight Installation into Masonry Chimney

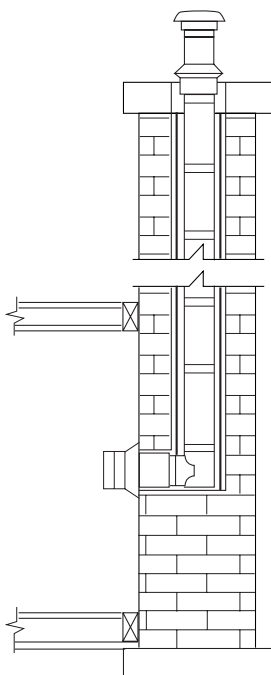

Figure 26 - Typical Straight Installation with Listed Chimney Liner

NOTICE: Consult the authority having jurisdiction in your area regarding listed chimney liner venting applications.

⚠ WARNING: Operation of improperly installed and maintained venting system could result in serious injury, property damage, or loss of life.

HIGH ALTITUDE INSTALLATION

Your DESA B-vent burner system has been CSA tested and approved for operation at altitudes in the USA from 0-2000 feet and in Canada from 0-4500 feet.

When installing this burner system at an elevation above 2000 feet (in the USA), you may need to decrease the input rating by changing the existing burner orifice to a smaller size. Reduce input 4% for each 1000 feet above sea level. Check with your local gas company for proper orifice size identification and proper orifice for your location.

When installing this stove and burner system at an elevation above 4500 feet (in Canada), check with local authorities.

For assistance with any high altitude installation contact DESA's Technical Service Department at 1-866-672-6040.

TROUBLESHOOTING VENTING PROBLEMS

Most venting problems are caused by incorrect vent sizing, improper installation, or inadequate air supply. A preliminary check for a field problem might include:

- Checking the vent sizing according to manufacturer's specifications, appliance input, and venting configuration
- Examining the entire venting system for faults such as disconnected joints for damaged vent sections
- Making sure vent and air openings are not obstructed

If these procedures do not reveal the source of the problem, troubleshooting may include attention to common venting problems.

FLUE GAS SPILLAGE

Spillage occurs when flue gases cannot exit the vent system and back up into the dwelling. A primary symptom of appliances equipped with a Vent Safety Shutoff System (flue spill switch) is unexplained appliance shutoffs. Other symptoms of flue gas spillage at the draft hood include condensation on walls and windows and/or noticeable odors. Spillage may also result in the release of carbon monoxide, a colorless, odorless, highly toxic gas. A simple spillage test can be conducted if spillage is suspected. See *Checking Gas Connection*, page 14.

CAUSES OF SPILLAGE AND CORRECTIVE ACTION

Incorrect Vent Sizing

If the vent is too small or too short, spillage may occur. If the vent is too large, excessive dilution air may cool flue gases and reduce draft, causing spillage. The vent cap size should also be checked. Check manufacturer's instructions, appliance input rating, and appropriate sizing tables.

Venting Condition

Loose joints can affect draft and cause spillage. "Mashed" vent sections and damaged vent caps can restrict flow and cause spillage. Examine and replace as needed.

Obstructions

Small animals or birds may get into and block the vent or draft hood outlet. Dust, lint, and foreign objects may obstruct air inlets. Remove obstructions and clean openings.

Lateral Run

Lengthy horizontal or non-vertical runs cause resistance to flow and may reduce draft enough to cause spillage. The pitch of lateral runs can also be a problem; lateral runs should be pitched 1/4" rise per foot of horizontal run from the appliance to the vent.

Elbows

Too many elbows cause excessive restriction of flow and may result in spillage. Usually, two 90° turns can be tolerated in a properly sized venting system. More than two may cause problems and necessitate changing the system.

Negative Pressure in the Dwelling

An extremely tight house may not supply adequate combustion and venting air. Use of mechanical exhaust such as a dryer vent or range vent may worsen the problem. An air exchange system must be installed in the dwelling to correct this problem.

Flue Gas Cooling

Venting exposed to extremely cold temperatures or venting of single wall construction loses heat needed to maintain draft; massive masonry chimneys absorb needed heat. If the flue gases cool excessively, draft is reduced and spillage may result. Use proper materials, insulate and protect properly, reline when necessary.

Down Drafts

In certain wind conditions and in certain relationships with nearby structures and objects, high pressure conditions may affect draft negatively. Relocate the vent cap, raise its height, or use an approved high wind cap.

CAST IRON STOVE AND B-VENT BURNER SYSTEM INSTALLATION

NOTICE: This burner system is intended for use as supplemental heat. Use this burner system along with your primary heating system. Do not install this stove and burner system as your primary heat source. If you have a central heating system, you may run system's circulating blower while using heater. This will help circulate the heat throughout the house. In the event of a power outage, you can use this burner system as your primary heat source.

CHECK GAS TYPE

Use proper gas type for the burner system unit you are installing. If you have conflicting gas types, do not install burner system. See dealer where you purchased the stove and burner system for proper burner system according to your gas type. Conversion kits are also available for these models, see *Accessories* on page 32.

IMPORTANT: If installing gas conversion kit, do so at this time. Be sure to follow all installation instructions included with conversion kit.

CAST IRON STOVE AND B-VENT BURNER SYSTEM INSTALLATION

Continued

INSTALLING GAS PIPING TO STOVE LOCATION

WARNING: A qualified installer or service person must connect burner system to gas supply. Follow all local codes.

CAUTION: For propane/LP units, never connect burner system directly to the propane/LP supply. This burner system requires an external regulator (not supplied). Install the external regulator between the burner system and propane/LP supply.

Installation Items Needed

Before installing stove and burner system, make sure you have the items listed below.

- external regulator (supplied by installer)
- piping (check local codes)
- sealant (resistant to propane/LP gas)
- equipment shutoff valve *
- test gauge connection *
- sediment trap
- tee joint
- pipe wrench
- approved flexible gas line with gas connector (if allowed by local codes) (not provided)

* A CSA design-certified equipment shutoff valve with 1/8" NPT tap is an acceptable alternative to test gauge connection. Purchase the CSA design-certified equipment shutoff valve from your dealer.

For propane/LP connections only, the installer must supply an external regulator. The external regulator will reduce incoming gas pressure. You must reduce incoming gas pressure to between 11 and 14 inches of water. If you do not reduce incoming gas pressure, heater regulator damage could occur. Install external regulator with the vent pointing down as shown in Figure 27. Pointing the vent down protects it from freezing rain or sleet.

CAUTION: Use only new, black iron or steel pipe. Internally-tinned copper tubing may be used in certain areas. Check your local codes. Use pipe of 1/2" diameter or greater to allow proper gas volume to burner system. If pipe is too small, undue loss of volume will occur.

Installation must include an equipment shutoff valve, union, and plugged 1/8" NPT tap. Locate NPT tap within reach for test gauge hook up. NPT tap must be upstream from burner system (see Figure 28).

Check your building codes for any special requirements for locating equipment shutoff valve to stoves.

Apply pipe joint sealant lightly to male NPT threads. This will prevent excess sealant from going into pipe. Excess sealant in pipe could result in clogged burner system valves.

WARNING: Use pipe joint sealant that is resistant to liquid petroleum (LP) gas.

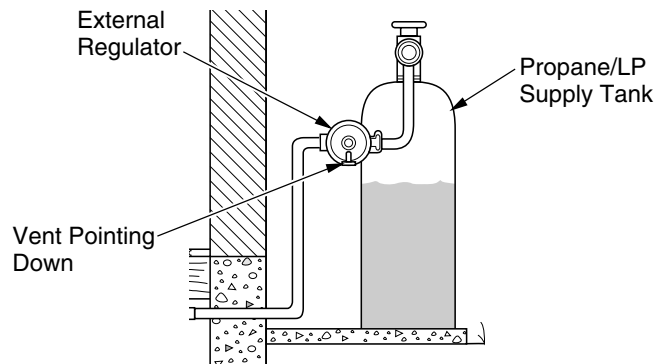
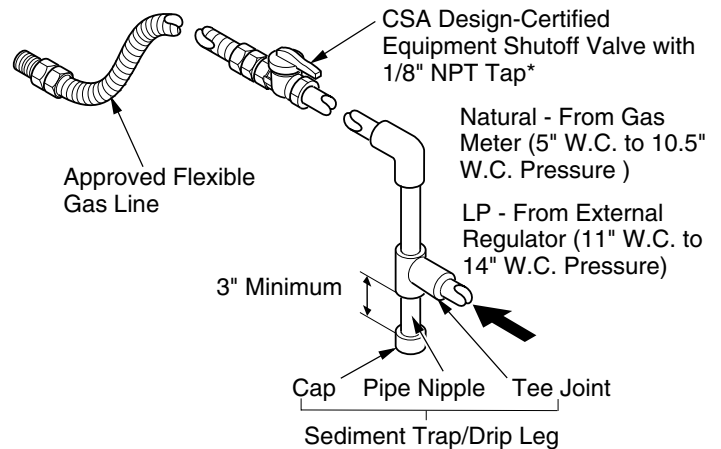

Figure 27 - External Regulator with Vent Pointing Down (Propane/LP Only)



* The CSA design-certified equipment shutoff valve may be supplied with the appliance or you can purchase it from your dealer.

Figure 28 - Gas Connection

CAST IRON STOVE AND B-VENT BURNER SYSTEM INSTALLATION

Continued

We recommend that you install a sediment trap/drip leg in supply line as shown in Figure 28, page 13. Locate sediment trap/drip leg where it is within reach for cleaning. Install in piping system between fuel supply and burner system. Locate sediment trap/drip leg where trapped matter is not likely to freeze. A sediment trap traps moisture and contaminants. This keeps them from going into burner system gas controls. If sediment trap/drip leg is not installed or is installed wrong, burner system may not run properly.

CONNECTING STOVE/BURNER SYSTEM TO GAS SUPPLY

Installation Items Needed

- 5/16" hex socket wrench or nut-driver
 - sealant (resistant to propane/LP gas, not provided)
1. Open lower door panel.
 2. Route flexible gas line (provided by installer) from equipment shutoff valve to burner system (see Figure 29). Route flexible gas supply line and attach to valve.
 3. Check all gas connections for leaks. See *Checking Gas Connections*, column 2.

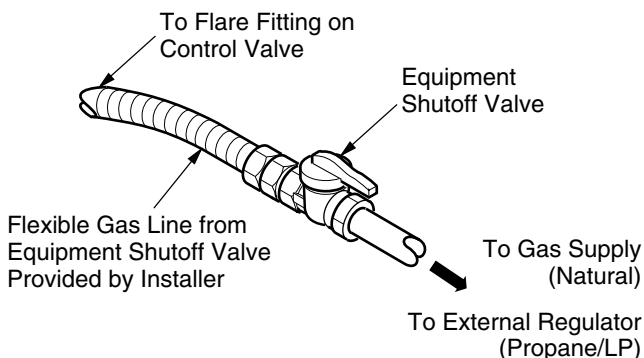

Figure 29 - Flexible Gas Line

CHECKING GAS CONNECTIONS

⚠ WARNING: Test all gas piping and connections, internal and external to unit, for leaks after installing or servicing. Correct all leaks at once.

⚠ WARNING: Never use an open flame to check for a leak. Apply noncorrosive leak test solution to all gas joints. Bubbles forming show a leak. Correct all leaks at once.

Pressure Testing Gas Supply Piping System

Test Pressures In Excess Of 1/2 PSIG (3.5 kPa)

1. Disconnect appliance with its appliance main gas valve (control valve) and equipment shutoff valve from gas supply piping systems. Pressures in excess of 1/2 psig (3.5 kPa) will damage burner system gas regulator.
2. Cap off open end of gas pipe where equipment shutoff valve was connected.
3. Pressurize supply piping system by either opening propane/LP supply tank valve for propane/LP gas burner system or opening main gas valve located on or near gas meter for natural gas burner system, or using compressed air.
4. Check all joints of gas supply piping system. Apply noncorrosive leak test solution to all gas joints. Bubbles forming show a leak. Correct all leaks at once.
5. Reconnect burner system and equipment shutoff valve to gas supply. Check reconnected fittings for leaks.

Test Pressures Equal To or Less Than 1/2 PSIG (3.5 kPa)

1. Close equipment shutoff valve (see Figure 30).
2. Pressurize supply piping system by either opening propane/LP supply tank valve for propane/LP gas burner system or opening main gas valve located on or near gas meter for natural gas burner system, or using compressed air.
3. Check all joints from propane/LP supply tank or gas meter to equipment shutoff valve (see Figure 31 for propane/LP or Figure 32 for natural, page 15). Apply noncorrosive leak test solution to all gas joints. Bubbles forming show a leak. Correct all leaks at once.

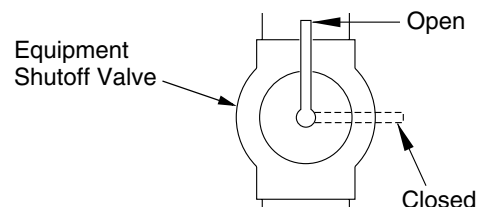

Figure 30 - Equipment Shutoff Valve

CAST IRON STOVE AND B-VENT BURNER SYSTEM INSTALLATION

Continued

Pressure Testing Burner System Gas Connections

1. Open equipment shutoff valve (see Figure 30, page 14).
2. Open propane/LP supply tank valve for propane/LP burner system or main gas valve located on or near gas meter for natural gas burner system.
3. Make sure control knob of burner system is in the OFF position.
4. Check all joints from equipment shutoff valve to thermostat gas valve (see Figure 31 for propane/LP or Figure 32 for natural, page 15). Apply commercial leak test solution to all gas joints. Bubbles forming show a leak. Correct all leaks at once.
5. Light burner system (see *Lighting Instructions*, page 19). Check all other internal joints for leaks.
6. Turn off burner system (see *To Turn Off Gas to Appliance*, page 19).

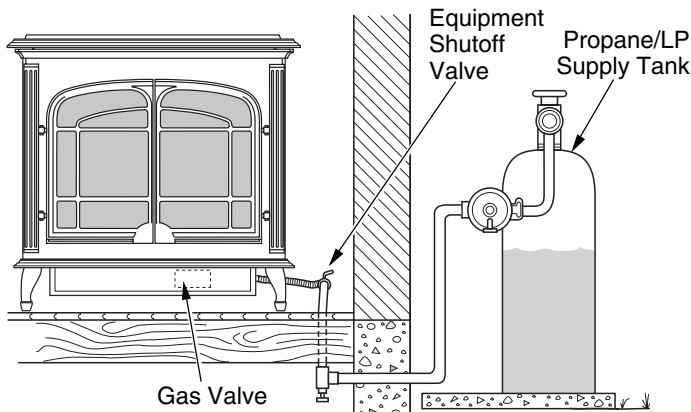

Figure 30 - Checking Gas Joints for Propane/LP Gas Burner System (Oxford™ Model Shown)

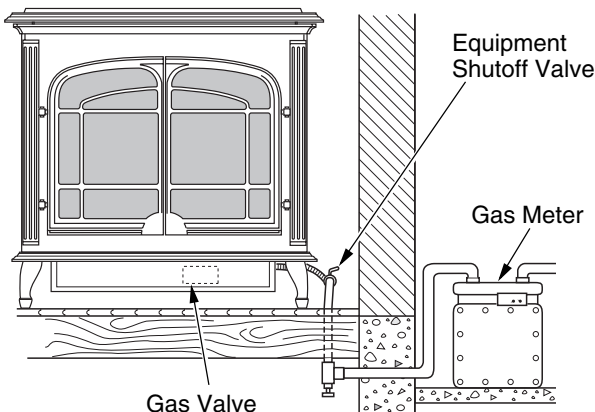

Figure 32 - Checking Gas Joints for Natural Gas Burner System (Oxford™ Model Shown)

INSTALLING OPTIONAL WALL MOUNT SWITCH - GWMS2

1. Connect one terminal of 25 ft. wire for the wall switch to the TPTH terminal on the valve. Connect remaining wire terminal to the TH terminal on the valve. Make sure that the wire terminals are in the positions on the unit as pictured in Figure 33. If wires are not connected as shown, the switch will not work.
2. Route the 25 ft. wire through openings provided on the sides of the burner system to a convenient location to mount your switch.
3. Connect one bare wire end to each of the terminals of the GWMS2 wall switch.
4. Install the wall switch and cover in the wall.

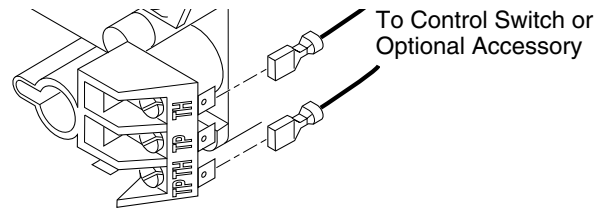

Figure 33 - Control Valve Terminals

INSTALLING OPTIONAL WALL MOUNTED THERMOSTAT - GWMT1

⚠ WARNING: Installation must be done by a qualified installer familiar with low voltage wiring procedures.

⚠ WARNING: Do not connect this thermostat to any electrical source! Electrical shock and/or fire hazard will occur.

1. Open lower door panel. The valve is attached to the underside of the burner system assembly.
2. Disconnect from the valve the wires running from the ON/OFF switch.
3. Connect one terminal of the wire for the wall thermostat to the THTP terminal on the valve. Connect remaining wire terminal to the TH terminal on the valve. Make sure that the wire terminals are in the positions on the unit as pictured in Figure 33. If wires are not connected as shown the thermostat will not work.

CAST IRON STOVE AND B-VENT BURNER SYSTEM INSTALLATION

Continued

- Route the wire to a convenient location to mount your thermostat (no outside wall). **IMPORTANT:** The wire must not exceed 25 feet in length.

The thermostat should be mounted 54" above the floor in a location where there is good air circulation. Avoid heat sources such as lamps, direct sunlight, fireplace, or heat and air conditioning ducts.

- Gently remove the cover of the thermostat from the base. Grasp the sides of the cover firmly and pull to separate from the base.
- Feed the electrical wires through the rectangular slots (from the back) on each side of the base (see Figure 34).
- Connect one bare wire end to each terminal ("W" and "R") of the thermostat base (see Figure 35).
- Install the base to the wall with screws provided with thermostat.
- Move the temperature adjustment back and forth to insure the bi-metal is free from restrictions.

⚠ WARNING: Do not connect this thermostat to a power source. Electrical shock and/or fire hazard will occur.

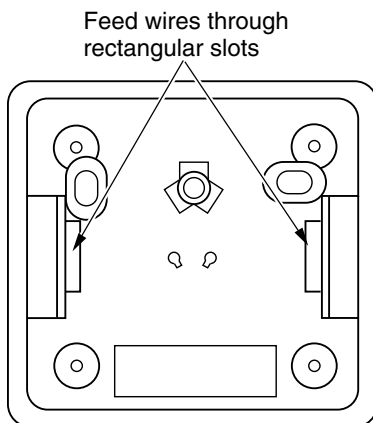

Figure 34 - Back View of Thermostat Base

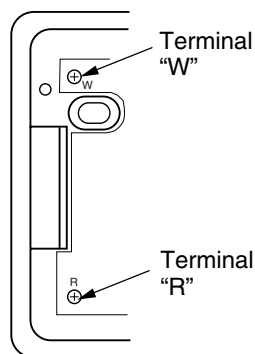

Figure 35 - Thermostat Base Terminal "W" and "R"

INSTALLING OPTIONAL WIRELESS HAND-HELD REMOTE CONTROL ACCESSORIES - GHRCB AND GHRCTB SERIES

Installing Remote Receiver

- Open bottom door on stove body.
- Disconnect wires from THTP and TH on control valve that lead to the switch (see Figure 33, page 15). Discard switch plate, screws, and nuts.
- Install battery into receiver battery clip and connect to terminals (see Figure 36).
- Place receiver into valve bracket and align holes (see Figure 37).
- Use push-in fasteners included with receiver to secure to bracket.
- Connect the wires from the receiver to the valve at TH and THTP (see Figure 33, page 15).

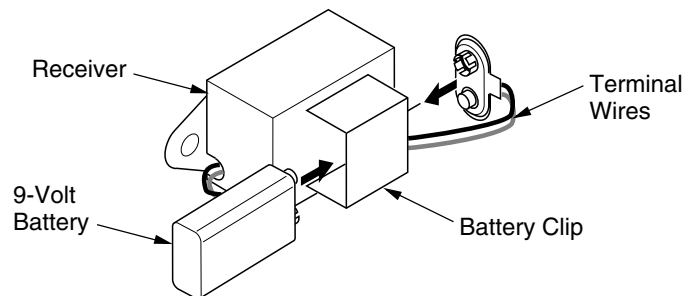

Figure 36 - Installing Battery in Receiver

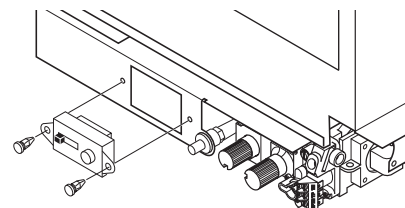

Figure 37 - Installing Remote Receiver

CAST IRON STOVE AND B-VENT BURNER SYSTEM INSTALLATION

Continued

Installing 9-Volt Battery in Hand-Held Remote Control Unit

1. Remove battery cover on back of remote control unit
2. Attach terminal wires to a 9-volt battery (not included). Place battery into the battery housing.
3. Replace battery cover onto remote control unit.

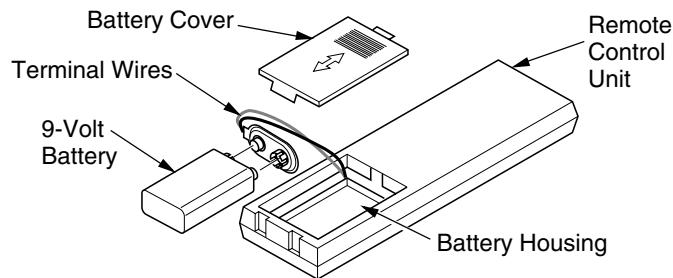

Figure 38 - Installing Battery in Hand-Held Remote Control Unit (GHRCB Only)

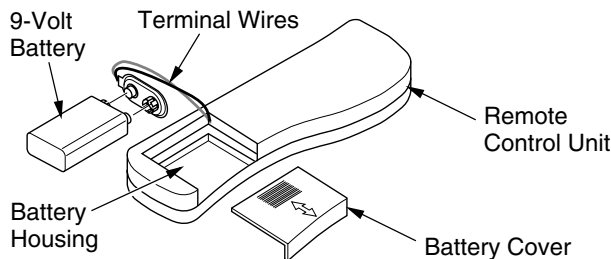

Figure 39 - Installing Battery in Hand-Held Remote Control Unit (GHRCTB Only)

REMOVING/REPLACING GLASS DOOR

You must remove glass door to install logs, lava rock, and ember material. To remove glass door, you must first remove the front panel on stove body.

CAUTION: Do not operate this burner system with a broken glass door panel or without the glass door panel securely in place. For replacement part information see *Replacement Parts*, page 26.

1. If stove front panel is still installed, remove 2 bolts from bottom of stove and one from the top of stove to remove front panel (see Figure 40). For the Oxford stove the middle grate will need to be removed to remove the top bolt.
2. Remove the screws from the 2 tabs at the top of the glass door while holding door securely keeping it from falling forward (see Figure 41).

3. Grasp door by both sides and ease it upward off of the lower bracket (see Figure 41).
4. To replace glass door, follow the above instructions in reverse.

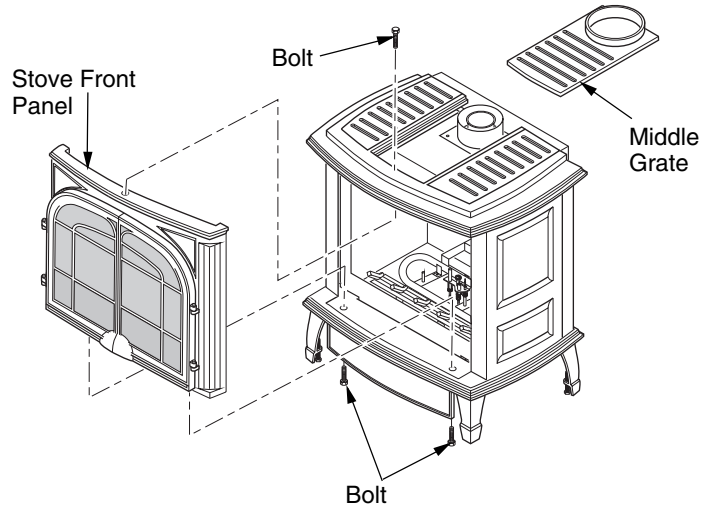

Figure 40 - Removing Front Panel from Stove (Oxford™ Model Shown)

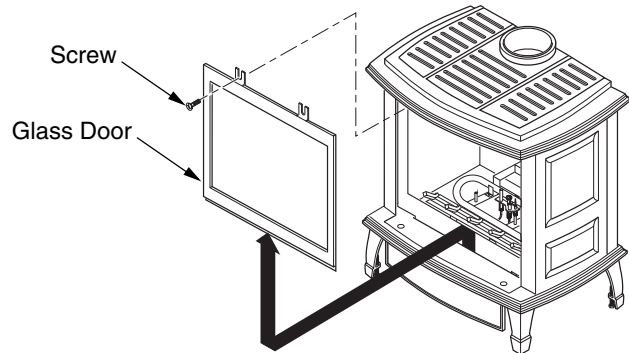

Figure 41 - Removing Glass Door from Burner System

CAST IRON STOVE AND B-VENT BURNER SYSTEM INSTALLATION

Continued

INSTALLING LOGS, LAVA ROCK, AND GLOWING EMBERS

⚠ WARNING: Failure to position the parts in accordance with these diagrams or failure to use only parts specifically approved with this burner system may result in property damage or personal injury.

It is very important to install these logs exactly as instructed in Figures 42 through 46. Do not modify logs. Only use logs supplied with freestanding burner system. Do not use if any log(s) are broken (see *Replacement Parts*, page 26).

1. Remove glass door. See *Removing/Replacing Glass Door*, page 17.
2. Place log #1 (back log) on top of grate. Make sure the notches in the bottom of the log fit over the grate (see Figure 42).
3. Rest log #2 (large front log) on the pins on the front part of the grate (see Figure 43).
4. Place log #3 (crossover log) onto the rear and front logs. Make sure it is seated properly into the notch on the front log and over the raised triangular portion of the rear log as shown in Figure 44.
5. Place log #4 (small log) onto the front left part of the grate making sure the notches fits over the prong of the grate. See Figure 45.
6. Lava rock may be placed along sides and front inside burner system bottom. This may not be visible when you have replaced the front of the stove. It is not necessary to use all of the lava rock provided.

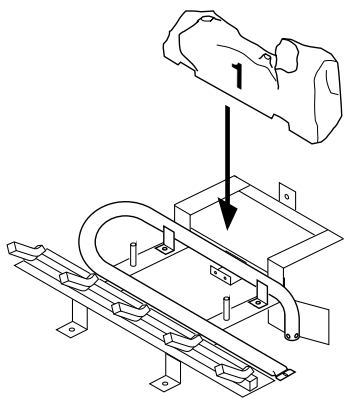

Figure 42 - Installing Log No. 1

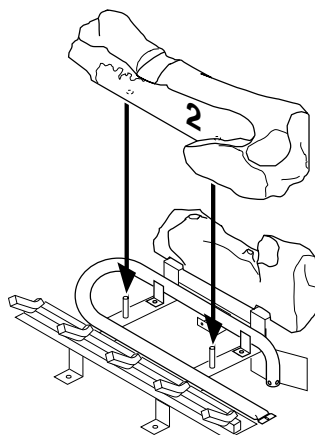

Figure 43 - Installing Log No. 2

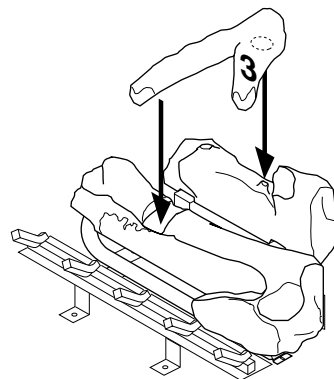

Figure 44 - Installing Log No. 3

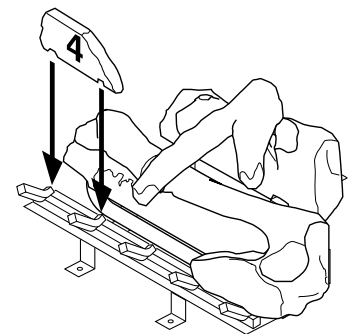

Figure 45 - Installing Log No. 4

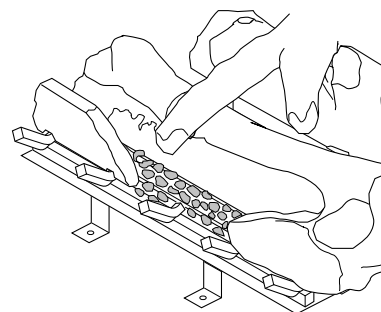

Figure 46 - Placing Ember Material on Burner

NOTICE: Do not put lava rock on burner or under burner. Placing lava rock on burner could cause performance problems.

7. Pull ember material apart into pieces no larger than a dime. Place these pieces loosely and sparingly directly onto the exposed section of the front burner and along the space between the burner and grate prongs (see Figure 46). This will create the glowing ember appearance as the flame touches the ember material. Do not block air slots by using too much ember material in one area. It is not necessary to use all of the ember material provided.
8. Replace the glass door and stove front. See *Removing/Replacing Glass Door*, page 17.

⚠ WARNING: The glass door must be securely in place before running this burner system. Do not run this burner system if glass is missing or broken.

OPERATING STOVE WITH B-VENT BURNER SYSTEM

**FOR YOUR SAFETY
READ BEFORE LIGHTING**

⚠ WARNING: If you do not follow these instructions exactly, a fire or explosion may result causing property damage, personal injury or loss of life.

- A. This appliance has a pilot which must be lighted by hand. When lighting the pilot, follow these instructions exactly.
- B. **BEFORE LIGHTING** smell all around the appliance area for gas. Be sure to smell next to the floor because some gas is heavier than air and will settle on the floor.
WHAT TO DO IF YOU SMELL GAS
 - Do not try to light any appliance.
 - Do not touch any electric switch; do not use any phone in your building.
 - Immediately call your gas supplier from a neighbor's phone. Follow the gas supplier's instructions.
- C. Use only your hand to push in or turn the gas control knob. Never use tools. If the knob will not push in or turn by hand, don't try to repair it, call a qualified service technician. Force or attempted repair may result in a fire or explosion.
- D. Do not use this appliance if any part has been under water. Immediately call a qualified service technician to inspect the appliance and to replace any part of the control system and any gas control which has been under water.

LIGHTING INSTRUCTIONS

1. **STOP!** Read the safety information above.
2. Set ON/OFF switch located on rear cover to "OFF".
3. Open lower panel.
4. Turn off all electric power to the burner system.
5. Push in gas control knob slightly and turn clockwise to "OFF".
6. Wait five (5) minutes to clear out any gas. Then smell for gas, including near the floor. If you smell gas, **STOP!** Follow "B" in the safety information above. If you don't smell gas, go to the next step.
7. The pilot is located by the main burner and should not require accessing for lighting.
8. Turn knob on gas control counterclockwise to "PILOT".
9. Push in control knob all the way and hold. Immediately light the pilot by repeatedly depressing the piezo spark ignitor until a flame appears. Continue to hold for about one (1) minute after the pilot is lit. Release knob and it will pop back. Pilot should remain lit. If it goes out, repeat steps 5 through 8.

- If knob does not pop up when released, stop and immediately call your service technician or gas supplier.
- If the pilot will not stay lit after several tries, turn the gas control knob to "OFF" and call your service technician or gas supplier.

10. Turn gas control counterclockwise to "ON".
11. Turn on all electric power to the burner system.
12. Turn the ON/OFF switch to ON position.
13. Close lower panel.

TO TURN OFF GAS TO APPLIANCE

1. Set ON/OFF switch located on rear cover to "OFF".
- 2a. Open lower panel.
- 2b. If Using Optional Hand-Held Remote: Set selector switch in the OFF position to prevent draining battery.
3. Turn off all electrical power to the appliance if service is to be performed.
4. Push in gas control knob slightly and turn clockwise to "OFF".
5. Close lower panel.

Shutting Off Burners Only (pilot stays lit)

You may shut off the burners and keep the pilot lit by doing one of the following:

1. Turn control knob clockwise to the PILOT position.
2. Set selector switch in the OFF position.

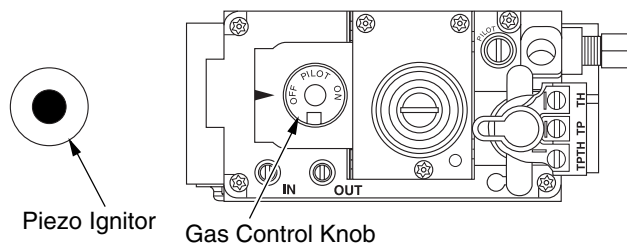

Figure 47 - Control Valve

MANUAL LIGHTING procedure

1. Remove glass door (see *Removing/Replacing Glass Door*, page 17).
2. Follow steps 1 through 8 under *Lighting Instructions*.
3. Depress control knob and light pilot with match.
4. Keep control knob pressed in for 30 seconds after lighting pilot. After 30 seconds, release control knob. Now follow steps 10 through 13.
5. Replace glass door (see *Removing/Replacing Glass Door*, page 17).

OPERATING STOVE WITH B-VENT BURNER SYSTEM

Continued

OPTIONAL REMOTE OPERATION

Note: All remote control accessories must be purchased separately (see *Accessories*, page 32). Follow instructions included with the remote control.

NOTICE: You must light the pilot before using the hand-held remote control unit. See *Lighting Instructions*, page 19.

1. After lighting, let pilot flame burn for about one minute. Turn control knob to ON position. Adjust flame adjustment knob anywhere between HI and LO. Slide the selector switch to the REMOTE position (see Figure 48). **Note:** The burner may light if hand-held remote was on when selector switch was last turned off. You can now turn the burner on and off with the hand-held remote control unit.

IMPORTANT: Do not leave the selector switch in the REMOTE or ON position when the pilot is not lit. This will drain the battery.

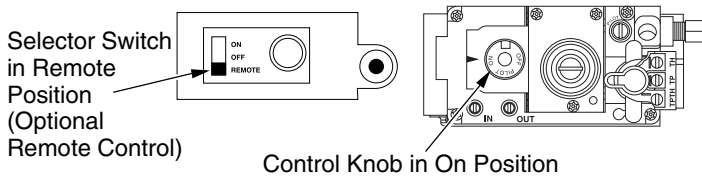

Figure 48 - Setting the Selector Switch, Control Knob, and Flame Adjustment Knob for Remote Operation

ON/OFF SERIES (MODELS GHRCB AND CGHRCB)

Hold the control button on the hand-held remote until burner turns on. Hold the control button again until burner turns off (see Figure 49).

To Lock press both buttons on hand-held remote control until light stops flashing. Hand-held remote control is now locked. If the fire is on it will be turned off automatically. In the locked state, the light will not light up when any button is pressed.

To Unlock press both buttons together on hand-held remote control until the light stops flashing. The hand-held remote is now unlocked.

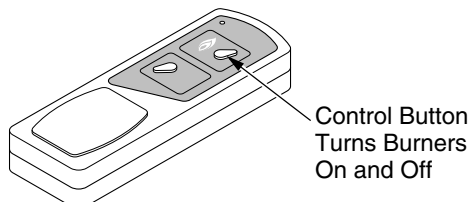

Figure 49 - On/Off Hand-Held Remote Control Unit (C)GHRCB

THERMOSTAT SERIES (MODELS GHRCTB AND CGHRCB)

The hand-held remote can be operated using either the manual mode (MANU) or thermostatic mode (AUTO) (see Figure 50). To select Fahrenheit/Centigrade mode display, carefully press the °C/°F mode button with the end of a paper clip or similar blunt object.

Manual Mode

1. Press the POWER and LOCK buttons together to turn on the hand-held remote control.
2. Press the MANU button to turn on the fireplace.
3. Press the POWER and LOCK buttons together to turn off the fireplace.

Auto (Thermostatic) Mode

1. Press the POWER and LOCK buttons together to turn on the hand-held remote control.
2. Press AUTO button to select this mode.
3. Set the desired room temperature by pressing the TEMP + or - buttons.
4. Press the POWER and LOCK buttons together to turn off the fireplace

Note: Do not leave the hand-held remote in the AUTO mode close to the fireplace. The radiant heat from the fireplace will turn off the fireplace. Ideally, place the hand-held remote in the center of the room facing towards the fireplace.

Note: Do not hold the hand-held remote for a long time. Body temperature will affect its operation in the AUTO mode.

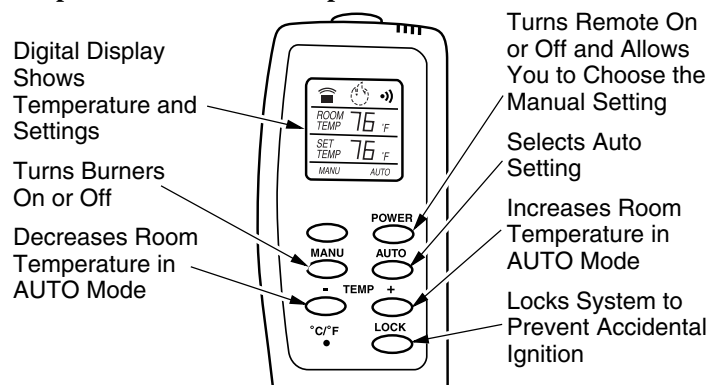

Figure 50 - Thermostat Hand-Held Remote Control Unit Selections (C)GHRCTB

Safety Features

When away from home for an extended period of time or as a child safety feature to prevent accidental ignition of the fireplace, the receiver ON/OFF/REMOTE switch should be in the OFF position.

For more information, visit www.desatech.com

OPERATING STOVE WITH B-VENT BURNER SYSTEM

Continued

Auto Shutoff Feature

1. If the average room temperature exceeds 82 degrees Fahrenheit (28 degrees Centigrade), the hand-held remote control will perform a safety override and shut the fireplace off. This feature is not available in the MANU mode.
2. The receiver continuously receives signals from the hand-held remote to control the room temperature. If the hand-held remote is misplaced, obstructed, or for any reason cannot transmit to the receiver, the receiver will shut off the fireplace after 8 minutes.

Key Pad Lock Feature

This feature allows the user to lock/unlock the keypad on the hand-held remote in the MANU or AUTO mode to prevent inadvertent operation (i.e. children operating the hand-held remote control, etc.). The keypad is locked in either on or off. Press the POWER and LOCK buttons together to turn the unit on or off.

OPERATING OPTIONAL GWMT1 WALL MOUNTED THERMOSTAT

WARNING: Do not connect the thermostat to a power source. Electrical shock and/or a fire hazard will occur.

Light the burner system as instructed in *Lighting Instructions* on page 19. Set wall thermostat to desired temperature.

This thermostat has been electronically calibrated at the factory and requires no adjustment or leveling.

Upon installation, the thermostat must be allowed to stabilize at room temperature for a minimum of 30 minutes for proper operation.

To turn the burner system off, adjust thermostat to the lowest setting and turn the gas control knob back to PILOT. The pilot will remain lit.

IMPORTANT: To turn the pilot off, turn the control knob on the heater to the OFF position.

OPERATING OPTIONAL BLOWER ACCESSORY

Blower controls are located on the left side of the rear cover when standing in front of stove with burner system installed.

The DA3610TA thermostatically-controlled blower has an ON setting and an OFF setting. The blower will only run when the switch is in the ON position. In the OFF position, the blower will not operate.

If you are using DA3610TA blower with optional thermostat (wall mount or remote control) for the burner system, your burner system and blower will not turn on and off at the same time. The burner system may run for several minutes before the blower turns on. After the burner system modulates to the pilot

position, the blower will continue to run. The blower will shut off after the burner system firebox temperature decreases.

The blower helps distribute heated air from the stove. Periodically check the top grates of the stove and remove any dust, dirt, or other obstructions that will hinder the flow of air.

INSPECTING BURNERS

Check pilot flame pattern and burner flame patterns often.

PILOT ASSEMBLY

The pilot assembly is factory preset for the proper flame height. Alterations may have occurred during shipping and handling. Call a qualified service person to readjust the pilot if necessary.

The height of the thermopile must be 3/8" to 1/2" above the pilot flame as shown in Figure 51. The flame from the pilot burner must extend beyond the thermopile.

If your pilot assembly does not meet these requirements:

- turn burner system off (see *To Turn Off Gas to Appliance*, page 19)
- see *Troubleshooting*, page 23

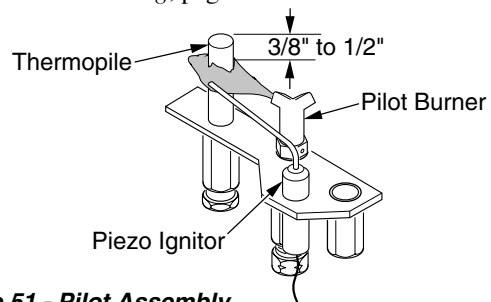

Figure 51 - Pilot Assembly

BURNER FLAME PATTERN

Burner flames will be steady; not lifting or floating. Flame patterns will be different from unit to unit and will vary depending on installation type and weather conditions.

If the vent configuration is installed incorrectly, the flames will lift or "ghost". This can be dangerous. Inspect the flames after installation to ensure proper installation and performance.

Figure 52 shows a typical flame pattern. If burner flame pattern differs from that described:

- turn burner system off (see *To Turn Off Gas to Appliance*, page 19)
- see *Troubleshooting*, page 23

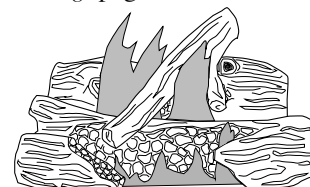

Figure 52 - Typical Flame Pattern

CLEANING AND MAINTENANCE

⚠ WARNING: Turn off burner system and let cool before cleaning.

⚠ CAUTION: You must keep control areas, burners, and circulating air passageways of stove with burner system clean. Inspect these areas of stove and burner system before each use. Have burner system inspected yearly by a qualified service person. Burner system may need more frequent cleaning due to excessive lint from carpeting, bedding material, pet hair, etc.

GLASS DOOR

⚠ WARNING: Handle glass door panel with care. Do not strike, slam or otherwise abuse glass. Do not operate burner system with the glass door removed, cracked, or broken.

⚠ WARNING: Do not use abrasive cleaners as this may damage glass. Use a non-abrasive household glass cleaner to clean glass. Do not clean glass when hot.

Glass must be cleaned periodically. During start-up it is normal for condensation to form on the inside of the glass causing lint, dust, and other airborne particles to cling to the glass surface. During initial start-up a slight film may form on the glass due to paint curing. The glass should be cleaned several times with a non-ammonia, non-abrasive household cleaner and warm water after the first two weeks of operation. Thereafter, clean the glass two or three times during each heating season, depending on the usage and circumstances present. Refer to *Removing/Replacing Glass Door* on page 17 of this manual when removing glass door for cleaning.

⚠ WARNING: Only parts supplied by the manufacturer should be used when replacing broken or damaged glass door panel (see *Replacement Parts*, page 26). This glass door panel is a complete unit. No substitute materials may be used.

⚠ CAUTION: Wear gloves and safety glasses while handling or removing broken glass. Do not remove if glass is hot. Keep children and pets away from glass.

If glass has been broken, carefully remove glass door (see *Removing/Replacing Glass Door*, page 17). Vacuum all glass pieces with a shop vac.

⚠ CAUTION: Do not vacuum if pieces are hot.

Use only the ceramic glass door replacement intended for this burner system (see *Replacement Parts*, page 26 for details on ordering). No substitutions may be made. See *Removing/Replacing Glass Door*, page 17 for instructions for replacing glass door.

⚠ WARNING: Do not operate burner system with the glass door removed, cracked, or broken.

PILOT AND BURNERS

- Remove ember material before cleaning burners and replace when cleaning is complete.
- Burner and controls should be cleaned with compressed air to remove dust, dirt, or lint.
- Use a vacuum cleaner or small, soft bristled brush to remove excess dust, dirt, or lint.

LOGS

- If you remove logs for cleaning, refer to *Installing Logs, Lava Rock, and Glowing Embers*, page 18, to properly replace logs.
- Use a vacuum cleaner to remove any carbon build-up on logs.
- Replace log(s) if broken. See *Replacement Parts* on page 26.
- Replace ember material periodically as needed. See *Replacement Parts* on page 26.

VENTING SYSTEM

Conduct annual inspection of the venting system following these guidelines:

1. Check areas of venting system that are exposed to the weather for corrosion (rust spots or streaks and, in extreme cases, holes). Have these items replaced immediately by a qualified service person.
2. Remove the vent cap and shine a flashlight into the vent. Remove any foreign material.
3. Check for evidence of excessive condensation. Continuous condensation can cause corrosion of caps, pipes, and fittings and can be caused by having excessive lateral runs, too many elbows, or exterior portions of the system being exposed to cold weather.
4. Inspect joints to verify that no pipe section or fitting has been disturbed and loosened. Check mechanical supports such as wall straps for rigidity.

TROUBLESHOOTING

Note: For additional help, visit DESA's technical service web site at www.desatech.com.

Note: All troubleshooting items are listed in order of operation.

⚠ WARNING: Turn off burner system and let cool before servicing. Only a qualified service person should service and repair heater.

⚠ CAUTION: Never use a wire, needle, or similar object to clean pilot. This can damage pilot unit.

OBSERVED PROBLEM	POSSIBLE CAUSE	REMEDY
When ignitor button is pressed, there is no spark at pilot	<ol style="list-style-type: none"> Ignitor electrode not connected to ignitor cable Ignitor cable pinched or wet Piezo ignitor nut is loose Broken ignitor cable Bad piezo ignitor Ignitor electrode broken Ignitor electrode positioned wrong 	<ol style="list-style-type: none"> Reconnect ignitor cable Free ignitor cable if pinched by any metal or tubing. Keep ignitor cable dry Tighten nut holding piezo ignitor. Nut is located behind the mounting bracket. Replace ignitor cable Replace piezo ignitor Replace pilot assembly Replace pilot assembly
When ignitor button is pressed, there is spark at pilot but no ignition	<ol style="list-style-type: none"> Gas supply turned off or equipment shutoff valve closed Control knob not in PILOT position Control knob not pressed in while in PILOT position Air in gas lines when installed Depleted gas supply (propane/LP models only) Pilot is clogged Gas regulator setting is not correct 	<ol style="list-style-type: none"> Turn on gas supply or open equipment shutoff valve Turn control knob to PILOT position Press in control knob while in PILOT position Continue holding down control knob. Repeat igniting operation until air is removed Contact local propane/LP gas company Clean pilot (see <i>Cleaning and Maintenance</i>, page 22) or replace pilot assembly Replace gas control
Pilot lights but flame goes out when control knob is released	<ol style="list-style-type: none"> Control knob not fully pressed in Control knob not pressed in long enough Equipment shutoff valve not fully open Control valve damaged 	<ol style="list-style-type: none"> Press in control knob fully After pilot lights, keep control knob pressed in 30 seconds Fully open equipment shutoff valve Replace control valve

TROUBLESHOOTING

Continued

OBSERVED PROBLEM	POSSIBLE CAUSE	REMEDY
Burner does not light after pilot is lit	<ol style="list-style-type: none"> 1. Burner orifice clogged 2. Inlet gas pressure is too low 3. Thermopile leads disconnected or improperly connected 4. Thermopile is defective 	<ol style="list-style-type: none"> 1. Clean burner (see <i>Cleaning and Maintenance</i>, page 22) or replace burner orifice 2. Contact local propane/LP or natural gas company 3. Reconnect leads (see <i>Wiring Diagram</i>, page 26) 4. Replace thermopile
Delayed ignition burner	<ol style="list-style-type: none"> 1. Manifold pressure is too low 2. Burner porting or orifice clogged 	<ol style="list-style-type: none"> 1. Contact local propane/LP or natural gas company 2. Clean burner (see <i>Cleaning and Maintenance</i>, page 22) or replace burner orifice
Burner backfiring during combustion	<ol style="list-style-type: none"> 1. Burner orifice is clogged or damaged 2. Damaged burner 3. Gas regulator defective 	<ol style="list-style-type: none"> 1. Clean burner (see <i>Cleaning and Maintenance</i>, page 22) or replace burner orifice 2. Replace damaged burner 3. Replace gas control
Slight smoke or odor during initial operation	<ol style="list-style-type: none"> 1. Residues from manufacturing processes and logs curing 	<ol style="list-style-type: none"> 1. Problem will stop after a few hours of operation
Heater produces a whistling noise when burner is lit	<ol style="list-style-type: none"> 1. Air in gas line 2. Dirty or partially clogged burner orifice 	<ol style="list-style-type: none"> 1. Operate burner until air is removed from line. Have gas line checked by local propane/LP or natural gas company 2. Clean burner (see <i>Cleaning and Maintenance</i>, page 22) or replace burner orifice
Glass soots	<ol style="list-style-type: none"> 1. Flame impingement on logs 2. Debris around burner air mixer 3. Poor drafting 	<ol style="list-style-type: none"> 1. Adjust the log set so that the flame does not excessively impinge on it 2. Inspect the opening at the base of the burner to see that it is NOT packed with any type of material 3. See <i>Troubleshooting Venting Problems</i>, Down Drafts section, page 12
Burner system produces a clicking/ticking noise just after burners are lit or shut off	<ol style="list-style-type: none"> 1. Metal expanding while heating or contracting while cooling 	<ol style="list-style-type: none"> 1. This is common. If noise is excessive, contact qualified service person
Remote does not function	<ol style="list-style-type: none"> 1. Battery is not installed or battery power is low 	<ol style="list-style-type: none"> 1. Replace 9-volt batteries in receiver and remote control

TROUBLESHOOTING

Continued

- ⚠ WARNING: If you smell gas**
- Shut off gas supply.
 - Do not try to light any appliance.
 - Do not touch any electrical switch; do not use any phone in your building.
 - Immediately call your gas supplier from a neighbor's phone. Follow the gas supplier's instructions.
 - If you cannot reach your gas supplier, call the fire department.

IMPORTANT: Operating burner system where impurities in air exist may create odors. Cleaning supplies, paint, paint remover, cigarette smoke, cements and glues, new carpet or textiles, etc., create fumes. These fumes may mix with combustion air and create odors. These odors will disappear over time.

OBSERVED PROBLEM	POSSIBLE CAUSE	REMEDY
Burner system produces unwanted odors	1. Gas leak. See Warning statement above	1. Locate and correct all leaks (see <i>Checking Gas Connections</i> , page 14)
Burner system shuts off in use	1. High or gusting winds 2. Low line pressure 3. Pilot is partially clogged 4. Glass too loose and air tight gasket leaks in corners after usage 5. Bad thermopile 6. Improper vent cap installation	1. Burner system has been tested for up to 40mph winds. However, extreme conditions may occur. See <i>Lighting Instructions</i> on page 19 2. Contact local propane/LP or natural gas company 3. Clean pilot (see <i>Cleaning and Maintenance</i> , page 22) 4. Tighten glass 5. Replace faulty component 6. Check for proper installation and freedom from debris or blockage
Gas odor even when control knob is in OFF position	1. Gas leak. See Warning statement above 2. Control valve defective	1. Locate and correct all leaks (see <i>Checking Gas Connections</i> , page 14) 2. Replace control valve
Gas odor during combustion	1. Gas leak. See Warning statement above	1. Locate and correct all leaks (see <i>Checking Gas Connections</i> , page 14)
Dark residue on logs or inside of burner system	1. Improper log placement 2. Air holes at burner inlet blocked 3. Burner flame holes blocked 4. Poor drafting	1. Properly locate logs (see <i>Installing Logs, Lava Rock, and Glowing Embers</i> , page 18) 2. Clean out air holes at burner inlets. Periodically repeat as needed 3. Remove blockage or replace burner 4. See <i>Troubleshooting Venting Problems, Down Drafts</i> section, page 12

REPLACEMENT PARTS

Note: Use only original replacement parts. This will protect your warranty coverage for parts replaced under warranty.

PARTS UNDER WARRANTY

Contact authorized dealers of this product. If they can not supply original replacement part(s), call DESA's Technical Service Department at 1-866-672-6040.

When calling DESA, have ready

- your name
- your address
- model and serial numbers of your stove and burner system
- how burner system was malfunctioning
- type of gas used (propane/LP or natural gas)
- purchase date

Usually, we will ask you to return the part to the factory.

PARTS NOT UNDER WARRANTY

Contact authorized dealers of this product. If they can not supply original replacement part(s), call DESA at 1-866-672-6040 for referral information.

When calling DESA, have ready

- model number of your stove and burner system
- the replacement part number

TECHNICAL SERVICE

You may have further questions about installation, operation, or troubleshooting. If so, contact DESA's Technical Service Department at 1-866-672-6040. When calling, please have your model and serial numbers of your heater ready.

You can also visit DESA's technical service web site at www.desatech.com.

WIRING DIAGRAM

CAUTION: Label all wires prior to disconnection when servicing controls. Wiring errors can cause improper and dangerous operation. Verify proper operation after servicing.

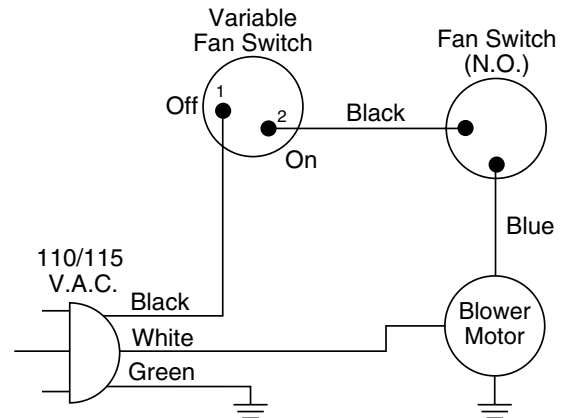

Figure 53 - Blower Wiring Diagram for Thermostat-Controlled Models

SERVICE HINTS

When Gas Pressure is Too Low:

- pilot will not stay lit
- burners will have delayed ignition
- burner system will not produce specified heat
- propane/LP gas supply might be low (propane/LP units only)

You may feel your gas pressure is too low. If so, contact your local natural or propane/LP gas supplier.

SPECIFICATIONS

	SBVBN(D)	SBVBP(D)
	30,000 Btu/h	28,000 Btu/h
Gas Type	Natural	Propane/LP
Ignition	Piezo	Piezo
Manifold Pressure	3.5" w.c.	10.0" w.c.
Minimum Inlet Supply Pressure	5.0" w.c.	11.0" w.c.
Thermal Efficiency	70%	70%
Dimension, Inches/mm (HxWxD) Stove and Burner System	27" x 21 1/2" x 18" 68.6 x 54.6 x 45.7 cm	27" x 21 1/2" x 18" 68.6 x 54.6 x 45.7 cm
Carton (Insert Only)	23 3/4" x 33 1/2" x 23 1/2" 60.3 x 85.1 x 59.7 cm	23 3/4" x 33 1/2" x 23 1/2" 60.3 x 85.1 x 59.7 cm
Weight, lbs/kg Burner System	70 lbs/31.8 kg	70 lbs/31.8 kg
Shipping	75 lbs/34 kg	75 lbs/34 kg

ILLUSTRATED PARTS BREAKDOWN

MODELS
SBVBN(D) AND SBVBP(D)

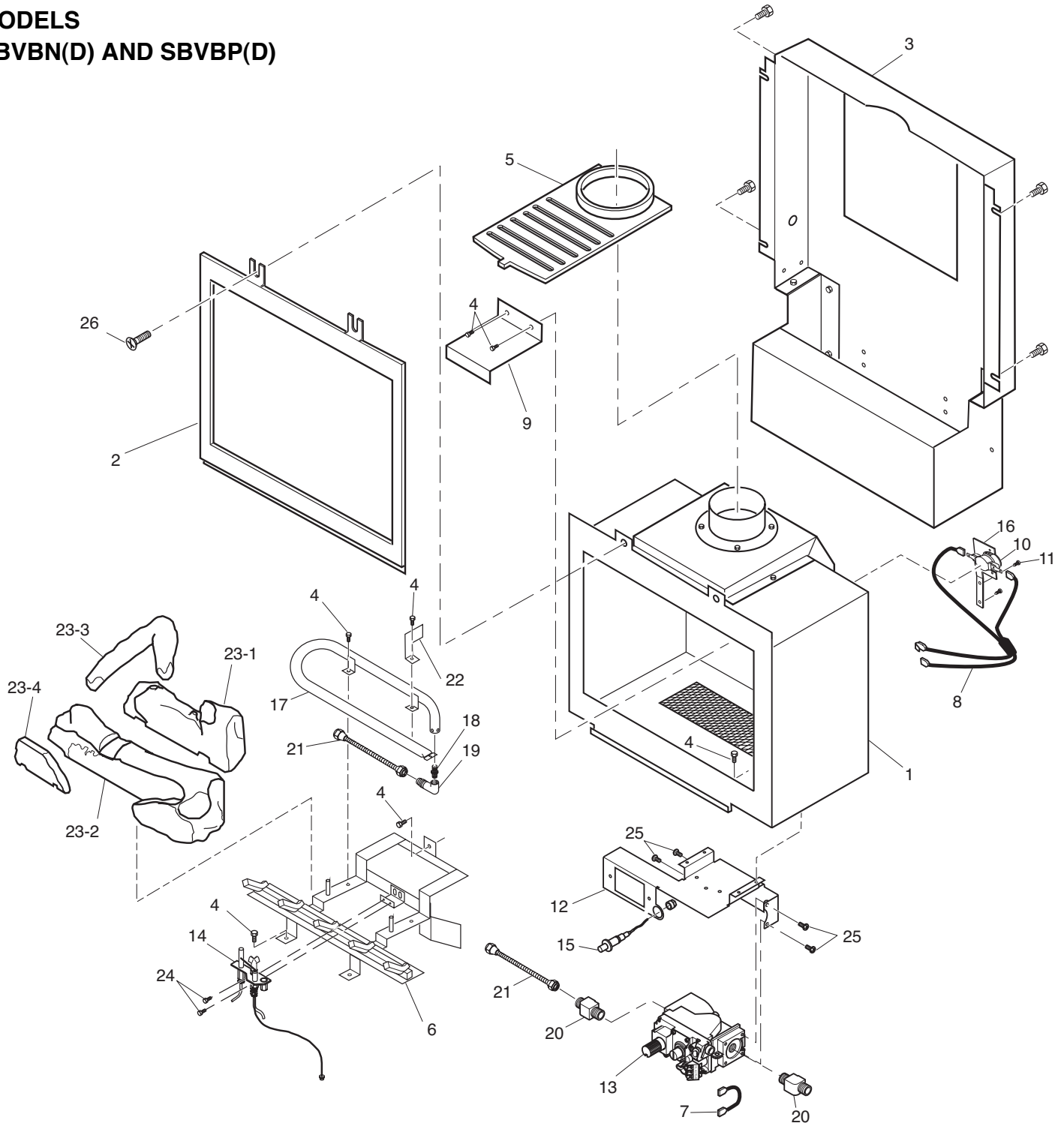

For more information, visit www.desatech.com

PARTS LIST

MODELS

SBVBN(D) AND SBVBP(D)

This list contains replaceable parts used in your burner system.
 When ordering parts, follow the instructions listed under *Replacement Parts* on page 26 of this manual.

KEY NO.	PART NUMBER	DESCRIPTION	QTY.
1	**	Firebox Assembly	1
2	105795-01	Glass Door Assembly	1
3	106831-02CK	Rear Cover	1
4	M11084-46	Screw, Hex	19
5	107013-01	Center Cast Grate	1
6	106794-01CK	Grate Assembly	1
7	101480-12	Wire Harness	1
8	103284-09	Wire Harness	1
9	107191-01	Baffle	1
10	105494-02	Spillswitch	1
11	M11084-43	Switch Screw	2
12	105468-02	Valve Bracket	1
13	112051-01	Valve, Natural	1
	112051-02	Valve, Propane/LP	1
14	105488-01	Pilot Assembly, Natural	1
	105488-02	Pilot Assembly, Propane/LP	1
15	102445-01	Ignitor, Piezo	1
16	107195-01	Bracket, Spill Switch	1
17	106036-01	Burner, Natural	1
	106036-02	Burner, Propane/LP	1
18	104506-16	Orifice, Natural	1
	104506-17	Orifice, Propane/LP	1
19	104507-01	Brass Elbow	1
20	112050-01	Brass Fitting	2
21	101628-04	Flex Tubing	2
22	105325-01	Air Deflector	1
23	105491-01	Log Set	1
23-1	105774-01	Rear Log	1
23-2	105774-02	Front Log	1
23-3	105774-03	Crossover Log	1
23-4	105774-04	Log Piece	1
24	098304-03	Screw	2
25	M12461-25	Screw	4
26	M12461-73	Screw	2
PARTS AVAILABLE - NOT SHOWN			
	GA6060	Lava Rock	1
	112044-01	Ember Material Bag	1
	112043-01	Blower Bracket Screw Assembly	1

**Not a field replaceable part.

ILLUSTRATED PARTS BREAKDOWN

AMITY™

SCIVF(*) AND PSCIVF(*) SERIES

VICTOR HEARTH™

VH(*) SERIES

OXFORD™

VCIS(*) AND PVCIS(*) SERIES

(* Indicates Color Suffix Designation)

Oxford™
Stove Body

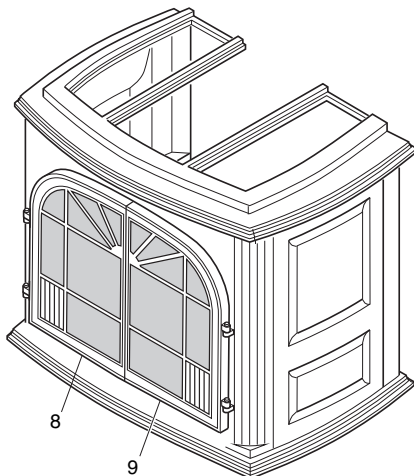
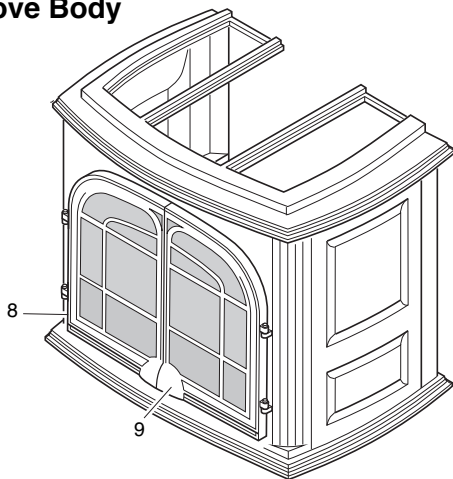

Victor Hearth™
Stove Body

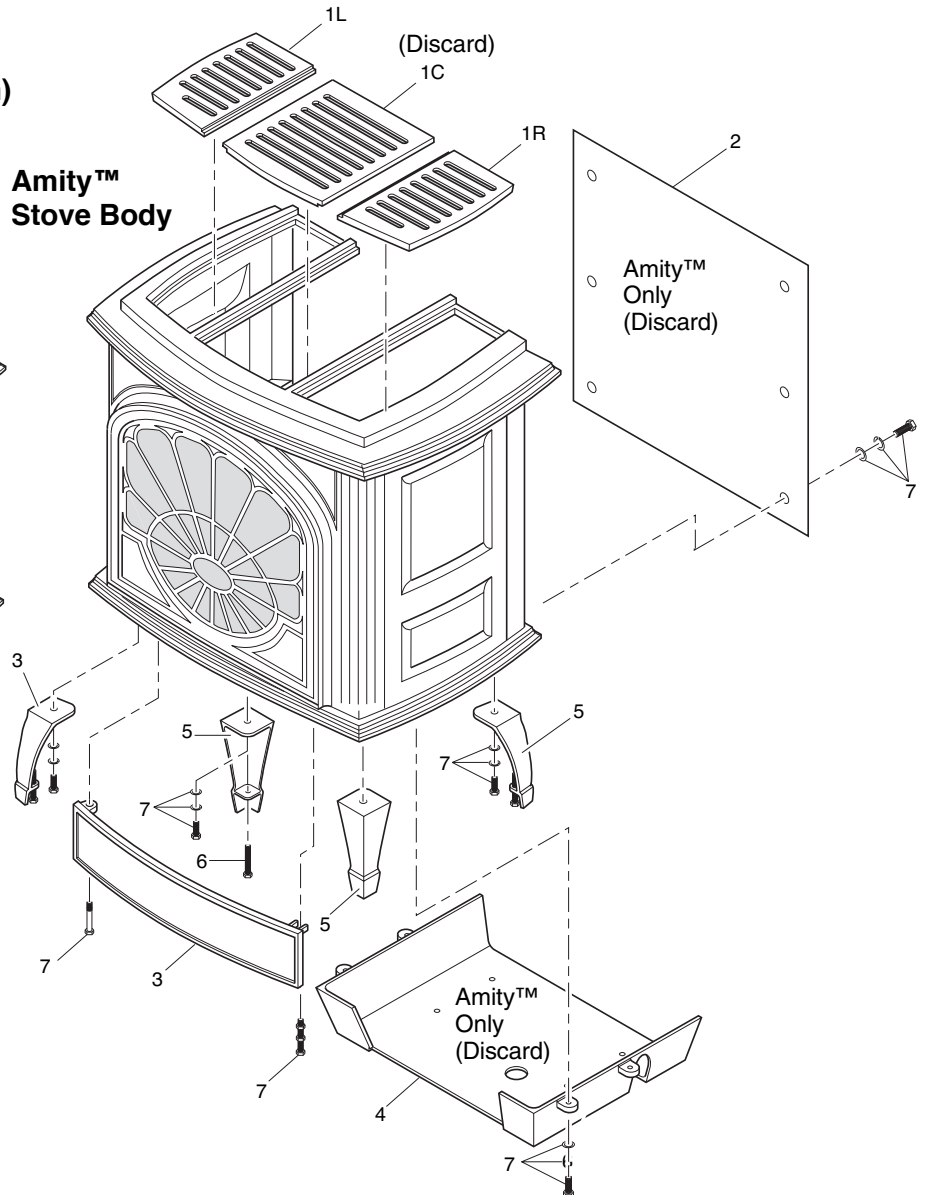

For more information, visit www.desatech.com

PARTS LIST

AMITY™ SCIVF(*) AND PSCIVF(*) SERIES

VICTOR HEARTH™ VH(*) SERIES

OXFORD™ VCIS(*) AND PVCIS(*) SERIES

(* Indicates Color Suffix Designation)

This list contains replaceable parts used in your stove. When ordering parts, follow the instructions listed under *Replacement Parts* on page 26 of this manual.

KEY NO.	PART NO.			DESCRIPTION	QTY.
	Amity™	Victor Hearth™	Oxford™		
1C	**	**	**	Top Grate with Screen, Center (Black Only)	1
1L	104171-11	104171-11	104171-11	Top Grate with Screen, Left (Black Only)	1
1R	104171-12	104171-12	104171-12	Top Grate with Screen, Right (Black Only)	1
2	**	----	----	Amity Stove Back Panel (Black Only)	1
3	104173-01	104173-01	104173-01	Bottom Door (Charcoal)	1
	104173-07	104173-07	104173-07	Bottom Door (Porcelain Enamel Red)	1
	104173-08	104173-08	104173-08	Bottom Door (Porcelain Enamel Green)	1
	104173-09	104173-09	104173-09	Bottom Door (Porcelain Enamel Sand)	1
	104173-23	104173-23	104173-23	Bottom Door (Porcelain Enamel Black)	1
4	**	----	----	Amity Stove Dropped Bottom	1
5	104175-01	104175-01	104175-01	One Leg (Charcoal) (4 Total Per Stove)	1
	104175-07	104175-07	104175-07	One Leg (Porcelain Enamel Red) (4 Total Per Stove)	1
	104175-08	104175-08	104175-08	One Leg (Porcelain Enamel Green) (4 Total Per Stove)	1
	104175-09	104175-09	104175-09	One Leg (Porcelain Enamel Sand) (4 Total Per Stove)	1
	104175-44	104175-44	104175-44	One Leg (Porcelain Enamel Black) (4 Total Per Stove)	1
6	104176-01	104176-01	104176-01	Leg Leveler bolt M8 x 1.25 - 55mm Long (4 Total Per Stove)	1
7	104177-01	104177-02	104177-02	Hardware Kit	1
8	----	111972-01	113086-01	Left Door, Charcoal Black	1
	----	111972-02	113086-02	Left Door, Porcelain Enamel Black	1
	----	111972-03	113086-03	Left Door, Porcelain Enamel Green	1
	----	----	113086-04	Left Door, Red	1
	----	----	113086-05	Left Door, Sand	1
9	----	111972-04	113087-01	Right Door, Charcoal Black	1
	----	111972-05	113087-02	Right Door, Porcelain Enamel Black	1
	----	111972-06	113087-03	Right Door, Porcelain Enamel Green	1
	----	----	113087-04	Right Door, Red	1
	----	----	113087-05	Right Door, Sand	1
PARTS AVAILABLE – NOT SHOWN					
	104108-01	104108-01	104108-01	Touch-up Spray Paint 12 oz Can (Charcoal)	1
	104807-01	104807-01	104807-01	Touch-up Paint Bottle with Brush (Porcelain Enamel Red)	1
	104807-02	104807-02	104807-02	Touch-up Paint Bottle with Brush (Porcelain Enamel Green)	1
	104807-03	104807-03	104807-03	Touch-up Paint Bottle with Brush (Porcelain Enamel Sand)	1
	104807-04	104807-04	104807-04	Touch-up Paint Bottle with Brush (Porcelain Enamel Black)	1

** Not a field replaceable part.

ACCESSORIES

Purchase these stove and burner system accessories from your local dealer. If they can not supply these accessories, call DESA's Sales Department at 1-866-672-6040 for information. You can also write to the address listed on the back page of this manual.

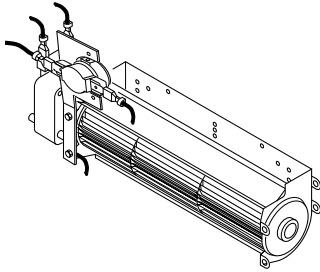

THERMOSTATICALLY- CONTROLLED BLOWER KIT - CDA3620TB

For all models. Provides better heat distribution. Blower turns off and on automatically, as needed. Complete installation and operation instructions included in this manual.

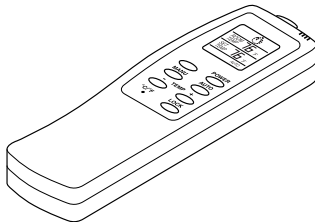

RECEIVER AND HAND-HELD THERMOSTAT REMOTE CONTROL KIT - GHRCTB AND CGHRCTB

For all Remote-Ready Models. Allows the gas log heater to be operated in a manually or thermostatically controlled mode. You can turn the gas log heater on and off without ever leaving the comfort of your easy chair.

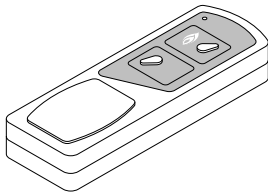

RECEIVER AND HAND-HELD REMOTE CONTROL KIT - GHRCB AND CGHRCB

For all Remote-Ready Models. Allows the gas log heater to be turned on and off by using a hand-held remote control.

WALL MOUNTED THERMOSTAT CONTROL KIT - GWMT1 (Not Shown)

For all models. Allows easy wall access to the operation of your burner system. This will allow you thermostatic control with the convenience of a wall switch.

WALL MOUNTED ON/OFF SWITCH - GWMS2 (Not Shown)

For all models. Allows burner system to be turned on and off with a wall switch.

NCBV-PS CONVERSION KIT (Not Shown)

For propane/LP gas models. Allows burner system to be converted from propane/LP gas to natural gas.

PCBV-NS CONVERSION KIT (Not Shown)

For natural gas models. Allows burner system to be converted from natural gas to propane/LP gas.

STOVE HEARTH BASE - GC10SPA (Not Shown)

For all models. Hearth base stained oak finish. Required when stove is placed on carpet. Dimensions 4" x 35 3/4" x 30 1/2" (H x W x D).

OWNER'S REGISTRATION FORM

In order to provide better customer service for this and future purchases, we recommend that you register your product with us. You can register online at www.desatech.com. If access to our website is not available to you, please complete this Owner's Registration Form and mail to the address on the back of this owner's manual. Please provide the following product information:

Brand: _____ (Comfort Glow, Vanguard, etc.)
 Model: _____ (EFP33PR, VTGH33NR, etc.)
 Date Purchased: _____ *Note: Keep receipt for warranty verification.*
 Serial Number: _____ 7 or 9 digit number located on product or identification tag.
 First Name: _____ Last Name: _____
 Address: _____
 City: _____ State: _____ Zip: _____ Country: _____
 Home Phone: _____
 E-Mail: _____

Please answer the following questions to register your product with DESA:

1. Where will the product be used?
 Living/Family Room Office/Warehouse Utility Shed/Outbuilding Garage Bedroom Bathroom Other
2. If you bought this product yourself, did you plan to purchase this type of product before going into the store? Yes No
3. Who selected the product? Male Female Both
4. What is the population of your area? Under 10,000 10,000 to 25,000 25,000 to 50,000 50,000 to 100,000
 100,000 to 250,000 Over 250,000
5. What is your primary source of heat? Propane (LP Gas) Fuel Oil Wood Natural Gas Electric Other
6. How was the product installed? Professional Installer Self Other
7. Cost of product excluding sales tax? \$ _____
8. Cost to install product? \$ _____
9. Type of store where product was purchased? Hardware Propane Dealer Natural Gas/Utility Co. Home Center/Builder's Supply
 Fireplace or Hearth Shop Farm Store Other
10. What motivated you to buy this product? Sudden Cold Weather Replace Older Model D.I.Y. Home Project
 Emergency Back-Up Heat Heater was on Sale Energy Savings/High Efficiency Construction Project Other
11. How did you learn about this product brand? Advertising Relative or Friend Store Display Other _____
12. Level of Education of Purchaser: Some High School Completed High School Completed College Completed Graduate School
13. Age of Purchaser: Under 20 20 - 29 30 - 39 40 - 49 50 - 59 60 or Over
14. Buyer's total annual household income: Under \$15,000 \$15,000 to \$19,999 \$20,000 to \$34,999 \$35,000 to \$49,999
 \$50,000 to \$74,999 \$75,000 to \$99,999 \$100,000 and Over

15. Store where product was purchased:
 Name: _____
 City: _____ State: _____

16. In choosing this product, how important were the following:

	Not Important	Somewhat Important	Very Important
Availability	<input type="radio"/>	<input type="radio"/>	<input type="radio"/>
Price	<input type="radio"/>	<input type="radio"/>	<input type="radio"/>
Brand Name	<input type="radio"/>	<input type="radio"/>	<input type="radio"/>
Overall Quality	<input type="radio"/>	<input type="radio"/>	<input type="radio"/>
Heat Output	<input type="radio"/>	<input type="radio"/>	<input type="radio"/>
Made in USA	<input type="radio"/>	<input type="radio"/>	<input type="radio"/>
Warranty	<input type="radio"/>	<input type="radio"/>	<input type="radio"/>
Local Service	<input type="radio"/>	<input type="radio"/>	<input type="radio"/>
Value for Price	<input type="radio"/>	<input type="radio"/>	<input type="radio"/>
Prior Brand Experience	<input type="radio"/>	<input type="radio"/>	<input type="radio"/>
Controls Location	<input type="radio"/>	<input type="radio"/>	<input type="radio"/>
Thermostat, Remote, or Manual Operation	<input type="radio"/>	<input type="radio"/>	<input type="radio"/>
Ease of Operation	<input type="radio"/>	<input type="radio"/>	<input type="radio"/>
Special Features	<input type="radio"/>	<input type="radio"/>	<input type="radio"/>
Salesperson's Recommendation	<input type="radio"/>	<input type="radio"/>	<input type="radio"/>
Friend/Relative's Recommendation	<input type="radio"/>	<input type="radio"/>	<input type="radio"/>
Portability	<input type="radio"/>	<input type="radio"/>	<input type="radio"/>
Quiet Operation	<input type="radio"/>	<input type="radio"/>	<input type="radio"/>

TAPE

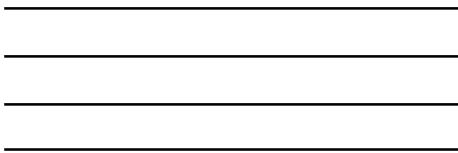

Postage
Required



2701 Industrial Drive
P.O. Box 90004
Bowling Green, KY 42102-9004

TAPE

WARRANTY INFORMATION

KEEP THIS WARRANTY

Burner System Model No. _____
Serial No. _____
Date Purchased _____

Cast Stove Model No. _____
Serial No. _____
Date Purchased _____

Always specify model and serial numbers when communicating with the factory.

We reserve the right to amend these specifications at any time without notice. The only warranty applicable is our standard written warranty. We make no other warranty, expressed or implied.

LIMITED WARRANTY

B-VENT BURNER SYSTEM PLUS AMITY™ AND VICTOR HEARTH™ STOVE CHASSIS

DESA warrants this product to be free from defects in materials and components for four (4) years from the date of first purchase, provided that the product has been properly installed, operated and maintained in accordance with all applicable instructions. To make a claim under this warranty the Bill of Sale or cancelled check must be presented.

This warranty is extended only to the original retail purchaser. This warranty covers the cost of part(s) required to restore this heater to proper operating condition and an allowance for labor when provided by a DESA Authorized Service Center. Warranty part(s) MUST be obtained through authorized dealers of this product and/or DESA who will provide original factory replacement parts. Failure to use original factory replacement parts voids this warranty. The heater MUST be installed by a qualified installer in accordance with all local codes and instructions furnished with the unit.

This warranty does not apply to parts that are not in original condition because of normal wear and tear, or parts that fail or become damaged as a result of misuse, accidents, lack of proper maintenance or defects caused by improper installation. Travel, diagnostic cost, labor, transportation and any and all such other costs related to repairing a defective heater will be the responsibility of the owner.

TO THE FULL EXTENT ALLOWED BY THE LAW OF THE JURISDICTION THAT GOVERNS THE SALE OF THE PRODUCT; THIS EXPRESS WARRANTY EXCLUDES ANY AND ALL OTHER EXPRESSED WARRANTIES AND LIMITS THE DURATION OF ANY AND ALL IMPLIED WARRANTIES, INCLUDING WARRANTIES OF MERCHANTABILITY AND FITNESS FOR A PARTICULAR PURPOSE TO FOUR (4) YEARS ON ALL COMPONENTS FROM THE DATE OF FIRST PURCHASE; AND DESA'S LIABILITY IS HEREBY LIMITED TO THE PURCHASE PRICE OF THE PRODUCT AND DESA SHALL NOT BE LIABLE FOR ANY OTHER DAMAGES WHATSOEVER INCLUDING INDIRECT, INCIDENTAL OR CONSEQUENTIAL DAMAGES.

Some states do not allow a limitation on how long an implied warranty lasts or an exclusion or limitation of incidental or consequential damages, so the above limitation on implied warranties, or exclusion or limitation on damages may not apply to you.

This warranty gives you specific legal rights, and you may also have other rights that vary from state to state.

For information about this warranty write:



2701 Industrial Drive
P.O. Box 90004
Bowling Green, KY 42102-9004
www.desatech.com



112127 01

NOT A UPC

112127-01
Rev. B
03/04

For more information, visit www.desatech.com

Free Manuals Download Website

<http://myh66.com>

<http://usermanuals.us>

<http://www.somanuals.com>

<http://www.4manuals.cc>

<http://www.manual-lib.com>

<http://www.404manual.com>

<http://www.luxmanual.com>

<http://aubethermostatmanual.com>

Golf course search by state

<http://golfingnear.com>

Email search by domain

<http://emailbydomain.com>

Auto manuals search

<http://auto.somanuals.com>

TV manuals search

<http://tv.somanuals.com>