

PORTABLE FORCED AIR HEATER

(WITH BUILT-IN THERMOSTAT)

OWNER'S MANUAL

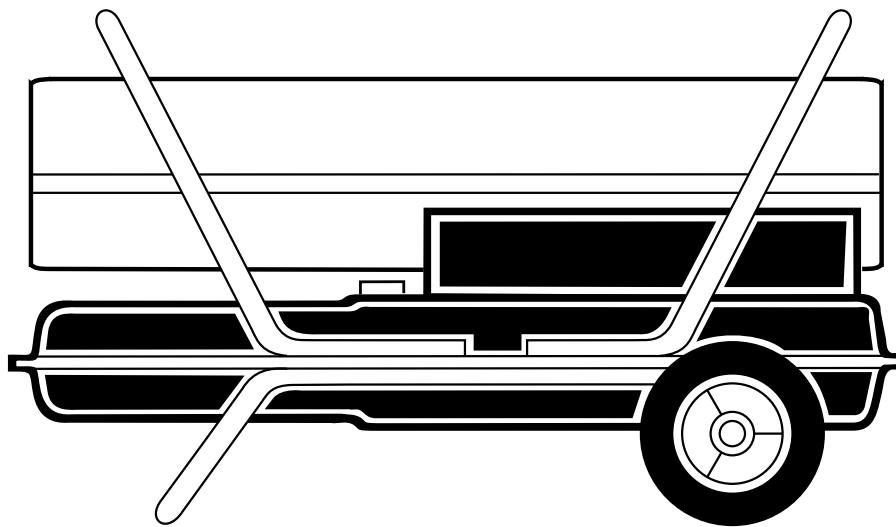

200,000 Btu/Hr

Model RM200T

IMPORTANT: Read and understand this manual before assembling, starting, or servicing heater. Improper use of heater can cause serious injury. Keep this manual for future reference.



200,000 BTU/HR

PORTABLE FORCED AIR HEATER

SAFETY INFORMATION



WARNINGS

IMPORTANT: Read this Owner's Manual carefully and completely before trying to assemble, operate, or service this heater. Improper use of this heater can cause serious injury or death from burns, fire, explosion, electrical shock, and carbon monoxide poisoning.



DANGER: Carbon monoxide poisoning may lead to death!

Carbon Monoxide Poisoning: Early signs of carbon monoxide poisoning resemble the flu, with headaches, dizziness, and/or nausea. If you have these signs, the heater may not be working properly. **Get fresh air at once!** Have heater serviced. Some people are more affected by carbon monoxide than others. These include pregnant women, persons with heart or lung disease or anemia, those under the influence of alcohol, and those at high altitudes.

Make certain you read and understand all Warnings. Keep this manual for reference. It is your guide to safe and proper operation of this heater.

- Use only kerosene or No. 1 fuel oil to avoid risk of fire or explosion. Never use gasoline, naphtha, paint thinners, alcohol, or other highly flammable fuels.
- Fueling
 - a) Personnel involved with fueling shall be qualified and thoroughly familiar with the manufacturer's instructions and applicable federal, state, and local regulations regarding the safe fueling of heating units.
 - b) Only the type of fuel specified on the heater's data plate shall be used.
 - c) All flame, including the pilot light, if any, shall be extinguished and the heater allowed to cool, prior to fueling.
 - d) During fueling, all fuel lines and fuel-line connections shall be inspected for leaks. Any leaks shall be repaired prior to returning the heater to service.
 - e) At no time shall more than one day's supply of heater fuel be stored inside a building in the vicinity of the heater. Bulk fuel storage shall be outside the structure.
 - f) All fuel storage shall be located a minimum of 25 feet from heaters, torches, welding equipment, and similar sources of ignition (exception: the fuel reservoir integral with the heater unit).
 - g) Whenever possible, fuel storage shall be confined to areas where floor penetrations do not permit fuel to drip onto or be ignited by a fire at lower elevation.
 - h) Fuel storage shall be in accordance with the federal, state, or local authority having jurisdiction.
- Never use heater where gasoline, paint thinner, or other highly flammable vapors are present.
- Follow all local ordinances and codes when using heater.
- Heaters used in the vicinity of tarpaulins, canvas, or similar enclosure materials shall be located a safe distance from such materials. The recommended minimum safe distance is 10 feet. It is further recommended that these enclosure materials be of a fire retardant nature. These enclosure materials shall be securely fastened to prevent them from igniting or from upsetting the heater due to wind action.
- Use only in well-vented areas. Before using heater, provide at least a three-square-foot opening of fresh, outside air for each 100,000 Btu/Hr of rating. This heater produces carbon monoxide, which is listed by the State of California as a reproductive toxin under Proposition 65.
- Use only in places free of flammable vapors or high dust content.
- Use only the electrical voltage and frequency specified on model plate.
- Use only a three-prong, grounded extension cord.
- Minimum heater clearances from combustibles:

Outlet: 8 Ft.	Sides: 4 Ft.
Top: 4 Ft.	Rear: 4 Ft.
- Locate heater on a stable and level surface if heater is hot or running or a fire may occur.
- When moving or storing heater, keep heater in a level position or fuel spillage may occur.
- Keep children and animals away from heater.
- Unplug heater when not in use.
- Heater is equipped with a thermostat. Heater may start anytime.
- Never use heater in living or sleeping areas.
- Never block air inlet (rear) or air outlet (front) of heater.
- Never move, handle, refuel, or service a hot, operating, or plugged-in heater.
- Never attach duct work to front or rear of heater.
- **Warning to New York City Residents For Use Only At Construction Sites** in accordance with applicable NYC codes under NYCFD certificate of approval #4803, #4899, #4908, #4909, or #4934.

OWNER'S MANUAL

PRODUCT IDENTIFICATION

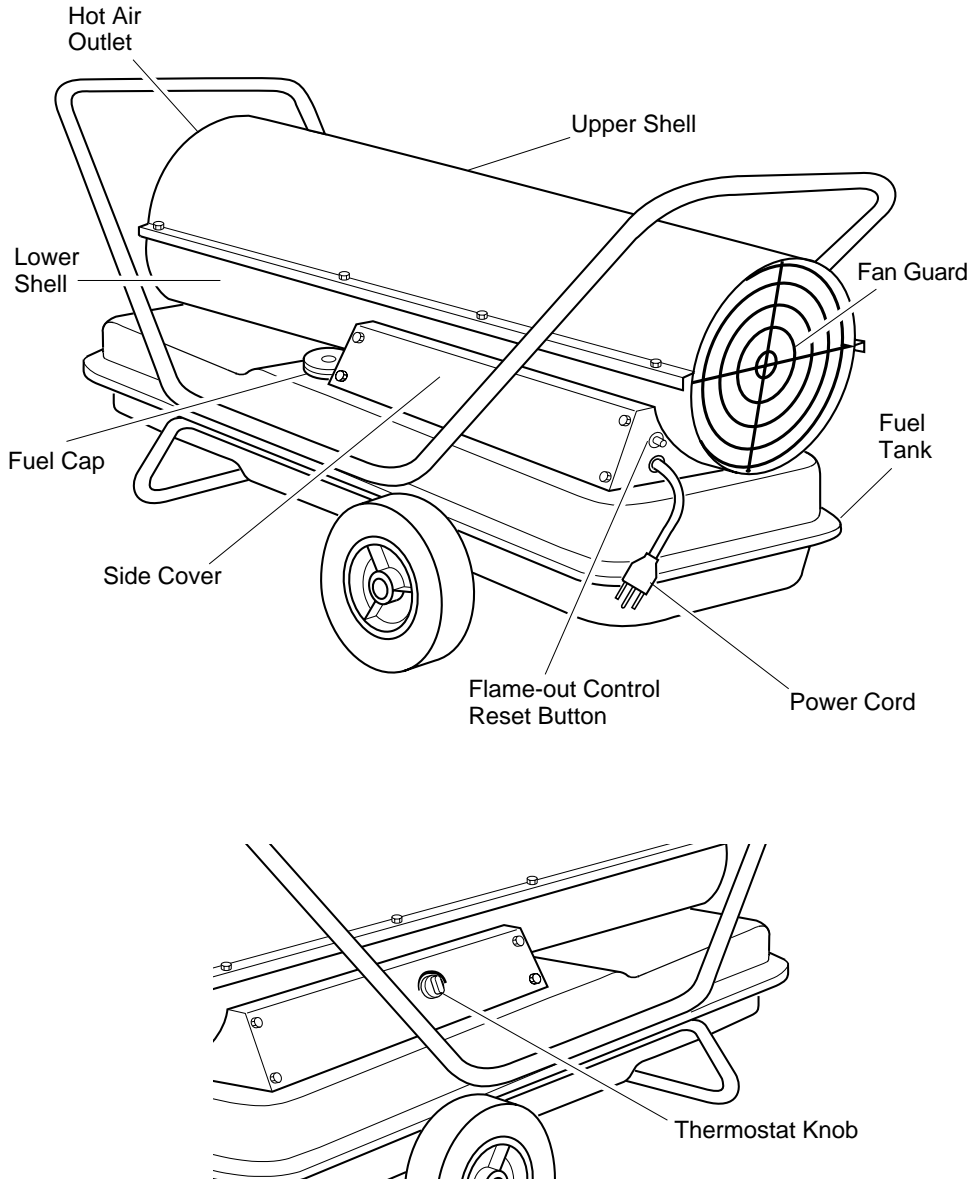

Figure 1 - RM200T Model

UNPACKING

1. Remove all packing items applied to heater for shipment.
2. Remove all items from carton.
3. Check items for shipping damage. If heater is damaged, promptly inform dealer where you bought heater.

200,000 BTU/HR

PORTABLE FORCED AIR HEATER

ASSEMBLY

This model is furnished with wheels and handles. Wheels, handles, and the mounting hardware are found in the shipping carton.

TOOLS NEEDED

- Medium Phillips Screwdriver
- 3/8" Open or Adjustable Wrench
- Hammer

1. Slide axle through wheel support frame. Install wheels on axle.
IMPORTANT: When installing wheels, point extended hub of wheels toward wheel support frame (see Figure 2).

2. Place cap nuts on axle ends. Gently tap with hammer to secure.
3. Place heater on wheel support frame. Make sure air inlet end (rear) of heater is over wheels. Line up holes on fuel tank flange with holes on wheel support frame.
4. Place handles on top of fuel tank flange. Insert screws through handles, fuel tank flange, and wheel support frame. Attach nut finger tight after each screw is inserted.
5. After all screws are inserted, tighten nuts firmly.

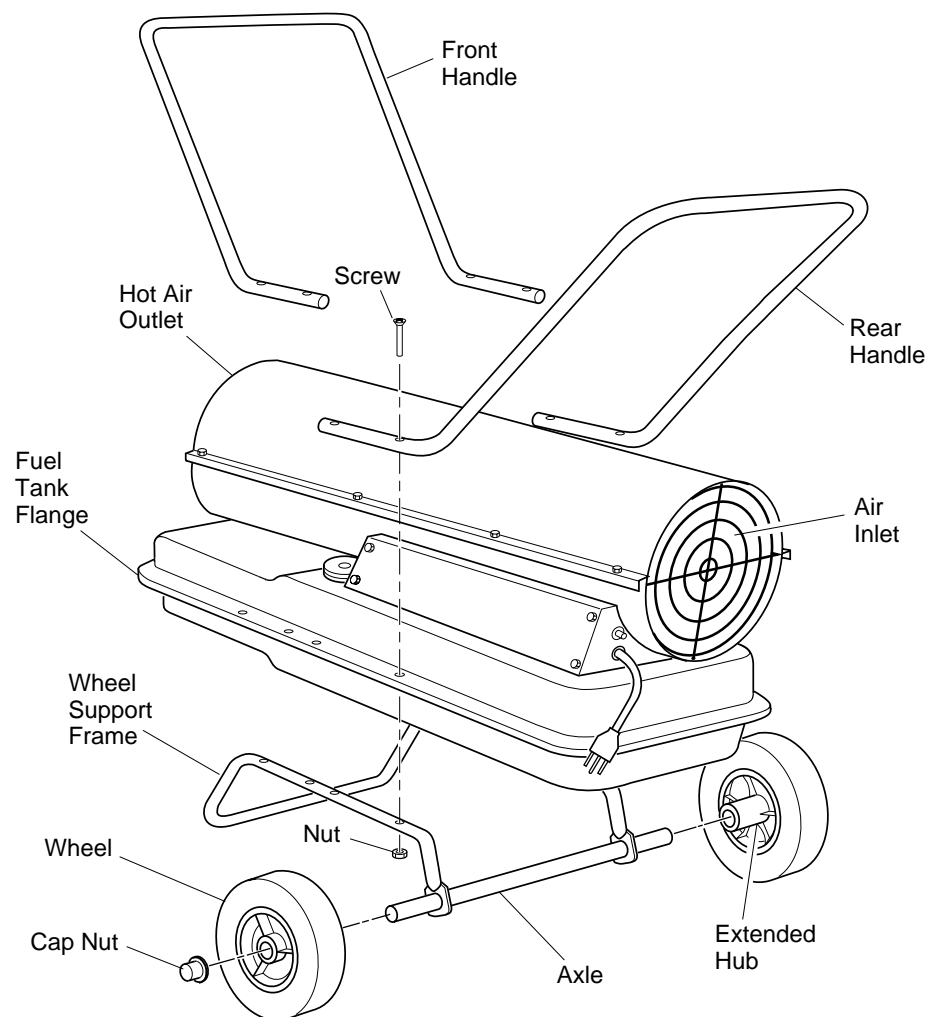

Figure 2 - Wheel and Handle Assembly

FUELS

⚠ WARNING: Use only kerosene or No. 1 fuel oil to avoid risk of fire or explosion. Never use gasoline, naphtha, paint thinners, alcohol, or other highly flammable fuels.

Do not use heavy fuels such as No. 2 fuel oil or No. 2 Diesel. Using heavy fuels will result in:

- clogged fuel filter and nozzle
- carbon build up on spark plug
- the need of nontoxic anti-icer in fuel during very cold weather

IMPORTANT: Use a KEROSENE ONLY storage container. Be sure storage container is clean. Foreign matter such as rust, dirt, or water will cause the flame-out control to shut down heater. Foreign matter may also require you to clean fuel system often.

VENTILATION

⚠ WARNING: Follow the minimum fresh, outside air ventilation requirements. If proper fresh, outside air ventilation is not provided, carbon monoxide poisoning can occur. Provide proper fresh, outside air ventilation before running heater.

Provide at least a three-square-foot opening of fresh, outside air for each 100,000 Btu/Hr rating. Provide extra fresh air if more heaters are being used.

Example: A 200,000 Btu/Hr heater requires one of the following:

- a two-car garage door (16 feet wide opening) raised five inches
- a single-car garage door (9 feet wide opening) raised eight inches
- two windows (30 inches wide opening) raised fifteen inches

OWNER'S MANUAL

THEORY OF OPERATION

The Fuel System: The air pump forces air through the air line. The air is then pushed through the burner head nozzle. This air causes fuel to lift from the tank. A fine mist of fuel is sprayed into the combustion chamber.

The Air System: The motor turns the fan. The fan pushes air into and around the combustion chamber. This air is heated and provides a stream of clean, hot air.

The Ignition System: The electronic ignitor sends voltage to the spark plug. The spark plug ignites the fuel and air mixture.

The Flame-out Control System: This system causes the heater to shut down if the flame goes out.

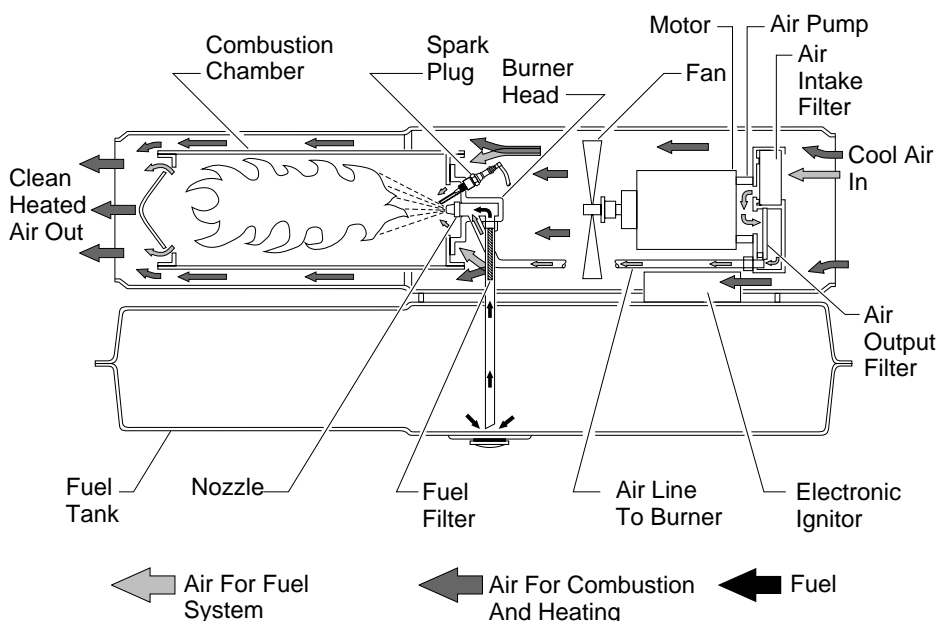

Figure 3 - Cross Section Operational View

OPERATION

⚠ WARNING: Review and understand the warnings in the *Safety Information* section, page 2. They are needed to safely operate this heater. Follow all local codes when using this heater.

TO START HEATER

1. Follow all ventilation and safety information.
2. Fill fuel tank with kerosene or No. 1 fuel oil.
3. Attach fuel cap.
4. Plug power cord of heater into three-prong, grounded extension cord. Extension cord must be at least six feet long.

Extension Cord Wire Size Requirements

- 6 to 10 feet long, use 18 AWG rated cord
11 to 100 feet long, use 16 AWG rated cord
101 to 200 feet long, use 14 AWG rated cord
5. Plug extension cord into standard 120 volt/60 hertz, three-hole, grounded outlet. Adjust thermostat to desired setting. If heater does not start, thermostat setting may be too low. Turn thermostat knob to higher position to start heater. If thermostat is in HIGH position and heater still will not start, push in flame-out control reset button (see Figure 4). *Note:* A cold heater may affect the thermostat setting. This thermostat is a general-heating control. It is not intended for precise temperature control. Adjust thermostat until heater cycles at the desired setting.

TO STOP HEATER

Unplug extension cord from outlet.

TO RESTART HEATER

1. Wait two minutes after stopping heater.
2. Repeat steps under *To Start Heater*.

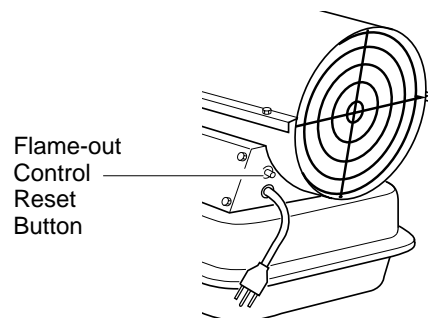

Figure 4 - Flame-out Control Reset Button

200,000 BTU/HR

PORTABLE FORCED AIR HEATER

STORING, TRANSPORTING, OR SHIPPING

Note: If shipping, transport companies require fuel tanks to be empty.

1. Drain fuel tank.

Note: This model has a drain plug on underside of fuel tank. Remove drain plug to drain all fuel. Be sure all fuel is removed.

2. Replace drain plug.
3. If any debris is noted in old fuel, add 1 or 2 quarts of clean kerosene to tank, stir, and drain again. This will prevent excess debris from clogging filters during future use.
4. Replace fuel cap and drain plug. Properly dispose of old and dirty fuel. Check with local automotive service stations that recycle oil.
5. If storing, store heater in dry place. Make sure storage place is free of dust and corrosive fumes.

IMPORTANT: Do not store kerosene over summer months for use during next heating season. Using old fuel could damage heater.

PREVENTATIVE MAINTENANCE SCHEDULE

Item	How Often	How To
Fuel tank	Flush every 150-200 hours of operation or as needed	See <i>Storing, Transporting, or Shipping</i>
Air output and lint filters	Replace every 500 hours of operation or once a year	See <i>Air Output, Air Intake, and Lint Filters</i> , page 8
Air intake filter	Wash and dry with soap and water every 500 hours of operation or replace as needed	See <i>Air Output, Air Intake, and Lint Filters</i> , page 8
Fuel filter	Clean twice a heating season or replace as needed	See <i>Fuel Filter</i> , page 9
Spark plug	Clean and regap every 600 hours operation or replace as needed	See <i>Spark Plug</i> , page 10
Fan blades	Clean each season or as needed	See <i>Fan</i> , page 8
Motor	Not required/permanently lubricated	

⚠ WARNING: Never service heater while it is plugged in, operating, or hot. Severe burns and electrical shock can occur.

OWNER'S MANUAL

TROUBLESHOOTING

Note: For additional help, visit DESA International's Technical Service web site at www.desatech.com.

 **WARNING:** Never service heater while it is plugged in, operating, or hot. Severe burns and electrical shock can occur.

OBSERVED FAULT	POSSIBLE CAUSE	REMEDY
Heater ignites, but flame-out control shuts off heater after a short period of time	<ol style="list-style-type: none">1. Wrong pump pressure2. Dirty air output, air intake and lint filters3. Dirty fuel filter4. Dirt in nozzle5. Dirty photocell lens6. Bad flame-out control	<ol style="list-style-type: none">1. See <i>Pump Pressure Adjustment</i>, page 82. See <i>Air Output, Air Intake and Lint Filters</i>, page 83. See <i>Fuel Filter</i>, page 94. See <i>Nozzle</i>, page 105. Clean photocell lens6. Replace flame-out control
Heater will not ignite, but motor runs for a short period of time	<ol style="list-style-type: none">1. Wrong pump pressure2. Improper spark plug gap/position or carbon deposits across gap3. Dirty fuel filter4. Dirt in nozzle5. Water in fuel tank6. Bad fuel valve	<ol style="list-style-type: none">1. See <i>Pump Pressure Adjustment</i>, page 82. See <i>Spark Plug</i>, page 103. See <i>Fuel Filter</i>, page 94. See <i>Nozzle</i>, page 105. Drain and flush fuel tank with clean kerosene. See <i>Storing, Transporting, or Shipping</i>, page 66. See <i>Fuel Valve</i>, page 9
 WARNING: High voltage!		
	<ol style="list-style-type: none">7. Electronic ignitor not grounded8. Bad electronic ignitor	<ol style="list-style-type: none">7. Make sure electronic ignitor mounting is tight8. Replace electronic ignitor
Motor does not start when heater is plugged in, fan rotates slowly or does not turn	<ol style="list-style-type: none">1. Flame-out control not reset2. Thermostat setting is too low3. Solid state relay not allowed to reset4. Binding pump rotor	<ol style="list-style-type: none">1. Press flame-out control reset button2. Turn thermostat knob to a higher setting.3. Wait two minutes before trying to re-start heater4. If fan is hard to turn, see <i>Pump Rotor</i>, page 11

200,000 BTU/HR

PORTABLE FORCED AIR HEATER

SERVICE PROCEDURES

⚠ WARNING: Never service heater while it is plugged in, operating, or hot. Severe burns and electrical shock can occur.

UPPER SHELL REMOVAL

1. Remove screws along each side of heater using 5/16" nut-driver. These screws attach upper and lower shells together.
2. Lift upper shell off.
3. Remove fan guard.

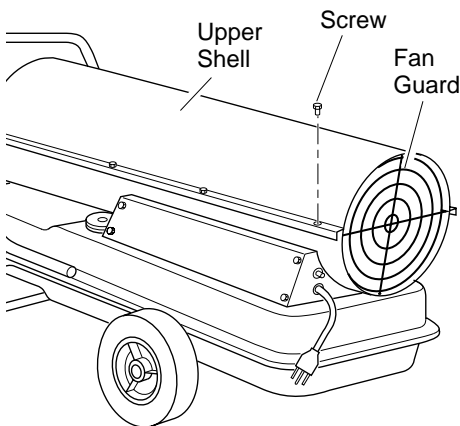

Figure 5 - Upper Shell Removal

FAN

IMPORTANT: Remove fan from motor shaft before removing motor from heater. The weight of the motor resting on the fan could damage the fan pitch.

1. Remove upper shell (see *Upper Shell Removal*, above).
2. Use 1/8" allen wrench to loosen set-screw which holds fan to motor shaft.
3. Slip fan off motor shaft.
4. Clean fan using soft cloth moistened with kerosene or solvent.
5. Dry fan thoroughly.
6. Replace fan on motor shaft. Place fan hub flush with end of motor shaft (see Figure 6).
7. Place setscrew on flat of shaft. Tighten setscrew firmly (40-50 inch-pounds).
8. Replace fan guard and upper shell.

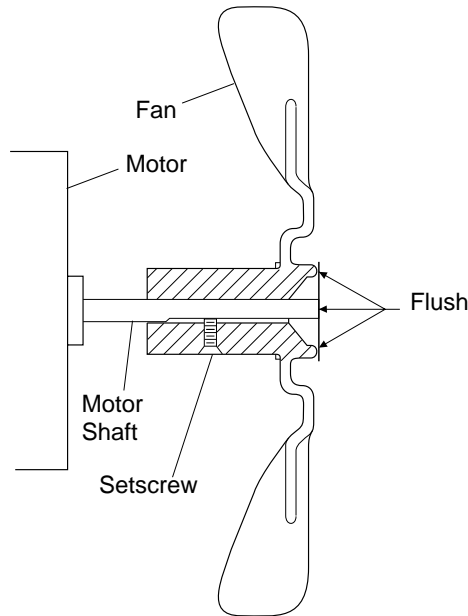

Figure 6 - Fan Cross Section

AIR OUTPUT, AIR INTAKE, AND LINT FILTERS

1. Remove upper shell (see *Upper Shell Removal*).
2. Remove filter end cover screws using 5/16" nut-driver.
3. Remove filter end cover.
4. Replace air output and lint filters.
5. Wash or replace air intake filter (see *Preventative Maintenance Schedule*, page 6).
6. Replace filter end cover.
7. Replace fan guard and upper shell.

IMPORTANT: Do not oil filters.

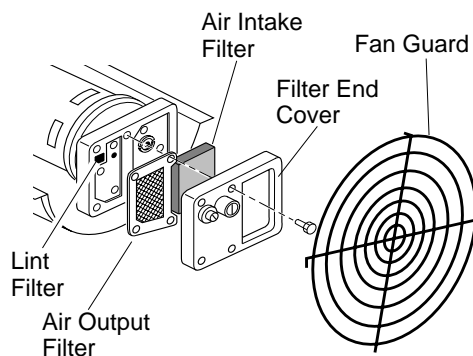

Figure 7 - Air Output, Air Intake, and Lint Filters

PUMP PRESSURE ADJUSTMENT

1. Remove pressure gauge plug from filter end cover (see Figure 8).
2. Install accessory pressure gauge (part number HA1180).
3. Start heater (see *Operation*, page 5). Allow motor to reach full speed.
4. Adjust pressure to 6.0 PSI. Turn relief valve to right to increase pressure. Turn relief valve to left to decrease pressure. See Figure 9.
5. Stop heater. Remove pressure gauge. Replace pressure gauge plug in filter end cover.

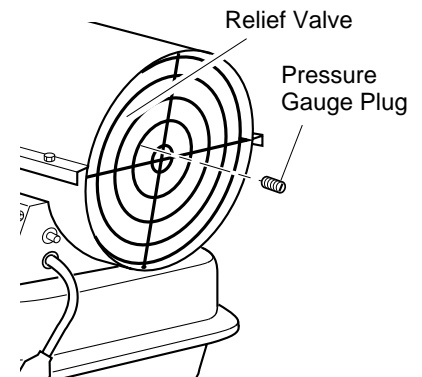

Figure 8 - Pressure Gauge Plug Removal

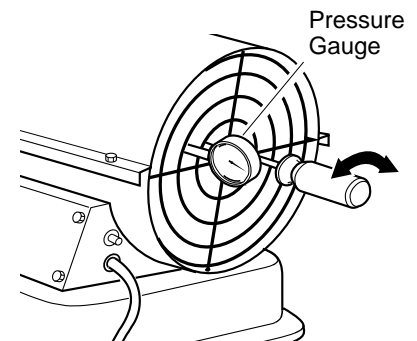

Figure 9 - Adjusting Pump Pressure

SERVICE PROCEDURES

Continued

FUEL FILTER

1. Remove side cover screws using 5/16" nut-driver.
2. Remove side cover.
3. Pull lower fuel line off the fuel valve fitting.
4. Carefully pry bushing, lower fuel line, and fuel filter out of fuel tank.
5. Wash fuel filter with clean fuel and replace in tank.
6. Attach lower fuel line to fuel valve fitting.
7. Replace side cover.

FUEL VALVE

1. Remove side cover (see Figure 10), fan guard, and upper shell (see Figure 5, page 8) screws using 5/16" nut-driver.
2. Remove fan (see *Fan*, page 8).
3. Pull lower fuel line off the fuel valve fitting (see Figure 11).

⚠ WARNING: High Voltage

4. Disconnect red and white wires from fuel valve. (see Figure 11).
5. Using 1/4" nut driver remove 2 screws/lockwashers holding fuel valve and bracket to lower shell (see Figure 11). Save these screws/lockwashers.
6. Using 1/4" nut driver remove 2 screws holding fuel valve to bracket. Save these screws.
7. Attach new fuel valve to bracket with 2 screws.
8. Install new fuel valve and bracket on lower shell with 2 screws/lockwashers.
9. Connect red and white wires (polarity not important). Connect upper and lower fuel lines to fuel valve (see Figure 11).
10. Replace fan, fan guard, upper shell, and side cover.

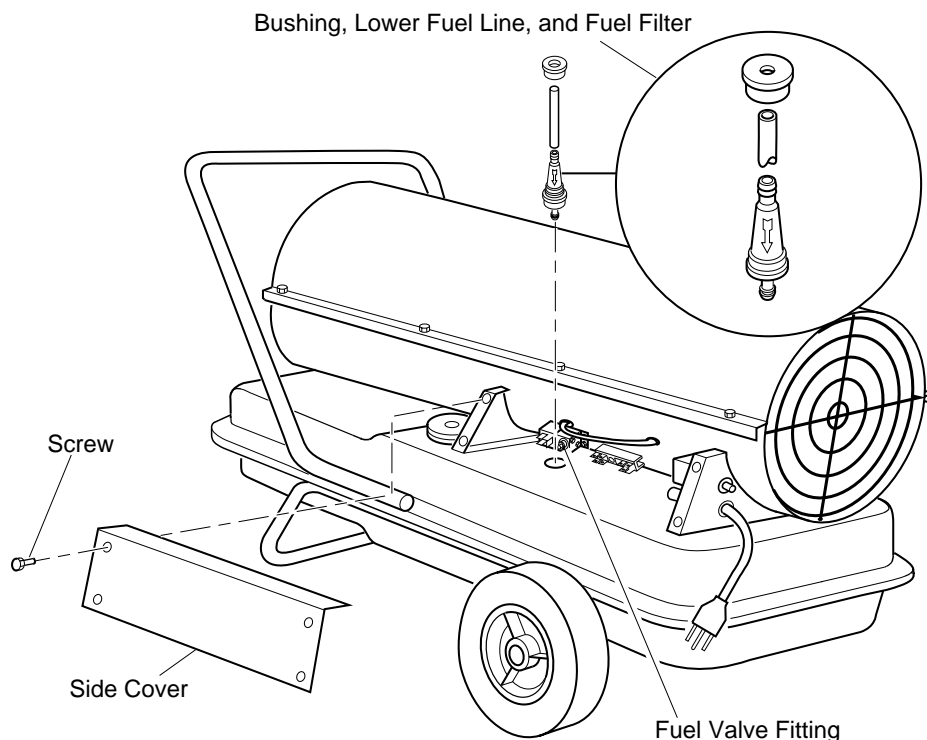

Figure 10 - Fuel Filter Removal

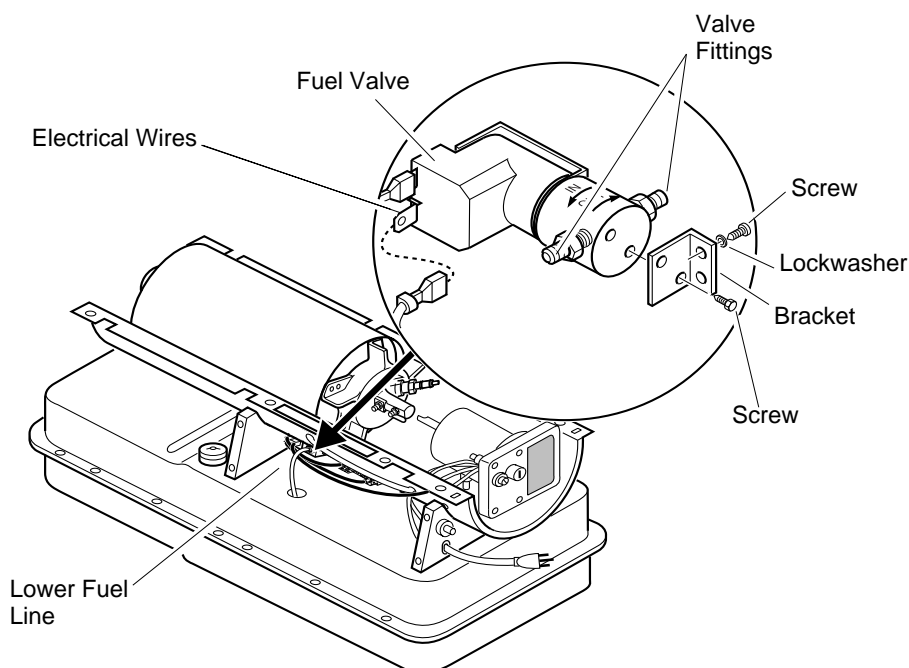

Figure 11 - Fuel Valve Replacement

Continued

200,000 BTU/HR

PORTABLE FORCED AIR HEATER

SERVICE PROCEDURES

Continued

SPARK PLUG

1. Remove upper shell (see *Upper Shell Removal*, page 8).
2. Remove fan (see *Fan*, page 8).
3. Remove spark plug wire from spark plug (see Figure 12).
4. Remove spark plug and wave spring washer from burner head using 13/16" open-end wrench.
5. Clean and regap spark plug electrodes to .110 gap (see Figure 13).
6. Install spark plug and wave spring washer in burner head. Torque 40 to 60 inch-pounds. Then adjust (if necessary) to bring side electrode into the acceptable range (see Figure 14).
7. Attach spark plug wire to spark plug.
8. Replace fan (see *Fan*, page 8).
9. Replace fan guard and upper shell (see *Upper Shell Removal*, page 8)

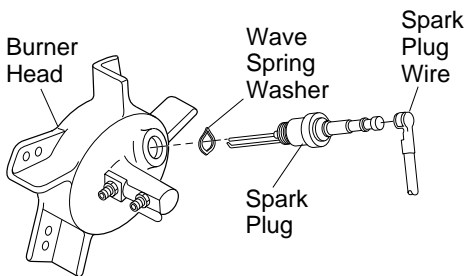

Figure 12 - Spark Plug Removal

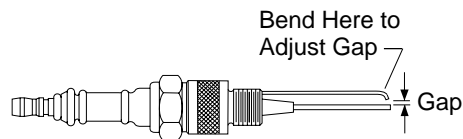

Figure 13 - Spark Plug Gap

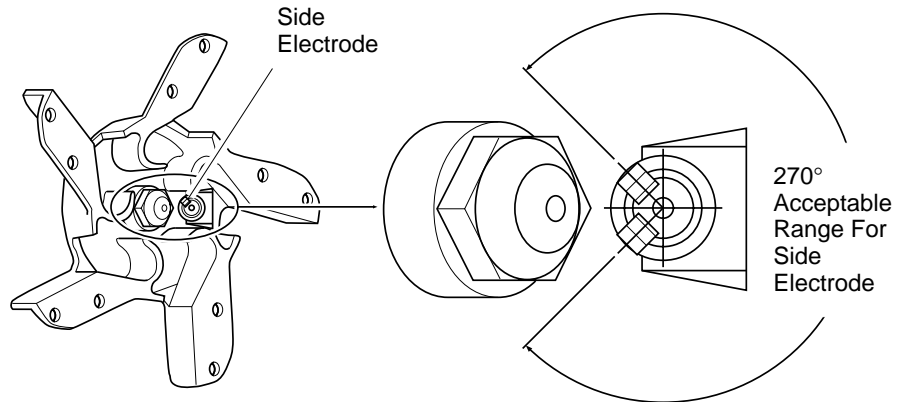

Figure 14 - Acceptable Range For Side Electrode

NOZZLE

1. Remove upper shell (see *Upper Shell Removal*, page 8).
2. Remove fan (see *Fan*, page 8).
3. Remove fuel and air line hoses from burner head.
4. Remove spark plug wire from spark plug.
5. Remove spark plug from burner head using 13/16" open-end wrench.
6. Remove three screws using 5/16" nut-driver and remove burner head from combustion chamber.
7. Place burner head into vise and lightly tighten.
8. Carefully remove nozzle from burner head using 5/8" socket wrench (see Figure 16, page 11).
9. Blow compressed air through face of nozzle. This will free any dirt in nozzle area.
10. Inspect nozzle seal for damage.
11. Replace nozzle into burner head and tighten firmly (80-110 inch-pounds).
12. Attach burner head to combustion chamber.
13. Install spark plug in burner head.
14. Attach spark plug wire to spark plug.
15. Attach fuel and airline hoses to burner head.
16. Replace fan (see *Fan*, page 8).
17. Replace fan guard and upper shell (see *Upper Shell Removal*, page 8).

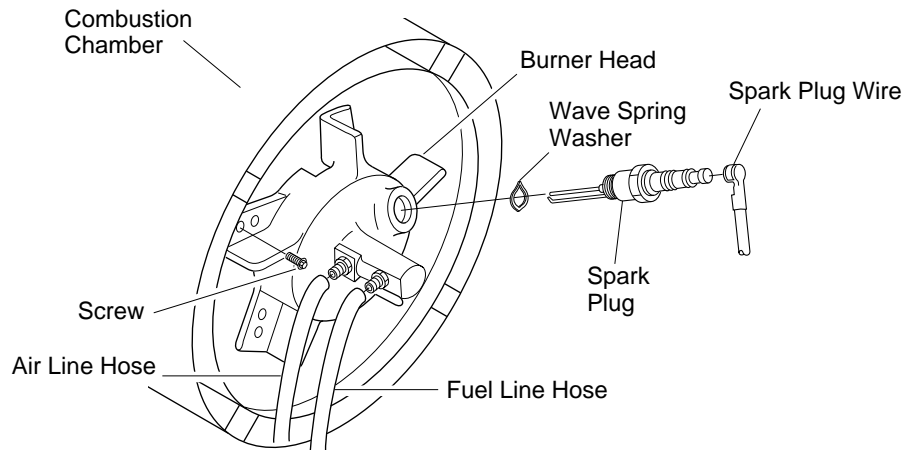

Figure 15 - Removing Burner Head

SERVICE PROCEDURES

Continued

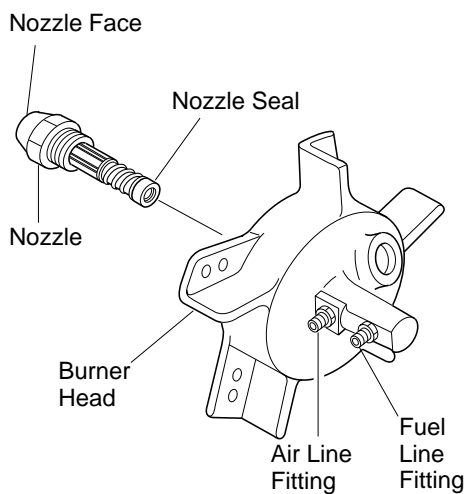

Figure 16 - Removing Nozzle

PUMP ROTOR (Procedure if Rotor is Binding)

1. Remove upper shell (see *Upper Shell Removal*, page 8).
2. Remove filter end cover screws using 5/16" nut-driver.
3. Remove filter end cover and air filters.
4. Remove pump plate screws using 5/16" nut-driver.
5. Remove pump plate.
6. Remove rotor, insert, and blades.
7. Check for debris in pump. If debris is found, blow out with compressed air.
8. Install insert and rotor.
9. Check gap on rotor. Adjust to .003"/.004" if needed (see Figure 18).

Note: Rotate rotor one full turn to insure the gap is .003"/.004" at tightest position. Adjust if needed.

10. Install blades, pump plate, air filters, and filter end cover.
11. Replace fan guard and upper shell.
12. Adjust pump pressure (see *Pump Pressure Adjustment*, page 8).

Note: If rotor is still binding, proceed as follows.

13. Perform steps 1 through 6 above.
14. Place fine grade sandpaper (600 grit) on flat surface. Sand rotor lightly in "figure 8" motion four times (see Figure 19).
15. Reinstall insert and rotor.
16. Perform steps 10 through 12 above.

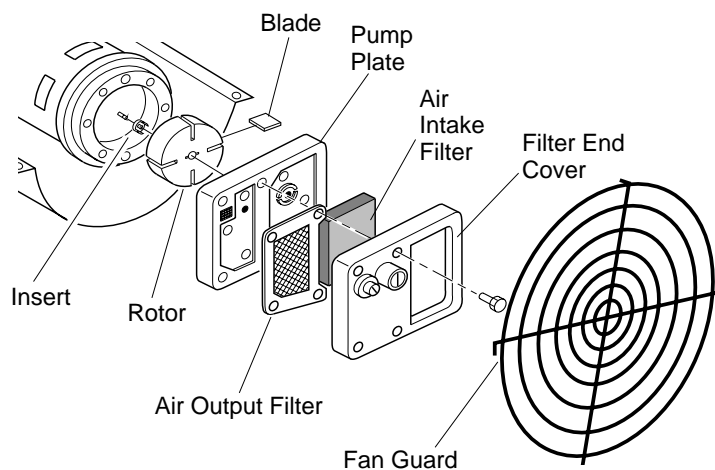

Figure 17 - Rotor Location

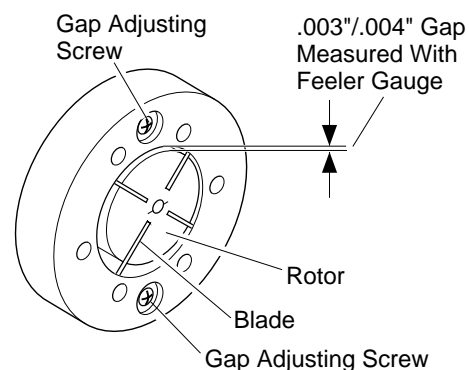

Figure 18 - Gap Adjusting Screw Locations

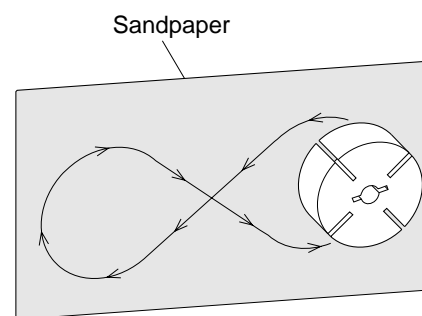
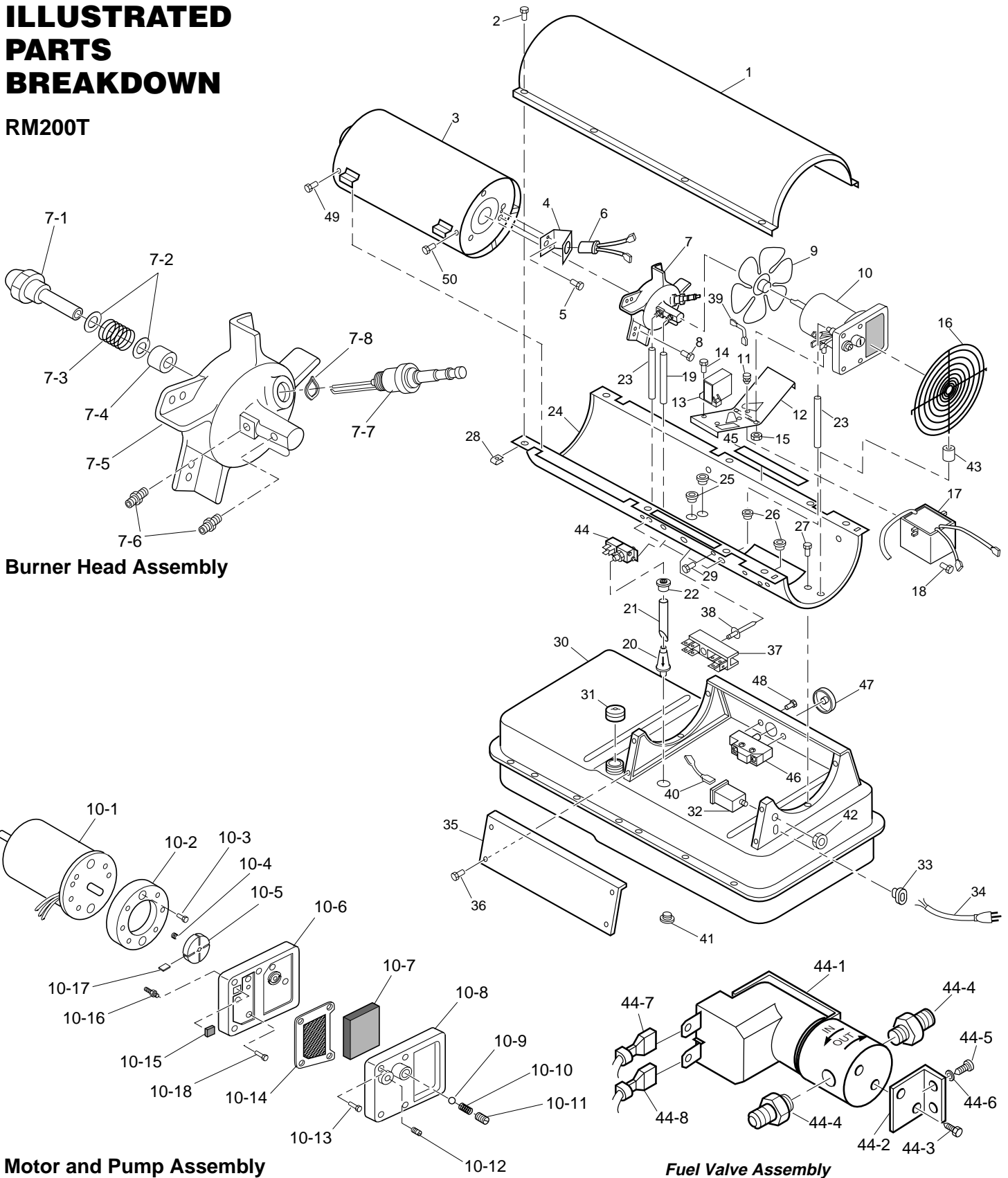

Figure 19 - Sanding Rotor

200,000 BTU/HR PORTABLE FORCED AIR HEATER

ILLUSTRATED PARTS BREAKDOWN

RM200T



OWNER'S MANUAL

PARTS LIST

RM200T

This list contains replaceable parts used in your heater. When ordering parts, be sure to provide the correct model and serial numbers (from the model plate), then the part number and description of the desired part.

KEY NO.	PART NUMBER	DESCRIPTION	QTY.	KEY NO.	PART NUMBER	DESCRIPTION	QTY.
1	098511-229	Upper Shell	1	26	M50104-01	Bushing	2
2	100647-01	Screw, #10-16 x 1/2"	8	27	M11084-27	Screw, #10-16 x 1/2"	6
3	098512-48	Combustion Chamber		28	M11271-8	Clip Nut	8
4	099229-01	Photocell Bracket	1	29	M10908-14	Screw, #8-32 x 3/8"	1
5	M10908-2	Screw, #6-32 x 3/8"	2	30	098513-88	Fuel Tank	1
6	HA3019	Photocell Assembly	1	31	097702-01	Fuel Cap (Includes Gasket)	1
7	***	Burner Head Assembly	1	32	HA3003	Flame-out Control	1
7-1	100735-13	Nozzle	1	33	M11143-1	Strain Relief Bushing	1
7-2	M10659-1	Nozzle Washer	2	34	098219-34	Power Cord	1
7-3	M10809-1	Nozzle Spring	1	35	102562-01AA	Side Cover	1
7-4	M8882	Nozzle Sleeve	1	36	M11084-27	Screw, #10-16 x 1/2"	4
7-5	M50924-08	Burner Head Body	1	37	099125-12	Terminal Board	1
7-6	M50820-02	Barb Fitting	2	38	099157-01	Rivet	1
7-7	HA3012	Spark Plug	1	39	079010-20	Wire Assembly (Red, 18")	1
7-8	103409-01	Washer, Wave Spring	1	40	M16841-57	Wire Assembly (Red, 6")	1
8	M11084-27	Screw, #10-16 x 1/2"	3	41	M27417	Drain Plug (Includes "o" Ring)	1
9	102042-01	Fan	1	42	099177-01	Hex Nut, 3/8 - 27	1
10	***	Motor and Pump Assembly	1	43	103523-01	Rubber Bushing	1
10-1	102001-07	Motor	1	44	***	Fuel Valve Assembly	1
10-2	079975-03	Pump Body	1	44-1	105939-01	Fuel Valve	1
10-3	FHPF3-6C	Screw, #10-32 x 5/8"	2	44-2	103129-01	Fuel Valve Bracket	1
10-4	M22009**	Rotor Insert	1	44-3	M12461-13	Hex Head Screw, 8-32 x 1/4"	2
10-5	M22456-2**	Pump Rotor	1	44-4	M50820-02	Fitting Barb	2
10-6	M50545	Pump End Cover	1	44-5	M11084-38	Hex TPG Screw, 8-18 x 3/8"	2
10-7	M12179**	Intake Filter	1	44-6	WLE-2	Lockwasher	2
10-8	M16545	Filter End Cover	1	44-7	079010-31	Wire Assembly, Red	1
10-9	M8940**	Steel Ball, 1/4" Diameter	1	44-8	079010-32	Wire Assembly, White	1
10-10	M10993-1**	Relief Spring	1	45	097785-04	Foam Gasket	2
10-11	M27694**	Adjusting Screw	1	46	097657-03	Thermostat	1
10-12	M22997**	Plug	1	47	104905-01	Thermostat Knob	1
10-13	M12461-31	Screw, #10-32 x 1"	4	48	M10908-1	Screws, #6-32 x 1/4"	2
10-14	M12244-1**	Output Filter	1	49	099230-01	Screws, Special	2
10-15	M11637**	Lint Filter	1	50	M11084-27	Screws, #10-16 x 1/2"	2
10-16	M50820-02	Barb Fitting	1	PARTS AVAILABLE - NOT SHOWN			
10-17	M8643-2**	Blade	4		099650-01	Clip (Secures Thermostat and Power Cord Wires)	1
10-18	M12461-32	Screw, #10-32 x 1.12"	6		098493-01	General Information Decal	1
11	M50631	Rubber Bumper	2		103474-01	Tradename Decal	2
12	101206-01	Motor Mounting Bracket	1		M9900-192	Combustion Chamber Grounding Wire	1
13	097061-01	Solid State Relay	1		100621-02	Thermostat Decal	1
14	M15823-39	Screw, #8-18 x 1/2"	2	OPTIONAL ACCESSORIES			
15	NTC-4C	Hex Lock Nut, 1/4-20	2		HA1180	Air Gauge Kit	
16	102756-01	Fan Guard	1		HA2210	Fuel Tank Filter Screen	
17	102482-01	Ignitor Kit	1		HA3005	Rotor Kit (M22456-2, M22009, M8643-2)	
18	M11084-29	Screw, #10-16 x 3/4"	2		HA3017	Filter Kit (M11637, M12179, M12244-1, M51150-01)	
19	M51345-03	Fuel Line	1		HA3020	Pump Kit (M27694, M10993-1, M22997, M8940)	
20	M51150-01**	Fuel Filter	1				
21	M51345-04	Fuel Line Tube	1				
22	M10990-3	Rubber Bushing	1				
23	M50814-03	Airline	1				
24	098511-230	Lower Shell	1				
25	M50104-03	Bushing	2				

** See OPTIONAL ACCESSORIES

*** Not available as an assembly.

200,000 BTU/HR

PORTABLE FORCED AIR HEATER

WHEELS AND HANDLE PARTS LIST

KEY NO.	PART NUMBER	PART DESCRIPTION	QTY.
1	105227-01	Handles	2
2	M12345-33	Screw, #10-24 x 1 3/4"	8
3	M12831-3	Wheel Support Frame	1
4	NTC-3C	Hex Nut, #10-24	8
5	097896-04	Wheel	2
6	M28526	Cap Nut	2
7	M16801-2	Axle	1

SPECIFICATIONS

Output Rating (Btu/Hr.)	200,000
Fuel	Use Only Kerosene or No. 1 Fuel Oil
Fuel Tank Capacity (U.S. Gal.)	13.5
Fuel Consumption (Gal. Per Hr.)	1.4
Pump Pressure (PSI)	6.0
Electric Requirements	120 V/60 Hz
Amperage (Normal Run)	4.5
Hot Air Output (CFM)	600
Motor RPM	3450
Motor HP	1/4
Shipping Weight (Approx. Lbs)	77
Heater Weight without Fuel (Approx. Lbs)	66

MAINTENANCE KITS

Btu/Hr	200,000
Flame-out Control Part No.	HA3003
Spark Plug Part No.	HA3012
Filter Kit Part No.	HA3017
Nozzle Part No.	100735-13
Rotor/Air Pump Kit Part No.	HA3005
Handle Part No.	HA2204
Photocell Part No.	HA3019
Pump Adjustment Part No.	HA3020

TECHNICAL SERVICE

You may have further questions about installation, operation, or troubleshooting.

If so, contact DESA International's Technical Service Department at 1-800-323-5190.

You can also visit DESA International's Technical Services web site at

www.desatech.com.

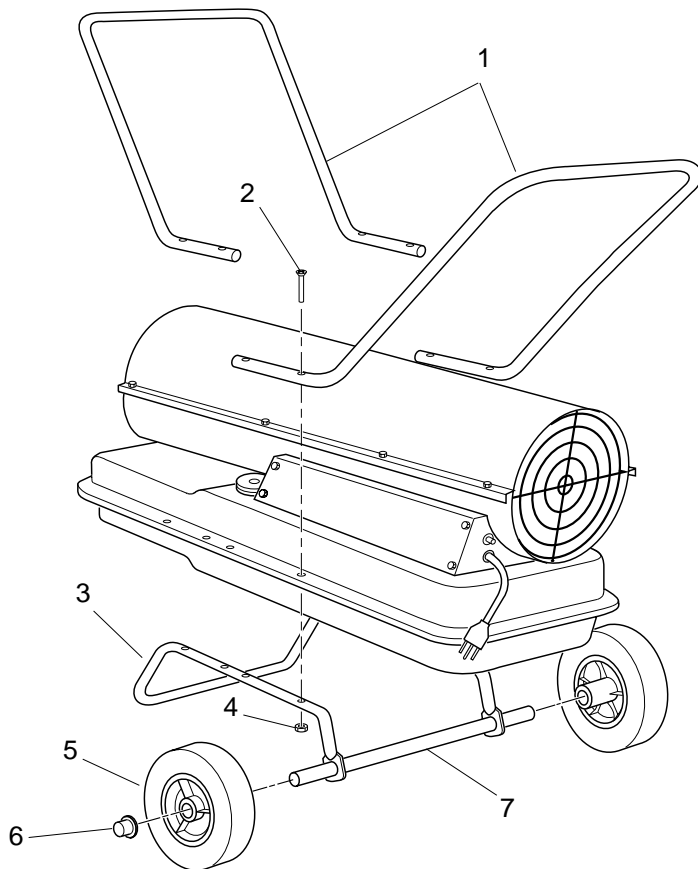

OWNER'S MANUAL

WIRING DIAGRAM

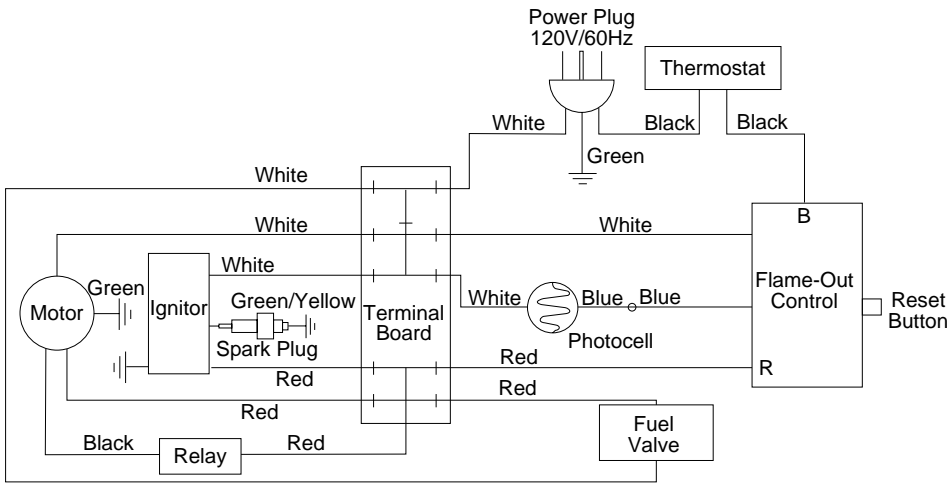

REPLACEMENT PARTS

Note: Use only original replacement parts. This will protect your warranty coverage for parts replaced under warranty.

PARTS UNDER WARRANTY

Contact authorized dealer from whom you purchased this product. If they cannot supply original replacement part(s), call DESA International's Technical Service Department at 1-800-323-5190 for referral information.

When contacting your dealer or DESA International, have ready:

- your name
- your address
- model and serial numbers of your heater
- how heater was malfunctioning
- purchase date

Usually, we will ask you to return the defective part to the factory.

PARTS NOT UNDER WARRANTY

Contact authorized dealers of this product. If they cannot supply original replacement part(s), call DESA International's Parts Department at 1-800-972-7879 for referral information.

When calling DESA International, have ready:

- model number of your heater
- the replacement part number

ACCESSORIES

Purchase accessories and parts from your nearest dealer or service center. If they can not supply these accessories or parts, either contact your nearest Parts Central or DESA International for referral information. Parts Centrals are listed in the Authorized Service Center booklet supplied with heater.

DESA International
P.O. Box 90004
Bowling Green, KY
42102-9004
1-800-972-7879
Parts Department

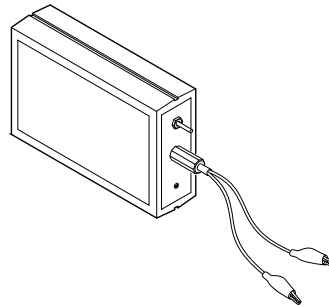

FLAME-OUT CONTROL/ PHOTOCELL TESTER HA1170

Special tool used to test the flame-out control and photocell.

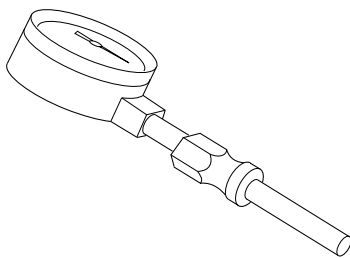

AIR GAUGE KIT - HA1180

Special tool to check pump pressure.

WARRANTY AND REPAIR SERVICE

KEEP THIS WARRANTY

Model No.	_____
Serial No.	_____
Date of Purchase	_____

(To be filled in by purchaser)

LIMITED WARRANTY

DESA International warrants this product and any parts thereof, to be free from defects in materials and workmanship for one (1) year from the date of first purchase when operated and maintained in accordance with instructions. This warranty is extended only to the original retail purchaser, when proof of purchase is provided.

This warranty covers only the cost of parts and labor required to restore the product to proper operating condition. Transportation and incidental costs associated with warranty repairs are not reimbursable under this warranty.

Warranty service is available only through authorized dealers and service centers.

This warranty does not cover defects resulting from misuse, abuse, negligence, accidents, lack of proper maintenance, normal wear, alteration, modification, tampering, contaminated fuels, repair using improper parts, or repair by anyone other than an authorized dealer or service center. Routine maintenance is the responsibility of the owner.

THIS EXPRESS WARRANTY IS GIVEN IN LIEU OF ANY OTHER WARRANTY EITHER EXPRESSED OR IMPLIED, INCLUDING WARRANTIES OF MERCHANTABILITY AND FITNESS FOR A PARTICULAR PURPOSE.

DESA International assumes no responsibility for indirect, incidental or consequential damages. Some states do not allow the exclusion or limitation of incidental or consequential damages or limitations or exclusions may not apply to you. This Limited Warranty gives you specific legal rights and you may also have other rights which vary from state to state.

WARRANTY SERVICE

Should your heater require service, return it to your nearest authorized service center. Proof of purchase must be presented with the heater. The heater will be inspected. A defect may be caused by faulty materials or workmanship. If so, DESA International will repair or replace the heater without charge.

REPAIR SERVICE

Return the heater to your nearest authorized service center. Repairs not covered by the warranty will be billed at standard prices.

Illustrated parts lists can be obtained free of charge. Send a self addressed stamped envelope to the address listed below. List the heater model number and the date located in the lower right corner of this page. A service manual may be purchased from the address listed below. Send a check for \$5.00 payable to DESA International.

When writing for information regarding your heater, be sure to include the model number and serial number as shown on the model plate.

Each Service Center is independently owned and operated.

We reserve the right to amend these specifications at any time without notice.

DESA
INTERNATIONAL
Corporate Headquarters
2701 Industrial Drive
P.O. Box 90004
Bowling Green, KY 42102-9004
www.desatech.com



103607 01

NOT A UPC

For information, write: DESA International, P.O. Box 90004
Bowling Green, Kentucky 42102-9004 ATTN: Customer Service Department
When writing, always include model number and serial number.

103607-01
Rev. H
10/99

Free Manuals Download Website

<http://myh66.com>

<http://usermanuals.us>

<http://www.somanuals.com>

<http://www.4manuals.cc>

<http://www.manual-lib.com>

<http://www.404manual.com>

<http://www.luxmanual.com>

<http://aubethermostatmanual.com>

Golf course search by state

<http://golfingnear.com>

Email search by domain

<http://emailbydomain.com>

Auto manuals search

<http://auto.somanuals.com>

TV manuals search

<http://tv.somanuals.com>