

VANGUARD[®]

VENTED NATURAL GAS HEATERS

OWNER'S OPERATION AND INSTALLATION MANUAL

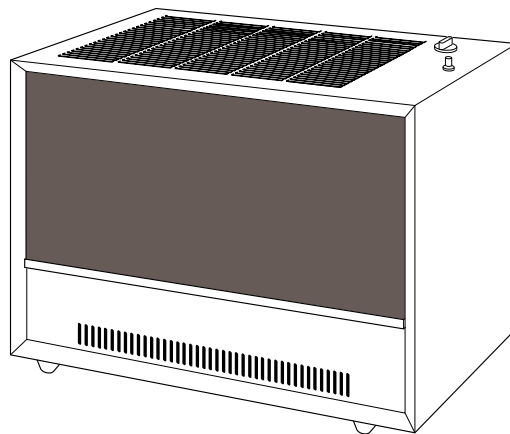

Models: GVC65NA, GVC50NA, GVC35NA

WARNING: If the information in this manual is not followed exactly, a fire or explosion may result causing property damage, personal injury, or loss of life.

FOR YOUR SAFETY

- Do not store or use gasoline or other flammable vapors and liquids in the vicinity of this or any other appliance.
- **WHAT TO DO IF YOU SMELL GAS**
 - Do not try to light any appliance.
 - Do not touch any electrical switch; do not use any phone in your building.
 - Immediately call your gas supplier from a neighbor's phone. Follow the gas supplier's instructions.
 - If you cannot reach your gas supplier, call the fire department.
- Installation and service must be performed by a qualified installer, service agency, or the gas supplier.

WARNING: Improper installation, adjustment, alteration, service, or maintenance can cause property damage, personal injury or loss of life. Refer to this manual for correct installation and operational procedures. For assistance or additional information consult a qualified installer, service agency, or the gas supplier.



Save this manual for future reference.

CONTENTS

| SECTION | PAGE |
|--|------------|
| Safety Information | 3 |
| Product Identification | 5 |
| Local Codes | 6 |
| Unpacking | 6 |
| Product Features | 6 |
| Installing Heater | 6 |
| Check Gas Type | 6 |
| Installation Items | 6 |
| Locating Heater | 7 |
| Venting Heater | 8 |
| Connecting to Gas Supply | 11 |
| Checking Gas Connections | 13 |
| Fresh Air For Combustion and Ventilation | 14 |
| Determining Fresh-Air Flow for Heater Location | |
| Example 1: Locating Heater in Unconfined (Open) Area | 15 |
| Draft Hood Spillage Test | 15 |
| Providing Permanent Fresh-Air Ventilation | 16 |
| Example 2: Locating Heater in Confined (Closed) Area.. | 17 |
| Ventilating Confined Area | 17 |
| Operating Heater | 18 |
| For Your Safety Read Before Lighting | 18 |
| Lighting Instructions | 18 |
| Manual Lighting Procedure | 20 |
| Blower Operation (For Models with Blower) | 20 |
| To Turn Off Gas To Appliance | 20 |
| Inspecting Pilot and Burner Flame | 21 |
| Pilot Flame Pattern | 21 |
| Burner Flame Pattern | 21 |
| Cleaning and Maintenance | 23 |
| Troubleshooting | 24 |
| Service Procedures | 28 |
| Removing Control Valve and Burner Tube | 28 |
| Removing Burner | 29 |
| Changing Burner Orifice | 30 |
| Blower Wiring Diagram | 30 |
| Technical Service | 31 |
| Specifications | 31 |
| Service Hints | 31 |
| Accessories | 31 |
| Ordering Replacement Parts | 32 |
| Parts Centrals | 32 |
| Illustrated Parts List | 33-35 |
| Warranty Information | Back Cover |

SAFETY INFORMATION

WARNINGS

IMPORTANT: Read this owner's manual carefully and completely before trying to assemble, operate, or service this heater. Improper use of this heater can cause serious injury or death from burns, fire, explosion, electrical shock, and carbon monoxide poisoning.

DANGER

Carbon monoxide poisoning may lead to death!

Carbon Monoxide Poisoning: Early signs of carbon monoxide poisoning resemble the flu, with headaches, dizziness, or nausea. If you have these signs, the heater may not be operating or venting properly. **Get fresh air at once!** Have heater or heater venting system serviced. Some people are more affected by carbon monoxide than others. These include pregnant women, people with heart or lung disease or anemia, those under the influence of alcohol, and those at high altitudes.

Natural Gas: Natural gas is odorless. An odor-making agent is added to natural gas. The odor helps you detect a natural gas leak. However, the odor added to natural gas can fade. Natural gas may be present even though no odor exists.

Make certain you read and understand all Warnings. Keep this manual for reference. It is your guide to safe and proper operation of this heater.

1. A qualified service person must install heater and venting system.
2. Use only natural gas. Do not convert heater to use different fuel type.
3. If you smell gas
 - Shut off gas supply.
 - Do not try to light any appliance.
 - Do not touch any electrical switch; do not use any phone in your building.
 - Immediately call your gas supplier from a neighbor's phone. Follow the gas supplier's instructions.
 - If you cannot reach your gas supplier, call the fire department.
4. This heater must have fresh air for proper operation. If not, poor fuel combustion and improper venting of flue gases will result. Carbon monoxide poisoning from backed-up flue gases could occur. The State of California lists carbon monoxide as a reproductive toxin under Proposition 65. Read the instructions under *Fresh Air for Combustion and Ventilation*, pages 14 through 17 for complete information.
5. Never install the heater
 - in a mobile home or a recreational vehicle.
 - where curtains, furniture, clothing, or other flammable objects are less than 48 inches from the front, 53 inches from top, or 12 inches from right side and 6 inches from left side and back of heater.
 - directly on carpeting, tile, or other combustible materials other than wood flooring. Place heater on metal or wood panel extending the full width and depth of heater.
 - as a fireplace insert.
 - in high traffic areas.
 - in windy or drafty areas.

Continued

SAFETY INFORMATION

Continued

WARNINGS *Continued*

6. Provide the following minimum heater clearances from combustibles (as viewed from the front of heater):
 - Front: 48 inches
 - Back: 6 inches
 - Top: 53 inches
 - Right Side: 12 inches
 - Left Side: 6 inches
7. Do not run heater
 - where flammable liquids or vapors are used or stored
 - under dusty conditions
8. Never place clothing or any flammable objects on the heater or venting system.
9. Heater and venting system surfaces are very hot during operation. Keep children and adults away from hot surfaces to avoid burns or clothing ignition. Carefully supervise young children when they are in the same room as heater. Heater will remain hot for a time after shutdown. Let surface cool before touching.
10. Do not use heater as a cooking device.
11. Do not alter heater or its controls. Any change may create a safety hazard.
12. Turn off heater and unplug (if equipped with blower) and let cool before servicing. Unless you need gas supply for testing, shut off manual shutoff valve before servicing. Only a qualified service person should service and repair heater and venting system.
13. Replace any safety screen or guard removed for servicing before running heater.
14. Do not use heater if any part has been under water. Immediately call a qualified service person to inspect the heater and to replace any part of the control system and any gas control which has been under water.

PRODUCT IDENTIFICATION

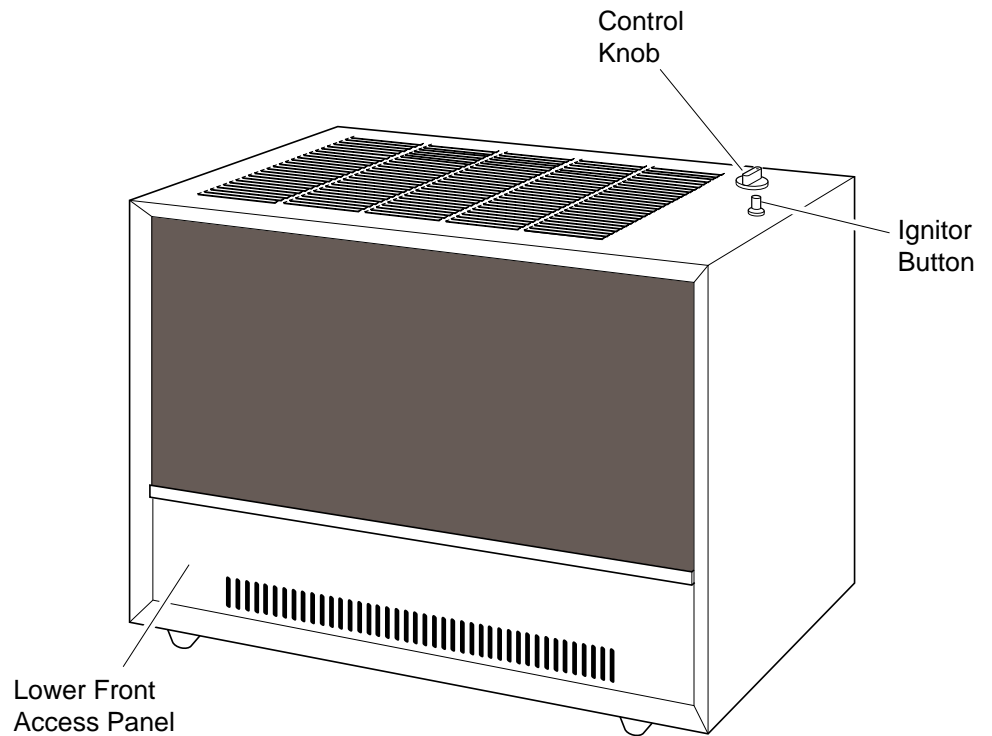

Figure 1 - Vented Natural Gas Heater

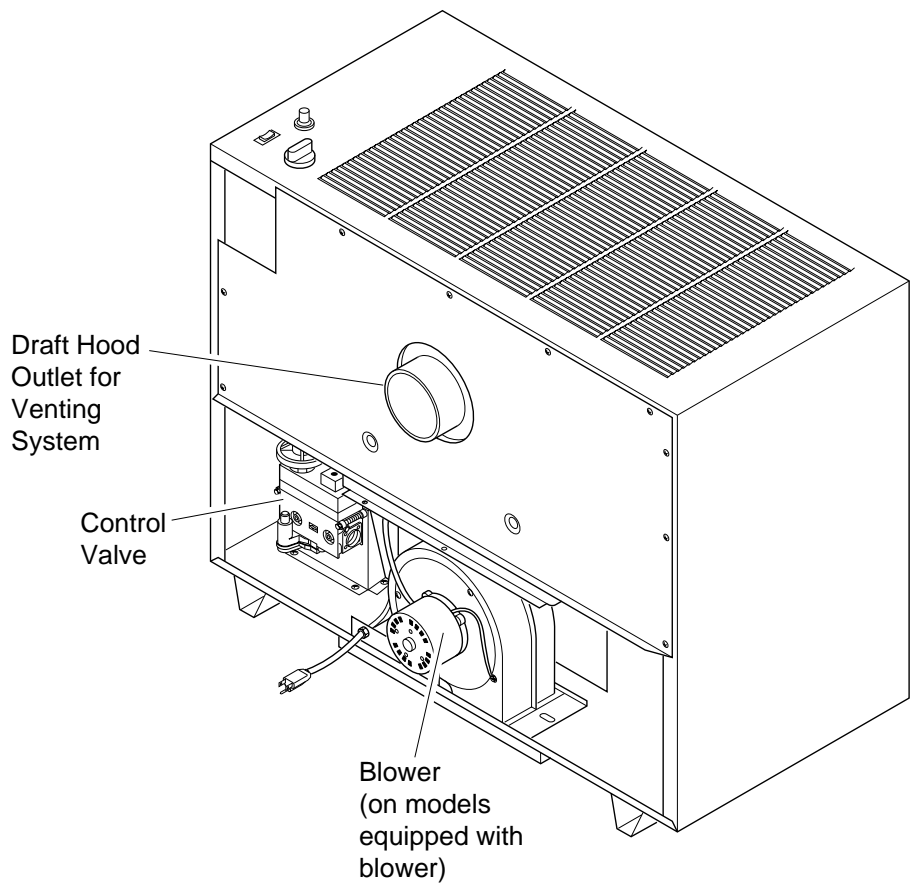

Figure 2 - Vented Natural Gas Heater, Rear View

LOCAL CODES

Install and use heater with care. Follow all local codes. In the absence of local codes, use the latest edition of the following:

- National Fuel Gas Code ANSI Z223.1, also known as NFPA 54 *
- National Electrical Code ANSI/NFPA 70 *
- National Standard of Canada CAN1-B149 **

*Available from: American National Standards Institute, Inc., 1430 Broadway, New York, NY 10018; or National Fire Protection Association, Inc., Batterymarch Park, Quincy, MA 02269

**Available from: Standards Council of Canada, 350 Sparks Street, Ottawa, Ontario, K1R 7S8

UNPACKING

1. Remove heater from carton.
2. Remove all protective packaging applied to heater for shipment.
3. Check heater for any shipping damage. If heater is damaged, promptly inform dealer where you bought heater.

PRODUCT FEATURES

Piezo Ignition System

This heater has a piezo ignitor. This system requires no matches, batteries, or other sources to light heater.

Thermostatic Heat Control

This heater has a thermostat sensing bulb and a control valve. This results in the greatest heating comfort. This can also result in lower gas bills.

INSTALLING HEATER

WARNING

A qualified service person must install heater and venting system. Have them inspect heater before use and at least annually. Follow all local codes.

NOTICE

This heater must be electrically grounded if equipped with blower. Follow all local codes. In the absence of local codes, follow the National Electric Code, ANSI/NFPA 70 (U.S.) or Canadian Electrical Code CSA C22.1 (Canada).

CHECK GAS TYPE

Use only natural gas. If your gas supply is not natural gas, do not install heater. Call dealer where you bought heater for proper type heater.

INSTALLATION ITEMS

Before installing heater, make sure you have all items below.

- piping (check local codes)
- sealant (resistant to propane gas)
- manual shutoff valve *
- ground joint union
- test gauge connection * (see Figure 7, page 12)
- sediment trap
- tee joint
- pipe wrench
- venting materials

* An A.G.A. design-certified manual shutoff valve with 1/8" NPT tap is an acceptable alternative to test gauge connection. Purchase the optional A.G.A. design-certified manual shutoff valve from your dealer. See *Accessories*, page 31.

INSTALLING HEATER

Continued

LOCATING HEATER

⚠ WARNING

Maintain the minimum clearances shown in Figure 3, below. If you can, provide greater clearances.

⚠ WARNING

Never install the heater

- in a mobile home or a recreational vehicle.
- where curtains, furniture, clothing, or other flammable objects are less than 48 inches from the front, 53 inches from the top, 12 inches from the right side and 6 inches from the left side and back of heater.
- directly on carpeting, tile, or other combustible materials other than wood flooring. Place heater on metal or wood panel extending the full width and depth of heater.
- as a fireplace insert.
- in high traffic areas.
- in windy or drafty areas.

⚠ CAUTION

If you install the heater in a home garage

- heater pilot and burner must be at least 18 inches above floor
- locate heater where moving vehicle will not hit it.

For convenience and efficiency, install heater

- where there is easy access for operation, inspection, and service.
- in coldest part of room.
- near an electrical outlet if heater has blower or if you are planning to add blower to heater. See *Accessories*, page 31 for blower.

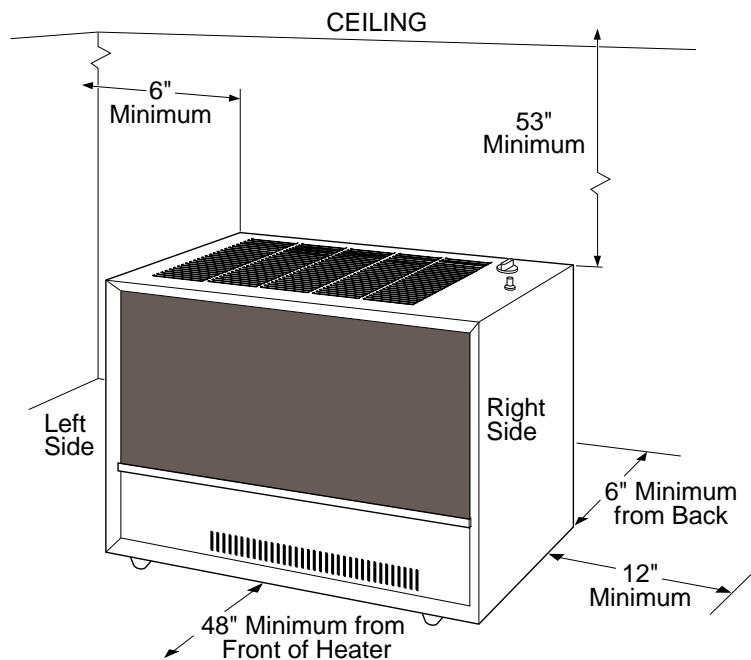

Figure 3 - Heater Clearances

Continued

INSTALLING HEATER

Continued

VENTING HEATER

Note: Venting/chimney materials are not supplied with heater.

WARNING

A qualified service person must install the venting system for this heater. If venting system is not properly installed and maintained, the vent safety shut-off system will prevent the heater from running. Follow all local codes.

WARNING

This heater has a vent safety shut-off system. This system shuts off the heater gas supply if you do not vent heater properly or the venting system is blocked. Do not operate heater if not properly vented. Do not tamper with the vent safety shut-off system. Carbon monoxide poisoning and death may result.

WARNING

When venting this heater, follow the safety information listed below.

- Never vent heater to another room or inside a building. Only vent heater to the outdoors.
- Do not vent heater exhaust to a chimney or flue serving another solid-fuel-burning or gas appliance.
- We recommend you use flues classified as prefabricated or masonry all-fuel chimney or type-B vent. See *Vent Types*, page 10.
- If using old vent, check vent for soot, creosote, and loose particles. If vent is damaged, repair or replace it before using heater.
- Extend the vertical section of vent pipe at least three feet above roof penetration.
- Extend the vertical section of vent pipe at least two feet above the highest point of any roof within ten feet.
- The horizontal run of vent pipe should rise at least 1/4 inch for each foot of run.
- Support the vent pipe at least every five feet along its length. Do not use combustible materials to support vent pipe.
- Never extend vent pipe horizontally through outside wall and terminate. You must connect a vertical run of vent pipe to the horizontal run. The vertical run must be at least 25% longer than the horizontal run.
- Install vent or chimney cap that is approved for use with vented gas room heaters.
- Do not use vent pipe smaller in diameter than that of the heater draft hood outlet.
- Do not use dampers in the vent pipes.
- Vertical height of vent must be greater than five feet above vent connection at draft hood.

INSTALLING HEATER

Continued

VENTING HEATER *(continued)*

WARNING

Do not vent heater in any of the following ways (see Figure 4).

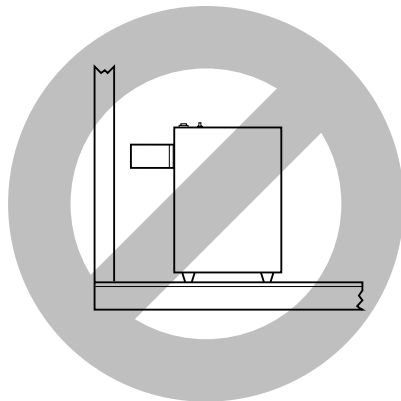

Heater must be vented to the outdoors. Never vent heater to another room or inside a building.

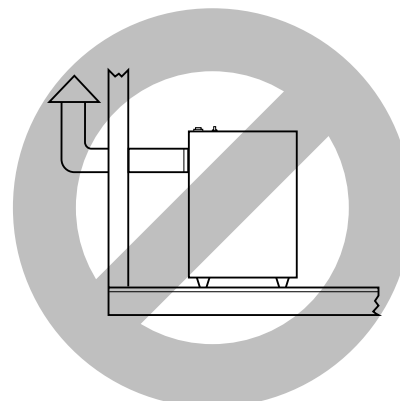

The vertical section of vent pipe must extend at least two feet above the highest point of any roof within ten feet.

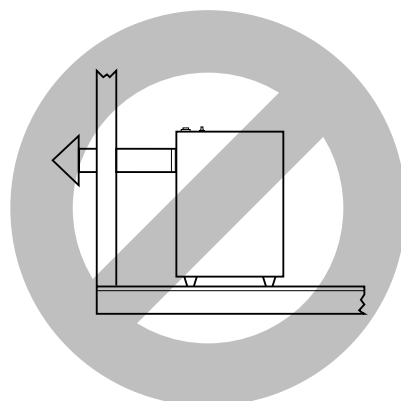

Never extend vent pipe horizontally through outside wall and terminate. You must connect a vertical run of vent pipe to the horizontal run. The vertical run must be at least 25% longer than the horizontal run.

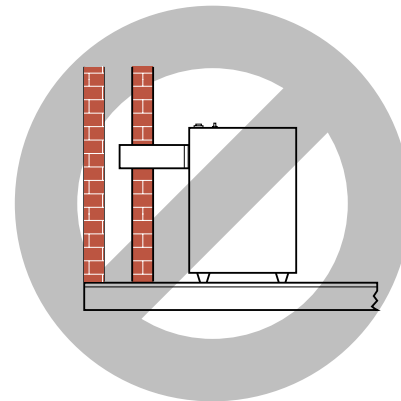

Never extend vent pipe horizontally through a chimney or flue. You must connect a vertical run of vent pipe to the horizontal run. The vertical run must be at least 25% longer or five feet minimum than the horizontal run.

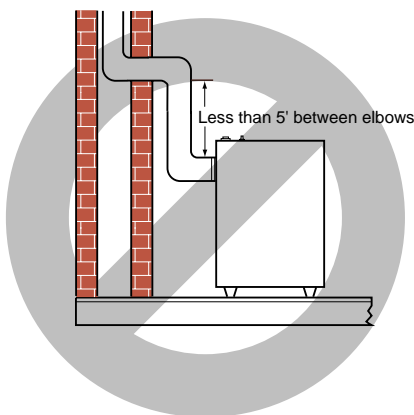

Vertical run of pipe must be at least five feet from elbow to elbow.

Figure 4 - Improper Venting Systems

Continued

INSTALLING HEATER

Continued

VENTING HEATER *(continued)*

Proper Size Vent

To safely vent heater, the vent connector pipe must be the same diameter as the draft hood outlet on the rear of the heater. Pipe that is too small can cause flue gas to spill from the heater. Fasten vent connector to the draft hood outlet with a sheet metal screw.

Vent Types

Prefabricated or Masonry All-Fuel Chimney - This is a masonry chimney or a residential-type prefabricated chimney. Only use prefabricated chimneys listed by Underwriters Laboratories (UL), Inc.

Type-B Vent - These vents are made of noncombustible, corrosion resistant material. They are certified by a nationally recognized testing agency. Type-B vents are double-walled pipe. Clearances to combustible construction must be in accordance with the listing of the particular type-B vent. Type-B vents are currently listed as B-1, B-1 1/2, and B-2.

The illustrations below show both vent types. The illustration shows typical construction of each type of venting system. Minimum clearances and lengths are added to the illustrations.

Terminate at least 5' above draft hood. If vent extends over 5' above roof, support with guy wires or braces.

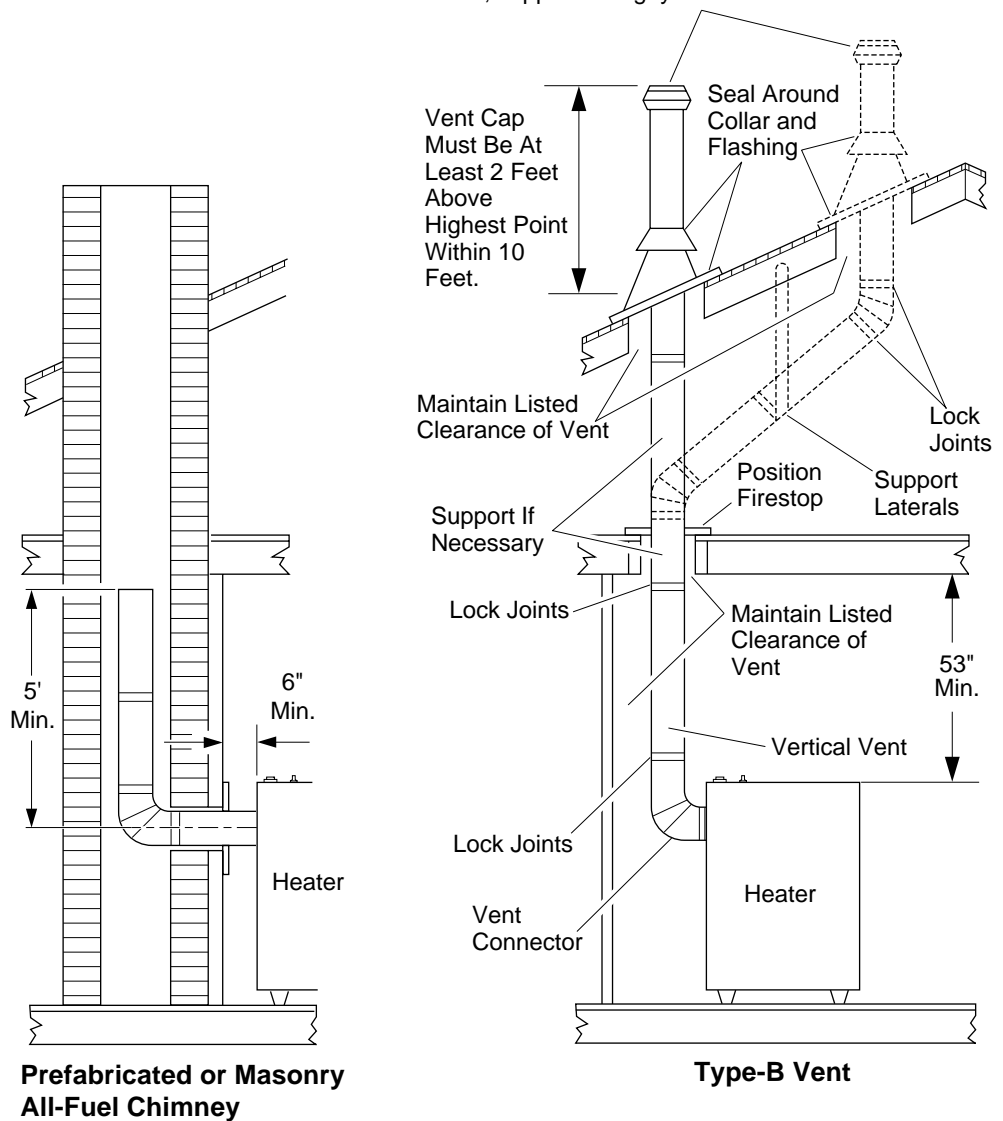

Figure 5 - Typical Construction of Venting Systems

INSTALLING HEATER

Continued

CONNECTING TO GAS SUPPLY

⚠ WARNING

A qualified service person must connect heater to gas supply. Follow all local codes.

⚠ WARNING

Never connect heater to private (non-utility) gas wells. This gas is commonly known as well-head gas.

IMPORTANT: Check gas line pressure at gas meter before connecting heater to gas line. Gas line pressure must be no greater than 14 inches of water. If gas line pressure is higher, heater regulator damage could occur.

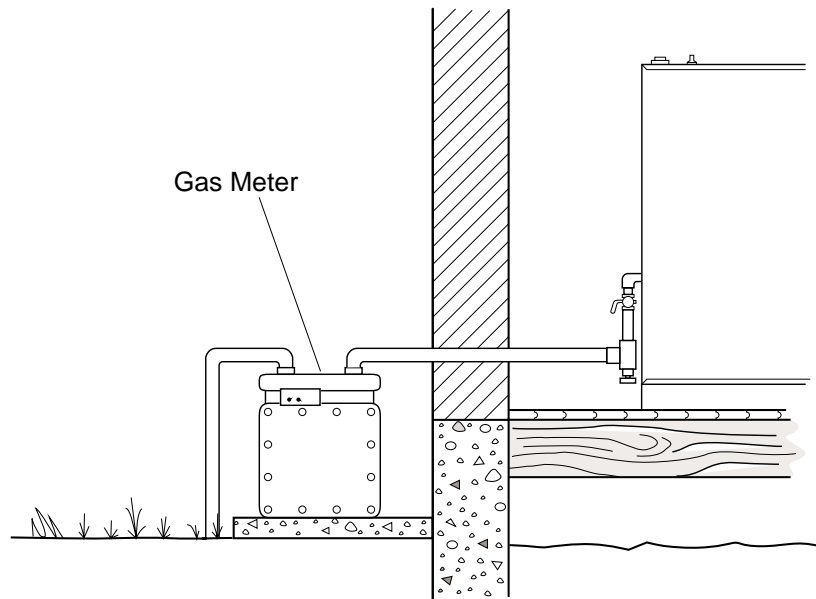

Figure 6 - Connecting Heater to Utility Gas Line

⚠ CAUTION

Use only new, black iron or steel pipe. Internally-tinned copper tubing may be used in certain areas. Check your local codes. Use pipe that is 1/2" in diameter or greater to allow proper gas volume to heater. If pipe is too small, undue loss of pressure will occur.

The gas supply line to your heater must be 1/2 inch in diameter or larger. If the supply line branches to serve two or more heaters, the line from the branch back to the gas meter must be doubled or tripled, etc., in size (depending upon the number of heaters). *Example for 1/2 inch diameter supply line:* If the supply line branches to serve two heaters, the line diameter from the branch back to the gas meter must be at least 1 inch. If three heaters are served, the line diameter from the branch back to the gas meter must be at least 1 1/2 inches.

Note: If gas supply line total length exceeds forty feet, use a larger diameter pipe. Use pipe that is the next size larger than the heater control valve fitting.

Continued

INSTALLING HEATER

Continued

Installation must include a manual shutoff valve, ground joint union, plugged 1/8" NPT tap, and a sediment trap. Locate NPT tap within reach for test gauge hook up. NPT tap must be upstream from heater (see Figure 7).

Apply pipe joint sealant lightly to male threads. This will prevent excess sealant from going into pipe. Excess sealant in pipe could result in clogged heater valves.

⚠ CAUTION

Use pipe joint sealant that is resistant to liquid petroleum (LP) gas.

Install sediment trap in supply line as shown in Figure 7. Locate sediment trap where it is within reach for cleaning. Locate sediment trap where trapped matter is not likely to freeze. A sediment trap traps moisture and contaminants. This keeps them from going into heater controls. If sediment trap is not installed or is installed wrong, heater may not run properly.

IMPORTANT: Use two pipe wrenches when connecting gas piping to gas control valve of heater. This will prevent turning or damaging control valve.

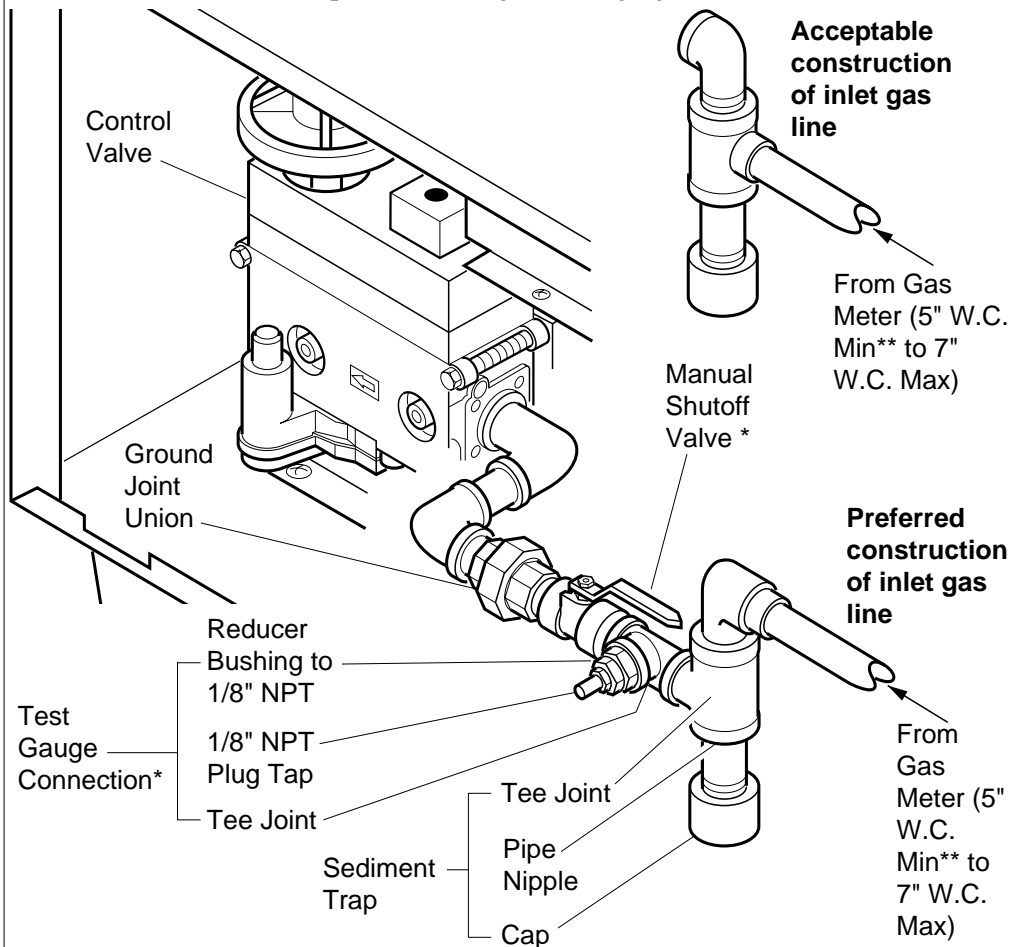

Figure 7 - Gas Connection

* An A.G.A. design-certified manual shutoff valve with 1/8" NPT tap is an acceptable alternative to test gauge connection. Purchase the optional A.G.A. design-certified manual shutoff valve from your dealer. See *Accessories*, page 31.

** For purposes of input adjustment.

INSTALLING HEATER

Continued

CHECKING GAS CONNECTIONS

⚠ WARNING

Test all gas piping and connections for leaks after installing or servicing. Correct all leaks at once.

⚠ WARNING

Never use an open flame to check for a leak. Apply a mixture of liquid soap and water to all joints. Bubbles forming show a leak. Correct all leaks at once.

Pressure Testing Gas Supply Piping System

Test Pressures In Excess of 1/2 PSIG

1. Disconnect heater and its individual manual shutoff valve from gas supply pipe. Pressures in excess of 1/2 PSIG will damage heater regulator.
2. Cap off open end of gas pipe where manual shutoff valve was connected.
3. Pressurize supply piping system by either using compressed air or opening main gas valve located on or near gas meter.
4. Check all joints of gas supply piping system. Apply mixture of liquid soap and water to gas joints. Bubbles forming show a leak.
5. Correct all leaks at once.

Test Pressures Equal To or Less Than 1/2 PSIG

1. Close manual shutoff valve (see Figure 8).
2. Pressurize supply piping system by either using compressed air or opening main gas valve located on or near gas meter.
3. Check all joints from propane supply tank to manual shutoff valve. Apply mixture of liquid soap and water to gas joints. Bubbles forming show a leak.
4. Correct all leaks at once.

Pressure Testing Heater Gas Connections

1. Open manual shutoff valve (see Figure 8).
2. Open main gas valve located on or near gas meter.
3. Make sure control knob of heater is in the OFF position.
4. Check all joints from manual shutoff valve to control valve on heater. Apply mixture of liquid soap and water to gas joints. Bubbles forming show a leak.
5. Correct all leaks at once.
6. Light heater (see *Operating Heater*, pages 18 through 20). Check the rest of the internal joints for leaks.
7. Turn off heater (see *To Turn Off Gas to Appliance*, page 20).

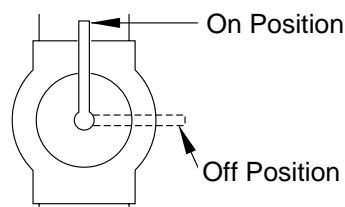

Figure 8 - Manual Shutoff Valve

FRESH AIR FOR COMBUSTION AND VENTILATION

WARNING

This heater must have fresh air for proper operation. If not, poor fuel combustion and improper venting of flue gases will result. Carbon monoxide poisoning from backed-up flue gases could occur. Read the following instructions to insure proper fresh air for this and other fuel-burning appliances in your home.

Today's homes are built more energy efficient than ever. New materials, increased insulation, and new construction methods help reduce heat loss in homes. Home owners weather strip and caulk around windows and doors to keep the cold air out and the warm air in. During heating months, home owners want their homes as airtight as possible.

While it is good to make your home energy efficient, it is not good to make it too airtight. Your home needs to breath. If your home is too airtight, fresh air has little chance of entering in. This could be dangerous if you have fuel-burning appliances. These appliances need fresh, outside air for proper combustion and ventilation.

Exhaust fans, fireplaces, clothes dryers, and fuel-burning appliances draw air from the house to operate. This heater is a fuel-burning appliance. It uses air from inside the house for combustion. It also uses this air as a draft for venting. This draft air helps move combustion gases through the vent pipe to the outdoors. If your house is too airtight, there is not enough fresh air for these items to use. Fresh air may draw back into the house through venting flues and chimneys. This will keep fuel-burning appliances from venting properly. This may cause them to release poisonous carbon monoxide gas into your home. It is very important to provide enough fresh air to run all fuel-burning appliances.

DANGER

Carbon monoxide poisoning may lead to death!

Carbon monoxide is a colorless, odorless gas. Early signs of carbon monoxide poisoning resemble the flu, with headaches, dizziness, and/or nausea. If you have these signs, the heater may not be operating or venting properly. **Get fresh air at once!** Have heater or heater venting system serviced. Some people are more affected by carbon monoxide than others. These include pregnant women, persons with heart and lung disease and anemia, those under the influence of alcohol, and those at high altitudes.

FRESH AIR FOR COMBUSTION AND VENTILATION

Continued

DETERMINING FRESH-AIR FLOW FOR HEATER LOCATION

Example 1: Locating Heater in Unconfined (Open) Area

NOTICE

An unconfined area has a minimum air volume of 50 cubic feet for each 1000 BTU/Hr input rating of all appliances in the area (cubic feet equals length x width x height of area). Include adjoining rooms only if there are no doors between the rooms or if you add ventilation grills between the rooms (see *Ventilating Confined Area*, page 17).

In an open area, the air that leaks around doors and windows may provide enough fresh air for combustion and ventilation.

Draft Hood Spillage Test

Follow the steps below to see if enough fresh air is available.

1. Close all windows and doors.
2. If you have a fireplace, start a fire. Build fire until flames are burning strongly.
3. Turn on all exhaust fans. These include exhaust fans for kitchen, bathroom, water heaters (gas or electric), etc.
4. Turn on all vented gas appliances. These include any room heaters, water heaters, clothes dryer, etc.
5. Wait ten minutes for drafts to regulate.
6. Check for draft-hood spillage at each vented gas appliance. Do this by holding a lit match two inches from the draft opening (see Figure 9). If match flame pulls toward the draft hood, there is no spillage. If match flame blows away from the draft hood, there is spillage. This is a hazardous condition. See *Draft Hood Spillage*, page 16.

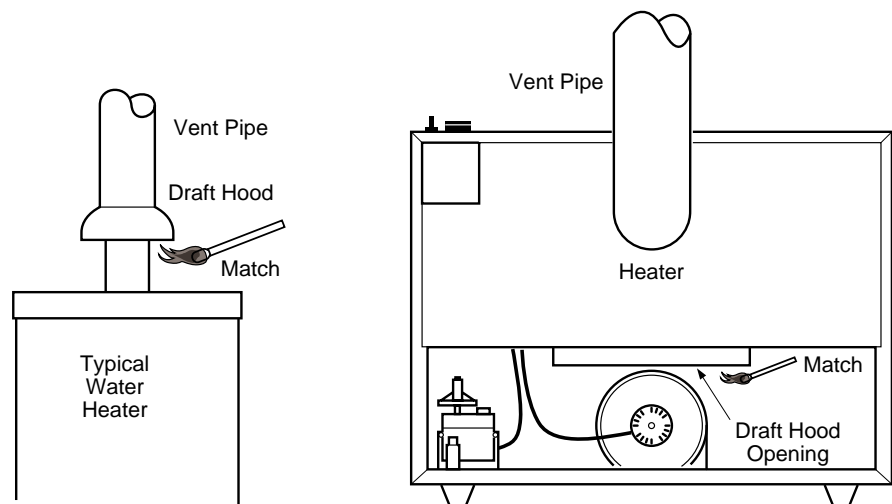

Figure 9 - Checking for Draft Spillage

No Draft Hood Spillage: This shows there is enough fresh air in area for appliances. Turn off all exhaust fans and appliances if desired.

Continued

FRESH AIR FOR COMBUSTION AND VENTILATION

Continued

Draft Hood Spillage: This is a hazardous situation. Draft hood spillage releases poisonous carbon monoxide gas into your home.

! DANGER

Carbon monoxide poisoning may lead to death!

If draft hood spillage occurs, check for blocked flue connectors, vent pipes, and chimneys. If you find blockage, remove. Test again for spillage. If spillage still occurs or there was no blockage, you need more fresh, outside air in the house. You must provide additional fresh-air ventilation. Follow the steps below at once.

- A. Open a window near the appliance(s) at least two inches. Test again for spillage. If spillage does not stop, open window more and retest. If spillage stops, keep window open while running appliance(s). Supply fresh, outside air by a permanent method as soon as possible. If spillage still occurs, leave window open and go to next step.
- B. If you have a fireplace, open a window or door near it at least two inches. Test again for spillage. If spillage does not stop, open window or door more and retest. If spillage stops, keep window or door open while using fireplace. Supply fresh, outside air by a permanent method as soon as possible. If spillage still occurs, leave window or door open and go to next step.
- C. If you have kitchen and bathroom exhaust fans, turn them off. Test again for spillage. If spillage stops, do not use exhaust fans. Turn off circuit breakers for fans if possible. Permanently supply fresh, outside air as soon as possible.

Providing Permanent Fresh-Air Ventilation

If draft hood spillage occurs, you must permanently supply fresh, outside air to the inside of your house. Provide extra fresh air by using ventilation grills or ducts. Connect these items directly to the outdoors or spaces open to the outdoors. These spaces include attics and crawl spaces. If you install this heater in an area with other gas appliances, you must total the BTU/Hr input rating of all appliances. Follow the National Fuel Gas Code NFPA 54/ANSI Z223.1. It lists fresh-air requirements for fuel-burning appliances.

IMPORTANT

Do not provide openings for inlet or outlet air into attic if attic has a thermostat controlled power vent.

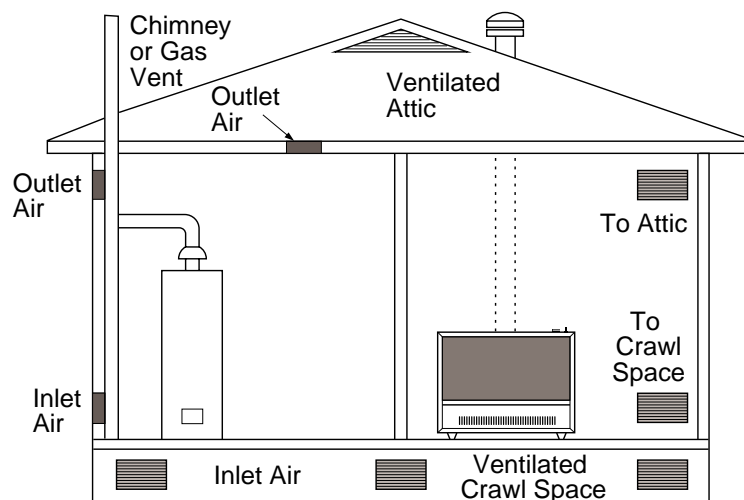

Figure 10 - Ventilation Air from Outdoors

FRESH AIR FOR COMBUSTION AND VENTILATION

Continued

Example 2: Locating Heater in Confined (Closed) Area

NOTICE

A confined area has an air volume of less than 50 cubic feet for each 1000 BTU/Hr input rating of all appliances in the area (cubic feet equals length x width x height of area). Include adjoining rooms only if there are no doors between the rooms.

If you install this heater in a confined area, you must provide additional fresh air.

Ventilating Confined Area

This fresh air would come from an adjoining open area or outdoors.

WARNING

The adjoining open area must have enough fresh, outside air ventilation to supply any appliance in that area plus the confined area. Follow instructions under *Example 1: Locating Heater in Unconfined (Open) Area*, page 15 to make sure fresh air ventilation is adequate.

When ventilating to an adjoining open area, you must provide two permanent openings: one within 12" of the ceiling and one within 12" of the floor on the wall connecting the two areas. Follow the National Fuel Gas Code NFPA 54/ANSI Z223.1. It lists fresh-air requirements for fuel-burning appliances.

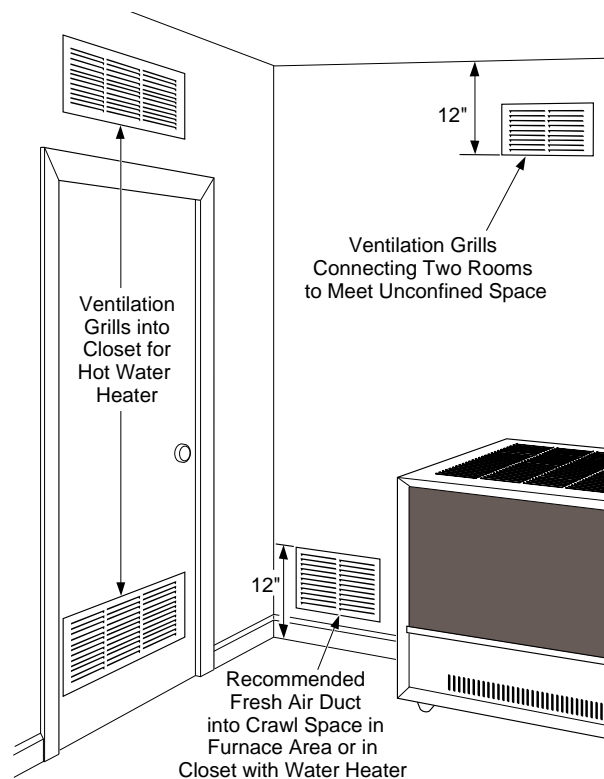

Figure 11 - Ventilation Air from Inside Building

After providing ventilation between rooms, check for draft hood spillage (see *Draft Hood Spillage Test*, page 15). If draft hood spillage still occurs, provide more ventilation between rooms or provide permanent ventilation from outdoors. See *Providing Permanent Fresh-Air Ventilation*, page 16.

OPERATING HEATER

⚠ WARNING

Heater and venting system surfaces are very hot during operation. Keep children and adults away from hot surfaces to avoid burns and clothing ignition. Carefully supervise young children when they are in the same room as heater. Heater will remain hot for a time after shut down. Let surface cool before touching.

NOTICE

If operating heater for the first time, a slight odor will occur. This odor will go away after a few hours of operation.

FOR YOUR SAFETY READ BEFORE LIGHTING

⚠ WARNING

If you do not follow these instructions exactly, a fire or explosion may result causing property damage, personal injury or loss of life.

- A. This appliance has a pilot which must be lighted by hand. When lighting the pilot, follow these instructions exactly.
- B. **BEFORE LIGHTING** smell all around the appliance area for gas. Be sure to smell next to the floor because some gas is heavier than air and will settle on the floor.

WHAT TO DO IF YOU SMELL GAS

- Do not try to light any appliance.
 - Do not touch any electric switch; do not use any phone in your building.
 - Immediately call your gas supplier from a neighbor's phone. Follow the gas supplier's instructions.
 - If you cannot reach your gas supplier, call the fire department.
- C. Use only your hand to push in or turn the gas control knob. Never use tools. If the knob will not push in or turn by hand, don't try to repair it, call a qualified service technician or gas supplier. Force or attempted repair may result in a fire or explosion.
 - D. Do not use this appliance if any part has been under water. Immediately call a qualified service technician to inspect the appliance and to replace any part of the control system and any gas control which has been under water.

LIGHTING INSTRUCTIONS

1. **STOP!** Read the safety information above.
2. If heater is equipped with a blower, turn off all electric power to the heater.
3. Make sure manual shutoff valve is fully open.
4. Locate control knob on top of heater. Fully depress control knob in any position other than PILOT to shut off burner and pilot.

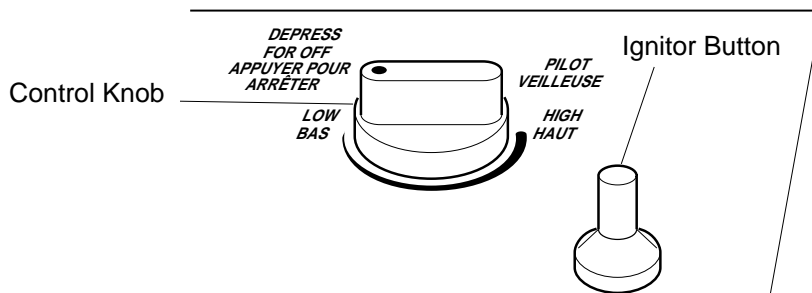



Figure 12 - Control Knob and Ignitor Button

OPERATING HEATER

Continued

5. Wait five (5) minutes to clear out any gas. Then smell for gas, including near the floor. If you smell gas, STOP! Follow “B” in the safety information at the top of page 18. If you don’t smell gas, go to the next step.
6. Remove lower front access panel on heater.
7. Turn control knob clockwise  to the PILOT position. Fully depress control knob for five seconds.
Note: You may be running this heater for the first time after hooking up to gas supply. If so, you may need to depress control knob in for 15 seconds or more. This allows air to bleed from the gas system.
8. With control knob depressed, push down and release ignitor button. This will light pilot. The pilot is attached to the front of burner. You can see pilot with front access panel of heater removed (see Figure 13). If needed, keep pressing ignitor button until pilot lights.
Note: If pilot does not stay lit, refer to *Troubleshooting* pages 24 through 27. Also contact a qualified service person or gas supplier for repairs. Until repairs are made, light pilot with match. To light pilot with match, see *Manual Lighting Procedure*, page 20
9. Keep control knob depressed for 30 seconds after lighting pilot. After 30 seconds, release control knob.
 - If control knob does not pop up when released, contact a qualified service person or gas supplier for repairs.**Note:** If pilot goes out, repeat steps 4 through 9.
10. Replace lower front access panel on heater.
11. If heater is equipped with a blower, turn on all electrical power to the heater.
12. Turn control knob counterclockwise  to desired setting.
13. If equipped, turn blower control to the AUTO or ON position (if desired).

CAUTION

Do not try to adjust heating levels by using the manual shutoff valve.

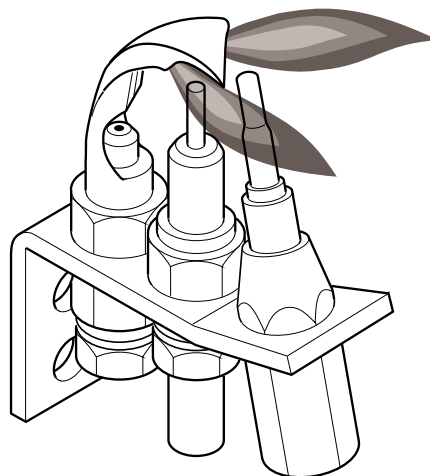

Figure 13 - Viewing Pilot

Continued

OPERATING HEATER

Continued

MANUAL LIGHTING PROCEDURE

1. Remove lower front access panel on heater.
2. Locate pilot. Pilot is attached to the front of burner.
3. Follow steps 1 through 7 under *Lighting Instructions*, pages 18 and 19.
4. With control knob depressed, strike match. Hold match to pilot until pilot lights.
5. Follow steps 9 through 13 under *Lighting Instructions*, page 19.

BLOWER OPERATION (For Models with Blower)

WARNING

This heater has a three-prong, grounded electrical plug. This plug helps protect you against electrical shock. Only connect plug to a properly grounded, three-prong receptacle. Do not cut or remove the grounding prong from this plug.

1. Plug power cord into a standard 115 volt, 60 hertz outlet.
2. Turn the blower control to either the AUTO or ON position. In the AUTO position, as the heater begins to heat, the blower will automatically come on. The blower will remain on until the burner shuts off and cools down. In the ON position, the blower will stay on constantly. Turn the blower control to the OFF position to stop the blower at any time.

TO TURN OFF GAS TO APPLIANCE

Shutting Off Heater

1. Fully depress control knob in any position other than PILOT to shut off burner and pilot.
2. If equipped, turn blower control to OFF position.

Shutting Off Burner Only (pilot stays lit)

1. Turn control knob to the PILOT position. At this setting, only the pilot remains lit.

INSPECTING PILOT AND BURNER FLAME

Check pilot flame pattern and burner flame pattern often.

PILOT FLAME PATTERN

Figure 14 shows a correct pilot flame pattern. Figure 15 shows an incorrect pilot flame pattern. The incorrect pilot flame is not touching the thermocouple. This will prevent the thermocouple from getting hot, causing the heater to shut down.

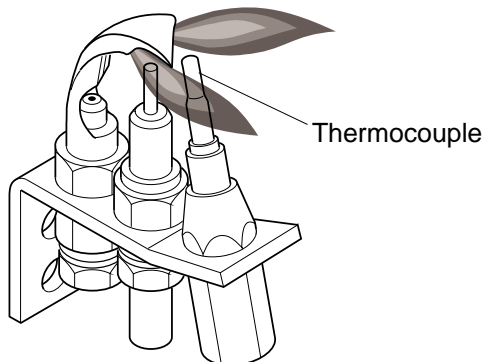

**Figure 14 - Correct Pilot
Flame Pattern**

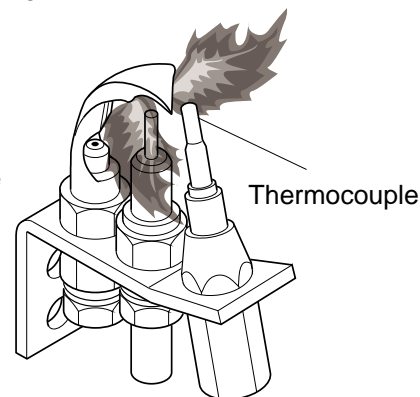

**Figure 15 - Incorrect
Pilot Flame Pattern**

If pilot flame pattern is incorrect, as shown in Figure 15

- turn heater off (see *To Turn Off Gas to Appliance*, page 20)
- contact a qualified service person

BURNER FLAME PATTERN

Note: To view burner flame, remove lower front access panel of heater. View burner flame through oval viewing hole on combustion chamber.

Figure 16, page 22, shows a correct burner flame pattern. Figure 17, page 22, shows two incorrect burner flame patterns. The two incorrect flame patterns show high yellow flames and flames lifting off of burner.

WARNING

If high yellow flame occurs, your heater could produce increased levels of carbon monoxide. If burner flame is incorrect, follow instructions on page 22.

NOTICE

Do not mistake orange flames with yellow flame. Dirt or other fine dust particles enter the heater and burn causing brief patches of orange flame.

Continued

INSPECTING PILOT AND BURNER FLAME

Continued

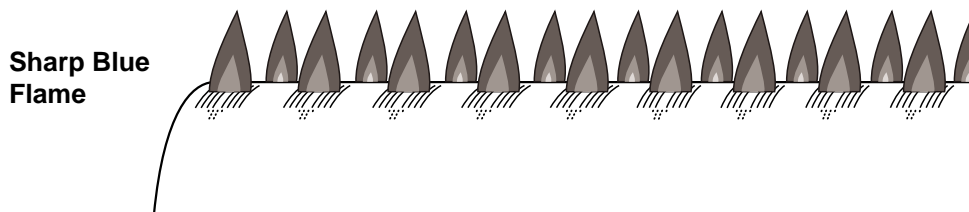

Sharp Blue
Flame

Figure 16 - Correct Burner Flame Pattern

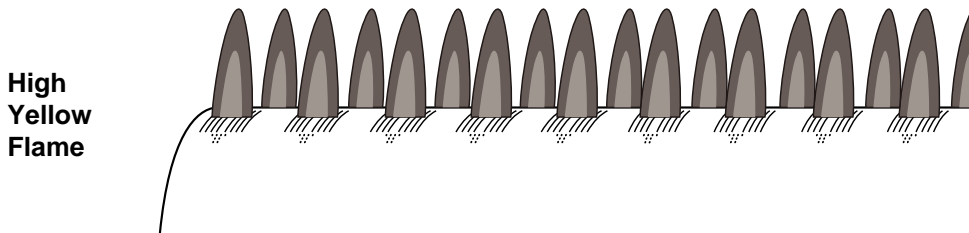

High
Yellow
Flame

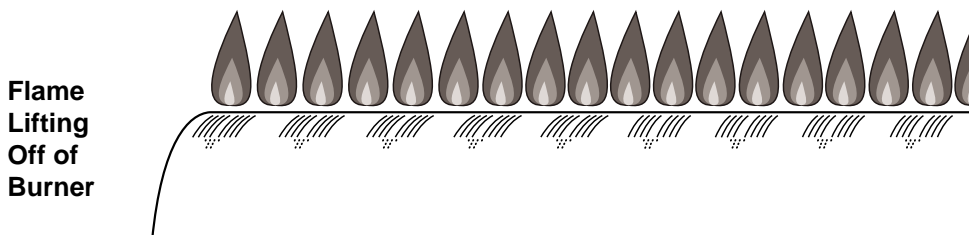

Flame
Lifting
Off of
Burner

Figure 17 - Incorrect Burner Flame Patterns

If burner flame pattern is incorrect, as shown in Figure 17.

- turn heater off (see *To Turn Off Gas to Appliance*, page 20)
- see *Troubleshooting*, pages 24 through 27.

CLEANING AND MAINTENANCE

WARNING

Turn off heater and let cool before cleaning or servicing.

WARNING

Keep heater clear and free from combustible materials, gasoline, and other flammable vapors and liquids.

CAUTION

You must keep control areas, burner, and circulating air passageways of heater clean. Inspect these areas of heater before each use. Have heater and venting system inspected yearly by a qualified service person. Heater may need more frequent cleaning due to excessive lint from carpeting, bedding material, etc.

CABINET

Air Passageways

- Use a vacuum cleaner or pressurized air to clean.

Exterior

- Use a soft cloth dampened with a mild soap and water mixture. Wipe the cabinet to remove dust.

COMBUSTION CHAMBER AND BURNER

Clean the combustion chamber and burner if you have run the heater with a high yellow flame. Incomplete combustion from lack of air causes the yellow flame. This will deposit soot inside the combustion chamber and on the burner. To clean combustion chamber and burner, you must remove the burner from heater. See *Service Procedures*, page 28, to remove burner. After removing burner, blow inside of combustion chamber clean with compressed air. Clean burner with a steel-wire brush. Blow soot from burner with compressed air.

PILOT

Use a vacuum cleaner, compressed air, or small, soft-bristled brush to clean.

BURNER ORIFICE

Use a vacuum cleaner, compressed air, or small, soft-bristled brush to clean. You can also use a tooth pick to clean orifice. Do not enlarge or damage orifice hole.

PILOT AND BURNER FLAME

Check the pilot and burner flame monthly. Make sure pilot and burner flame is burning correctly. See *Inspecting Pilot and Burner Flame*, page 21.

VENTING SYSTEM

Check the venting system at least once a year. Make sure joints are secure and vent pipe is in good condition. Do not obstruct combustion and ventilation air entering the rear of heater.

BLOWER MOTOR (For Models with Blower)

The motor on a new blower is properly lubricated at the factory. The first heating season, the motor will need no additional care. At the beginning of each season afterwards, place a few drops of SAE 20 motor oil in the lubrication holes of motor. Locate the lubrication holes at front and rear of motor on motor casing.

TROUBLE-SHOOTING

Note: All troubleshooting items are listed in order of operation.

WARNING

Turn off and unplug heater and let cool before servicing. Unless you need gas supply for testing, shut off manual shutoff valve before servicing. Only a qualified service person should service and repair heater and venting system.

CAUTION

Never use a wire, needle, or similar object to clean pilot. This can damage pilot.

| OBSERVED PROBLEM | POSSIBLE CAUSE | REMEDY |
|--|---|---|
| When ignitor button is pressed, there is no spark at pilot. | <ol style="list-style-type: none"> 1. Incorrect spark gap. 2. Ignitor electrode positioned wrong. 3. Ignitor electrode broken. 4. Ignitor electrode not connected to ignitor cable. 5. Ignitor cable pinched or wet. 6. Piezo ignitor nut is loose. 7. Broken or frayed ignitor cable. 8. Loose ignitor cable. 9. Bad piezo ignitor. | <ol style="list-style-type: none"> 1. Adjust spark gap to 1/16". 2. Replace ignitor. 3. Replace ignitor. 4. Reconnect ignitor cable. 5. Free ignitor cable if pinched by any metal or tubing. Keep ignitor cable dry. 6. Tighten nut holding piezo ignitor to heater cabinet. Nut is located inside heater cabinet at top. 7. Replace ignitor cable. 8. Reconnect ignitor cable. 9. Replace piezo ignitor. |
| When ignitor button is pressed, there is spark at pilot but no ignition. | <ol style="list-style-type: none"> 1. Gas supply turned off or manual shutoff valve closed. 2. Control knob not in PILOT position. 3. Control knob not pressed in while in PILOT position. 4. Air in gas lines when installed. 5. Pilot is clogged. 6. Gas regulator setting is not correct. | <ol style="list-style-type: none"> 1. Turn on gas supply or open manual shutoff valve. 2. Turn control knob to PILOT position. 3. Press in control knob while in PILOT position. 4. Continue holding down control knob. Repeat igniting operation until air is removed. 5. Clean pilot (see <i>Cleaning and Maintenance</i>, page 23) or replace pilot assembly. 6. Replace control valve. |

TROUBLE-SHOOTING

Continued

| OBSERVED PROBLEM | POSSIBLE CAUSE | REMEDY |
|--|--|---|
| Pilot lights but flame goes out when control knob is released. | <ol style="list-style-type: none"> 1. Manual shutoff valve not fully open. 2. Control knob not fully pressed in. 3. Control knob not pressed in long enough. 4. Safety interlock system has been triggered. 5. Thermocouple connection loose at control valve. 6. Pilot flame not touching thermocouple, which allows thermocouple to cool, causing pilot flame to go out. This problem could be caused by any or all of the following: <ol style="list-style-type: none"> A) Improperly adjusted pilot flame B) Low gas pressure C) Dirty or partially clogged pilot 7. Thermocouple damaged. 8. Control valve damaged. | <ol style="list-style-type: none"> 1. Fully open manual shut-off valve. 2. Press in control knob fully. 3. After pilot lights, keep control knob pressed in 30 seconds. 4. Wait one minute for safety interlock system to reset. Repeat ignition. 5. Hand tighten until snug, then tighten 1/4 turn more. 6. A) Contact qualified service person to properly adjust pilot flame B) Contact local natural gas company. C) Clean pilot (see <i>Cleaning and Maintenance</i>, page 23) or replace pilot assembly. 7. Replace thermocouple. 8. Replace control valve. |
| Burner does not light after pilot is lit. | <ol style="list-style-type: none"> 1. Safety interlock system has been inadvertently triggered. 2. Burner orifice is clogged. 3. Burner orifice diameter is too small. 4. Inlet gas pressure is too low. | <ol style="list-style-type: none"> 1. Fully depress control knob in any position other than pilot. Wait one minute for safety interlock system to reset. Repeat ignition. 2. Clean burner (see <i>Cleaning and Maintenance</i>, page 23) or replace burner orifice (see <i>Changing Burner Orifice</i>, page 30). 3. Replace burner orifice (see <i>Changing Burner Orifice</i>, page 30). 4. Contact local natural gas company. |
| Delayed ignition of burner. | <ol style="list-style-type: none"> 1. Manifold pressure is too low. 2. Burner orifice is clogged. | <ol style="list-style-type: none"> 1. Contact local natural gas company. 2. Clean burner (see <i>Cleaning and Maintenance</i>, page 23) or replace burner orifice (see <i>Changing Burner Orifice</i>, page 30). |

TROUBLE-SHOOTING

Continued

| OBSERVED PROBLEM | POSSIBLE CAUSE | REMEDY |
|---|---|--|
| Burner backfiring during combustion. | <ol style="list-style-type: none"> 1. Burner orifice is clogged or damaged. 2. Burner damaged. 3. Gas regulator defective. 4. Delayed ignition. | <ol style="list-style-type: none"> 1. Clean burner (see <i>Cleaning and Maintenance</i>, page 23) or replace burner orifice (see <i>Changing Burner Orifice</i>, page 30). 2. Replace burner. 3. Replace control valve. 4. See above. |
| Yellow flame during burner combustion. | <ol style="list-style-type: none"> 1. Not enough air. 2. Gas regulator defective. | <ol style="list-style-type: none"> 1. Check burner for dirt and debris. If found, clean burner (see <i>Cleaning and Maintenance</i>, page 23). 2. Replace control valve. |
| Slight smoke or odor during initial operation. | <ol style="list-style-type: none"> 1. Residues from manufacturing processes. | <ol style="list-style-type: none"> 1. Problem will stop after a few hours of operation. |
| Burner fails to respond to thermostat. | <ol style="list-style-type: none"> 1. Pilot flame not lit. 2. Pilot flame not properly heating end of thermocouple. 3. Pilot burner orifice clogged or damaged. 4. Control valve defective. 5. Temperature at thermostat bulb satisfied. | <ol style="list-style-type: none"> 1. Light pilot burner (see <i>Lighting Instructions</i>, page 18). 2. Pilot flame needs adjusting. Contact a qualified service person. 3. Clean pilot burner (see <i>Cleaning and Maintenance</i>, page 23). 4. Replace control valve. |
| Heater produces a whistling noise when burner is lit. | <ol style="list-style-type: none"> 1. Air in gas line. 2. Air passageways on heater blocked. 3. Dirty or partially clogged burner orifice. | <ol style="list-style-type: none"> 1. Operate burner until air is removed from line. Have gas line checked by local natural gas company. 2. Observe minimum installation clearances (see Figure 3, page 7). 3. Clean burner (see <i>Cleaning and Maintenance</i>, page 23) or replace burner orifice (see <i>Changing Burner Orifice</i>, page 30). |

TROUBLE-SHOOTING

Continued

WARNING

If you smell gas

- Shut off gas supply.
- Do not try to light any appliance.
- Do not touch any electrical switch; do not use any phone in your building.
- Immediately call your gas supplier from a neighbor's phone. Follow the gas supplier's instructions.
- If you cannot reach your gas supplier, call the fire department.

| OBSERVED PROBLEM | POSSIBLE CAUSE | REMEDY |
|--|---|---|
| Heater produces a clicking/ticking noise just after burner is lit or shut off. | 1. Metal expanding while heating or contracting while cooling. | 1. This is common with most heaters. If noise is excessive, contact qualified service person. |
| Heater produces unwanted odors. | 1. Heater burning vapors from paint, hair spray, glues, etc. 2. Gas leak. See Warning statement at top of page. | 1. Ventilate room. Stop using odor causing products while heater is running. 2. Find and correct all leaks (see <i>Checking Gas Connections</i> , page 13). |
| Heater shuts off in use. | 1. Heater not venting correctly. Vent safety switch shuts off heater. 2. Low line pressure. 3. Pilot partially clogged. | 1. Check venting system. If damaged or blocked, repair. If venting system is OK, have qualified service person replace vent safety switch, wire harness, or thermocouple interrupter. 2. Contact local natural gas company. 3. Clean pilot (see <i>Cleaning and Maintenance</i> , page 23). |
| Gas odor even when control knob is in OFF position. | 1. Gas leak. See Warning statement at top of page. 2. Control valve damaged. | 1. Find and correct all leaks (see <i>Checking Gas Connections</i> , page 13). 2. Replace control valve. |
| Gas odor during combustion. | 1. Foreign matter between control valve and burner. 2. Gas leak. See Warning statement at top of page. 3. Foreign fumes in area of heater being drawn through burner combustion. | 1. Take apart gas tubing and remove foreign matter. 2. Find and correct all leaks (see <i>Checking Gas Connections</i> , page 13). 3. Ventilate area around heater to remove any foreign fumes. |

SERVICE PROCEDURES

Removing Control Valve and Burner Tube

1. Shut off gas supply to heater.
2. Remove lower front access panel on heater.
3. Disconnect burner tube from orifice holder (see Figure 18).
4. Remove pilot gas line from control valve (see Figure 18).
5. Disconnect wire connectors from thermocouple interrupter (see Figure 18).
6. Remove thermocouple and thermocouple interrupter from control valve.
7. Remove cotter pin from control valve. This releases the control rod from valve (see Figure 18).
8. Remove the two mounting screws from control valve mounting bracket (see Figure 18).
9. Remove assembly from the rear of heater. Pull burner tube through hole in combustion chamber.
10. To reinstall, reverse above steps. Turn on gas to heater and check for gas leaks. Apply a mixture of liquid soap and water to all joints. Bubbles forming show a leak. Correct all leaks at once.
11. Replace lower front access panel.

⚠ WARNING

Turn off and unplug heater and let cool before servicing. Unless you need gas supply for testing, shut off manual shutoff valve before servicing. Only a qualified service person should service and repair heater and venting system.

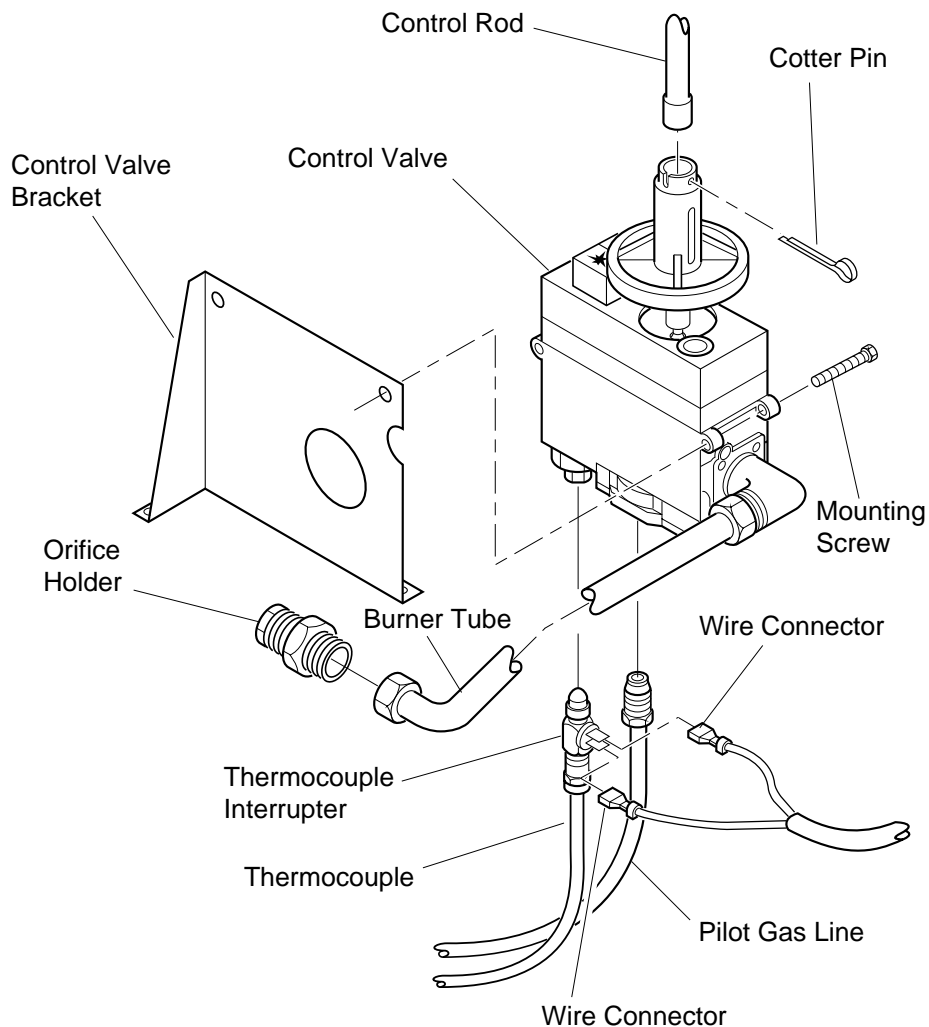

Figure 18 - Removing Control Valve and Burner Tube

SERVICE PROCEDURES

Continued

Removing Burner

1. Shut off gas supply to heater.
2. Remove lower front access panel on heater.
3. Disconnect burner tube from orifice holder (see Figure 19).
4. Remove orifice holder from burner (see Figure 19).
5. Remove pilot burner bracket nuts and remove pilot assembly (see Figure 19).
6. Move burner to the right for clearance. Rotate burner 90° and remove burner through lower front access opening.
7. To reinstall, reverse above steps. Turn on gas to heater and check for gas leaks. Apply a mixture of liquid soap and water to all joints. Bubbles forming show a leak. Correct all leaks at once.
8. Replace lower front access panel.

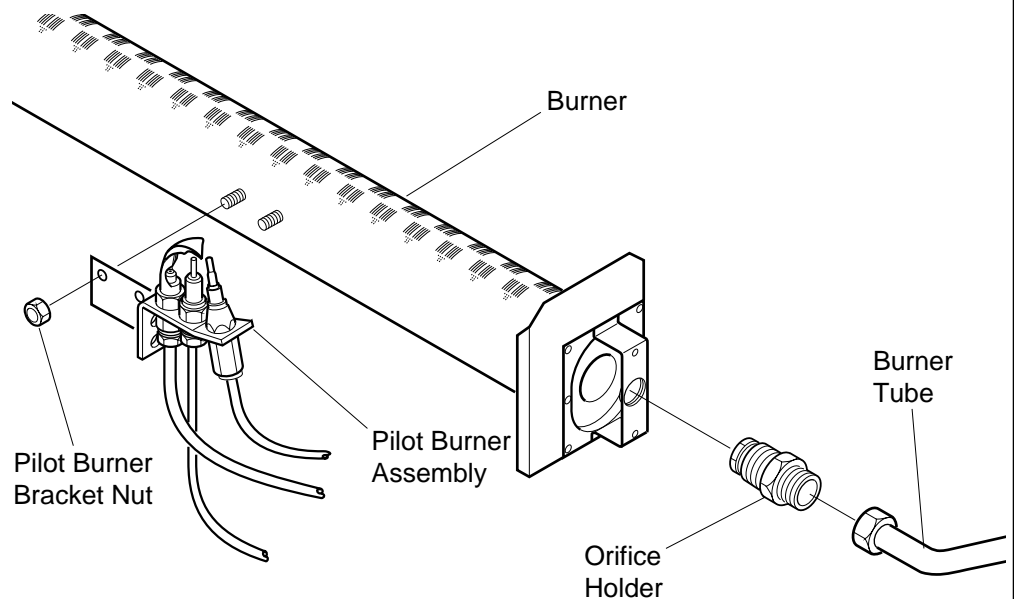

Figure 19 - Removing Burner Tube, Orifice Holder, and Pilot Burner Assembly (35,000 BTU/Hr Burner Shown)

Continued

SERVICE PROCEDURES

Continued

Changing Burner Orifice

1. Shut off gas supply to heater.
2. Remove lower front access panel on heater.
3. Disconnect burner tube from orifice holder (see Figure 20).
4. Remove orifice holder from burner (see Figure 20).
5. Use socket or open-end wrench to remove the old orifice from the orifice holder.
6. Clean and replace orifice, or replace with new orifice.
7. Turn on gas to heater and check for gas leaks. Apply a mixture of liquid soap and water to all joints. Bubbles forming show a leak. Correct all leaks at once.
8. Replace lower front access panel.

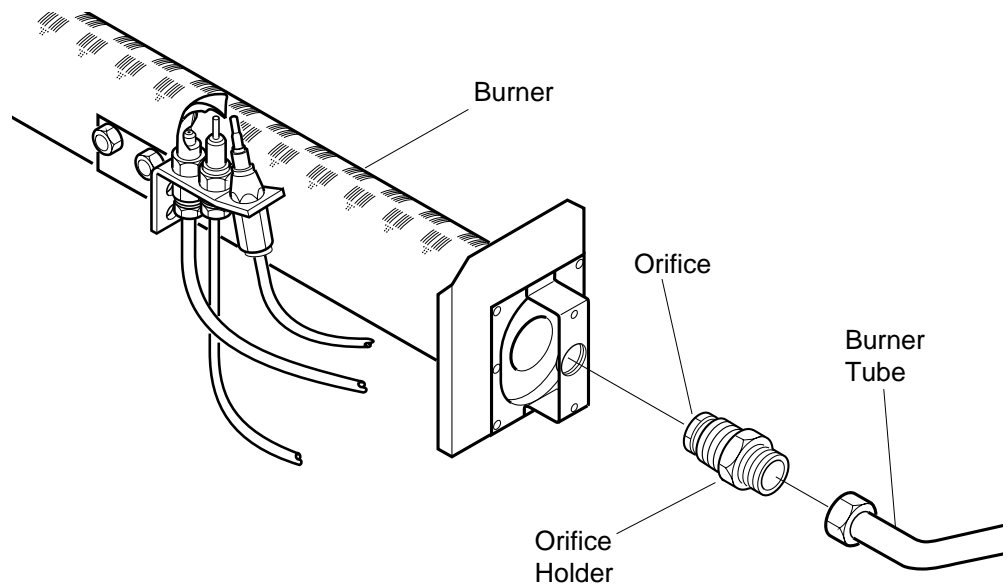

Figure 20 - Orifice Location (35,000 BTU/Hr Burner Shown)

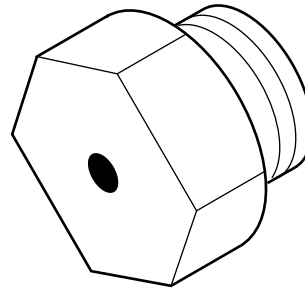
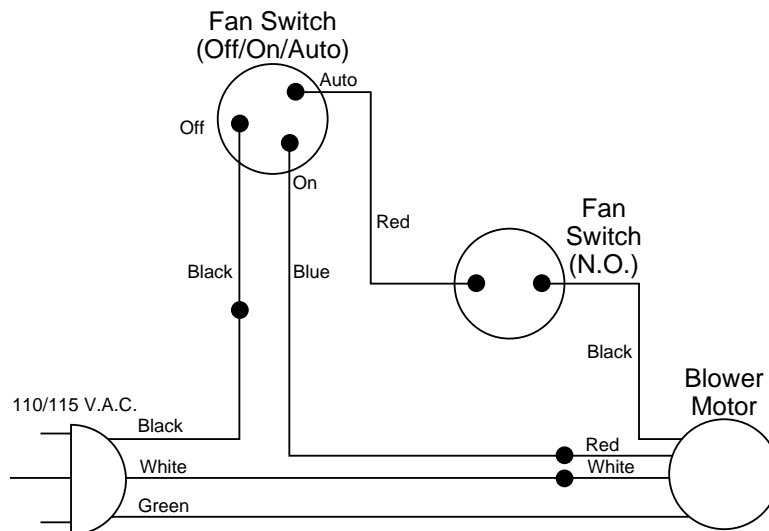

Figure 21 - Orifice

BLOWER WIRING DIAGRAM (For Models With Blower Assembly)



TECHNICAL SERVICE

SPECIFICATIONS

You may have further questions about installation, operation, or troubleshooting. If so, contact DESA International's Technical Service Department at 1-800-323-5190.

| | 35,000 BTU/Hr Model | 50,000 BTU/Hr Model | 65,000 BTU/Hr Model |
|----------------------------|------------------------|------------------------|------------------------|
| BTU | 35,000 | 50,000 | 65,000 |
| Type Gas | Natural Only | Natural Only | Natural Only |
| Ignition | Piezo | Piezo | Piezo |
| Pressure Regulator Setting | 3.5" W.C. | 3.5" W.C. | 3.5" W.C. |
| Inlet Gas Pressure | | | |
| Maximum | 7" W.C. | 7" W.C. | 7" W.C. |
| Minimum | 5" W.C. | 5" W.C. | 5" W.C. |
| Dimensions, Inches | | | |
| Heater (H x W x D) | 25 x 27 1/4 x 16 | 28 x 32 1/2 x 16 | 31 x 37 3/4 x 16 |
| Shipping Weight (pounds) | 78 | 98 | 120 |
| Flue Vent Size | 4" dia. | 4" dia. | 5" dia. |
| Orifice Size | 3.8 mm, ø .1496 | 29 drill, ø .136 | 34 drill, ø .111 |

Note: These heaters are certified for elevations of 0-4500 feet above sea level. For elevations above 2000 feet, de-rate heater 4% for each 1000 feet above sea level.

SERVICE HINTS

When gas pressure is too low

- pilot will not stay lit
- burner will have delayed ignition
- heater will not produce specified heat

When gas quality is bad

- pilot will not stay lit
- burner will produce yellow flames and soot
- heater will backfire when lit

You may feel your gas pressure is too low or gas quality is bad. If so, contact your local natural gas supplier.

ACCESSORIES

Purchase these heater accessories from your local dealer. If they can not supply these accessories, contact your nearest Parts Central (see page 32). You can also write to the address listed on the back page of this manual for information.

BLOWER KIT - PART NUMBER GA6010

For all models. Provides better heat distribution. Makes heater more efficient. Complete installation and operating instructions provided with

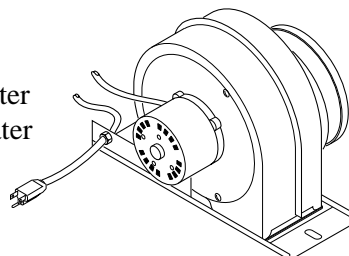

MANUAL SHUTOFF VALVE - GA5010

For all models. Manual shutoff valve with 1/8" NPT tap.

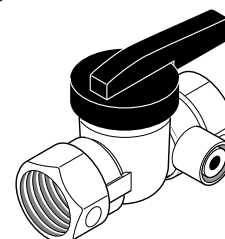

ORDERING REPLACEMENT PARTS

PARTS CENTRALS

Note: Use only original replacement parts. This will protect your warranty coverage for parts replaced under warranty.

Parts Under Warranty

Contact Vanguard dealer or call DESA International's Technical Service Department at 1-800-323-5190. When calling DESA International, have ready

- your name
- your address
- model number of your heater
- how heater was malfunctioning
- type of gas used (propane or natural gas)
- purchase date

Usually, we will ask you to return the defective part to the factory.

Parts Not Under Warranty

Contact Vanguard dealer. If they can't supply original replacement part(s), either contact your nearest Parts Central (below) or call DESA International's Parts Department at 1-800-972-7879 for information. When calling DESA International, have ready

- model number of your heater
- the replacement part number

These Parts Centrals are privately owned businesses. They have agreed to support our customer's needs by providing original replacement parts and accessories. For certain parts, some Parts Centrals may refer you to a dealer in your area. When calling a Parts Central, ask for the Parts Department.

Howard Industries

1514 South Maple Ave.
Los Angeles, CA 90015
213-747-5121

Victor Manufacturing

42 Rumsey Road
E. Hartford, CT 06108
NY, NJ, DE, PA, MD
203-289-4223

Controlled Engineering

299 Roosevelt Road
Glen Ellyn, IL 60137
708-469-7300

Portable Heater Parts

342 N. County Rd 400E
Valparaiso, IN 46383
All States
219-462-7441
1-800-362-6951

FBD

601 Hope Street
Bowling Green, KY 42101
502-796-8406
800-654-8534

American Air Dist.

537 W. 62nd Street
Shreveport, LA 71108
318-861-0634

Master Service Center

1184 Wilson
Grand Rapids, MI 49504
616-791-4760
800-446-1446

Washer Equipment Co.

1715 Main Street
Kansas City, MO 64108
KS, MO, AR
816-842-3911

Controls, Inc.

6820 Glenwood Ave.
Raleigh, NC 27612
NC, SC, VA, MD
919-787-2242
1-800-334-5886

Tarantin Tank Co.

P.O. Box 6129
Freehold, NJ 07728
908-780-9340
800-922-0724

East Coast Energy

707 Broadway
W. Long Branch, NJ 07764
908-870-8809
1-800-755-8809

ATP Services

990 Avenue of Americas
New York, NY 10018
212-967-6255

Dayton Hardware

P. O. Box 275
North Dayton Station
Dayton, OH 45404
All States
513-258-3721
OH only 1-800-762-3426

Central Air Supply

424 North Rockwell
Oklahoma City, OK 73127
405-495-0014

Warmer Image/Halco Enterprises

208 Carter Dr., Unit 21
West Chester, PA 19382
215-696-2670
1-800-368-0803

LaPorte's Parts & Service

2444 North 5th Street
Hartsville, SC 29550
803-879-3009

Cans Unlimited, Inc.

P. O. Box 645
Taylor, SC 29687
All States
803-879-3009
1-800-845-5301

Dealers LP Equip. Co.

P.O. Box 341145
Bartlett, TN 38184
Al, TN
901-386-8780
800-428-8902

Capitol Hydronic Supply

104 West Jefferson Street
Falls Church, VA 22046
703-416-8555

Tuco Industrial Products

P.O. Box 5076
Lynwood, WA 98046
206-743-9533
1-800-735-1268

Auer Steel & Heating Supply

2935 W. Silver Spring Dr.
Milwaukee, WI 53209
414-463-1234

ILLUSTRATED PARTS LIST Cabinet Assembly

This list contains replaceable parts used in your heater. When ordering parts, follow the instructions listed under *Ordering Replacement Parts* on page 32 of this manual.

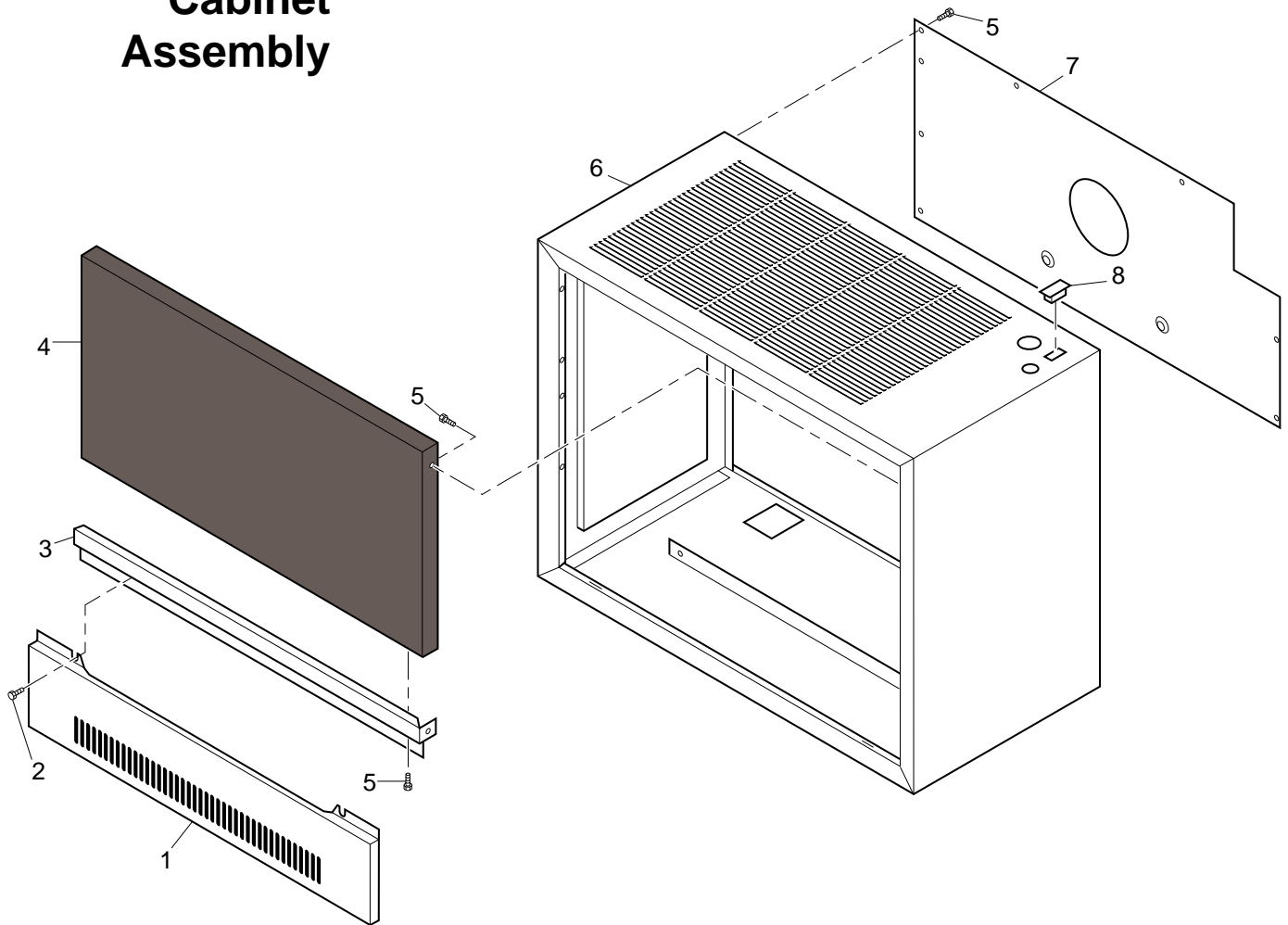

| KEY NO. | PART NUMBER FOR | | | DESCRIPTION | QTY. |
|------------------------------------|-----------------|-------------|-------------|---|------|
| | GVC65NA | GVC50NA | GVC35NA | | |
| 1 | 100202-03 | 100202-02 | 100202-01 | Lower Front Panel | 1 |
| 2 | 098304-01 | 098304-01 | 098304-01 | Screw, #10-24 x 3/8" | 2 |
| 3 | 100046-03BS | 100046-02BS | 100046-01BS | Screen Bottom Trim | 1 |
| 4 | 100049-03BP | 100049-02BP | 100049-01BP | Grill Assembly | 1 |
| 5 | M11084-26 | M11084-26 | — | Screw, #10-16 x 3/8" | 22 |
| | — | — | M11084-26 | Screw, #10-16 x 3/8" | 23 |
| 6 | 100203-03 | 100203-02 | 100203-01 | Cabinet Assembly | 1 |
| 7 | 100101-03BS | 100101-02BS | 100101-01BS | Cabinet Back | 1 |
| 8 | 099997-01 | 099997-01 | 099997-01 | Switch Plug | 1 |
| PARTS AVAILABLE - NOT SHOWN | | | | | |
| | 099988-01 | 099988-01 | 099988-01 | Lighting Instructions Decal, English | 1 |
| | 100157-01 | 100157-01 | 100157-01 | Lighting Instructions Decal, French | 1 |
| | 099987-01 | 099987-01 | 099987-01 | Control Position Decal | 1 |
| | 100154-01 | 100154-01 | 100154-01 | Warning Decal | 1 |

ILLUSTRATED PARTS LIST Burner Assembly

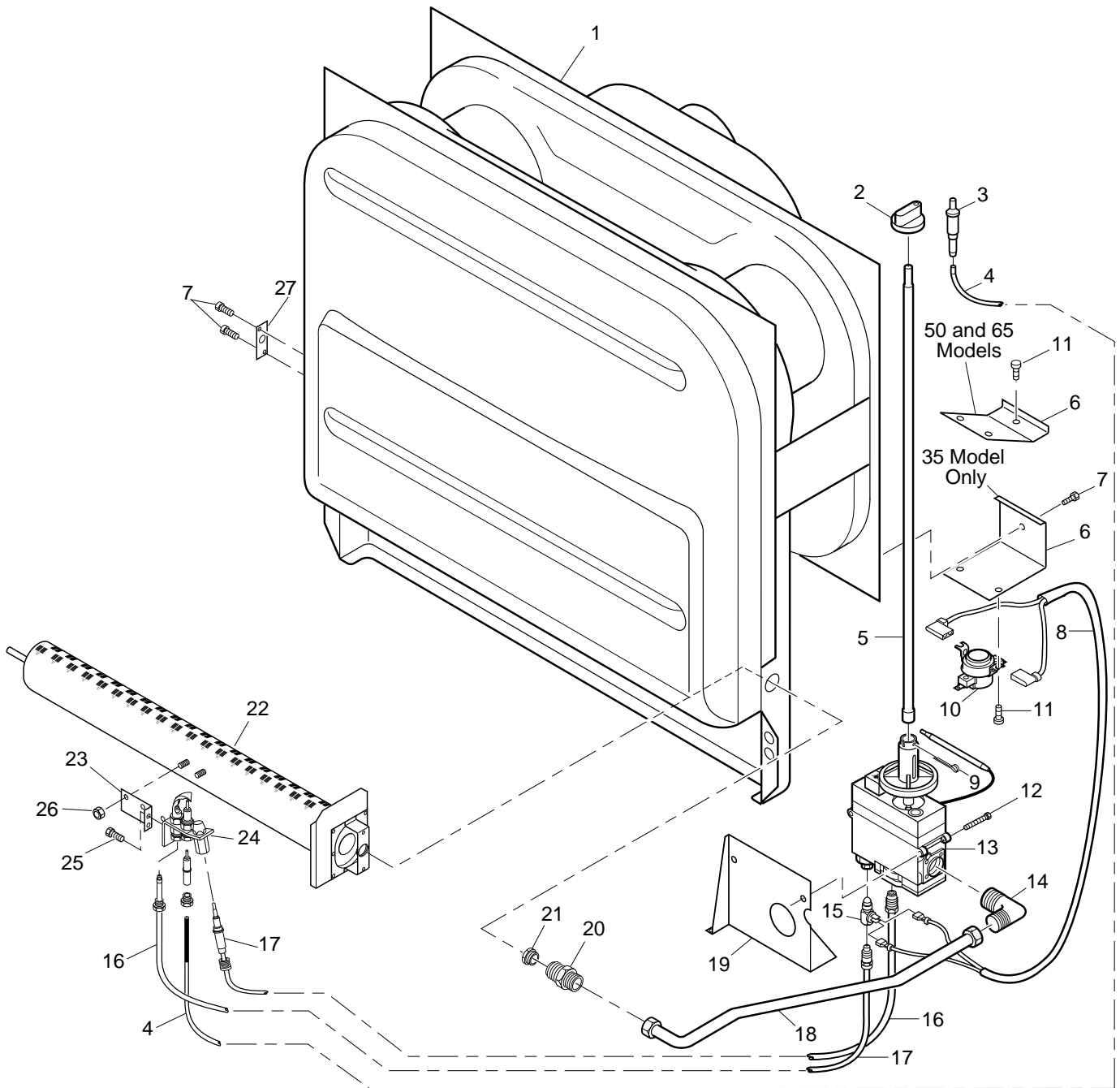

PARTS LIST

Burner Assembly

This list contains replaceable parts used in your heater. When ordering parts, follow the instructions listed under *Ordering Replacement Parts* on page 32 of this manual.

| KEY NO. | PART NUMBER FOR | | | DESCRIPTION | QTY. |
|---------|-----------------|-----------|-----------|--------------------------|------|
| | GVC65NA | GVC50NA | GVC35NA | | |
| 1 | 100729-06 | 100729-05 | 100729-04 | Combustion Chamber | 1 |
| 2 | 098324-02 | 098324-02 | 098324-02 | Control Knob | 1 |
| 3 | 097159-02 | 097159-02 | 097159-02 | Piezo Ignitor | 1 |
| 4 | 098271-05 | 098271-05 | 098271-05 | Ignitor Cable | 1 |
| 5 | 099974-03 | 099974-02 | 099974-01 | Control Rod | 1 |
| 6 | 100482-01 | 100482-01 | 063014 | Limit Switch Bracket | 1 |
| 7 | — | — | M11084-26 | Screw, #10-16 x 3/8" | 3 |
| 8 | 099986-02 | 099986-01 | 099986-01 | Wire Assembly | 1 |
| 9 | 100000-01 | 100000-01 | 100000-01 | Cotter Pin | 1 |
| 10 | 231939 | 231939 | 231940 | Limit Switch | 1 |
| 11 | M11084-38 | M11084-38 | — | Screw, #8-18 x 3/8" | 3 |
| | — | — | M11084-38 | Screw, #8-18 x 3/8" | 2 |
| 12 | 099211-01 | 099211-01 | 099211-01 | Screw, #10-16 x 2 1/4" | 2 |
| 13 | 100207-01 | 100207-01 | 100207-01 | Control Valve | 1 |
| 14 | 098265-01 | 098265-01 | 098265-01 | Elbow | 1 |
| 15 | 098936-02 | 098936-02 | 098936-02 | Thermocouple Interrupter | 1 |
| 16 | 100028-02 | 100028-02 | 100028-02 | Pilot Tubing | 1 |
| 17 | 100307-01 | 100307-01 | 100307-01 | Thermocouple | 1 |
| 18 | 099976-02 | 099976-02 | 099976-02 | Burner Tube | 1 |
| 19 | 530988 | 530988 | 530988 | Control Bracket | 1 |
| 20 | 100309-01 | 100309-01 | 100309-01 | Orifice Holder | 1 |
| 21 | 180257 | 180245 | 180233 | Orifice | 1 |
| 22 | 100706-01 | 100385-01 | 100384-01 | Burner | 1 |
| 23 | 100310-01 | 100310-01 | 100310-01 | Pilot Mounting Bracket | 1 |
| 24 | 100308-01 | 100308-01 | 100308-01 | Pilot | 1 |
| 25 | M12461-25 | M12461-25 | M12461-25 | Screw, #10-32 x 1/4" | 2 |
| 26 | 098249-01 | 098249-01 | 098249-01 | Nut, M5 x 0.8 | 2 |
| 27 | 100090-01 | 100090-01 | 100090-01 | Burner Bracket | 1 |

WARRANTY INFORMATION

Always specify model and serial numbers when communicating with the factory.

We reserve the right to amend these specifications at any time without notice. The only warranty applicable is our standard written warranty. We make no other warranty, expressed or implied.

LIMITED WARRANTY VANGUARD VENTED NATURAL GAS HEATERS

LIMITED ONE YEAR WARRANTY

This DESA product is warranted to the original purchaser to be free from defect in material and workmanship under normal use and maintenance for a period of one year from the date of installation whether or not actual use begins on that date. It is the responsibility of the consumer/owner to establish the warranty period. You are required to furnish proof of installation date, which may be a Bill of Sales or other payment record which verifies the original installation. A new or remanufactured part to replace any defective part will be provided, at DESA's sole option, without charge for the part itself, FOB the shipping point. The exchanged part will be warranted for only the unexpired portion of the original warranty. Defective parts must be returned to DESA, transportation charges prepaid, (DESA is not responsible for any freight charges), where DESA will establish to its sole satisfaction that the part was or became defective under normal use and maintenance. This warranty provides a labor allowance to restore the product to proper operating condition. No reimbursement will be made for transportation, diagnostics, shipping, handling, or other incidental expenses. This warranty applies only to the product in its original installation location and is voided if the product is reinstalled elsewhere.

LIMITED FIVE YEAR WARRANTY ON COMBUSTION CHAMBER

During the second through fifth years after the date of original installation, DESA further warrants the combustion chamber against defects in material and workmanship under normal use and maintenance. A replacement combustion chamber will be provided under the same conditions as stated in the one year warranty.

LIMITED TEN YEAR WARRANTY ON STAINLESS STEEL BURNER

During the second through tenth years after the date of original installation, DESA further warrants the stainless steel burner against defects in material and workmanship under normal use. Should the burner ever need to be replaced due to a defect in material or workmanship, it will be exchanged free of charge upon return of the defective burner to DESA International, freight prepaid, along with the model and serial number of the heater. The burner will not be warranted if broken, altered, or modified in any way. This warranty does not include damages or repairs caused by floods, corrosive atmosphere, abuse, misapplication, unreasonable use, improper servicing, improper operation, or failure to provide reasonable and necessary maintenance. Any and all freight and labor charges incurred are not covered by this warranty and shall be borne by the owner/user.

LIMITATION OF WARRANTIES

All implied warranties (including implied warranties of merchantability) are hereby limited in duration to the period for which each limited warranty is given. Some states do not allow limitations on how long an implied warranty lasts so the above limitations may not apply to you. The expressed warranties made in this warranty are exclusive and may not be altered, enlarged, or changed by any distributor, dealer, or other person whomsoever.

DESA WILL NOT BE RESPONSIBLE FOR:

1. Normal maintenance as outlined in the owner's operation and installation manual including cleaning of component parts; such as, orifices and burners.
2. Failure to start and/or operate due to voltage or gas condition, blown fuses, open circuit breakers, loose or disconnected wires, low gas pressure, or other damages due to inadequacy or interruption of electrical service or gas supply.
3. Damage or repairs required as a consequence of faulty or incorrect installation not in conformance with DESA instructions.
4. Damage as a result of floods, winds, lightning, accidents, corrosive atmosphere, or other conditions beyond the control of DESA.
5. Parts or accessories not supplied by DESA.
6. Costs incurred in gaining access to the heater.
7. Damage or repairs needed as a consequence of any misapplication, abuse, unreasonable use, unauthorized alteration, improper servicing, improper operation, or failure to provide reasonable and necessary maintenance.
8. Freight charges incurred from parts replacement.
9. DESA product installed outside the Continental U.S.A., Alaska, and Canada.
10. DESA products whose serial number has been altered, defaced, or removed.
11. Fuel or electricity costs or increases in such costs from any reason whatsoever.
12. Any special, indirect or consequential property, economic, or commercial damage of any nature whatsoever. Some states do not allow the exclusion of incidental or consequential damages, so the above limitation may not apply to you.

No representative, dealer, or other person is authorized to assume for DESA International any additional, different, or other liability in connection with the sale of this DESA product.

This warranty gives you specific legal rights, and you may also have other rights which vary from state to state.

For more information about this warranty, write:

DESA
INTERNATIONAL
2701 Industrial Drive
P.O. Box 90004
Bowling Green, KY 42102-9004

100749-01
REV. D
12/94

Free Manuals Download Website

<http://myh66.com>

<http://usermanuals.us>

<http://www.somanuals.com>

<http://www.4manuals.cc>

<http://www.manual-lib.com>

<http://www.404manual.com>

<http://www.luxmanual.com>

<http://aubethermostatmanual.com>

Golf course search by state

<http://golfingnear.com>

Email search by domain

<http://emailbydomain.com>

Auto manuals search

<http://auto.somanuals.com>

TV manuals search

<http://tv.somanuals.com>