



Response Er6c Owner's Manual

Diamondback Fitness • 6004 S. 190th Street, Suite 101 • Kent, WA 98032 • Ph: 800.776.7642

DP #: 22-10-1258

Download from www.Somanuals.com. All Manuals Search And Download.

© Diamondback Fitness 2010
PM4360

PURCHASER'S REFERENCE INFORMATION

Product Name: Response Er6c Elliptical by Diamondback Fitness

Serial Number: E _____

Record the serial number here.

Serial Number Location

The serial number will be located on the rear of the unit, above the power input jack (see figure to the right).

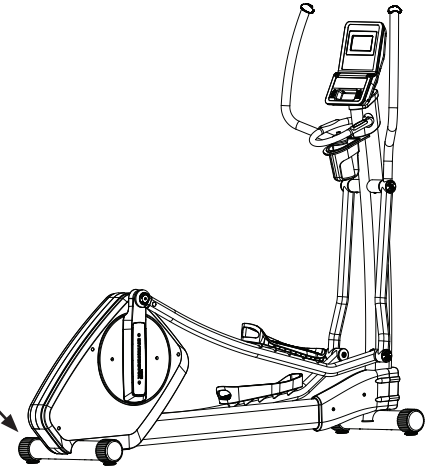
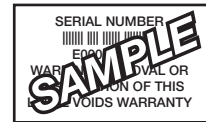

Record of Purchase

NOTE: Please record details associated with the purchase of your Response Er6c below. This information will be required in the event the unit requires future service. ATTACH THE PURCHASE RECEIPT.

Dealer Name: _____ Dealer Telephone Number: () _____

Dealer Address: _____

Date Purchased: _____ Dealer Contact Name: _____

To Activate Your Warranty

Please register the unit at www.diamondbackfitness.com. Failure to comply may limit or void your warranty coverage.

Response Er6c

Owner's Manual

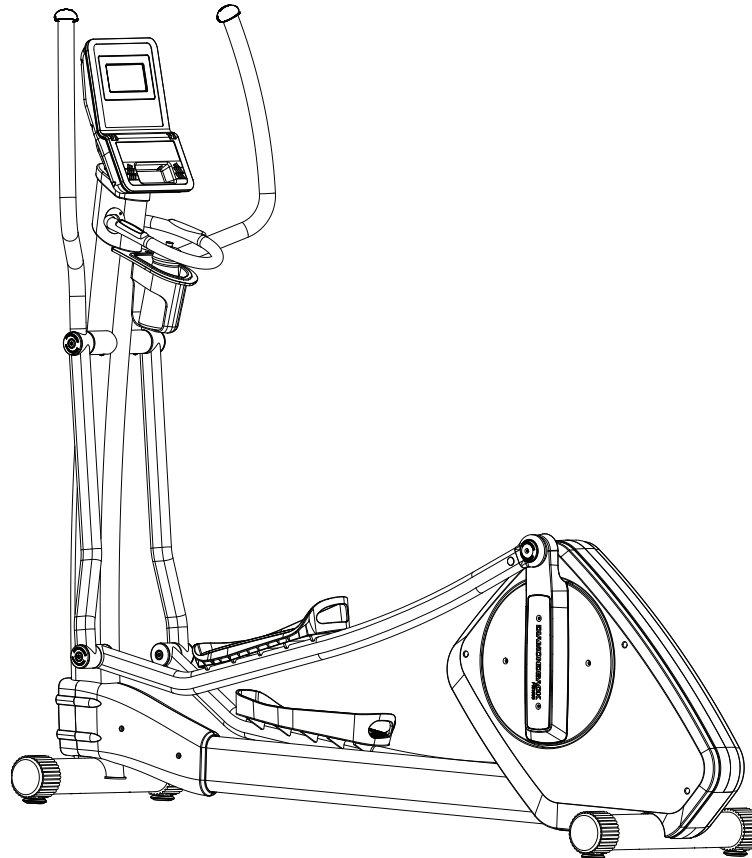

Release v.1 (09/2010)

TABLE OF CONTENTS

PURCHASER'S REFERENCE INFORMATION	2
Serial Number:	2
INTRODUCTION	5
RESPONSE ER6c ASSEMBLY & INSTALLATION.	6
Response Er6c Assembly Instructions	7
SAFETY INSTRUCTIONS & WARNINGS	10
WORKOUT GUIDELINES.	12
Good Health is an Exercise in Common Sense	12
Body Mass Index.	12
Heart Rate is an Important Key to Your Exercise	13
Touch Heart Rate Sensors	13
Wireless Heart Rate Receiver.	13
Your Estimated Maximum Heart Rate & Target Training Zone	14
WORKOUT QUALITY AND QUANTITY	15
CONSOLE LAYOUT.	17
LCD Display Windows	17
Buttons And Keys	19
MP3/iPod Input Jack and Speakers.	20
Default Settings	20
PROGRAMS	21
Quick Start	21
Manual Program	22
Classic Programs.	23
User Program	23
Target Heart Rate	24
MAINTENANCE.	26
WARRANTY INFORMATION	27
WARRANTY REGISTRATION CARD	30

INTRODUCTION

Congratulations on the purchase of your new Response Er6c Elliptical trainer. You have made a smart choice and are about to enjoy one of the most effective and technically-advanced methods of cardiovascular exercise available today.

Founded in 1991 as an off-shoot of the legendary bicycle company, Diamondback Fitness was in many ways a complimentary addition to the Diamondback brand. One might even say this extension grew as a natural evolution...an evolution from classic outdoor bicycle usage, toward indoor-based cycling and cross training. It turns out that many fitness enthusiasts were searching for ways to maintain conditioning during times of inclement weather or were simply looking for new and different cross-training options.

This trend still continues today, twenty years later, as the strong Diamondback brand resonates with both the boomers who grew up with the bicycles, as well as the younger generations riding them today.

Diamondback Fitness continues to build upon this legendary brand identity by offering the cardio enthusiast a full line of upright exercise bicycles, recumbents, and elliptical trainers, each offering superior value and quality in an intuitive and visually-appealing design. Let's just say, we are already planning our next twenty years.

Thank you for choosing Diamondback Fitness.

Diamondback Fitness

6004 South 190th Street, Suite 101 Kent WA 98032 Ph. 1.800.776.7642 Fax: 1.800.776.2073

For more information or questions regarding your equipment, please visit our web site at DiamondbackFitness.com.

RESPONSE ER6c ASSEMBLY

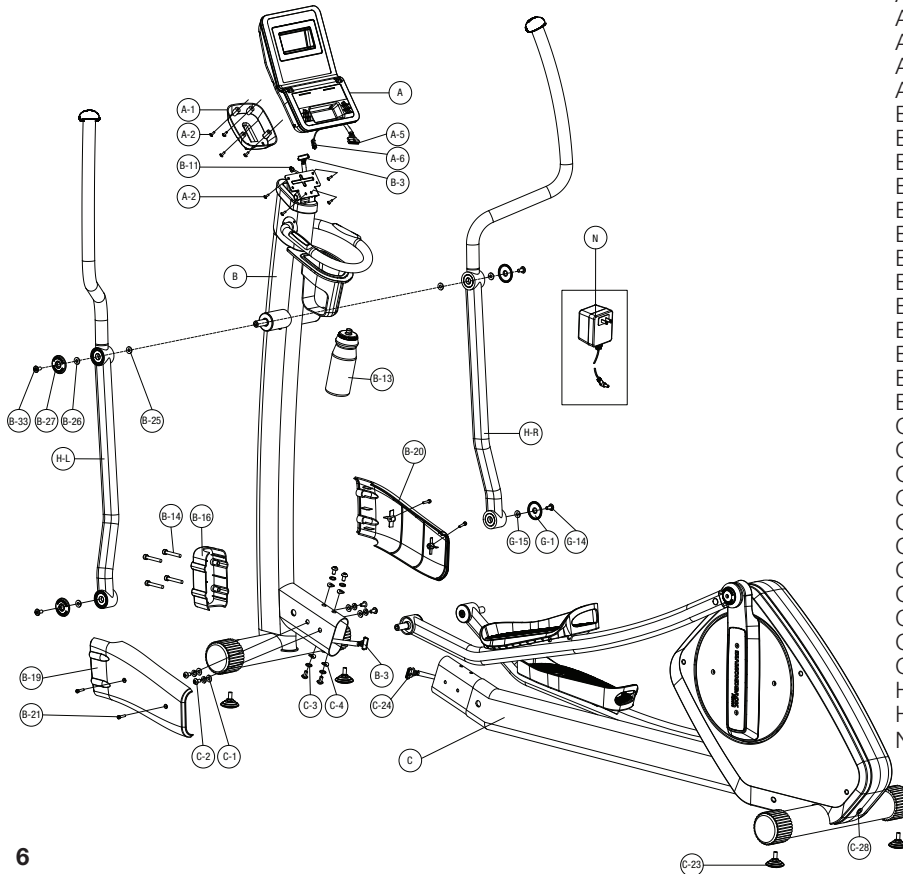

Part Description

- A Console [Quantity: 1]
- A-1 Console Hinge Cover [1]
- A-2 Hex Screw M5 x 0.8 x 10.0 mm [8]
- A-5 Main Wire Harness - Console [1]
- A-6 Heart Rate Wire Harness - Console [1]
- B Console Mast Assembly [1]
- B-3 Main Wire Harness - Console Mast [1]
- B-11 Heart Rate Wire - Console Mast [1]
- B-13 Water Bottle [1]
- B-14 Hex Screw M8 x 1.0 x 55.0 mm [4]
- B-16 Lower Console Mast Cover - Front [1]
- B-19 Lower Console Mast Cover - Left [1]
- B-20 Lower Console Mast Cover - Right [1]
- B-21 Hex Screw M5 x 0.8 x 20.0 mm [4]
- B-25 Flat Washer 17.0 ID x 25.0 OD x 1t mm [2]
- B-26 Flat Washer 8.0 ID x 16.0 OD x 2.0t mm [2]
- B-27 Upper Pivot Cover [2]
- B-33 Hex Bolt M8 x 1.25 x 20 mm [1]
- C Rear Assembly [1]
- C-1 Flat Washer 8.0 ID x 19.0 OD x 2.0t mm [4]
- C-2 Hex Screw M8 x 1.25 x 16 mm [8]
- C-3 Lock Washer 8.1 ID x 12.1 OD x 2.4t mm [8]
- C-4 Curve Washer 8.0 ID x 19.0 OD x 2.0t mm [4]
- C-23 Stabilizer Foot [4]
- C-24 Main Wire Harness - Rear Frame [1]
- C-28 Input Jack [1]
- G-1 Lower Pivot Cover [2]
- G-14 Hex Bolt M8 x 1.25 x 20 mm [2]
- G-15 Flat Washer 8.0 ID x 16.0 OD x 2.0t [2]
- H-L Handlebar Assembly - Left [1]
- H-R Handlebar Assembly - Right [1]
- N 120V to 9V 2A Power Adaptor [1]

Response Er6c

Assembly Hardware Kit / Ensemble du matériel de montage
DP # / DP n° #22-10-1254



Response
by DIAMONDBACK
Fitness

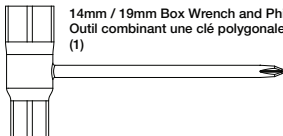

14mm / 19mm Box Wrench and Phillips Screwdriver Combination Tool
Outil combinant une clé polygonale 14 mm/19 mm et un tournevis cruciforme
(1)

3.0 mm, 4.0 mm, 5.0 mm & 6.0 mm Hex Key Set
Ensemble de clés hexagonales de 3,0 mm, 4,0 mm, 5,0 mm et de 6,0 mm
(1)

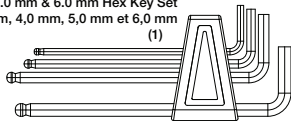

Assembly Notes

- Please read the entire Response Er6c Owner's Manual before beginning the assembly. Review the package contents to ensure all listed parts are included.
- The assembler will require 14 mm & 18 mm box wrenches, 6 mm, 5 mm, 4 mm & 3 mm hex wrenches, and a Phillips screwdriver for assembly. All required tools are included.
- The estimated assembly time of the Response Er6c by a person familiar with basic tool usage is forty-five (45) to sixty (60) minutes.
- Always inspect the unit to ensure handlebars and steparms are tightened prior to using the unit.

ASSEMBLY INSTRUCTIONS

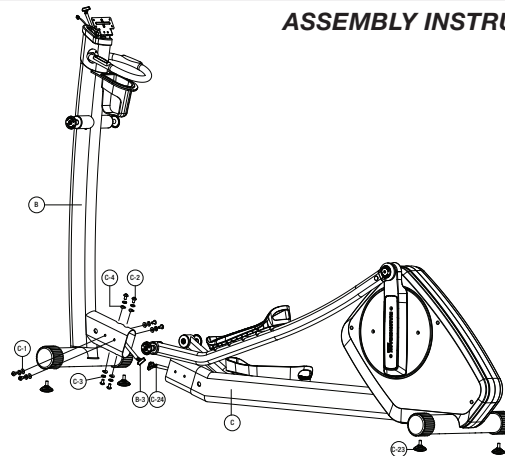

Install the four (4) stabilizer feet **(C-23)**.

Remove the eight (8) hex fixing bolts **(C-2)** and 16 washers **(C-4, C-3 & C-1)** from the console mast **(B)** and set aside.

While supporting the console mast **(B)** and the rear frame **(C)**, connect the lower connector of wire **(B-3)** with connector **(C-24)**. Ensure the connections are solid.

Carefully insert rear frame **(C)** into the receiver of the console mast **(B)** taking care not to pinch the wire harness. Align the holes in the console mast receiver with the bolt holes of the rear frame and re-install bolts **(C-2)**, curved washers **(C-4)**, flat washers **(C-1)** and lock washers **(C-4)**.

Level the unit. If viewed from above, turn the knobs clockwise to raise the feet and counter-clockwise to lower them.

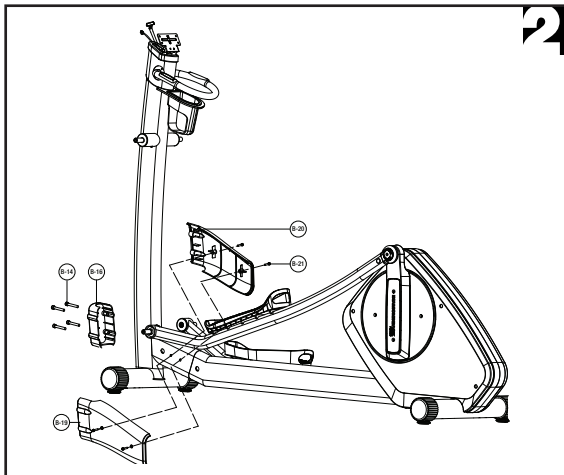

Parts **B-14**, **B-16**, **B-19**, **B-19**, **B-20** & **B-21** will arrive from the factory pre-assembled in the carton. Disassemble by removing bolts **B-14** and **B-21** from parts **B-16**, **B-19** & **B-20**.

Gather the left (**B-19**) and right (**B-20**) lower console mast covers and bring together as a clamshell over the console mast/main frame union. Align covers with the mounting holes and loosely thread the four (4) hex bolts **B-21** into place. Do not tighten yet.

Position the lower console mast front cover (**B-16**) in place and thread the four (4) hex bolts (**B-14**) through the face and into parts **B-19** and **B-20**. Do not over-tighten.

Align and tighten all bolts. Do not over-tighten.

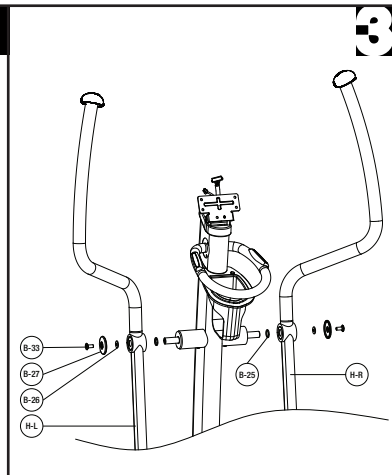

Parts **B-33**, **B-27**, **B-26** & **B-25** will arrive from the factory pre-assembled on the console mast. Remove all components except **B-25** and set aside.

Slide the left (**H-L**) and right (**H-R**) handlebar assemblies over the upper pivot. The fit is designed to be tight so proper alignment is necessary for installation.

Re-install washers **B-26**, pivot caps **B-27** and fixing bolts **B-33**. Tighten bolt **B-33** firmly.

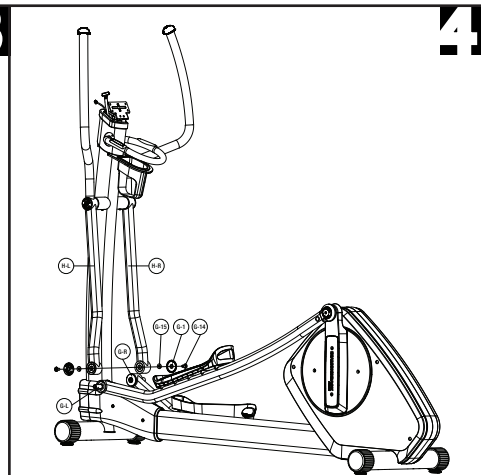

The forward pivots of steparm **G-L** & **G-R** will arrive from the factory with parts **G-15**, **G-1** & **G-14** pre-installed. Remove bolts **G-14**, pivot caps **G-1** & washers **G-15** from the steparms and set aside.

Bring the pivots of the left step arm (**G-L**) and handlebar (**H-L**) together, sliding the handlebar pivot over the step arm pivot axle and press into place.

Re-install washer **G-15**, pivot cap **G-1** and fixing bolt **G-14**. Tighten firmly.

Repeat for right-hand side.

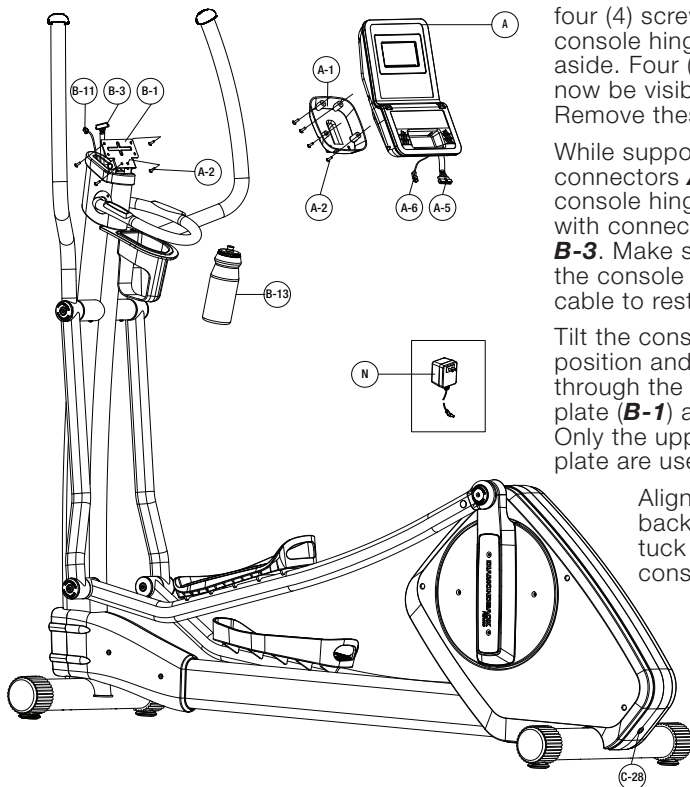

The console hinge cover (**A-1**) is installed onto the console at the factory. Remove the four (4) screws (**A-2**) from the back of the console hinge cover (**A-1**) and set the parts aside. Four (4) more **A-2** Phillips screws will now be visible on the backside of the console. Remove these, and set aside.

While supporting the console (**A**), feed wire connectors **A-6** & **A-5** through inside of the console hinge cover **A-1** and join connector **A-6** with connector **B-11**. Join connectors **A-5** and **B-3**. Make sure all connections are solid. Slide the console hinge cover **A-1** downward on the cable to rest on the console mast.

Tilt the console hinge (**B-1**) to its most upright position and feed the four (4) screws (**A-2**) through the under side of the console mounting plate (**B-1**) and into the back of the console (**A**). Only the upper and lower holes of the hinge plate are used in this step. Tighten firmly.

Align console hinge cover (**A-1**) with the backside of the console, taking care to tuck the wires into the backside of the console or into the console mast.

Feed the four (4) screws (**A-2**) through the back side of the console hinge cover and into the console. Tighten firmly.

Connect the power supply (**N**) to a 120 Volt power source. Insert the opposite end into the power input jack (**C-28**).

5

FINAL SETUP & INSTALLATION

6

Move the unit into final position with the help of the front transport rollers. This unit is heavy. Safe transport may require more than one person. Carefully lift and support the rear end of the unit until both wheels touch the ground. Slowly roll into position.

After moving the unit, ensure all four feet are touching the floor. Review assembly step #1 above for leveling instructions.

Inspect the unit for loose bolts, hardware, knobs or pins.

Plug the AC adaptor in a 120 Volt power supply. Plug the opposite end into the input jack found at the rear of the unit (**CC**).

SAFETY INSTRUCTIONS & WARNINGS

Every piece of Diamondback Fitness equipment is built for maximum safety and meets or exceeds all applicable domestic and international standards. However, certain precautions need to be taken when operating any piece of fitness equipment.

NOTE: Please read the entire owner's manual before operating the unit.

NOTE: Read all warnings posted on the unit. If the warning label to the right is missing from the Er6c elliptical, contact Diamondback Fitness at (800) 776.7642 for a replacement.

Cautions – For Safe Operation

- Keep your hands and feet away from all moving parts and pinch points.
- If you have a history of heart disease, high blood pressure, diabetes, chronic respiratory diseases, elevated cholesterol, or if you smoke cigarettes or experience any other chronic diseases or physical complaints, consult with a physician before beginning any exercise program.
- If overweight, pregnant or above the age of 35, consult your doctor before beginning an exercise program.
- If you experience dizziness, nausea, chest pains or other abnormal symptoms during exercise, stop the exercise session immediately and consult your physician.
- Consume water before, during and after each exercise session.

Warnings – Reduce the Risk of Injury to Yourself or Others

- To ensure proper functioning of your unit, do not install attachments or accessories not provided or recommended by Diamondback Fitness.
- Always wear proper clothing and shoes when exercising.
- Never operate the unit without first verifying that both the handlebar and seat post are firmly fixed.
- Never extend the seat post beyond the MAX marking. See the installation instructions above for proper seat post adjustment.
- User weight is not to exceed 300 pounds / 136.4 kilograms.
- Keep children away from the unit. Hands and feet may become tangled in the moving parts which could result in serious injury.

WARNING!

This Class C product is rated for home (Class H) use only. Use only DIAMONDBACK FITNESS replacement parts. Failure to do so will render the warranty void and could result in personal injury or even death. There is a risk assumed by individuals who use this type of equipment. To minimize the risk, always follow these simple rules:

1. Spining cranks and pedals can cause injury. Only operate unit when seated.
2. Operation of this unit should only commence after the entire Owner's Manual has been read.
3. User weight for the Response U6c is not to exceed 136 kg.
4. Keep children away from unit at all times.
5. Contact DIAMONDBACK FITNESS if you do not understand these warnings, are missing the Owner's Manual, or have questions regarding the proper use and maintenance of this unit.

ES0880 Er6c

- Place the unit in an area that will meet minimum the clearance requirements: Front, Back & Sides = 2 feet.
- This unit is heavy. Use caution when moving. Tilt the unit forward until the integrated transport rollers on the front stabilizer make contact with the ground and slowly push or pull into the desired position. Always unplug the unit from the outlet before moving or servicing.
- Keep the unit away from walls to allow proper ventilation. Air should be able to circulate freely around the unit. Keep all air openings free of dirt and dust.
- Never insert anything into the openings.
- The Response Er6c is intended for indoor use in a home environment. Store indoors in a dry space.
- Place your unit on a solid, level surface when in use. Never operate if the unit is unstable. Review the assembly and installation instructions for information regarding the leveling of the unit.
- Make sure all knobs for adjustments are fastened securely before getting on the unit and after making any adjustments (i.e. seat post, saddle, seat assembly and handlebars).
- Use the handlebars when getting on and off the Response Er6c unit.
- Never operate the unit if it is damaged or broken. Contact your local authorized Diamondback Fitness Dealer for service.
- Please unplug the unit after exercising.
- Do not remove the covers or other components. Only Diamondback Fitness Dealers or Authorized Technicians should perform service on the unit.

Assembly

Assembly of the Response Er6c should be performed by a Diamondback Fitness Dealer or an Authorized Technician as a significant amount of technical knowledge is required for safe and complete assembly of the unit. Many retailers will offer delivery and assembly as part of the sales agreement. If this unit was sold unassembled (in the carton) and you do not feel you can perform the assembly, please call the dealer for service. Service calls for improper assembly are not covered by the Warranty Policy and any associated charges will be the responsibility of the owner.

NOTE: Save this manual for your reference.

WORKOUT GUIDELINES

Good Health is an Exercise in Common Sense

In the study titled, "The Surgeon General's Call To Action To Prevent and Decrease Overweight and Obesity," the surgeon general indicates that 61% of American adults are either overweight or obese. The study indicates that being overweight increases the risk of health problems, such as heart disease, certain types of cancer, as well as Type-2 diabetes among other afflictions.

The Surgeon General's healthy weight advice for consumers encourages the following actions:

- Aim For a Healthy Weight: Find your Body Mass Index (BMI) on the chart below.
- Be Active: Keep physically active to balance the calories you consume.
- Eat Well: Select sensible portion sizes.

Body Mass Index BMI = weight x 703 / height²

		Weight in Kilograms													
		54.5	59.1	63.6	68.2	72.7	77.3	81.8	86.4	90.9	95.5	100.0	104.5	109.1	113.6
Height in centimeters	137.2	29	31	34	36	39	41	43	46	48	51	53	56	58	60
	142.2	27	29	31	34	36	38	40	43	45	47	49	52	54	56
	147.3	25	27	29	31	34	36	38	40	42	44	46	48	50	52
	152.4	23	25	27	29	31	33	35	37	39	41	43	45	47	49
	157.5	22	24	26	27	29	31	33	35	37	38	40	42	44	46
	162.6	21	22	24	26	28	29	31	33	34	36	38	40	41	43
	167.6	19	21	23	24	26	27	29	31	32	34	36	37	39	40
	172.7	18	20	21	23	24	26	27	29	30	32	34	35	37	38
	177.8	17	19	20	22	23	24	26	27	29	30	32	33	35	36
	182.9	16	18	19	20	22	23	24	26	27	28	30	31	33	34
	188.0	15	17	18	19	21	22	23	24	26	27	28	30	31	32
	193.0	15	16	17	18	20	21	22	23	24	26	27	28	29	30
	198.1	14	15	16	17	19	20	21	22	23	24	25	27	28	29
	203.2	13	14	15	17	18	19	20	21	22	23	24	25	26	28

	Healthy Weight
	Over Weight
	Obese

NOTE: Chart applies to adults (age 20 years and older)

Heart Rate is an Important Key to Your Exercise

The Surgeon General also released a report on physical activity and health. This report dictates that exercise and fitness are beneficial for a person's health and reiterated the need for exercise as a key component for disease prevention and healthier living.

The best way to determine exercise intensity is to monitor your pulse during exercise. Heart rate can easily be determined by counting the pulse rate at the chest, wrist or carotid artery on your neck. It is however, difficult to count your own pulse during exercise, mainly because one cannot count fast enough to accurately track the rate. The Response Er6c is equipped with two systems for monitoring your heart rate.

Touch Heart Rate Sensors

While the unit is powered-on and a workout program is operating, gently grasp both touch heart rate sensors on the handlebar. The computer will detect your pulse rate and register a two or three digit number in the PULSE window on the LCD display.

NOTE: If an inconsistent heart rate is displayed while using the hand pulse sensors:

- **Ensure the palms of both hands are touching the contact areas of the touch heart rate sensors.**
- **Maintain even pressure on the grips.**
- **Do not clutch the touch heart rate sensors tightly.**
- **Try to keep your hands still while gripping the touch heart rate sensors.**

Wireless Heart Rate Receiver

A wireless telemetry heart rate receiving system is one feature found on the Response models. In order for the console to detect and display your heart rate, three conditions must be present:

- A compatible *uncoded* heart rate chest strap transmitter (not included) must be functioning and worn. Your Diamondback Fitness dealer can assist you select the appropriate model. Please refer to the manufacturer's instructions.
- The Diamondback Response Er6c must be powered on.
- A workout program must be running.

In general, a wireless heart rate chest strap is a more accurate method of detecting one's heart rate as the user is not required to grip the touch heart rate sensors and the unit will continuously display the heart rate no matter where the hands are placed.

Your Estimated Maximum Heart Rate & Target Training Zone

Your calculated target heart rate, or the ideal intensity needed to improve cardiovascular fitness, depends primarily upon your age rather than your current state of fitness. It is calculated as a percentage of your maximum heart rate (estimated as 220 beats-per-minute minus your age). It is most effective to train at a heart rate between 60% and 85% of your maximum heart rate. If exercise intensity is too low or too high, only modest gains will be made in strength and cardiovascular fitness. A workout at a very low intensity will not offer maximum benefits. Conversely, if the workout intensity is too high, injury or fatigue may set your exercise program back as the body attempts to recover.

To calculate your maximum heart rate and find the target training zone, use the following formulas. For example, the following estimation would be relevant for a 35 year-old user:

- $220 - \text{Age} = \text{Maximum Heart Rate}$ $220 - 35 = 185$
- 60% of Maximum Heart Rate $60\% \times 185 = 111$ heart beats-per minute (Bpm)
- 85% of Maximum Heart Rate $85\% \times 185 = 157$ Bpm
- Calculated Heart Rate Training Zone: $111 \text{ Bpm} - 157 \text{ Bpm}$

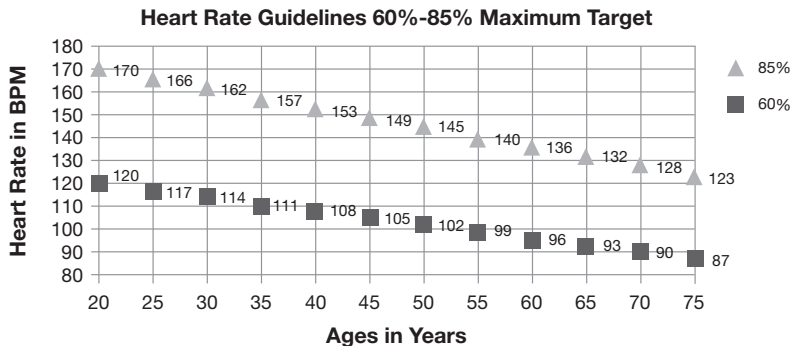

WORKOUT QUALITY AND QUANTITY

It is recommended that you accumulate at least 30 minutes of physical activity most days of the week. Physical activity should be initiated slowly and the intensity should be increased gradually. You should select activities that you enjoy and can fit into your daily life. Having Diamondback Fitness equipment at home offers you the opportunity to work out without going to the gym.

The American College of Sports Medicine makes the following recommendations for the quantity and quality of training for developing and maintaining cardiovascular fitness in healthy adults:

- An activity that uses large muscle groups, maintained continuously, and is rhythmical and aerobic in nature.
- Duration: 20 to 60 minutes of continuous aerobic activity, including a warm-up and cool-down period for each exercise session.
- Frequency: 3 to 5 times per week.
- Intensity: 60% to 85% of maximum heart rate.

In addition to aerobic exercise, it is recommended that you add strength training of moderate intensity twice per week to your program.

Get a Smart Start on Exercising

Anyone over the age of 35, as well as younger persons whom are overweight, should check with his/her physician before beginning any type of exercise program. People who have diabetes or high blood pressure, a family history of heart disease, high cholesterol or have led a sedentary lifestyle should protect themselves with a medical check-up and a stress test, preferably administered during exercise by a health care professional.

- Always stretch before your workout to loosen muscles, and afterwards to cool down.
- The first few minutes of your workout should be devoted to warming up muscles before a vigorous workout, and building your heart rate slowly.

- After an aerobic workout of roughly 20-30 minutes, spend 10 minutes gradually reducing your heart rate with a lower resistance level.

NOTE: Start slow, with intensity low until you build up endurance and strength. Always consult your physician before beginning any exercise program.

Typical Target Zone Exercise Patterns for 35 year-old

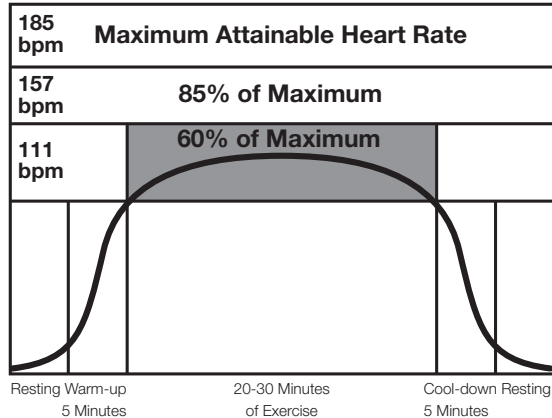

CONSOLE LAYOUT

NOTE: It is advised that new users read this entire section prior to beginning their first workout session.

LCD Display Windows



Time

Tracks the time of the current workout program.



Heart Symbol

Indicates that a heart rate is detected by either the touch heart rate sensors, or the wireless heart rate receiver. If a pulse is not detected, the heart icon will not be visible and the Bpm will be displayed as "P".



Pulse

Your heart rate will be displayed in this field when detected by the touch heart rate sensors or wireless heart rate receiver. Unit of measurement is Bpm/Beats-Per-Minute.



Speed

An estimate of your speed (Kilometers per hour) will be displayed. SPEED will alternate with RPM every five (5) seconds.





RPM

An acronym for Revolutions-Per-Minute, the number of complete revolutions a single pedal makes every 60 seconds. The display for RPM will alternate with SPEED every five (5) seconds.



Load

Displays the current resistance level applied to the workout. The maximum resistance load is 16.



Distance

The estimated total distance (in Kilometers) traveled since the beginning of the workout.



Calories

The estimated number of calories burned since the beginning of the workout will be displayed in this field.

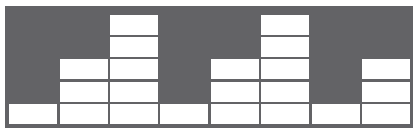

Brickyard or Workout Profile

This field will graphically display the terrain of the workout program. A higher “brick” stack represents a higher load or resistance level. A flashing column of bricks will indicate the user’s progress in the program at any given time. Although only eight (8) columns show in the window, the complete profile is comprised of twenty (20) columns and will advance as the user progresses through the program.



Alpha-Numeric Messaging Bar

Program titles and instructions will be displayed in this field.

Buttons and Keys



RESET

The reset button will return the programming to the program selection menu.

Holding the RESET key down for two seconds restarts the system and enters the User Set-Up mode.



START / QUICK START / STOP

When powering up the unit, it is possible to bypass all data entry and enter the Quick Start program.

Pressing START / QUICK START / STOP while in the Program Set-Up mode will immediately launch the program displayed in the Alpha-Numeric Messaging Bar.

Pressing START / QUICK START / STOP key once while in Program mode will pause the program. Pressing the key again will un-pause the program.



UP / DOWN

During the Program Set-Up mode, press UP or DOWN to adjust the Age, Weight and Time values.

During the Program mode, press UP or DOWN to adjust the resistance level.



ENTER

Within the Set-Up mode, the ENTER key accepts the current program details such as Age and Weight then moves to the next value to be adjusted.

In Program Selection mode, pressing ENTER will accept the displayed program and launch Set Up mode.

FITNESS TEST



FITNESS TEST

At the end of a program, pressing the FITNESS TEST button once will launch the Fitness Test program. Based upon the rate at which the user's heart rate decreases over a sixty (60) second period, the Fitness Test program provides a basic analysis of the user's fitness by displaying F1, F2, F3, F4 F5 or F6 where F1 represent the highest level of fitness.

MP3/iPod Input Jack and Speakers

The Response console offers an on-board amplifier and stereo speaker set which can be connected to an Mp3 player, iPod® or iPhone®. Connect one end of a male-to-male 3.5 mm stereo cable (not included) to the headphone jack of the device and the other end to the console port located just above the accessory tray. Sound levels are controlled by the device so be sure to check the internal settings of the player if the noise level is not satisfactory.

Default Settings

- Gender Male
- Age 25 years
- Weight 50 Kg
- Time 0 minutes. If left at zero, the program time will count up and run continuously until stopped by the user. If an entry is made, the program will count down from the entered value.
- Segment Time Equals 1/20th of the entered time. If 30 minutes is entered for the program time, each segment will equal 90 seconds.
- Load Level 1

NOTE: The default values for Age, Weight and Time will update and be stored as the default values when changed in the program settings.

PROGRAMS – Get Ready to Work Out

When the Response Er6c is plugged into an electrical outlet, an audible beep will sound, confirming power has reached the console. All segments of the display will light up for two seconds. “USER” will flash in the Alpha-Numeric Message Bar.

Quick Start

The Quick Start program offers users the ability to bypass all data entry in the User Select/User Set-Up modes and to immediately begin the Manual workout program by pressing the START / QUICK START / STOP key once. The Quick Start program will run with the default data described in the section titled *User Select Mode and User Set-Up Mode*.

The Time is set at 00:00 minutes and count up until the workout is ended by the user.

User Select Mode and User Set-Up Mode

Immediately following power up (or whenever the RESET key is pressed for two (2) seconds), “USER” will flash in the Alpha-Numeric Message Bar indicating the launching of the User Select mode. From here, customization of the user information (which serves as the data to be used for the heart rate programs, calorie calculations, etc.) can be performed. Another user profile may be selected at any time by pressing the RESET key for two (2) seconds.

- Select User 1, User 2, User 3 or User 4 by pressing the UP or DOWN key to scroll through the choices the pressing ENTER to accept and launch the SET-UP mode.
- “SEX = MALE” will flash in the Alpha-Numeric Messaging Bar. Press ENTER to accept this value or change the value by pressing the UP or DOWN keys until the preferred value is visible. Press ENTER to accept.
- “AGE = 25” will flash. Press ENTER to accept, or change via the UP/DOWN keys, followed by the ENTER key.
- “HEIGHT = 160” will flash. Press ENTER to accept, or change via the UP/DOWN keys, followed by the ENTER key.
- “WEIGHT = 50” will flash. Press ENTER to accept, or change via the UP/DOWN keys.

- Pressing the ENTER key will launch the Program Select mode.
- Load / resistance may be adjusted via the UP or DOWN keys.
- To end the program, press START / QUICK START / STOP or simply stop pedaling.

Program Select Mode

The Program Select mode allows the user to choose their desired program and customize the data and information required to operate these programs.

To enter the Program Select mode:

- From the User Select or User Set-Up modes, press the START key twice, followed by the RESET key.
- From an operating program, press the START / QUICK START / STOP key, followed by the RESET key.

The Program Select mode will always default to the Manual program. “Manual” will flash in the Alpha-Numeric Messaging Bar.

Select the Manual program by pressing the ENTER key, or scroll through the various programs by pressing the UP / DOWN keys, confirming a selection by pressing the ENTER key.

Manual Program

The Manual program is unique in that the user can select any quantity of the four possible values to track this program. When the first of the target values is reached, an audible alarm will sound indicating the end of the program. This function is especially useful for tracking a “personal best” or structuring a challenge of distance versus. time, for example.

- When the Manual program is selected, “Time” will flash, prompting the user to adjust the length of the workout.
- Adjust the time using the UP and DOWN keys. Press ENTER to accept the value.

NOTE: For all programs which accept a Time value, each column in the brickyard represents 1/20th of the total time entered. For example, if the value entered for Time was 30 minutes, each column/segment in the profile will equal 1.5 minutes (30 minutes / 20 segments = 1.5 minutes).

NOTE: When the user is prompted for a Time entry, a value of zero (0:00) will set the clock to count up from zero (00:00). When another value is entered, the clock will count down when the program is launched.

- “Distance” will now be flashing. Adjust the value and press ENTER to accept.
- “Calories” will flash. Adjust and press ENTER.
- “Pulse” will be flashing. Press ENTER once the desired value has been selected.
- If all data fields remain at the default values of zero (0), the program will operate as the Quick Start program. Otherwise, the Manual program will run until the first of the entered values are reached.

NOTE: While entering data, two short beeps signifies that all data fields have been updated. Press ENTER to launch the program.

Classic Programs

When Programs is selected, the brickyard will display the profile associated with first program in the list of available “classic” programs.

- Press the UP or DOWN keys repeatedly to scroll through the six (6) program options and the linked profiles; Interval 1, Interval 2, Hill Climb 1, Hill Climb 2, Hill Climb 3 and Fat Burner.
- Select a program and profile by pressing ENTER.
- Adjust the workout Time, and press START / QUICK START / STOP to begin the program.

User Program

When User Program is selected, the brickyard will display the last profile entered by the user (or the default, flat profile if this program has never been altered).

- The first column in the brickyard will flash and the Alpha-Numeric Messaging Bar will read “S01”. S01 refers to the first segment or column in the brickyard. Adjust the resistance, or load, of the first segment/column in the program profiles

up or down using the UP and DOWN keys. The load will be displayed in the lower left corner of the console. Press ENTER to advance to the next column. Make any desired adjustments to the resistance and repeat the process for all twenty (20) columns. Once all profile adjustments are complete, press and hold the ENTER key for one (1) second to accept the updates.

- “Time” will flash. Adjust the value and press START / QUICK START / STOP to launch the program.
- Changes to the current segment’s load can be made once the program is launched by pressing the UP or DOWN key.

Target Heart Rate / Target HR

Diamondback’s Target Heart Rate programs can also be described as *heart rate control programs*. Heart rate control programs automatically increase and decrease the load during the workout to stay within four (4) Bpm (Beats-Per-Minute) of the target. For example, if the heart rate target is 132 Bpm, and the user’s pulse begins to fall, the Response U6c computer will slowly increase the load. Eventually, the amount of work being performed by the user will increase and so will the heart rate. Conversely, if the user’s heart rate climbs above the target zone, the load will be reduced, ultimately decreasing the heart rate.

The advantages of heart rate control programs are the simplicity and accuracy by which the ideal cardiovascular training zone is maintained thereby offering a very efficient workout.

For the Target Heart Rate programs to operate, the computer must receive a heart rate signal from the touch heart rate sensors or via a wireless chest strap transmitter (not included). If no signal is detected, the Alpha-Numeric Messaging Bar will display “Input Pulse” and “P” will be lit in the Pulse window.

Calculated Maximum Heart Rate is a formula based upon the user’s age: $220 - \text{Age} = \text{Calculated Maximum Heart Rate}$. See the section above titled “Your Estimated Maximum Heart Rate.” As such, the Target Heart Rate programs rely upon an accurate user profile to provide a safe and effective workout. The user must select a user profile which contains the correct age value. To return to the User Set-Up mode and update the age entry, press and hold the RESET key for two seconds. Select a user profile

(User 1, User 2, User 3 or User 4) and update any inaccurate values. See the section “User Select Mode and User Set-Up Mode” above for more information.

A user may bypass the User Set Up mode and run an effective heart rate control program by selecting the Fixed Target program option, and entering a heart rate value in Bpm/Beats-per-minute.

- When Target HR is selected from the Program Selection mode, the Alpha-Numeric Messaging Bar will flash “Target 55.” “Target 55” represents a heart rate target of 55% of the current user’s calculated maximum heart rate. Likewise, “Target 75” and “Target 95” represent 75% and 95% of the user’s calculated maximum heart rate respectively. “Fixed Target” is similar to the percentage targets but rather than the computer calculating the heart rate target, the user may enter a numeric value which will become the heart rate (Bpm) control target.
- Select a program by pressing ENTER.
- If Fixed Target was selected, “Pulse” will flash. Enter a value and press ENTER. If *Target 55*, *Target 75* or *Target 95* were selected, go to the next step.
- “Time” will flash. Adjust the value for this field, and press START / QUICK START / STOP to launch program.

MAINTENANCE

All Response Fitness products are manufacturer by Diamondback Fitness and as such are engineered for years of near-silent operation. Let noise be your first indication that a repair or adjustment is required. Please, discontinue use immediately and contact an Authorized Service Technician or Diamondback Fitness Dealer if an unusual noise, scraping, knocking, grinding or vibration is detected. Often, a minor issue will become a major repair if ignored and use is continued.

Store the unit in a cool and dry environment.

Prior to each workout, confirm that all adjustment knobs are tightened, seat pins are engaged, and handlebars remain fixed. Inspect the pedals and cranks by pressing down firmly upon both at the same time, followed by pulling up. If any play is detected, discontinue use immediately and seek help.

NOTE: As part of the Response Er6c normal installation and set-up process, all cranks must be tightened after 8 to 10 hours of use to ensure the parts are properly seated onto the axle. This important task is part of the initial break-in service as non-tightened cranks will become loose, ultimately requiring replacement. Damage of this type is only caused by under-tightened cranks and is not covered under the Warranty Policy. Tools have been provided for this service.

Your Response Er6c is manufactured of the most durable materials available. The plastics are made of strong and chemical-resistant ABS. The frame is produced of high-tensile steel and protected with an industrial-grade, powder-coating paint for the highest grade of corrosion resistance. The seats are covered with sealed polyester. However, it is important to note that perspiration can be extremely corrosive if allowed to accumulate on the machine. After training, always wipe down your unit with a mild soap solution followed by a thorough drying with a clean towel. Locating a small spray bottle and towel near the unit will help ensure that your Response Er6c looks new for many years.

NOTE: Perspiration is very corrosive and if allowed to remain on the machine, will cause discoloration, fading, rust and odors. Unfortunately, these conditions are not covered under the Warranty Policy.

WARRANTY INFORMATION

Diamondback Fitness warrants your Response Er6c to be free from defects in material and workmanship under normal use in the home environment. Diamondback Fitness's obligation under this warranty is limited to the repair or replacement of any defective part, provided free of charge through an Authorized Service Agent. This warranty is extended to the original purchaser. The following conditions apply:

Who is Covered

The warranty is extended to the individual whose name appears on the Warranty Registration filed with Diamondback Fitness and may not be transferred to any other individual or legal entity. In the absence of a valid Warranty Registration, the original sales receipt will serve as satisfactory documentation of the valid warranty status.

To Obtain Service

To obtain service, you must contact your Authorized Service Technician or Diamondback Fitness. An Authorized Service Agent must diagnose your unit to begin the warranty claim process. Please call **1-800-776-7642**

Warranty Registration

Warranty commitments are valid only with a completed Warranty Registration. Registration is available online at www.diamondbackfitness.com. Alternatively, a warranty card may be mailed to Diamondback Fitness. (See page 30)

Proof of Purchase

Proof of purchase from a Diamondback Fitness Authorized Dealer will be required if the Warranty card is not registered prior to any consideration of a warranty claim.

What is Covered – For Interior Residential Use Only.

- Frame Limited lifetime warranty, covers defects in welds, materials, and workmanship (some exclusions apply).
- Brake Limited lifetime warranty
- Parts & Electronics 1 year
- Labor 1 year
- Wear Items 90 days

Note: *Limited lifetime refers to warranty coverage of the unit's expected service life, not the lifetime of the purchaser. The expected lifetime of the Response Er6c is five (5) years from the date of purchase although other factors can extend this period. Support and maintenance of the unit may become difficult or impossible after this period expires.*

Voided Warranty

The warranty does not apply to any failure of the product or its components due to alterations or modifications, misuse and abuse, accidental damage, lack of maintenance or improper assembly. Improper assembly can be avoided if the unit is assembled by an authorized technician. Damage due to improper assembly is not covered by the warranty. Common assembly errors can include damaged wire harnesses, stripped crank arms, stripped pedals, or damaged threads.

If the serial number has been removed, altered or defaced, the warranty for the affected unit is voided.

Parts & Service

To obtain part or service, please contact Diamondback Fitness or an Authorized Service Technician. To locate a local Authorized Service Technician visit our dealer locator site at www.diamondbackfitness.com or call **1-800-776-7642**.

Note: *Authorized service technicians do not reside in all areas of the country. If you live beyond the reasonable service area of a metropolitan area, Diamondback Fitness may not be able to support the labor portion of the product warranty. Technician travel charges are not covered by the warranty.*

Other Exclusions

The warranty is void if the Response Er6c is placed in commercial or light commercial environments such as health clubs, schools, hotels, condominium common areas, correctional facilities, or any other non-residential setting.

The warranty will not be honored if the Response U6c is employed for commercial or rental purposes.

The Response U6c is for indoor use only.

Additional Rights

This Warranty is expressly in lieu of all other warranties, and any implied warranties of merchantability or fitness for a particular purpose created hereby, and are limited to the same duration as the express warranty herein. Diamondback Fitness shall not be liable for any incidental or consequential damages. Some states do not allow the exclusion or limitations of implied warranties, incidental or consequential, so the above limitations and exclusions may not apply to you.

Retailers and wholesale outlets for Diamondback Fitness products are not authorized to modify this warranty in any way.

This warranty gives the original owner specific legal rights. Other additional rights may vary from state to state.

Free Manuals Download Website

<http://myh66.com>

<http://usermanuals.us>

<http://www.somanuals.com>

<http://www.4manuals.cc>

<http://www.manual-lib.com>

<http://www.404manual.com>

<http://www.luxmanual.com>

<http://aubethermostatmanual.com>

Golf course search by state

<http://golfingnear.com>

Email search by domain

<http://emailbydomain.com>

Auto manuals search

<http://auto.somanuals.com>

TV manuals search

<http://tv.somanuals.com>