



ZTR[®] Mowers

1999 Operator's Manual

6000
SERIES
FORWARD MOUNT

IMPORTANT - READ CAREFULLY

The Dixon® ZTR® Mower is both easy and fun to operate. However, any power mower must be operated properly to be safe. It is not a toy or a recreational vehicle. Before you start to use the mower, read the operator's manual carefully and become completely familiar with the controls.

The information in this operator's manual applies to all Dixon® ZTR® 6000 Series Commercial Mowers. Your Dixon dealer will gladly answer any questions.

See your dealer for warranty service, parts and repairs.



DIXON INDUSTRIES, INC.
A BLOUNT International Inc. Co.
PO BOX 1569
COFFEYVILLE KS 67337 0945
316 251 2000

BLOUNT

INDEX

SAFETY	Pages	4-9
WARRANTY POLICY	Page	10
SPECIFICATIONS	Page	11
SEAT ADJUSTMENT INSTRUCTIONS.....	Page	12
CONTROLS	Pages	13-16
OPERATION INSTRUCTIONS	Pages	17-21
CARE AND MAINTENANCE	Pages	22-34
STANDARD SERVICE PARTS LIST	Page	35
TROUBLESHOOTING	Pages	36-37

**6000 Series Forward Mount
Part No. 13090-0700**

SAFETY

RIDING LAWNMOWERS, IF IMPROPERLY OPERATED, CAN CAUSE SERIOUS INJURY OR DEATH

The most common causes of injury to the operator or bystander...

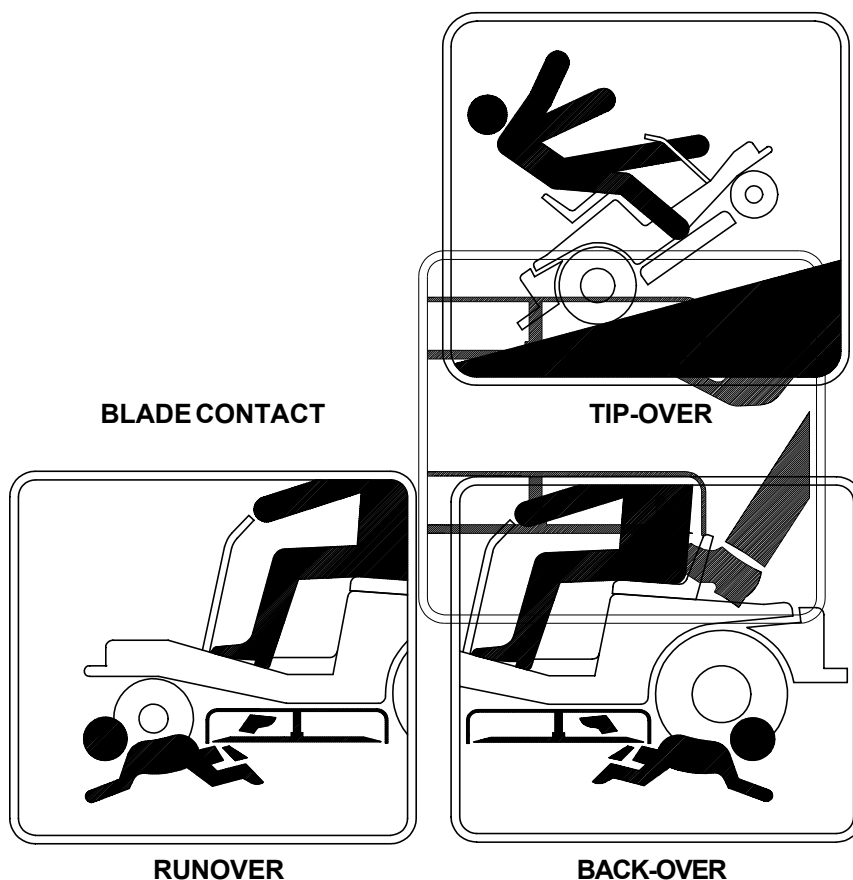

...read and understand this manual to prevent injuries.

SAFETY

SAFETY SYMBOLS



Safety Alert Symbol

When you see this symbol,
BE ALERT to the potential for injury.

Follow recommended safety precautions and safe operating practices.



Danger

indicates an imminently hazardous situation which, if not avoided, will result in death or serious injury.



Warning

indicates a potentially hazardous situation which, if not avoided, could result in death or serious injury.



Caution

indicates a potentially hazardous situation which, if not avoided, may result in minor or moderate injury. It may also be used to alert against unsafe practices.

 **SAFETY**

This cutting mower is capable of amputating hands & feet, and throwing objects. Failure to observe the following safety instructions could result in serious injury or death.

GENERAL OPERATION:

- Read, understand, and follow all instructions in the manual and on the mower before starting.
- Only allow responsible adults, who are familiar with the instructions, to operate the mower.
- Clear the area of objects such as rocks, toys, wire, etc., which could be picked up and thrown by the blade.
- Be sure the area is clear of other people before mowing. Stop mower if anyone enters the area.
- Never carry passengers.
- Do not mow in reverse unless absolutely necessary. Always look down and behind before and while backing.
- Be aware of the mower discharge direction and do not point it at anyone. Do not operate the mower without either the entire grass catcher or the deflector in place.
- Slow down before turning.
- Never leave a running mower unattended. Always turn off blades, set parking brake, stop engine, and remove key before dismounting.
- Turn off blades when not mowing.
- Stop engine before removing grass catcher or unclogging chute.
- Mow only in daylight or good artificial light.
- Do not operate the mower while under the influence of alcohol or drugs.
- Watch for traffic when operating near or crossing roadways.
- Use extra care when loading or unloading the mower into a trailer or truck. Do not ride the mower when loading & unloading.
- Always wear safety goggles or safety glasses with side shields when operating mower.
- Data indicates that operators, age 60 years and above, are involved in a large percentage of riding mower-related injuries. These operators should evaluate their ability to operate the riding mower safely enough to protect themselves and others from serious injury.
- Follow the manufacturer's recommendation for wheel weights or counterweights.
- Maintain or replace safety and instruction labels, as necessary.

 **WARNING:** *The engine exhaust from this product contains chemicals known to the State of California to cause cancer, birth defects or other reproductive harm.*



SAFETY

SLOPE OPERATION:

Slopes are a major factor related to loss-of-control and tip-over accidents, which can result in severe injury or death.

All slopes require extra caution.

If you cannot back up the slope or if you feel uneasy on it, do not mow it!

DO

Mow across the slope with your Dixon ZTR - never up or down.

Remove obstacles such as rocks, tree limbs, etc.

Watch for holes, ruts or bumps. Uneven terrain could overturn the mower. Tall grass can hide obstacles.

Use slow speed. Tires may lose traction on slopes even though the brakes are functioning properly.

Use extra care with grass catchers or other attachments. These can change the stability of the mower.

Keep all movement on the slopes slow and gradual. Do not make sudden changes in speed or direction.

Avoid starting or stopping on a slope. If tires lose traction, disengage the blades and proceed slowly down the slope.

If front wheels lift off the ground, pull the levers back to stabilize the mower.

DO NOT

***Do not* turn on slopes unless necessary, and then, turn slowly and gradually downhill, if possible.**

***Do not* mow near drop-offs, ditches, or embankments. The mower could suddenly turn over if a wheel is over the edge of a cliff or ditch, or if an edge caves in.**

***Do not* mow on wet grass. Reduced traction could cause sliding.**

***Do not* try to stabilize the mower by putting your foot on the ground.**

***Do not* use grass catcher on steep slopes.**



SAFETY

Tragic accidents can occur if the operator is not alert to the presence of children.

Children are attracted to lawn mowers and the mowing activity.

NEVER assume children will stay where they were last seen.

Be alert to avoid accidents.

- **Keep children out of the mowing area and under the watchful care of another responsible adult.**
- **Be alert and turn mower off if a child enters the area.**
- **Before and during backing, look behind and DOWN for small children.**
- **Never carry children. They may fall off and be seriously injured or interfere with safe mower operation.**
- **Never allow children to operate the mower.**
- **Use extra care when approaching blind corners, shrubs, trees, or other objects that may obscure vision.**



SAFETY

SERVICE:

- Use extra care in handling gasoline and other fuels. They are flammable and vapors are explosive.
 - Use only an approved container.
 - Never remove gas cap or add fuel with the engine running. Allow engine to cool before refueling. Do not smoke.
 - Never refuel the mower indoors.
 - Never store the mower or fuel container inside a building where there is an open flame.
 - If fuel is spilled on clothing, change clothing immediately.
 - To prevent fire and explosion caused by static electricity:
 - Never fill containers inside a vehicle or on a truck or trailer bed with a plastic liner. Always place containers on the ground away from your vehicle before filling.
 - When practical, remove gas-powered equipment from the truck or trailer and refuel it on the ground. If this is not possible, then refuel such equipment on a trailer with a portable container, rather than from a gasoline dispenser nozzle.
 - If a gasoline dispenser nozzle must be used, keep the nozzle in contact with the rim of the fuel tank or container opening at all times until fueling is complete. Do not use a nozzle lock-open device.
- Never run a mower inside a closed area. The exhaust fumes are toxic.
- Keep nuts and bolts tight, especially blade attachment bolts, and keep equipment in good condition.
- Never tamper with safety devices. Check their proper operation regularly.
- Keep mower free of grass, leaves, or other debris buildup. Clean up oil or fuel spillage. Allow mower to cool before storing.
- Stop and inspect the equipment if you strike an object. Repair, if necessary, before restarting.
- Never make adjustments or repairs with the engine running.
- Grass catcher components are subject to wear, damage, and deterioration, which could expose moving parts or allow objects to be thrown. Frequently check components and replace with original equipment parts, when necessary.
- Mower blades are sharp and can cut. Wrap the blade(s) or wear gloves, and use extra caution when servicing them.
- Batteries contain sulfuric acid. To prevent burns avoid contact with skin, eyes and clothing. To prevent a fire or explosion keep sparks and open flames away from battery.
- Before disconnecting the negative (-) ground cable, make sure all switches are OFF.

DIXON INDUSTRIES, INC.
a BLOUNT company
AIRPORT INDUSTRIAL PARK
PO BOX 1569
COFFEYVILLE KS 67337 0945
316 251 2000
FAX 316 251 4117



DIXON LIMITED WARRANTY POLICY - COMMERCIAL MODELS

Models 6000 & 7000

WARRANTY: Home Owner Application: This Dixon Warranty term is for a period of two (2) years from date of purchase. Commercial Application: Dixon mowers used for commercial application are warranted for 1 year from the date of purchase or 400 hours whichever comes first. Commercial use is specified as use other than, or in addition to, mowing at owner's primary place of residence.

DIXON ZTR MOWERS ARE WARRANTED AGAINST DEFECTS IN MATERIALS AND WORKMANSHIP AND PROVIDES FOR REPLACEMENT OR REPAIR OF PARTS INCLUDING LABOR COSTS. THIS WARRANTY IS SUBJECT TO THE FOLLOWING CONDITIONS AND LIMITATIONS:

1. Warranty applies only to original retail purchaser of new and unused mowers and accessories.
2. All Dixon warranty must be accomplished by authorized Dixon dealers and in accordance with Dixon warranty policy and allowances. All warranty claims must be approved by Dixon Industries, Inc.
3. Battery warranty: Limited to 90 days from date of purchase.
4. Accessories Warranty (Grass Catchers, Snow Blades, Covers, etc.): Limited to 90 days from date of purchase.
5. Warranty does not apply to damage in transit or incidents of misuse, negligence, accidents, or alteration. The use of parts or components other than those supplied by Dixon Industries, Inc. VOIDS ALL WARRANTY.
6. The following items are not covered by this warranty policy:
 - (a) Pick up and delivery charges for transportation of mower to and from an Authorized Dixon dealer's place of business.
 - (b) Routine maintenance or adjustments.
 - (c) Belts/cutting blades/HydroGear filters.
 - (d) Engines – All engines used on Dixon ZTR mowers are warranted by each individual engine manufacturer.
 - (e) Any costs or expense of providing substitute equipment while repair work is being performed on a warranted mower.
7. There is no other express warranty. Implied warranties, including those of merchantability and fitness for a particular purpose, are limited to the same duration of the express warranty, and to the extent permitted by law any and all implied warranties are excluded. Liabilities for consequential damages under any and all warranties are excluded.

Blue/Customer Yellow/Dealer White/Dixon Ind.

WARRANTY VALIDATION: At the time of sale, selling dealer must review each portion of this warranty document, complete the information section below, secure customer's signature & send copy to Dixon Industries, Inc.

DATE OF PURCHASE _____ MODEL _____ S/N _____

Owner's Name _____

Dealership _____

Address _____

Address _____

Owner's Signature _____

Dealer's Signature _____

SPECIFICATIONS

6000 Series Forward Mount

CHASSIS:	Sheet metal construction frame
BODY:	Folded sheet metal. Seat lifts up for access to battery and belt service.
SEAT:	Designed for operator comfort by use of high density closed cell foam padded back and arm rests, upholstered with Cordura™ water-repellent fabric. Seat is adjustable fore and aft.
MOWER DECK:	2 Decks are available. 60" & 48" are made of 12 GA fabricated welded construction with 10 GA reinforcement plate. 3 blades combine for either a 48" or 60" cut width. Cut height approximately 1" to 5" via 9 position lift handle.
BLADE DRIVE:	Electric clutch
DRIVE SYSTEM:	Each rear wheel is independently driven by a HydroGear BDU-10L Series 70 hydrostatic transmission. The hydrostatic transmissions, in turn, power a fully enclosed HydroGear gearbox.
ENGINE:	25HP Kohler Command, 4-Cycle, V-Configuration, Overhead Valve, Air-Cooled, Gasoline, Horizontal Shaft, Aluminum Head, and Crankcase with Cast Iron Liners, Full Pressure Lubrication/Full Flow Filter, Pulse-type Fuel Pump, Fixed Jet Carburetor w/Smart-Choke, Electronic Ignition, In-Line Fuel Filter, Dual Element Air Cleaner.
STARTING SYSTEM:	Electric by key switch operation with safety interlocks on parking brake and blade drive clutch.
TIRES:	Front 4.10x3.50x4 Rear 5.00-6x13 Drive 20-10.0x10
RECOMMENDED TIRE PRESSURE:	Front 16 lbs. Rear 12 lbs.
CAPACITIES:	Fuel - 5 gallons Hydrostat oil tank - 3 quart with in-line 40 micron filter Hydrostat oil recommendation, refer to page 25 Engine - 2 qts. SAE 10W30 (with filter)
DIMENSIONS:	Width 57-1/2"(48" Deck), 69-1/2"(60" Deck) Height 45-1/2" Length 96" (48" Deck), 101" (60" Deck) Weight 960 lbs. (48" Deck), 1030 lbs. (60" Deck)
NOTE:	Additional information provided in service instructions under the individual component.

SPECIFICATIONS SUBJECT TO CHANGE WITHOUT NOTICE

SEAT ADJUSTMENT INSTRUCTIONS

6000 Series

- 1. Grasp seat slide adjuster and move it into adjustment position.**
- 2. Slide seat forward or backward.**
- 3. Release seat slide adjuster.**

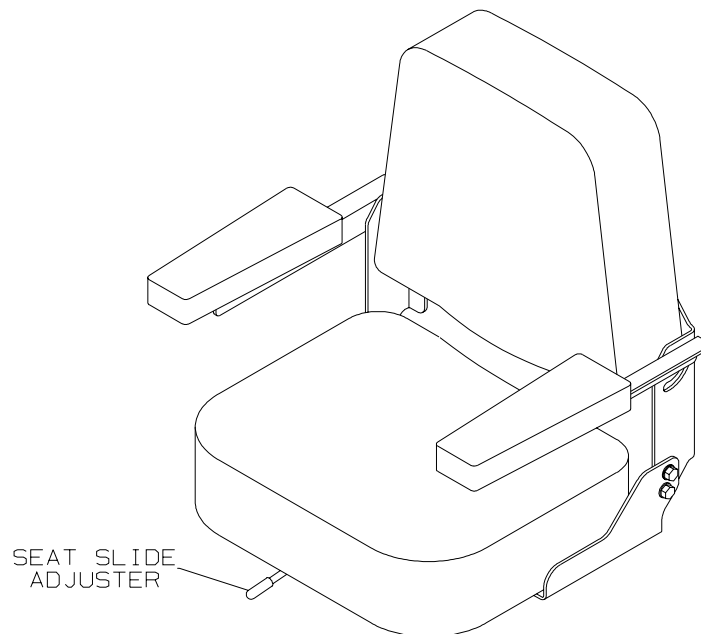

CONTROLS

CONTROL LOCATIONS

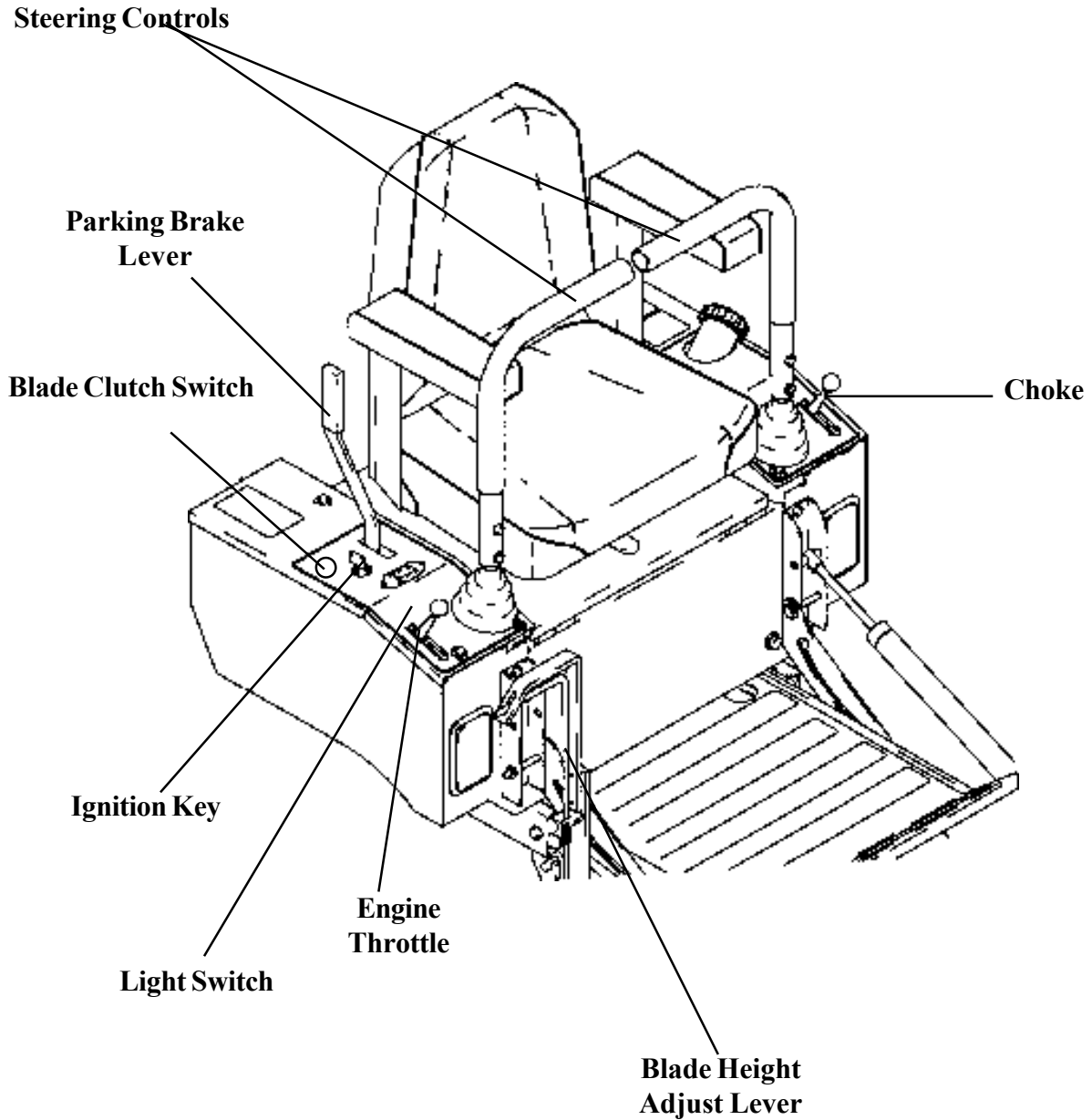

CONTROLS

PARKING BRAKE:

The parking brake is designed to hold the mower from moving and is not intended for use in stopping the mower while it is in motion.



CAUTION Engage parking brake before starting engine

TO SET PARKING BRAKE:

The hand operated parking brake is located at *right* hand side of mower.

To engage brake, pull rearward.

To release brake, move lever forward.

NOTE: *Always set parking brake before dismounting.*

Release parking brake before moving mower.

HYDRO-GEAR DRIVE SYSTEM:

Allows the mower to turn on its own axis (zero turning radius).

Each lever controls one side of the mower.

NOTE: *The pressure required to operate the mower is very light.*

CONTROLS

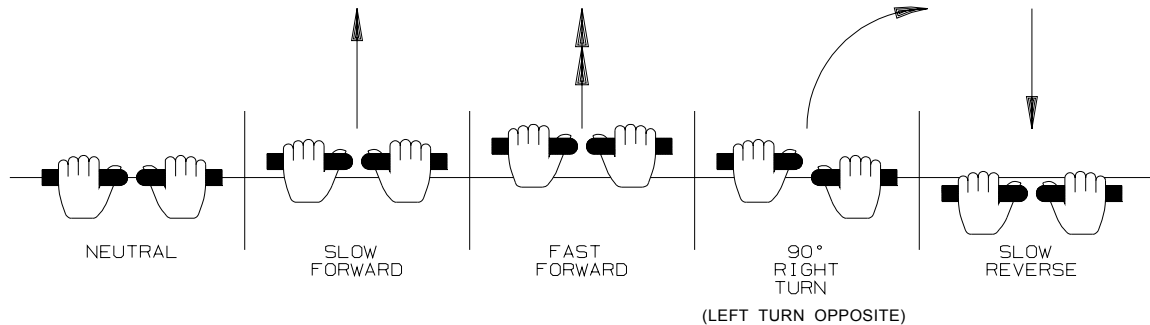

TO GO FORWARD:

From neutral position, gently push both drive levers forward.

To increase speed, move levers farther forward.

TO GO BACKWARD:

From neutral position, gently pull both drive levers toward you.

TURNING:

Turning is controlled by moving one drive lever slightly forward or rearward of the other.

To turn left, move left lever rearward of the right lever.

To turn "square corners" move lever of desired direction to neutral.

To turn on mower's own axis (zero turning radius) stop and move one lever to reverse position and the other to forward position.

BRAKING:

To brake mower, move both levers in direction opposite of travel, release levers to neutral, set parking brake. Park only on level surfaces.

CHOKE CONTROL LEVER:

Located on control panel to operator's left.

Used to start a cold engine.

THROTTLE CONTROL LEVER:

Located on control panel to operator's right.

Controls engine speed, slow to maximum.

While mowing, throttle control should be set to the **MAXIMUM** or wide open setting to insure adequate cooling of the engine and to maintain mower deck blade speed.

CONTROLS

BLADE DRIVE:

Located on the control panel to the operator's right.

To engage blades pull switch up.

To disengage blades push switch down.

CIRCUIT BREAKER:

Located on the control panel to the operator's right.

Protection of the electrical system is by (2) 30 amp circuit breakers.
If circuit breaker trips, push button to reset.
If this condition repeats, consult dealer for inspection and repair.

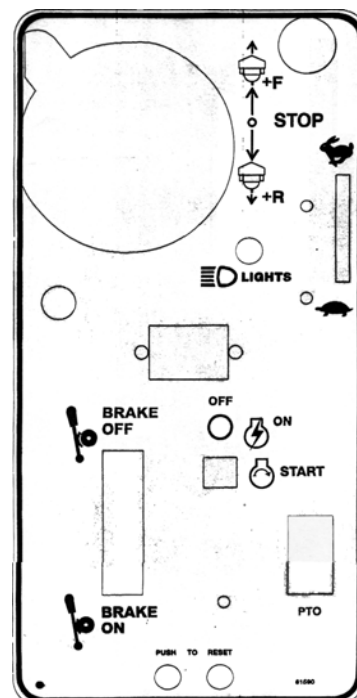

MOWER DECK CUT HEIGHT LIFT LEVER:

Located to the right and front of the operator.

Controls the cutting height.

Nine positions of adjustment.

Depress trigger and move lever forward to lower deck.

Depress trigger and pull lever back to raise deck.

NOTE: To achieve a 1" to 3" cutting range, the bar connecting the deck lift handle and the rear of the deck must be in the first hole. To achieve a 3" to 5" range, the bar connecting the deck lift handle and the rear of the deck must be in the second hole.

NOTE: Always use high position for transport.

OPERATION INSTRUCTIONS

The safe and successful operation of the 6000 Series will depend upon the operator having the correct knowledge of all controls used on the mower and making good judgements about the terrain to be mowed.

NEVER allow anyone to operate the mower without complete knowledge of all controls and their functions.

During initial operation, "learning to drive", set throttle at slow speed.

Sound judgement by the owner will prevent accidents.

TOWING

Towing a trailer or other attachment that is too heavy could damage the drive or cause the mower to become unstable. Limit loads to 500 pounds or less on this mower.

BEFORE OPERATING MOWER

1. Read engine manufacturer's operating and maintenance instructions.
2. Discuss proper maintenance with your dealer.
3. Read and observe all safety instructions on your mower and in the manual.
4. Check engine oil.
5. Check gas cap to be sure it is in place.
6. Be sure parking brake is on.
7. Mower blade drive is off.
8. Know how to stop engine. (Turn key to off position)

OPERATION INSTRUCTIONS

TESTING OF SAFETY INTERLOCK SYSTEMS:

PARKING BRAKE SWITCH TEST: With parking brake in the ON position, start the engine. With the engine running, pull one control lever out of the neutral position. The engine should stop. Repeat for the other control lever, then repeat pulling both control levers out of neutral at the same time. In all cases the engine should stop.

BLADE DRIVE SWITCH TEST: (Electric Clutch or Manual Drive)

- a.  With the electric blade drive switch turned forward, the manual lever turned forward, the engine in On position, engine should not turn over or attempt to start when key switch is moved to the start position.
- b. In a SAFE AREA away from bystanders, start the engine, place throttle setting at maximum or full. Engage the blade drive either through the electric clutch switch or by turning the manual lever forward. Raise weight slightly off of seat. *Engine should stop.*
- c. *If any Safety Check fails, do not operate the mower until the system has been checked and repaired by an Authorized Dixon ZTR Dealer.*

OPERATION INSTRUCTIONS

STARTING INSTRUCTIONS: Cold Engine

1. Push choke control lever fully forward.
2. Push throttle control lever to 1/2 setting.
3. Insert ignition key and turn to "Start" position. When engine starts, release ignition key. Key will return to "Run" position.
4. Once engine starts to *warm up*, slowly move choke control lever to the fully closed position.
5. Move throttle control lever to the *wide open or maximum* setting for actual operation of the mower deck.
6. Engine must be operated at *wide open or maximum* setting to insure adequate lubrication, cooling and cut quality of the mower deck.

Note: 6000 Series mowers will require a slightly longer warm-up period using partial choke settings.

UNLOCK TRANSMISSION:

The freewheel levers are located on each side of the mower below the seat mount (flip up the foot deck to access them). Lift the levers slightly, push them to the rear and down to release the transmissions for free wheeling. To engage the transmissions lift the levers slightly, pull them forward and then down.

NOTE: The tractor should never be pulled at more than 2 miles per hour or for any appreciable distance.

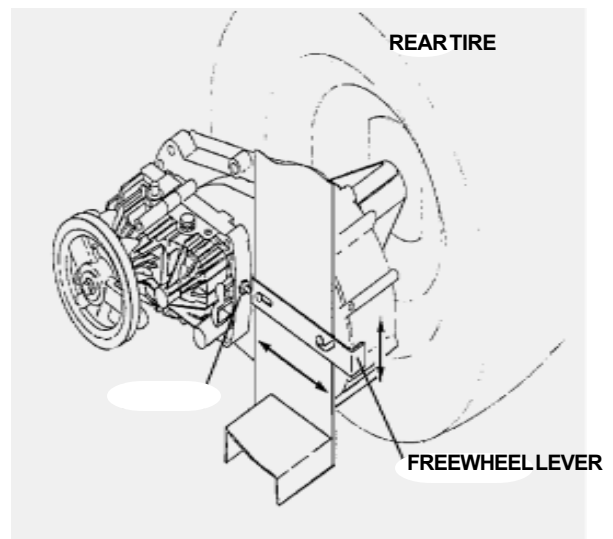

OPERATION INSTRUCTIONS

STARTING INSTRUCTIONS: **Engine has been operated.**

1. Move throttle control lever to 1/4 to 1/2 setting.
2. Insert ignition key and turn to "Start" position. When engine starts, release ignition key. Key will return to "Run" position.
3. Move throttle control lever to *wide open or maximum* setting for actual operation of the mower deck.

NOTE: Model ZTR 6025 may require partial choke setting to start even if the engine has been operated for a period of time.

4. Engine must be operated at *wide open or maximum* setting to insure adequate lubrication, cooling and cut quality of the mower deck.



CAUTION

DO NOT operate the engine in an enclosed area due to the harmful exhaust gas produced.

NOTE: On initial operation, set throttle at slow speed.

Engine cannot be restarted when blade is engaged.

Safety switches stop engine when operator leaves seat while mower blade is engaged.

Always turn engine off when leaving mower.

OPERATION INSTRUCTIONS

In order to achieve optimum cutting performance, please read and follow the tips listed below.

Additional information can be found in the troubleshooting guide on pages 36-37.



CAUTION

Be sure that deflector is properly installed on the discharge chute.

1. Set engine speed control to the wide open or full setting.
2. *Do Not Attempt To Cut Grass When It Is Wet.* Wet grass will clog the underside of the deck and discharge area.
3. If the grass is tall, place the mower deck cut height lever in the top or second notch. "Initially" overlap cutting swaths instead of a full swath with each pass. Some applications may require a second cutting.
4. *Keep The Underside Of The Mower Deck Clean.* Frequent removal of dried grass and dirt will allow the clippings to discharge correctly.
5. *Maintain sharp blade(s) throughout the cutting season.*

GRASS HEIGHT SUGGESTIONS:

Correct mowing height can reduce weeds and disease by 50% to 80%

The following grass cut heights are based on adequate moisture conditions and normal thatch buildup in a healthy lawn. Some locations and applications may require slightly different cut heights. If in doubt, consult your local lawn professional for assistance.

Grass Types:	Best Cut Heights:
Zoysia	2" - 2 1/2"
Blue Grass	1 1/2" - 3"
Fescue Blends	1 1/2" - 3"
St. Augustine (Mid South)	1 1/2" - 2"
St. Augustine (Deep South)	3" - 4"
Tifton Bermuda	1 1/2"
Centipede	1 1/2" - 2"
Common Bermuda	1 1/2" - 2"
Bahia/Argentina/Pensacola	2"

CARE AND MAINTENANCE

CAUTION

Before performing any maintenance, turn off engine, allow to cool, remove key and disconnect spark plugs. Use extreme care when working on machinery. Do not wear watch or jewelry. Do not wear loose fitting clothes, and observe all common safety practices with tools.

MAINTENANCE SCHEDULE

Check drive belts	every 50 hours (20 hours break-in)
Check crankcase oil level.	before each use
Clean grass from Hydrostat fans and cooling fans	before each use
Check air intake screen.	after each use
Clean grass under deck	after each use
Check tire pressure	every 10 hours
Check battery fluid	every 10 hours
Sharpen mower blades	every 10 hours
Check air filter element	every 25 hours
Check hydrostatic transmission fluid	every 25 hours
Service engine air filter pre-cleaner	every 25 hours
Grease driveline (3 fittings)	every 50 hours
Grease jack shaft	every 50 hours
Grease deck pivot tube	every 50 hours
Check adjustment of P.T.O. clutch.	every 50 hours (or if blades do not stop with 7 seconds from switch disengagement)
Service air filter element	every 25 hours
Change engine crankcase oil.	every 100 hours (5 hours break-in)
Change engine oil filter.	every 100 hours
Change hydrostat oil filter (7252)	every 500 hours (50 hours break-in)
Change oil in deck gearbox	annually or every 500 hours
Replace air filter element.	every 100 hours
Check spark plugs.	annually or every 200 hours
Service battery	annually or every 500 hours

Note: *Perform these maintenance procedures more frequently under extremely dusty, dirty conditions. Replace decals when illegible.*

CARE AND MAINTENANCE

ENGINE:

For complete maintenance and operating information of the engine, please refer to the maintenance instructions furnished by the engine manufacturer and included in your Zero Turn Radius Mower information packet.

Note: Air intake screen must be kept clean. If plugged, engine may be seriously damaged by over heating.



CAUTION

Battery electrolyte is a poisonous and corrosive sulfuric acid solution. Avoid spilling on skin, eyes and clothing.

BATTERY:

Check the fluid in the battery at frequent intervals.

Keep fluid level above the plates in each cell, using distilled water.

OFF SEASON BATTERY STORAGE:

Identify each cable so cables can be reconnected to correct terminals.

Disconnect cables from terminals.

ALWAYS disconnect ground cable first and reconnect last.

Charge battery.

DO NOT remove battery from mower.

Clean top of battery and terminals with baking soda and water.

TIRES:

Correct tire pressure is essential for efficient operation of the mower. Check tire pressure periodically. Inflate tires to the pressure listed below.

Front tires - 16 lbs.

Rear tires - 12 lbs.

Lug nuts or lug bolts should be checked regularly for tightness.

CARE AND MAINTENANCE

CAUTION

Stop engine, remove ignition key and spark plugs for safety. Wear heavy, thick gloves when holding onto cutter blade, avoid the sharp edge of the blade.

MOWER BLADES:

Check sharpness of mower blades after every 10 hours of operation. To sharpen blades, proceed as follows.

- A. Remove bolt, lock washer, and large flat washer mounting blade on shaft. Remove blade.
- B. Blades should be discarded when worn excessively.
- C. Sharpen blade with a hand file, electric grinder or blade sharpener. Wear gloves and eye protection when sharpening. Grind blade at original 25 degree bevel.
- D. Check balance of blade by positioning the blade on a nail or blade balance pedestal. Grind the blade on the end that is heavier until both sides balance.
- E. Install blade, flat washer, lock washer and bolt. Make sure to tighten bolt to 60 ft. lbs.

NEW BLADE

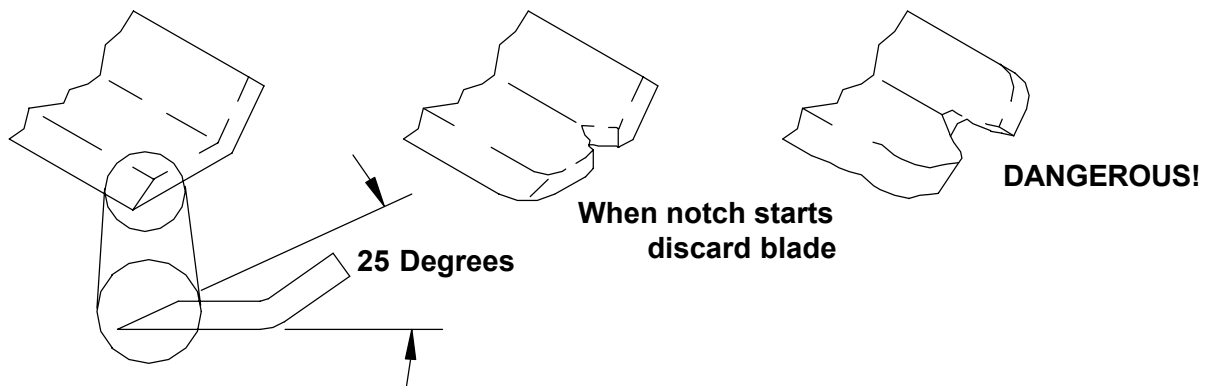

V-BELTS:

The main hydro drive belt should be checked after the first 20 hours and every 50 hours thereafter. Replace any belts found to be in poor condition. The deck belt is equipped with a spring loaded belt tightener and does not require tightening adjustments. The hydrostatic transmission belt is adjusted manually (see page 27 for tensioning instructions).

CARE AND MAINTENANCE

LUBRICATION:

- A. Engine: Follow engine manufacturer's recommendation.
- B. Deck spindles: Lubricate with 3 "shots" only, every 100 hours.
- C. Hydrostatic transmission and filter.
- D. P.T.O. Shaft: Grease every 50 hours.
- E. Deck lift rod wldt: Grease every 50 hours.
- F. Deck Gearbox: See page 32.

CHECKING & REPLENISHING OIL IN HYDROSTATIC TRANSMISSION

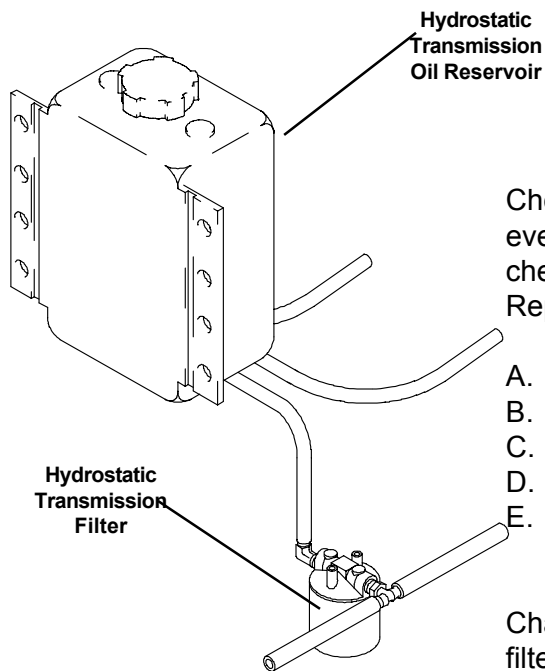

Check the oil level in hydrostatic transmission oil reservoir after every 25 hours of usage. Do not remove the reservoir cap to check the oil level as this allows dirt to enter the transmission. Replenish as needed with 20W-50 Mobil Super H.D.

- A. Wipe area of oil reservoir cap clean of dirt & debris.
- B. Remove oil reservoir cap.
- C. Fill to line marked on reservoir.
- D. Do not overfill.
- E. When check oil level be very careful to keep the reservoir clean and fill only with clean oil.

Change the oil in the reservoir and hydrostat transmission oil filter after the first 200 hours of use. Then every 500 hours after that. Remove the filter and be sure all oil has drained from the reservoir. Replace with new filter and 20W-50 Mobil Super II.

Please dispose of used oil at proper collection centers - protect your environment

CARE AND MAINTENANCE

PARKING BRAKE ADJUSTMENT

With the brake handle in the release position, remove the cotter pin from the castle nut. Insert a 0.010 feeler gauge between the brake disc and the brake puck. Tighten the castle nut with the feeler gauge inserted until the gauge fits snugly between the disc and puck. The gap should not be so tight that the feeler gauge cannot be reinserted after removal. Back the castle nut to the closest pin hole and reinsert the cotter pin. Repeat for other side. See picture at right.

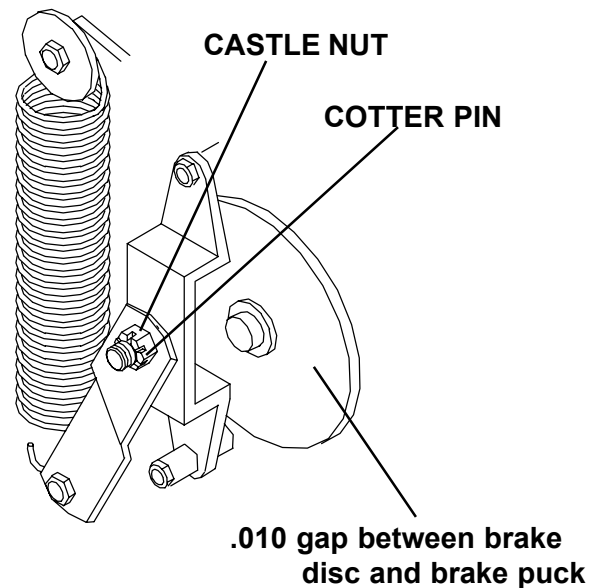

HYDROSTATIC TRANSMISSION:

Before each use, check to be sure that the cooling fins of the hydrostatic transmissions are clean. Excessive accumulation of oil, dirt, or trash may cause the transmission to overheat. NEVER WASH ACROSS TOP OF RESERVOIR with water or steam. Fill reservoir as required per instructions page 25 of this manual.

SCALPER ROLLER BOLTS

Scalper roller bolts should be tightened until the spacer bushing will not turn relative to the scalper bracket to prevent undue wear on the end of the spacer bushing and the scalper bracket. The proper torque is from 17 to 20 ft. lbs.

CARE AND MAINTENANCE

HYDROSTAT DRIVE BELT TENSION ADJUSTMENT

In normal use the hydrostat drive belt tension should be checked after the first 20 hours of use for normal wear in and stretch. It may be adjusted as follows:

- A. Loosen the idler pulley locking nut until the idler pulley can be just moved relative to the mounting bracket.
- B. Tighten the tension adjust bolt until the belt is tight enough to prevent belt slippage. Belt should deflect approximately 3/8" to 5/8" under moderate pressure. Do not over tighten.

NOTE: If belt is over tightened it will often make a "chattering" noise.

- C. Retighten the slide locking nut.

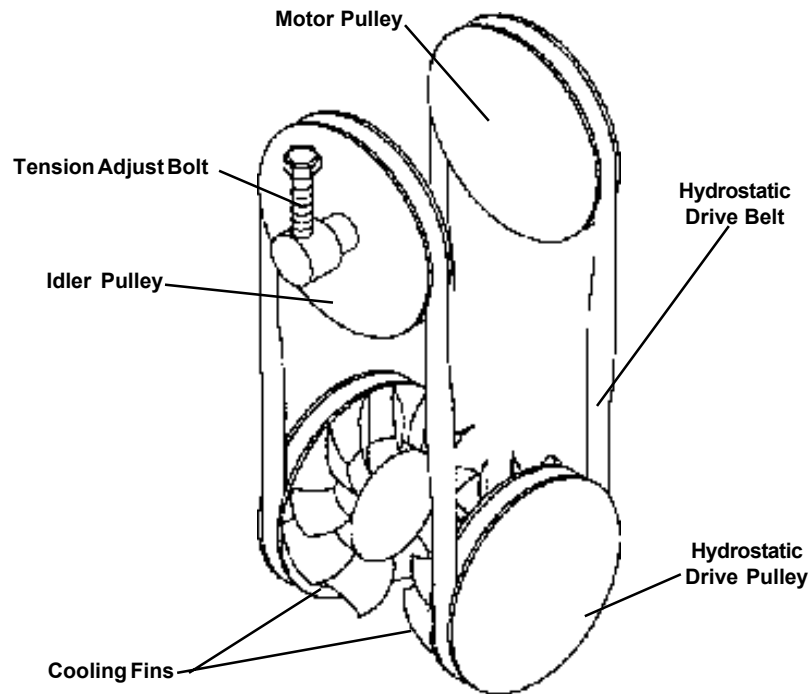

- D. Retighten the tension adjust bolt 1/4 turn to set the lockwasher and prevent loosening of the tension adjust bolt.

CARE AND MAINTENANCE

STEERING CONTROL ADJUSTMENTS

A. To Adjust Neutral:

1. Remove the fender skirts from each side of the machine.
2. Block up the unit so that the Drive Wheels are off the ground.
3. Start the engine and run at a fast idle with the Steering control levers in the "out" position.
4. Loosen the locknuts tightened against the rod end ball joints in the Upper Linkage Assembly.

NOTE: One of these is a left hand nut and will have to be turned backwards.

5. Adjust the Neutral Position by turning the rod in the upper linkage until the wheel stops turning.
6. Retighten the nuts on the Upper Linkage Assembly and check to see that the drive wheel is still not turning.
7. Repeat steps 1-6 for the other side.
8. Shut off engine before removing the blocks.

B. To Adjust "IN" Position of the Steering Controls:

1. Remove the two front bolts, lockwashers, and washers which hold the fender cap.
2. Pull the boot from the hole in the fender cap, exposing the cast iron lever.
3. Using a 5/32" Allen wrench, turn the setscrew to adjust the stop.
4. Replace the boot into the hole in the fender cap.
5. Replace the two front bolts, lockwashers and washers.

C. To Align Handles:

Sit on the seat and push the control levers full forward and full backward. If the ends do not match the handles may be adjusted as follows:

1. Locate setscrew stops in the steering control lever base which stop the lever in each direction.

NOTE: The one at the rear is the stop for FWD and the one in the front is the stop for REV.

2. Adjust setscrew stops so that handles line up together when shifted full forward and full reverse.

CARE AND MAINTENANCE

STEERING CONTROL ADJUSTMENTS (continued):

D. Adjusting for Straight Forward Tracking:

In large open area, actuate the control handles into the full forward position. If the mower veers in either direction (left or right) some adjustment is necessary.

1. If the mower veers to the right, then the right hydrostat needs to be sped up. If the mower veers to the left, then the left hydrostat needs to be sped up.
2. Stop the machine and shut off the engine.
3. Slightly loosen the bolt at the lower end of the upper linkage assembly on the side that is slower. Using a 1/8" allen wrench turn the setscrew 1/4 turn in. It may take several test drives to get the mower to track straight forward.
4. Once the tracking is to the operators liking, completely tighten the bolt on the control linkage, completely tighten the bolt on the control linkage assembly that was loosened earlier.
5. Recheck to make sure neutral adjust has not been effected, see procedure A.

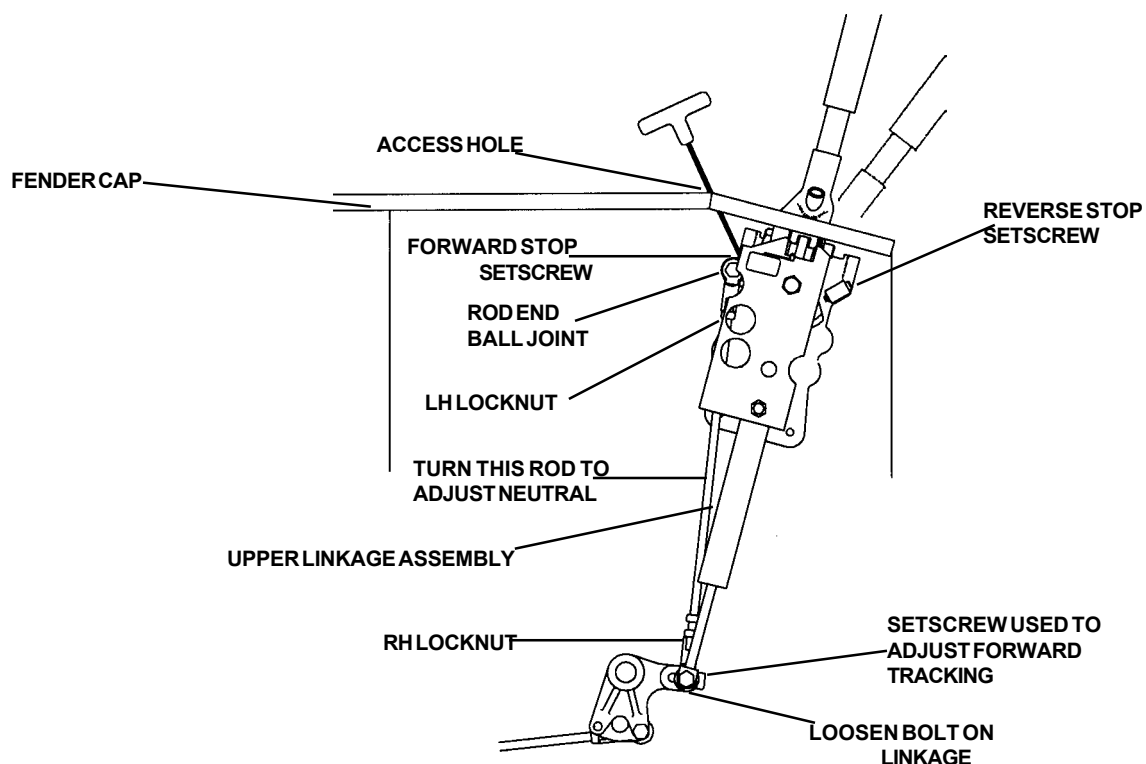

CARE AND MAINTENANCE

TILTING THE DECK (see diagram-page 31)

1. Set the parking brake.
2. Raise the foot deck into vertical position and lock into place.
3. Remove the quick release pin from the anti-buck cylinder at deck end.
4. Place the deck lift handle in the lowest cutting position.
5. Lift the rear corner of deck & pivot down hanger to disengage. (Repeat for other side.)
6. Raise deck lift handle catch, rock handle back and forth until quick release pin pulls free with little effort.
7. Lift up on the front of the deck until deck rotates past 90 degrees. The middle hole on the anti-buck cylinder holder will be in line with the slot on the foot deck locking device. Use the quick release pin to secure the deck in the upright position.

LOWER AND REATTACH THE DECK (see diagram-page 31)

1. Rotate the deck back to horizontal position.
2. Stand on front of deck and align deck lift bar with deck lift handle, rock handle back and forth until quick release pin slips through. NOTE the orientation of the holes in the bar. The first hole is for low cutting 1" to 3", the second hole is for height cutting 3" to 5".
3. Lift the rear corner of the deck until the down hanger engages the push bar. Repeat for other side.
4. Reattach the anti-buck cylinder.
5. Unlatch foot deck locking device and lower the foot deck back to horizontal position.

CARE AND MAINTENANCE

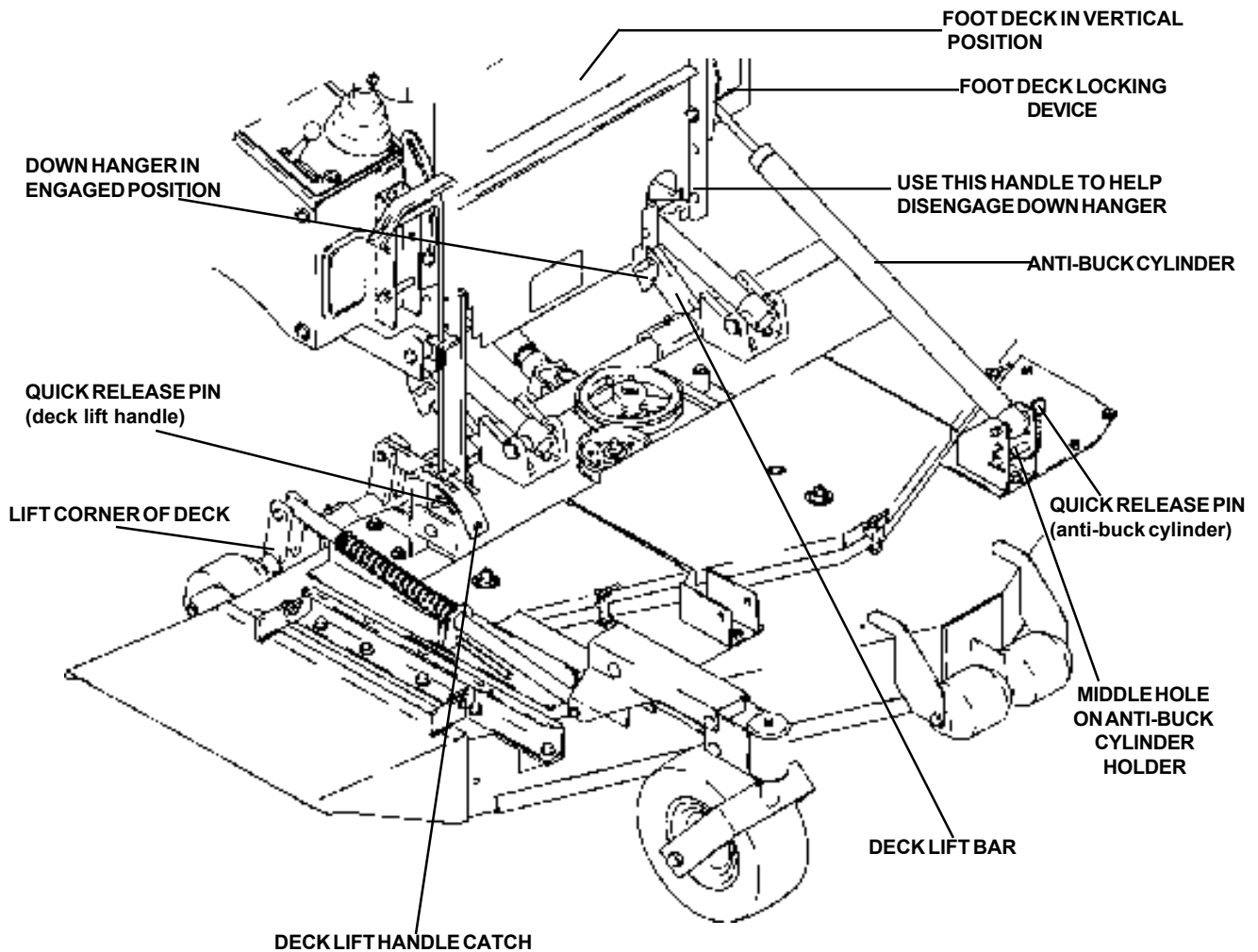

CARE AND MAINTENANCE

CHECKING DECK DRIVE GEARBOX FLUID LEVEL:

The fluid level only needs to be checked if oily residue is found on the gearbox housing.

1. Rotate deck in to the upright position (see deck servicing for procedure).
2. Remove the hex head plug at the low end of the gearbox housing. (Plug closest to the drive shaft.) The fluid level should be level with the bottom of the threaded hole.

CHANGING THE FLUID IN DECK DRIVE GEARBOX:

1. Rotate the deck into the upright position & remove drain plug from bottom of gearbox.
2. Lower deck to drain fluid.
3. When the fluid is drained from gearbox raise deck back up and reinsert the drain plug.
4. Remove hex head plug from side of gearbox and fill with Automatic Transmission Fluid (ATF). Fill to bottom of the hole that the plug is removed from.
5. Reinstall hex head plug.

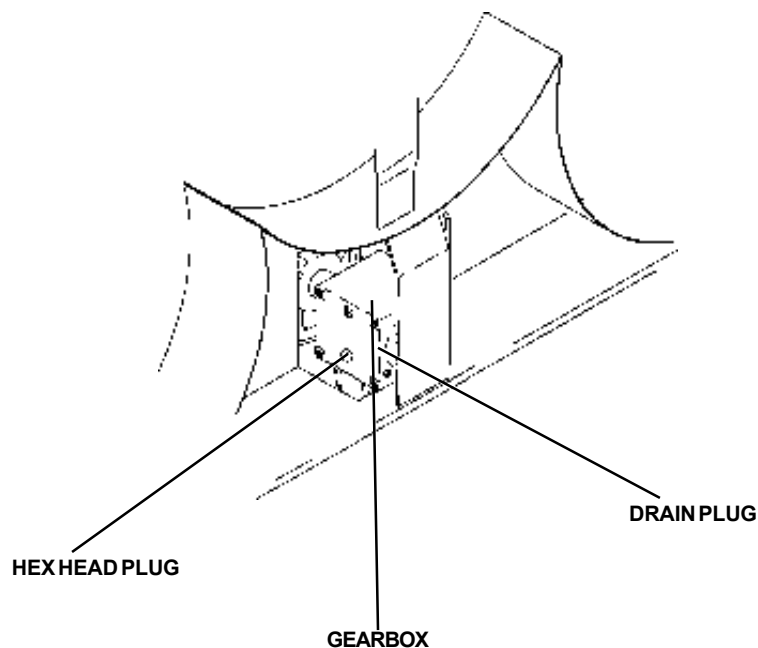

CARE AND MAINTENANCE

LEVELING THE DECK:

The deck comes from the manufacturer pre-leveled. If the deck does appear to be cutting unlevel follow this procedure.

1. Set all tire pressure to correct specifications (see page 23).
2. Place machine on a level slab of concrete.
3. Move blades by hand so all the blades are pointed in the same direction (see diagram on page 34). Measure from the blade tip (beveled edge) to the ground, all three blades. If there is more than a 3/16" difference from one side to the other, the deck should be leveled.
4. Remove the clevis pin from the rear of the lift spring rod, on the high side. The lift spring rod is two parts-one threaded into the other. Turn the lift spring rod counter-clockwise 2 turns. Reassemble clevis pin and remeasure. Repeat as required to achieve a difference of no more than 3/16" from one side to the other.
5. If the deck is level side to side but high or low at the center blade, both lift spring rods must be adjusted equal amounts. Shortening the lift spring rods will bring the center blade up and lengthening the lift spring rods will let the center blade down.

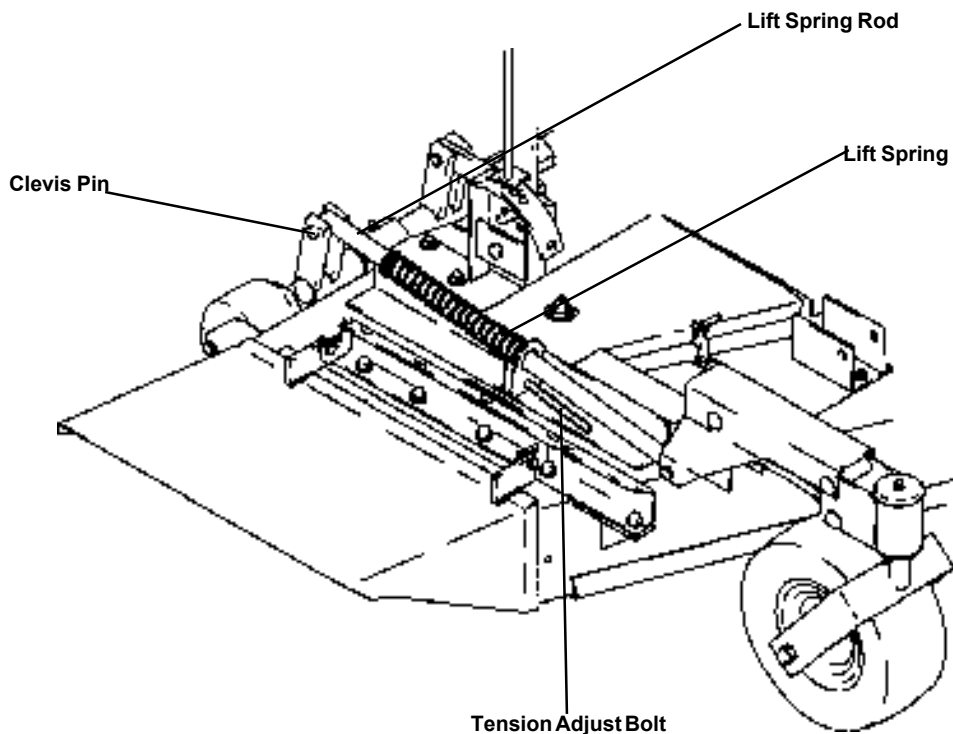

CARE AND MAINTENANCE

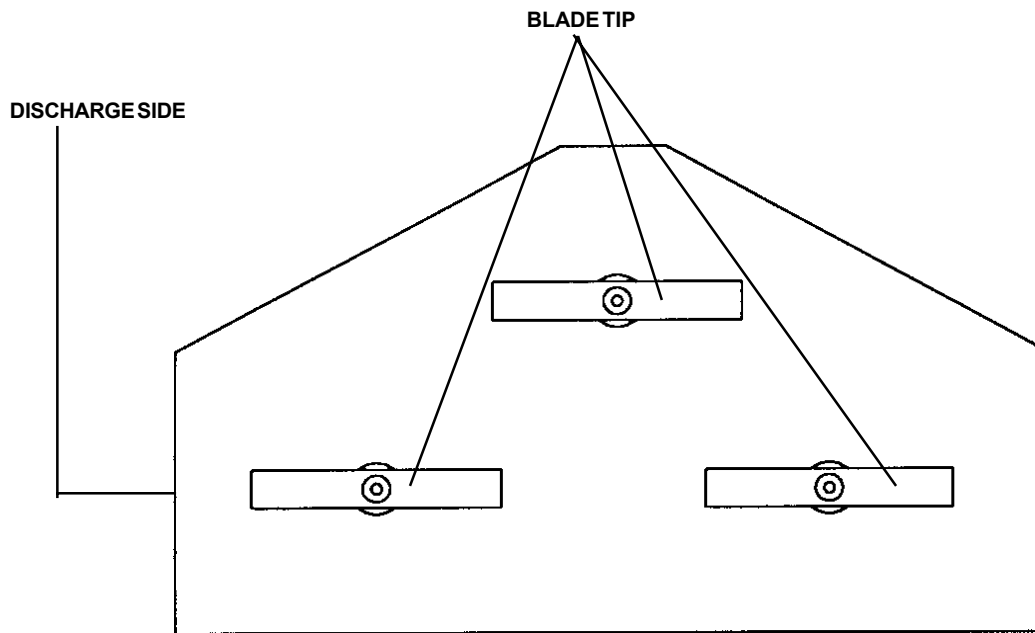

DECK SPINDLE BELT DIAGRAM (Top View)

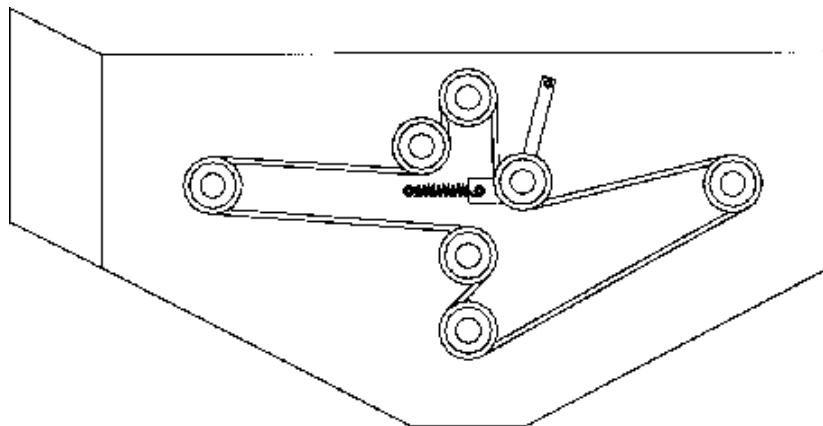

STANDARD SERVICE PARTS LIST

MODEL ZTR 6025:

BLADES:	Hi-Lift:	P/N 60295
	Lo-Lift (standard):	P/N 60293
BELTS:	Serpentine Belt:	P/N 60194 (48") P/N 60186 (60")
	Engine To Hydros:	P/N 61101
	Clutch to Driveshaft:	P/N 60187
Hydrostatic Transmission Filter:		P/N 7252

KOHLER AIR AND OIL FILTER PART NUMBERS:

Refer to engine manufacturers manual for recommendations regarding frequency of service required for engine oil changes and air filter maintenance.

Protect your engine investment, use only original equipment filters.

Model ZTR 6025:	25HP	Air Filter & Pre-Cleaner	78003
		Engine Oil Filter	78006

IMPORTANT:

Some applications, extreme dirt conditions, or the use of a grass catcher may require that the engine used on the Model ZTR 6025 be fitted with an *OPTIONAL Kohler fresh air filter system*.

Listed below are the Kohler kit numbers required to adapt these components to the engine. Consult your dealer or a Kohler engine service center for additional information.

Model ZTR 6025:	25HP	Check with Kohler Dealer for availability
-----------------	------	---

TROUBLESHOOTING

1. ENGINE WON'T TURN OVER

Mower blades engaged-----disengage blades
Drive not in neutral-----move steering control levers to neutral "OUT " position
Blown fuse-----replace fuse
Dead battery-----charge or replace
Solenoid-----consult dealer
Ignition switch-----consult dealer
Starter-----consult dealer

2. ENGINE WILL TURN OVER BUT WON'T START

No gas-----refuel and/or clean or replace fuel filters
Over or under choked-----adjust choke
Spark plug not firing-----check spark plug/condition or reset gap
Carburetor maladjustment-----reset carburetor adjustment/consult dealer
Ignition Switch-----consult dealer for carburetor service

3. HARD TO START ENGINE

Fuel line clogged-----clean fuel line and check fuel filter
Faulty fuel pump-----consult dealer
Spark plug wire loose or grounded-----check spark plug wires
Spark plug(s) faulty or improperly gapped-----check spark plug/condition and reset gap*
Electronic ignition defective-----consult dealer
Dirty or maladjusted carburetor-----readjust carburetor* or consult dealer for carburetor service

4. ENGINE STARTS BUT CUTS OUT

Water in gasoline-----drain old gasoline-replace with new gasoline and/or clean carburetor bowl
Clogged fuel line-----clean carburetor bowl and or check fuel filter
Vent in fuel cap plugged-----check vent
Faulty fuel pump-----consult dealer
Maladjusted carburetor-----readjust carburetor
Engine dies when control levers are moved "IN"-----parking brake set -- release brake

5. ENGINE KNOCKS

Low oil level-----check and add oil
Ignition timing off-----consult dealer
Fuel octane too low-----drain and replace with higher octane gasoline
Over heated engine-----shut off engine and allow to cool

*See engine manual for engine adjustments

TROUBLESHOOTING

6. ENGINE SOMETIMES SKIPS AT HIGHER SPEED

- Incorrect ignition timing-----Consult dealer
- Carburetor maladjusted-----Readjust carburetor
- Faulty spark plugs-----Check spark plug or condition and reset gap*
- Bouncing off seat safety switch-----Slow down on rough terrain

7. ENGINE OVERHEATED

- Air intake screen or fins clogged-----Clean Intake screen and fins
- Fuel mixture too lean-----Consult dealer
- Oil level too low or too high-----Adjust oil level
- Improper ignition timing-----Consult dealer
- Running engine too slow-----Run engine faster

(NOTE: Always mow at full throttle setting.)

8. ENGINE IDLES POORLY

- Carburetor maladjustment-----Consult dealer
- Improper spark plug gap-----Check and re-gap plug*

9. ENGINE BACKFIRES

- Carburetor maladjustment-----Consult dealer*

10. ENGINE RUNS BUT MOWER WON'T MOVE FORWARD

- Drive belt broken or slipping-----Re-tension or replace
- Shift linkage disconnected-----Reconnect
- Transmission shift arm disconnected-----Reconnect
- Transmission oil low-----Add oil
- Transmission locks in free wheel position-----Put in lock position (see pg.19)
- Hydrostat oil filter plugged-----Replace filter
- Bad transmission-----Consult dealer
- Gear mating transmission/gearbox disconnected-----Consult dealer
- Air in transmission-----Bleed air
- Not enough tension on drive belt-----Check

11. MOWER LOSES POWER/ TRANSMISSION OVERHEATS

- Hydrostat transmission oil too low or too high-----Add Oil or drain oil as needed
- Transmission damage-----Consult dealer
- Transmission blowing oil out cap-----Overfilled or water contaminated

12. ENGINE STALLS WHEN BLADES ARE ENGAGED

- Operator not on seat-----Sit on seat
- Faulty interlock system-----Consult dealer
- Bad blade spindle bearing-----Consult dealer
- Deck drive belt not properly routed-----Reroute
- Blades blocked by foreign material-----Clean under deck

*See engine manuals for engine adjustments

NOTES

OWNER INFORMATION



DIXON INDUSTRIES, INC.
ABLOUNT International Inc. Co.
PO BOX 1569
COFFEYVILLE KS 67337 0945
316 251 2000
FAX 316 251 4117



DATE PURCHASED _____

MOWER MODEL NUMBER _____

MOWER SERIAL NUMBER _____

PURCHASED FROM _____

Name

Address

DATE OIL CHANGED:

DATE ENGINE TUNED:



⚠ WARNING: *The Engine Exhaust from this product contains chemicals known to the State of California to cause cancer, birth defects or other reproductive harm.*

Dixon® and ZTR® are registered trademarks of Dixon Industries, Inc.

DIXON INDUSTRIES, INC.
ABLOUNT International Inc. Co.
PO BOX 1569
COFFEYVILLE KS 67337 0945
3162512000

6000 Series
6025
Part No. 13090-0700

Free Manuals Download Website

<http://myh66.com>

<http://usermanuals.us>

<http://www.somanuals.com>

<http://www.4manuals.cc>

<http://www.manual-lib.com>

<http://www.404manual.com>

<http://www.luxmanual.com>

<http://aubethermostatmanual.com>

Golf course search by state

<http://golfingnear.com>

Email search by domain

<http://emailbydomain.com>

Auto manuals search

<http://auto.somanuals.com>

TV manuals search

<http://tv.somanuals.com>