

DIXON[®] ZTR[®]

KODIAK[®] ZTR[®]

and

MOUNTAIN KODIAK[®] ZTR[®]

**Safety Instructions
&
Operator's Manual**

IMPORTANT - READ CAREFULLY

The Dixon® ZTR® mower is both easy and fun to operate. However, any power mower must be operated properly to be safe. It is not a toy or a recreational vehicle. Before you start to use the mower, read this Operator's Manual carefully. It contains valuable information that is necessary for the safe operation of the machine. Observe all safety rules and become completely familiar with the controls.

The information contained in this manual applies to all Dixon® Kodiak® ZTR® mowers.

See your authorized Dixon® dealer for warranty service, parts and repairs or to answer any questions you may have about your new Dixon® ZTR®.

TABLE OF CONTENTS

	<u>Page</u>
SAFETY & WARNING.....	4-15
WARRANTY.....	16
SPECIFICATIONS.....	17
SEAT ADJUSTMENT.....	18
CONTROLS.....	19-21
OPERATION INSTRUCTIONS.....	22-32
CARE & MAINTENANCE.....	33-47
TROUBLESHOOTING.....	48-49
STANDARD SERVICE PARTS LIST.....	50

KODIAK®
Part Number 18124-106

SAFETY

**⚠ RIDING LAWN MOWERS,
IF IMPROPERLY OPERATED
CAN CAUSE SERIOUS INJURY OR DEATH**

Pictured below are the most common causes of injury to the operator or bystander. Please read and understand this manual to prevent injuries.

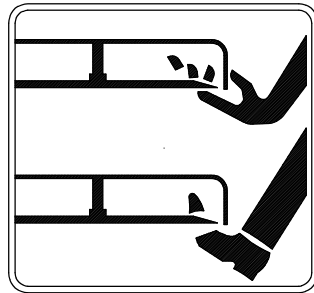

Blade Contact



Tip Over

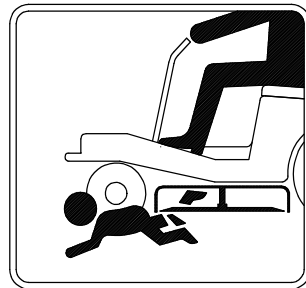

Run Over



Back Over

SAFETY



Safety Alert Symbol

When you see this symbol, BE ALERT to the potential for injury.

Follow the recommended safety precautions and safe operating practices.



DANGER
(highlighted in red)
indicates an imminently hazardous situation which, if not avoided, will result in death or serious injury.



WARNING
(highlighted in orange)
indicates a potentially hazardous situation which, if not avoided, could result in death or serious injury.



CAUTION
(highlighted in yellow)
indicates a potentially hazardous situation which, if not avoided, may result in minor or moderate injury. It may also be used to alert against unsafe practices.

WARNING

 ***Failure to observe the following safety instructions could result in serious injury or death.***

GENERAL OPERATION:

Read, understand, and follow all instructions in this manual and on the mower before starting.

Only allow responsible adults, who are familiar with the instructions, to operate the mower.

Clear the area of objects such as rocks, toys, wire, etc., which could be picked up and thrown by the blade.

Be sure the area is clear of other people before mowing. Stop mower if anyone enters the area.

Be aware of the mower discharge direction and do not point it at anyone. Mower blades can throw rocks or other debris.

Do not operate the mower without either the entire grass catcher or the deflector in place. This will decrease the possibility of injury from objects being thrown by the mower blades.

Never carry passengers. They may fall off and become seriously injured or interfere with safe operation of the mower.

Mowing in reverse is not recommended because it is difficult to maintain a clear vision of the mowing path. However, should it become necessary to back up, remember to look down and behind before and while backing.

WARNING

 **Failure to observe the following safety instructions could result in serious injury or death.**

GENERAL OPERATION (continued):

Never leave a running mower unattended. Always turn off blades, set parking brake, stop engine and remove key before dismounting.

Turn off blades when not mowing. Injury could occur from contact with moving parts.

Under no circumstances should you place hands or feet under the mower deck or in the chute while blades or impeller are still running.

To avoid personal injury from accidental clutch engagement, stop engine before removing grass catcher or unclogging chute.

Mow only in daylight or good artificial light.

Do not operate the mower while under the influence of alcohol or drugs.

Slow down before turning to reduce the risk of tip-over.

Watch for traffic when operating near or crossing roadways.

Use extra care when loading or unloading the mower into a trailer or truck. Push, do not ride the mower when loading and unloading.

WARNING

 **Failure to observe the following safety instructions could result in serious injury or death.**

GENERAL OPERATION (continued):

Never dismount mower without applying parking brake or stopping engine.

Protect your eyes. Always wear safety goggles or safety glasses with side shields when operating mower.

Data indicates that operators, age 60 years and above, are involved in a large percentage of riding mower-related injuries. These operators should evaluate their ability to operate the riding mower safely enough to protect themselves and others from serious injury.

To protect against possible tip-over, follow the manufacturer's recommendation for wheel weights, counterweights and R.O.P.S.

Maintain or replace safety & instruction labels as needed.

The engine exhaust from this product contains chemicals known to the State of California to cause cancer, birth defects or other reproductive harm.

WARNING

 **Failure to observe the following safety instructions could result in serious injury or death.**

SLOPE OPERATION:

Slopes are a major factor related to loss-of-control and tip-over accidents, which can result in severe injury or death.

All slopes require extra caution. If you feel uneasy on a slope, do not mow it!

DO

Mow across the slope with your Dixon® ZTR® -- never up or down. This will decrease the risk of tip-over.

Remove obstacles such as rocks, tree limbs, wires and other foreign objects that can be thrown by mower blades.

Watch for holes, ruts, roots and bumps. Uneven terrain could overturn the mower. Tall grass can hide such obstacles.

Use slow speed. Tires may lose traction on slopes even though the brakes are functioning properly.

Avoid starting or stopping on a slope. If tires lose traction, disengage the blades and proceed slowly down the slope.

WARNING

 **Failure to observe the following safety instructions could result in serious injury or death.**

SLOPE OPERATION (continued):

DO (continued):

Keep all movement on the slopes slow and gradual. Do not make sudden changes in speed or direction.

Use extreme caution when operating the mower with attachments to prevent tip-over or roll-over.

If front wheels lift off the ground, pull levers back to stabilize the mower. Discontinue mowing the slope!

When operating on slopes over 15 degrees, the unit must be equipped with an approved, dealer-installed R.O.P.S. and Seat Belt Kit.

R.O.P.S. should be in the upright, operating position (not folded-down) at all times when operating mower.

Always use seat belt on any mower equipped with a R.O.P.S.

WARNING

 **Failure to observe the following safety instructions could result in serious injury or death.**

SLOPE OPERATION (continued):

DO NOT

Do not turn on slopes unless necessary, and then, turn slowly and gradually downhill, if possible. Rapid uphill turns may cause tip-over.

Do not mow near drop-offs, ditches, or embankments. The mower could suddenly turn over if a wheel is over the edge of a cliff or ditch or if an edge caves in.

Do not mow on wet grass. Reduced traction could cause sliding.

Do not try to stabilize the mower by putting your foot on the ground.

Do not use grass catcher or other attachments on steep slopes (over 15 degrees). The added weight may change the stability of the mower thus creating the potential for tip-over.

WARNING

 ***Failure to observe the following safety instructions could result in serious injury or death.***

FIRE HAZARDS:

Use extra care when handling gasoline and other fuels. They are flammable and vapors are explosive.

Store all fuel in approved containers specifically designed for that purpose.

Allow engine to cool before refueling. Never remove fuel cap or add fuel with engine running.

Do not smoke while refueling or operating the mower.

To reduce fire hazard, keep mower free of grass, leaves and other debris build-up.

If gasoline is spilled, do not attempt to start the engine. Move mower away from the area of the spill. Do not create any source of ignition until gas vapors have dissipated. Wipe up spilled fuel and dispose of waste properly.

If fuel is spilled on clothing, change clothing immediately.

Before storing, allow mower to cool. Clean fuel and oil spillage.

Never store the mower or fuel container inside a building where there is an open flame.

WARNING

 **Failure to observe the following safety instructions could result in serious injury or death.**

FIRE HAZARDS (continued):

To prevent fire or explosion, keep sparks and open flames away from battery.

Keep electrical connections clean and tight. Inspect them often. Loose connections and corrosion increase fire risk.

Before disconnecting the negative ground cable, make sure all switches are off. This decreases the chance of sparking and fire.

Use care when backing to avoid pushing the grass bags into the frame or “hot” exhaust muffler of the engine. Fire could result.

To prevent fire and explosion caused by static electricity:

Never fill containers inside a vehicle or on a truck or trailer bed with a plastic liner. Always place containers on the ground away from your vehicle before filling.

When practical, remove fuel powered equipment from the truck or trailer and refuel it on the ground. If this is not possible, refuel such equipment on a trailer with a portable container, rather than from a fuel dispenser nozzle.

If a fuel dispenser nozzle must be used, keep the nozzle in contact with the rim of the fuel tank or container opening at all times until fueling is complete. Do not use a nozzle lock-open device.

WARNING

 **Failure to observe the following safety instructions could result in serious injury or death.**

CHILDREN:

Tragic accidents can occur if the operator is not alert to the presence of children.

Children are attracted to lawn mowers and the mowing activity.

NEVER assume children will stay where they were last seen.

Be alert to avoid accidents.

Keep children out of the mowing area and under the watchful care of another responsible adult.

Be alert and turn mower off if a child enters the area.

Before and during backing look BEHIND and DOWN for small children.

Never carry children. They may fall off and be seriously injured or interfere with safe mower operation.

Never allow children to operate the mower.

Use extra care when approaching blind corners, shrubs, trees, or other objects that may obscure vision.

WARNING

 ***Failure to observe the following safety instructions could result in serious injury or death.***

SERVICE:

Never run a mower inside a closed area or without proper ventilation.

Keep nuts and bolts tight, especially blade attachment bolts, and keep equipment in good condition.

Never tamper with safety devices. Check their proper operation regularly.

Stop and inspect the equipment if you strike an object. Repair, if necessary, before restarting.

Never make adjustments or repairs with the engine running unless otherwise specified.

Grass catcher components are subject to wear, damage and deterioration which could expose moving parts or allow objects to be thrown. Frequently check components. Replace with original equipment parts when necessary.

Mower blades are sharp and can cut. Wrap blades or wear gloves, and use extra caution when servicing them.

Batteries contain sulfuric acid. To prevent burns, avoid contact with skin, eyes and clothing.

DIXON® ZTR® PRO SERIES COMMERCIAL/RESIDENTIAL WARRANTY POLICY
Black Bear™, Kodiak®, Mountain Kodiak®, Kodiak® Diesel, Grizzly™ & SilverTip™ Mowers

DIXON® WARRANTS ITS ZTR® MOWERS AGAINST DEFECTS IN MATERIAL AND WORKMANSHIP FOR THE PERIODS SET FORTH BELOW. THE SOLE REMEDY UNDER THIS WARRANTY IS REPLACEMENT OR REPAIR OF PARTS INCLUDING LABOR COSTS.

THIS WARRANTY IS SUBJECT TO THE FOLLOWING CONDITIONS AND LIMITATIONS:

1. COMMERCIAL WARRANTY (use other than, or in addition to, mowing at owner's primary place of residence):
 - a. First two years - 100% parts and labor subject to the conditions and limitations described herein with the exception of non-covered items specified below.
 - b. Third year - limited to 100% parts cost as shown in the current Dixon® Parts Price List and subject to the conditions and limitations as described herein.
 - c. Attachments marketed through or approved by Dixon Industries, Inc. are warranted for one year parts and labor in commercial use applications.
 - d. Pro Series Models are not subject to hour meter restrictions.
 - e. Warranty applies to new and unused mowers and ***is transferable***.
2. RESIDENTIAL WARRANTY (used only at owner's primary place of residence):
 - a. Three years - 100% parts and labor subject to the conditions and limitations described herein for a period of three years from date of purchase by the original owner.
 - b. Attachments marketed through or approved by Dixon Industries, Inc., are warranted for two years parts and labor in residential use applications.
 - c. Warranty applies to new and unused mowers and ***is transferable***.
3. Lifetime warranty on all frames and leading edge of all fabricated (welded) decks.
4. All Dixon® warranty must be accomplished by authorized Dixon® dealers and in accordance with Dixon® warranty policy and allowances. All warranty claims must be submitted to Dixon Industries for approval.
5. Warranty labor reimbursement to dealers based on published Dixon® flat rate schedule.
6. Warranty does not apply to damage in transit or incidents of misuse, negligence, accidents, or alteration. The use of parts or components other than those supplied by Dixon Industries VOIDS ALL WARRANTY.
7. Battery warranty is limited to one year from date of manufacture.
8. The following items are not covered by this warranty policy:
 - (a) Routine maintenance or adjustments to include any oils, filters or other fluids used.
 - (b) Belts, blades, tires and cosmetic appearance (paint, seat fade, etc.)
 - (c) Pick up and delivery charges for transportation of mower to and from an authorized Dixon® dealer's place of business.
 - (d) Engines. These are covered under a separate warranty by each individual engine manufacturer. Consult engine manual for warranty details.
 - (e) Any costs or expense of providing substitute equipment while repair work is being performed on a warranted mower.
9. THERE IS NO OTHER EXPRESS WARRANTY. TO THE EXTENT PERMITTED BY LAW, ALL IMPLIED WARRANTIES, INCLUDING THOSE OF MERCHANTABILITY AND FITNESS FOR A PARTICULAR PURPOSE ARE EXCLUDED; OTHERWISE, ALL SUCH IMPLIED WARRANTIES ARE LIMITED TO THE SAME DURATION AND REMEDIES AS THE EXPRESS WARRANTY. ALL LIABILITIES FOR CONSEQUENTIAL DAMAGES UNDER ANY EXPRESS OR IMPLIED WARRANTY ARE EXCLUDED.

SPECIFICATIONS

KODIAK® and MOUNTAIN KODIAK®

CHASSIS:	11 GA - rectangular tube
SEAT:	Designed for operator comfort by use of high-density closed cell foam padded back and arm rests, upholstered with Cordura™ water-repellent fabric. Seat is adjustable fore and aft. Mounted on operator suspension system.
MOWER DECK:	Made of 11 GA fabricated welded construction with external reinforcement ribs. Three blades combine for a 50" cut width. Cut height approximately 1.5" to 5" via 12 position lift handle.
BLADE DRIVE:	Electric clutch
DRIVE SYSTEM:	Each rear wheel is independently driven by a Parker 10cc pump or 10cc pump with fan (Mountain Kodiak only) and TE0230 wheel motor.
ENGINE:	Each mower is powered with either a 19HP Kawasaki, 20HP Honda, 20HP Kohler, 21 HP Briggs & Stratton Vanguard, or a 25HP Kohler (Mountain Kodiak only) twin cylinder engine, overhead valve, air cooled, gasoline, full pressure lubrication with oil filter.
STARTING SYSTEM:	Electric by key switch operation with safety interlocks on parking brake and blade drive clutch.
TIRES:	Front 13 x 5 x 6 smooth tread (16-21 lbs) Rear 20 X 10 X 10 Turf Master (8-14 lbs)
CAPACITIES:	Fuel - 11 gallon (approximately) Hydrostat Oil tank - 4 quart with in-line 25 micron filter Engine - 2 qts. SAE 10W30 (with filter)
DIMENSIONS: (approximate)	Width 46" outside rear wheel measurement Height 46.5" Length 75" Weight 760 lbs.

Additional information may be provided elsewhere in this manual.

SPECIFICATIONS SUBJECT TO CHANGE WITHOUT NOTICE

SEAT ADJUSTMENT INSTRUCTIONS

1. Grasp seat slide adjuster and move it into adjustment position.
2. Slide seat forward or backward.
3. Release seat slide adjuster.

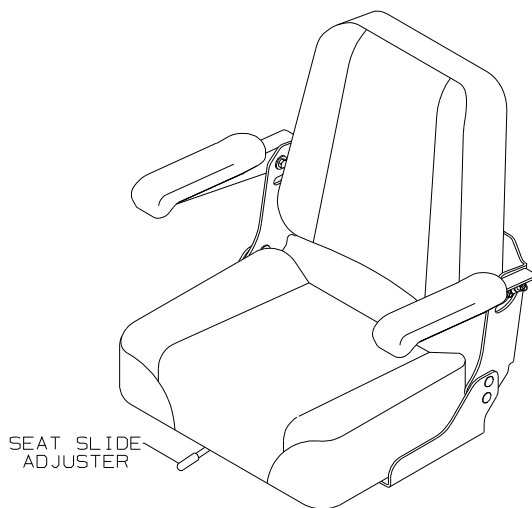

CONTROLS

CONTROL LEVERS

Note: For access to the seat, move control levers to neutral position and swing them outward.

TO GO FORWARD

- From neutral position, gently push control levers forward.
- To increase speed, move levers further forward.

TO GO BACKWARDS

- From neutral position, gently pull control levers toward you.

TURNING

- Turning is controlled by moving one control lever slightly forward or rearward of the other.
- To turn left, move left lever rearward of the right lever.
- To turn right, move right lever rearward of the left lever.
- To turn on mower's own axis (zero turning radius), stop and move one lever to reverse position and the other to forward position.

BRAKING

- To brake mower, move both levers in direction opposite of travel.

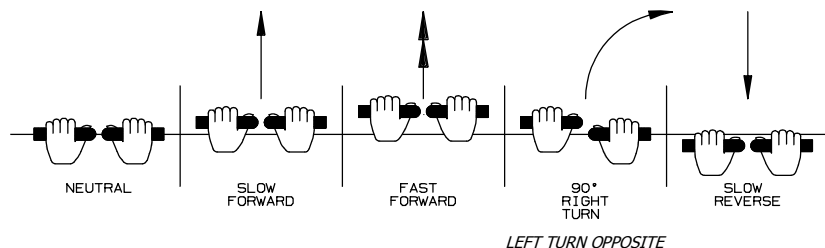

Note: The pressure required to operate the mower is very light.

CONTROLS

PARKING BRAKE:

The parking brake is designed to hold the mower from moving and is not intended for use in stopping the mower while it is in motion. The engine will stop if the parking brake is engaged while the control levers are in the drive position.

⚠ CAUTION Engage parking brake before starting engine.



TO SET PARKING BRAKE:

The hand operated parking brake is located on the left hand side of the mower.

- To engage brake, pull lever up (to the rear).
- To release brake, move lever forward (down).

Note: Always set parking brake before dismounting.
Release parking brake before moving mower.

MOWER DECK CUT HEIGHT LIFT LEVER:

- Located to the right and front of the operator.
- Controls the cutting height.
- Eight positions of adjustment
- Depress trigger and move lever forward to lower deck.
- Depress trigger and pull lever back to raise deck.

Note: Always use high position for transport.

CONTROLS

BLADE DRIVE:

- Located on the control panel, on operator's right.
- To engage the mower blade, pull up on the switch.
- To disengage mower blade, push down.

CIRCUIT BREAKER:

- Located on the control panel to the operator's right.
- Protection of the electrical system is by (1) 15 amp circuit breaker.
- If circuit breaker trips, push button to reset.
- If this condition repeats, consult dealer for inspection and repair.

CHOKE AND THROTTLE CONTROL LEVERS:

- Located on control panel to operator's right.
- Throttle control for engine speed.
- Choke for engine starting.
- Throttle control should be set to MAXIMUM or wide open setting to insure adequate cooling of the engine and to maintain mower deck blade speed while mowing.

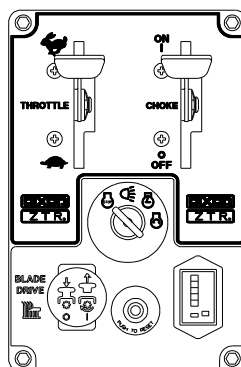

OPERATION INSTRUCTIONS

The safe and successful operation of the KODIAK™ will depend upon the operator having the correct knowledge of all controls used on the mower and making good judgements about the terrain to be mowed.

NEVER allow anyone to operate the mower without complete knowledge of all controls and their functions.

NEVER dismount mower without applying parking brake or stopping engine.

During initial operation, “learning to drive”, set throttle at slow speed.

Sound judgement by the operator will prevent accidents.

BEFORE OPERATING MOWER:

1. Read engine manufacturer’s operating and maintenance instructions.
2. Read and observe all safety instructions on your mower and in the manual.
3. Check engine oil.
4. Check fuel cap to be sure it is in place.
5. Be sure parking brake is on.
6. Be sure mower blade drive is off.
7. Know how to stop engine. (Turn key to off position).

OPERATION INSTRUCTIONS



CAUTION Failure to follow these instructions may result in personal injury.

STARTING INSTRUCTIONS:

1. Parking brake must be on, control levers in outward position and blade drive disengaged.
2. Position throttle to 1/2 speed setting. If engine is cold, position choke lever to the "on" position.

NOTE: Engine may require partial choke setting to start even if the engine has been operated for a period of time.

3. Insert ignition key and turn to "start" position. When engine starts, release ignition key. Key will return to "run" position.
4. Return choke to "off" position, if applicable.
5. Move "throttle" to maximum speed position.
6. Release parking brake.
7. Swing levers inward.
8. Operate mower per "CONTROL" instructions on Page 19.



CAUTION Do not operate the engine in an enclosed area due to the harmful exhaust gas produced.

Note: Engage blade drive with throttle in the mid-range position. When mowing (blades engaged), set throttle control to the MAXIMUM or wide open setting to ensure adequate cooling of the engine and to maintain mower deck blade speed.

OPERATION INSTRUCTIONS

TESTING OF SAFETY INTERLOCK SYSTEMS:



Failure to observe the following testing instructions could result in serious injury or death.

The following tests should be performed at the start of each mowing day.

PARKING BRAKE SWITCH TEST:

- a) Swing control levers to outward position
- b) Disengage blade drive switch
- c) Put parking brake in OFF position
- d) Turn ignition switch to START

Engine should not turn over or attempt to start.

CONTROL LEVER SWITCH TEST:

- a) Disengage blade drive switch
- b) Put parking brake in ON position
- c) Swing control levers inward
- d) Turn ignition switch to START

Engine should not turn over or attempt to start.

NOTE: If any safety check fails, do not operate the mower until the system has been checked and repaired by an Authorized Dixon® Dealer.

OPERATION INSTRUCTIONS

TESTING OF SAFETY INTERLOCK SYSTEMS:



Failure to observe the following testing instructions could result in serious injury or death.

The following tests should be performed at the start of each mowing day.

BLADE DRIVE SWITCH TEST:

- a) Put parking brake in ON position.
- b) Swing control levers to outward position.
- c) Engage blade drive switch.
- d) Turn ignition switch to START.

Engine should not turn over or attempt to start.

SEAT SWITCH TEST:

- a) In a SAFE AREA away from bystanders, start the engine.
- b) Leave control levers in outward position and put parking brake ON position.
- c) Engage blade drive.
- d) Raise slightly off seat.

ENGINE SHOULD STOP!

NOTE: If any safety check fails, do not operate the mower until the system has been checked and repaired by an Authorized Dixon® Dealer.

OPERATION INSTRUCTIONS

MOWING WITH A MULCHING ATTACHMENT:

Mulching or recycling the grass clippings requires a totally different mowing approach than would be normal when side discharging or bagging the grass. There may be instances or conditions where it is not possible to hide all the recycled or mulched clippings.

In order to achieve the best results, please read and follow the mulching tips listed below:

1. Read and follow the installation instructions that are included with your mulcher.
2. Set the engine speed control to the wide open or full setting.
3. Place the mower deck cut height selector in either the top or second notch. Never cut more than 3/4" to 1" off the grass at any one time. Attempting to cut more grass will result in the deck plugging and cause the engine to stall.
4. It may be necessary to cut the lawn twice to achieve acceptable mulching performance especially on first cuttings or if the lawn is heavily fertilized.
5. *Do not attempt to cut grass when it is wet.* Mulching performance will be very poor in wet grass conditions.
6. *Maintain sharp blades throughout the cutting season.* This is very important. Optimal mulching performance cannot be obtained with a dull or nicked up blade.

OPERATION INSTRUCTIONS

MOWING WITH A MULCHING ATTACHMENT (continued):

7. *Keep the underside of the mower deck clean.*
Remove all grass and dirt build-up from the underside of the pan, the baffles and deflectors after each use. **Never, under any circumstances, should you place hands or feet under the mower deck or in the chute while blades or impeller are still turning.**

8. Alternate mower direction. This will evenly disperse the mulched grass clippings over the lawn for even fertilization.

If the mulching quality of the mower does not seem to be satisfactory, try one or more of the following tips:

- a. Raise the height-of-cut setting on your mower.

- b. It may be necessary to cut your grass more frequently.

- c. Operate the mower at a slower ground speed.

- d. Overlap cutting swaths instead of cutting a full swath with each pass.

- e. Mow across the marginal areas a second time.

- f. CUT HIGH - MOW OFTEN!

OPERATION INSTRUCTIONS

MOWING WITH A GRASS CATCHER ATTACHMENT:

In order to achieve optimum performance when mowing with a grass catching attachment, please read and follow the tips listed below.

1. Read and follow the installation instructions that are included with your grass catcher.
2. Set engine speed control to the wide open or full setting.
3. *Do not attempt to cut grass when it is wet.* Wet grass will clog both the underside of the deck and the attachment chutes. Empty bags often to prevent plugging.
4. If the grass is tall, place the mower deck cut height selector in the top or second notch. "Initially" overlap cutting swaths instead of a full swath with each pass.
5. *Keep the underside of the mower deck clean.* Frequent removal of dried grass and dirt will greatly assist in bagging of the clippings. **Never, under any circumstances, should you place hands or feet under the mower deck or in the chute while blades or impeller are still turning.**
6. Operate the mower at a slower ground speed than when mowing without a grass catching attachment.

OPERATION INSTRUCTIONS

MOWING WITH A GRASS CATCHER ATTACHMENT (continued):

7. *Maintain sharp blades throughout the cutting season.* Some grass catching attachments require a “high-lift” blade. See your dealer for advice on the type of blade(s) needed for your mower.
8. Some mowing applications/use of grass catchers may require that an additional weight kit be fitted to the mower to counter the weight of grass in the bags. Please consult with your dealer for more information regarding installation and adding weight to the box.



WARNING Failure to observe the following instructions may result in personal injury.

- Watch for low hanging branches or other obstacles which might hit the catcher top while turning or backing the mower.
- Use care when backing to avoid pushing the grass bags into the frame or “hot” exhaust muffler of the engine. Fire could result.
- Disengage blade and stop engine prior to clearing grass from either the discharge chute or grass catcher components.
- Do not operate the mower with the grass catching attachment partially removed. Operator or bystanders could be injured by thrown objects.
- Keep all attachment bolts tight.
- *Important: Do Not leave clippings in the bags while the mower is stored.* Damp grass clippings are a fire hazard if left in the bag.

OPERATION INSTRUCTIONS

SIDE DISCHARGE OF THE CLIPPINGS:

In order to achieve optimum performance when side discharging the grass clippings, please read and follow the tips listed below. Additional information can be found in the Troubleshooting guide.



CAUTION To avoid personal injury, be sure that the deflector is properly installed on the discharge chute.

1. Set engine speed control to the wide open or full setting.
2. *Do not attempt to cut grass when it is wet.* Wet grass will clog the underside of the deck and discharge area.
3. If the grass is tall, place the mower deck cut height lever in the top or second notch. “Initially” overlap cutting swaths instead of a full swath with each pass. Some applications may require a second cutting.
4. *Keep the underside of the mower deck clean.* Frequent removal of dried grass and dirt will allow the clippings to discharge correctly. **Never, under any circumstances, should you place hands or feet under the mower deck or in the chute while blades or impeller are still turning.**
5. *Maintain sharp blade(s) throughout the cutting season.*

OPERATION INSTRUCTIONS

GRASS HEIGHT & CUTTING SUGGESTIONS:

Do not attempt to cut grass when it is wet.

If the grass is tall, place the mower deck cut height lever in the top or second notch. "Initially" overlap cutting swaths instead of a full swath with each pass. Some applications may require a second cutting.

Keep the underside of the mower deck clean.

Maintain sharp blades throughout the cutting season.

As a rule of thumb, never cut off more than 1/3 of the total grass blade length. Correct mowing height can reduce weeds and disease by 50% to 80%.

The following grass cut heights are based on adequate moisture conditions and normal thatch build-up in a healthy lawn. Some locations and applications may require slightly different cut heights. If in doubt, consult your local lawn professional for assistance.

<u>Grass Types</u>	<u>Best Cut Heights</u>
Bermudagrass	1 - 2"
Bluegrass	2 - 3"
Buffalograss	1 ^{1/2} - 3"
Ryegrass	2 - 3"
Tall Fescue	3 - 3 ^{1/2} "
Zoysiagrass	1 - 3"

OPERATION INSTRUCTIONS

TOWING TRAILERS AND OTHER ATTACHMENTS:

Towing a trailer or other attachment that is too heavy could damage the drive or cause the mower to become unstable. Limit loads to 500 pounds or less with this mower.

TO FREE WHEEL MACHINE (Unlock Transmission):

Always turn off engine before engaging or disengaging the hydro release (free wheel) lever. Never attempt to move the lever with the engine running.

The hydro release valves are located behind the seat, on the front side of the hydro pumps. To access the release valves, lift the seat frame assembly, use a 5/8" wrench to rotate bolt counter-clockwise two full turns to disengage pump. Repeat procedure for opposite pump. To engage, rotate each pump bolt clockwise until bolt is snug.

NOTE: Before pushing or towing tractor, transmission must be unlocked and parking brake released. The tractor should never be pulled at more than 2 miles per hour or for any appreciable distance.

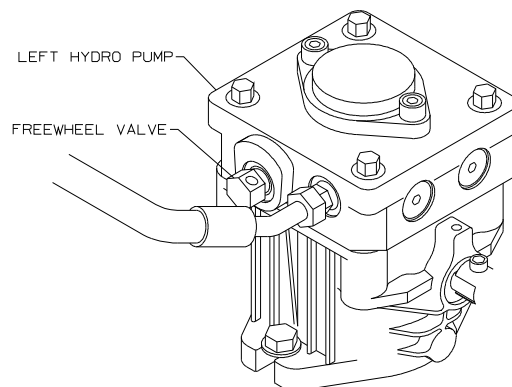

CARE AND MAINTENANCE

WARNING

Failure to observe the following instructions may result in personal injury.

*Before performing any maintenance, turn off engine,
allow to cool & remove key.
Use extreme care when working on machinery.
Do not wear watch or jewelry.
Do not wear loose fitting clothes, and observe all
common safety practices with tools.*

MAINTENANCE SCHEDULE

- Adjust traction drive idler.....after 5 hours break-in
- Check deck serpentine belt.....after 20 hours break-in
- Check crankcase oil level.....before each use
- Clean grass from hydrostat fans.....before each use
- Clean grass & debris from muffler & manifold area.....before each use
- Clean grass under deck.....after each use
- Check tire pressure.....every 10 hours
- Inspect blades for sharpness.....every 10 hours
- Check hydrostatic transmission fluid.....every 25 hours
- Clean air filter element.....every 25 hours
- Check traction drive idler adjustment.....every 50 hours
- Grease all zerks.....every 50 hours
- Check all belts.....every 50 hours
- Change engine crankcase oil & filter.....(5 hours break-in)every 50 hours
- Change engine oil filter.....every 50 hours
- Replace air filter element.....annually or every 100 hours
- Replace spark plugs.....every 100 hours
- Change hydrostat oil & oil filter.....(100 hours break-in)every 500 hours

CARE AND MAINTENANCE

CUTTER BLADE MAINTENANCE:



CAUTION Stop engine and remove ignition key for safety. Wear heavy, thick gloves when holding onto cutter blade, avoid the sharp edge of the blade.

Check sharpness of mower blades after every 10 hours of operation. Observe proper blade position prior to removal.

1. Safely raise front of mower.
2. Hold or block blade from turning.
3. Loosen blade bolt and remove blade.
4. When replacing blade, tighten blade bolt securely. Refer to diagram. Be sure blade is centered on pilot before tightening to 60 ft. lbs.

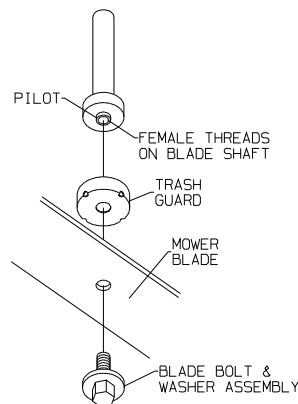

Blades should be discarded when worn excessively.

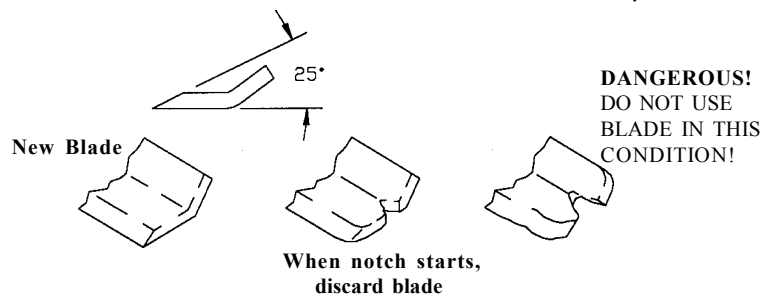

CARE AND MAINTENANCE

ENGINE:

For complete maintenance and operating information of the engine, please refer to the maintenance instructions furnished by the engine manufacturer included in your Zero Turn Radius mower information packet.

 **CAUTION** *Battery contains sulfuric acid electrolyte which is poisonous and corrosive.*

BATTERY:

This is a maintenance-free battery and the fluid level cannot be checked.

- Charge battery if required.

OFF SEASON BATTERY STORAGE:

- DO NOT remove battery from mower.
- Clean top of battery and terminals with baking soda and water.
- Identify each cable so they can be reconnected to the correct terminal.
- Disconnect cables from terminals. ALWAYS disconnect ground cable first and reconnect last.
- Charge battery.

Note: Your Dixon® mower comes equipped with a quick disconnect harness for the optional Dixon® Battery Manager. The Dixon® Battery Manager maintains the proper charge levels during periods of inactivity and may prevent premature battery failures. Contact your dealer for more information.

CARE AND MAINTENANCE

TIRES:

Correct tire pressure is essential for efficient operation of the mower. Check tire pressure periodically. Inflate tires to the pressure listed below.

Front tires	13 x 5.00 - 6	16-21 lbs.
Rear tires	20 x 10.0 - 10	8-14 lbs.

Lug nuts or lug bolts should be checked regularly for tightness.

LUBRICATION:

CHASSIS: (9) grease zerks

LOCATIONS: front wheel casters (4)
mower deck hubs (3)
brake shafts (2)

SERVICE INTERVALS: Every 50 hours of operation or once per season.

RECOMMENDED GREASE: Name brand wheel bearing or multi-purpose grease (3 pumps each)

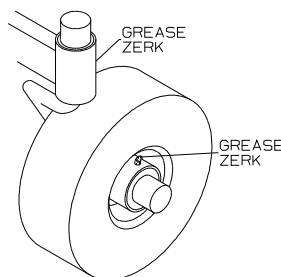

CARE AND MAINTENANCE

BELTS:

Check belts every 50 hours. Replace any belts found to be in poor condition.

BELT TENSION:

Mower Deck Serpentine Belt: P/N 1300 (50")
P/N 9758 (60")

Manual adjustment. Refer to illustration for adjustment procedure.

Engine to Mower Deck Belt: P/N 6111 (50")
P/N 17179 (60")

The engine to mower deck drive belts are automatically held in proper tension by springs which push the deck assembly forward and do not require any additional adjustment to be made.

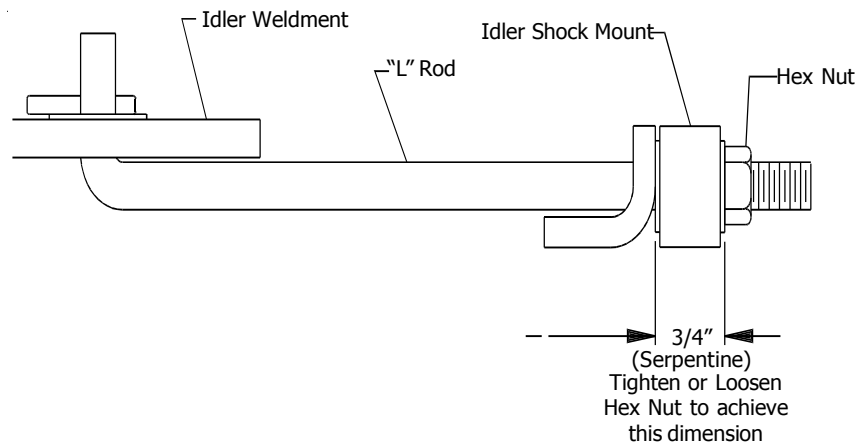

Note: Belt deflection or movement should be approximately 1/4" when measured at mid-point between pulleys. Periodically inspect both belt and idler systems.

CARE AND MAINTENANCE

 **CAUTION** HOT oil may cause burns. Allow engine to cool before draining oil.

CHANGING THE ENGINE OIL:

1. The “Dapco” oil drain valve is located on either side of the engine crankcase (depending on the type of engine installed on your ZTR®).
2. Place a suitable container under the drain valve hose.
3. To drain, turn hex head valve stem counter-clockwise with a 10mm wrench or socket. Open to full open (approximately 7 turns).
4. After engine is drained, tighten hex stem.
5. Change oil filter.
6. Fill with oil (see steps on next page).

NOTE: Refer to engine manufacturer’s recommendations for frequency of oil changes.

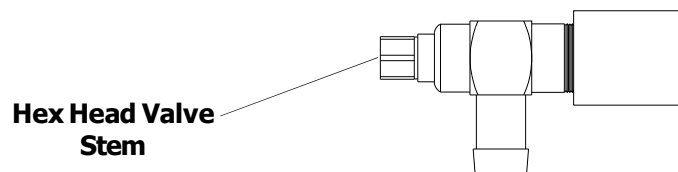

CARE AND MAINTENANCE



CAUTION HOT oil may cause burns. Allow engine to cool before draining oil.

OIL FILL:

1. Clean any spilled oil from engine and chassis.
2. Refill engine with type, and quantity of oil recommended by the engine manufacturer in engine literature.

NOTE: Engine oil changes on the KODIAK™ will require replacement of the oil filter. These filters may be available from your local Dixon® Dealer.

OIL FILTERS:

1. Replace filter each time the oil is changed.
2. Oil Filters can be obtained from your authorized engine dealer.
3. The use of any other oil filter may cause damage to the engine.

*PLEASE DISPOSE OF USED OILS AT PROPER COLLECTION CENTERS.
PROTECT YOUR ENVIRONMENT.*

CARE AND MAINTENANCE

HYDROSTATIC TRANSMISSION FLUID & FILTER SERVICE:

Dirt or water in fluid can ruin the hydrostatic transmissions.

SERVICE INTERVALS:

1. Initial filter service - 100 hours
2. Every 500 hours or once a year thereafter.

RECOMMENDED FLUID:

All temperatures -

Dixon Blue™ 15W-50 Synthetic Hydrostatic Fluid

~or if not available~

Normal Operating Temperatures - 20W50 engine oil

Cold climate usage - 10W40 engine oil

Use engine oil with an API classification of SG/CD.

Dixon Blue™ 15W-50 Synthetic Hydrostatic Fluid is specifically formulated to provide excellent all-temperature performance and extended time between oil changes.

FLUID FILTER: P/N 18045 - IMPORTANT

The fluid filter is a special design for use on "vacuum or suction" oil flow systems.

DO NOT: Use automotive engine oil filters. These filters require a "pressure" to allow oil flow. Usage will result in an "air-lock" condition with possible damage.

CARE AND MAINTENANCE

HYDROSTAT FLUID MAINTENANCE PROCEDURE:

Check the fluid level in hydrostatic transmission fluid reservoir after every 25 hours of usage. Clean the fluid reservoir cap and the area around it prior to removal. Check the fluid level. Fluid should be approximately 1/4" below top of fluid tank baffle. Replenish as needed with **Dixon Blue™ 15W-50 Synthetic Hydrostatic Fluid**. DO NOT OVERFILL. When checking the fluid level, be very careful to keep the reservoir clean.

Change the fluid in the reservoir and hydrostatic transmission fluid filter after the first 100 hours of use, then every 500 hours after that. Remove the filter and be sure all fluid has drained from the reservoir. Replace with a new OEM filter (P/N 18045) and **Dixon Blue™ 15W-50 Synthetic Hydrostatic Fluid**.



CAUTION: **Dixon Blue™** is only compatible with standard 20W-50 motor oil or similar synthetic motor oils.

DO NOT USE OR ADD STANDARD (RED) HYDRAULIC/ TRANSMISSION OIL IN YOUR DIXON HYDROSTATIC DRIVE. DAMAGE TO THE DRIVE COMPONENTS MAY OCCUR. USE ONLY APPROVED **DIXON BLUE™ 15W-50 SYNTHETIC HYDROSTATIC FLUID** OR 20W-50 TYPE ENGINE OIL.

CARE AND MAINTENANCE

NEUTRAL ADJUSTMENT

1. Lift seat.
2. Block up the unit so that the drive wheels are off the ground.
3. Loosen ball joint jam nuts on control rod.
Note: The front jam nuts are left hand threads.
4. With steering control arms in the "out" neutral position, start the engine and run at fast idle.
5. Adjust the neutral position by turning the control rod until the wheels do not rotate.
6. Re-tighten the jam nuts on the control rod and check to see that the drive wheels are not turning.
7. Repeat steps 3-6 for the other side.
8. Shut off engine before removing the blocks.

CARE AND MAINTENANCE

NEUTRAL SPRING ADJUSTMENT:

1. Loosen set screws on center spring stop collar located on the control rods. (Requires a 1/8" Allen wrench).
2. Swing control lever out. Tighten set screw on lock collar.
3. Repeat for opposite side.
4. Engage parking brake and lower seat frame. Release parking brake and swing control levers in. If wheel creeps, repeat steps 1 and 2.
5. Stop engine and remove rear of machine from jack or blocks.
6. Return the seat to the operating position.
7. Drive machine with both levers in top speed position. If one side now drives slightly faster than the other adjust forward speed bolt in to contact stop sooner.

CARE AND MAINTENANCE

MOWER DECK LEVELING PROCEDURE:

There are a total of (4) threaded adjusters which will control the attitude or pitch of the mower deck. The adjusters have locknuts on the bottom which can be turned up or down to raise or lower the front and rear of the mower deck. Deck should be level or pitched slightly higher in rear.

- A. Place the mower on a smooth level surface with front casters positioned towards deck. Check tire pressures to insure the mower has a correct stance. Inflate tires as required:

Front 16 - 21 lbs maximum

Rear: 8-14 lbs maximum

NOTE: To insure accuracy of leveling procedure, mower deck drive belt must be installed prior to leveling deck.

- B. Wear heavy gloves. Turn each outer blade tip to align with the deck or in a side-to-side manner.
- C. Measure from the floor surface up to the bottom of the blade tip on the discharge side of the mower deck. Retain this measurement. Move to the opposite side, check that measurement is the same. If adjustment is required, turn the nut on the bottom of the front threaded adjuster up or down until both side-to-side measurements are equal. Retain measurement.

CARE AND MAINTENANCE

MOWER DECK LEVELING PROCEDURE (continued):

- D. Turn both outer blades to align with the deck in front-to-rear manner. Turn left rear adjuster nut up or down until rear of mower deck is positioned level to 1/8" higher in the rear than the side-to-side measurement. At this time, the mower deck will be suspended on (3) points (both front adjusters and the left rear adjuster). Move the right rear adjuster and take out the slack which will be present by turning adjuster locknut up.
- E. Confirm measurements once again. Blade tips should be level in a side-to-side manner. In the rear, blade tips should be level to 1/8" higher than side-to-side measurement. In the front, blade tips should be level to 1/8" lower than side-to-side measurement.

NOTE: This will place the mower deck in a base measurement position. Additional adjustment may be required to achieve desired cut for the type of grass or conditions being mowed.

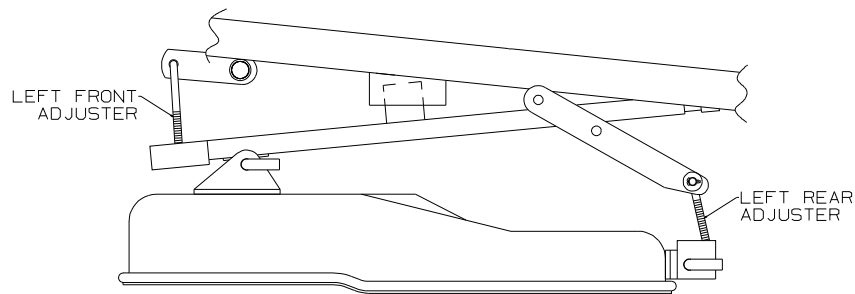

DECK LEVELING ADJUSTMENT POINTS

CARE AND MAINTENANCE

ELECTRICAL SYSTEMS:

Keep all connections clean and tight.

CLEANING THE MOWER:

Wash mower periodically. Clean above and below deck.

High pressure washing and alkaline based soaps can cause damage to bearings and other parts of the mower. After washing your mower, start the engine and engage the mower deck for a few minutes to disperse any water that may have accumulated in bearings, pulleys or fans.

Note: Allow mower to cool before washing. If bearings are hot, they will draw moisture inside as they dry and cause corrosion.

SERIAL NUMBERS:

The serial number is located on frame at rear of engine.

WARRANTY:

Refer to warranty information (page 16).

PARTS/SERVICE:

See your Dixon® dealer for replacement parts, warranty or service.

CARE AND MAINTENANCE

MOWER DECK REMOVAL:

1. Remove mower deck drive belt. To relieve belt tension, insert 5101 link (at front of lift frame) into tab illustrated below. Move lift handle into the lowest cut position. Belt can now be removed from mower deck pulley.

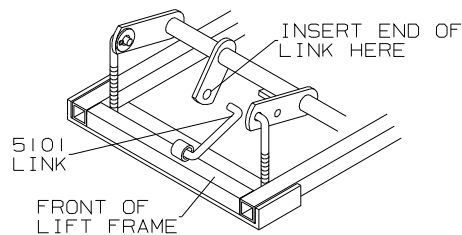

2. Remove front and rear deck hanger pins, as illustrated below.

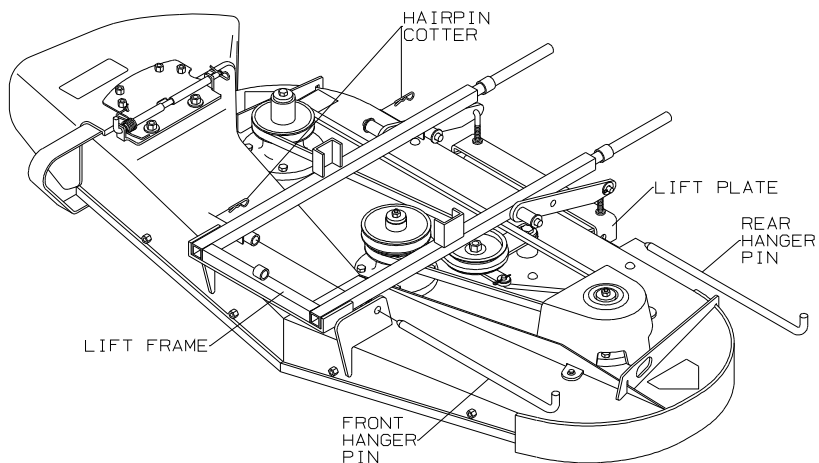

3. Slide deck from beneath chassis.
4. Reverse procedure to re-install deck to chassis.

TROUBLESHOOTING

1. ENGINE WON'T TURN OVER

Mower blades engaged- ----- disengage blades
Parking brake not on- ----- engage parking brake
Circuit breaker trips- ----- reset breaker
Dead battery- ----- charge or replace
Solenoid- ----- consult dealer
Ignition switch- ----- consult dealer
Starter- ----- consult dealer

2. ENGINE WILL TURN OVER BUT WON'T START

No fuel- ----- refuel and/or clean or replace fuel filters

3. HARD TO START ENGINE

Fuel line clogged- ----- clean fuel line and check fuel filter
Faulty fuel pump- ----- consult dealer

4. ENGINE STARTS BUT CUTS OUT

Water in fuel- ----- drain old fuel-replace with new fuel
Clogged fuel line- ----- check fuel filter
Fuel tank vent plugged- ----- clean fuel vent
Faulty fuel pump- ----- consult dealer

5. ENGINE OVERHEATED

Air intake screen or fins clogged- ----- clean intake screen and fins
Oil level too low or too high- ----- adjust oil level
Running engine too slow ----- run engine faster

TROUBLESHOOTING

6. ENGINE RUNS BUT MOWER WON'T MOVE FORWARD

Drive belt broken or slipping- ----- replace drive belt
Transmission oil low- ----- add oil
Damaged transmission- ----- -consult dealer
Transmission by-pass may be engaged- --- disengage(see page 32)

7. MOWER LOSES POWER OR TRANSMISSION OVERHEATS

Engine air filter- ----- clean or replace
Transmission damage- ----- -consult dealer

8. ENGINE STALLS WHEN BLADES ARE ENGAGED

Operator not on seat- ----- -sit on seat
Faulty interlock system- ----- consult dealer
Faulty blade spindle bearing - ----- consult dealer
Deck drive belt not properly routed- ----- reroute
Blades blocked by foreign material - ----- clean under deck

9. DRIVE SYSTEM

Mower pulls to side- ----- -check tire inflation/adjust control linkage
Mower creeps in neutral- ----- adjust control linkage
Low on power- ----- -check belt tension

10. CUT QUALITY

Cut uneven left to right- ----- -check tire inflation/level deck
Ends of grass blades are ragged- ----- sharpen blades
Poor dispersal of grass- ----- clean deck/check for loose belt
Skips in spots- ----- -check for loose belt/slow ground speed

STANDARD SERVICE PARTS LIST

50''

Blades

*Hi-Lift Fusion - P/N 13919
Super Hi-Lift Fusion - P/N 13868
Hi-Lift - P/N 13948
Standard Lift Fusion - P/N 13950
Standard Lift - P/N 13949
Gator Fusion - P/N 13952

*Factory installed

Belts

Engine to Mower Deck - P/N 6111
Serpentine - P/N 1300
Engine to Hydros - P/N 10959

60''

Blades

*Hi-Lift Fusion - P/N 13921
Super Hi-Lift Fusion - P/N 13869
Hi-Lift - P/N 13953
Standard Lift Fusion - P/N 13997
Standard Lift - P/N 13996
Gator Fusion - P/N 13955

*Factory installed

Belts

Engine to Mower Deck - P/N 17179
Serpentine - P/N 9758
Engine to Hydros - P/N 10959

ENGINE AIR AND OIL FILTERS

Refer to Engine Operator's Manual for correct service intervals for engine oil changes and air filter maintenance.

Protect your engine investment, use only original equipment filters. Refer to the Engine Operator's Manual or ask your dealer for correct replacement parts.



OWNER'S INFORMATION

Date of Purchase _____

Mower Model Number _____

Mower Serial Number _____

Purchased From _____

Name

Address

DATE OIL CHANGED

DATE ENGINE TUNED

_____	_____
_____	_____
_____	_____
_____	_____
_____	_____
_____	_____
_____	_____
_____	_____
_____	_____
_____	_____
_____	_____

Dixon Industries, Inc.~P.O. Box 1569~Coffeyville, Ks~620-251-2000~Fax 620-251-4117

DIXON® ZTR®

Dixon® and ZTR® are registered trademarks of
Dixon Industries, Inc.



WARNING:

The engine exhaust from this product contains chemicals known to the State of California to cause cancer, birth defects or other reproductive harm.

DIXON INDUSTRIES, INC.
P.O. Box 1569
Coffeyville, Ks 67337-0945
620-251-2000

*KODIAK®
Part No. 18124-106*

Free Manuals Download Website

<http://myh66.com>

<http://usermanuals.us>

<http://www.somanuals.com>

<http://www.4manuals.cc>

<http://www.manual-lib.com>

<http://www.404manual.com>

<http://www.luxmanual.com>

<http://aubethermostatmanual.com>

Golf course search by state

<http://golfingnear.com>

Email search by domain

<http://emailbydomain.com>

Auto manuals search

<http://auto.somanuals.com>

TV manuals search

<http://tv.somanuals.com>