

DYNE X TM ●●●

19" LCD TV

DX-LCD19-09

USER GUIDE

Dynex DX-LCD19-09

19" LCDTV 720P

Contents

CHILD SAFETY	3
Important safety instructions	4
Features	5
Front	5
Remote control	6
Setting up your TV	7
Installing remote control batteries	7
Connecting your TV to a power outlet	7
Connecting an outside antenna	7
Connecting cable TV	7
Connecting to an external signal source	8
Connecting a computer	8
Using your TV	8
Turning your TV on and off	8
Selecting the TV signal source	9
Setting up the channel list	9
Changing channels	9
Selecting a digital sub-channel	9
Adjusting the volume	9
Displaying status information	9
Checking the DTV signal strength	9
Adding a channel label	9
Freezing the picture	10
Setting the clock	10
Setting the sleep timer	10
Viewing closed captions	10
Setting parental controls	10
Using the on-screen menu	11
On-screen menus	12
Maintaining	12
Cleaning your TV	12
Troubleshooting	13
Appendix	14
Specifications	15
Legal notices	15
One-year limited warranty	17

CHILD SAFETY

It makes a difference how and where you use your flat panel display

As you enjoy your new product, keep these safety tips in mind

The issue

The home theater entertainment experience is a growing trend, and larger TVs are popular purchases. However, TVs are not always supported on the proper stands or installed according to the manufacturer's recommendations. We and the consumer electronics industry are committed to making home entertainment enjoyable and safe.

TVs that are inappropriately placed on dressers, bookcases, shelves, desks, speakers, chests, or carts may fall over and cause injury.

Tune into safety

- One size of TV stand does **not** fit all. Use only a TV stand rated for the weight of your TV.
- Carefully read and understand all enclosed instructions for proper use of this product.
- Don't let children to climb on or play with entertainment system furniture and TVs.
- Don't place TVs on furniture that can easily be used as steps, such as a chest of drawers.
- Remember that children can become excited while watching a program, especially on a "larger-than-life" TV. Make sure that you place or install the TV where it cannot be pushed, pulled over, or knocked down.
- Make sure that you route all cords and cables so that they cannot be pulled or grabbed by curious children.



Wall mounting

If you decide to wall mount your TV, always:

- One size of wall mount does **not** fit all. Use only a wall mount rated for the weight of your TV and that has been recommended by this TV manufacturer, listed in this manual, or otherwise listed by an independent laboratory (such as UL, CSA, or ETL) as suitable for your TV.
- Follow all instructions supplied by the TV and wall mount manufacturers.
- If you have any doubts about your ability to safely wall mount your TV, get help from a professional installer.
- Make sure that the wall where you are mounting the TV is appropriate. Some wall mounts are not designed to be mounted to walls backed with steel studs or cinder blocks. If you are unsure, ask a professional installer.
- TVs can be heavy. At least two people are required for safe wall mount installation.



Important safety instructions



This symbol indicates that dangerous voltage constituting a risk of electric shock is present within your TV. This label is located on the back of your TV.



This symbol indicates that there are important operating and maintenance instructions in the literature accompanying your TV.

- 1 Read these instructions.
- 2 Keep these instructions.
- 3 Heed all warnings.
- 4 Follow all instructions.
- 5 Do not use this apparatus near water.
- 6 Clean only with dry cloth.
- 7 Do not block any ventilation openings. Install in accordance with the manufacturer's instructions.
- 8 Do not install near any heat sources such as radiators, heat registers, stoves, or other apparatus (including amplifiers) that produce heat.
- 9 Do not defeat the safety purpose of the polarized or grounding-type plug. A polarized plug has two blades with one wider than the other. A grounding type plug has two blades and a third grounding prong. The wide blade or the third prong is provided for your safety. If the provided plug does not fit into your outlet, consult an electrician for replacement of the obsolete outlet.
- 10 Protect the power cord from being walked on or pinched particularly at plugs, convenience receptacles, and the point where they exit from the apparatus.
- 11 Only use attachments/accessories specified by the manufacturer.
- 12 Use only with a cart, stand, tripod, bracket, or table specified by the manufacturer, or sold with the apparatus. When a cart is used, use caution when moving the cart/apparatus combination to avoid injury from tip-over.
- 13 Unplug this apparatus during lightning storms or when unused for long periods of time.
- 14 Refer all servicing to qualified service personnel.



S3126A

Warnings

Electric shock hazard

To reduce the risk of electric shock, do not remove any cover or expose the device to rain or moisture. No user-serviceable parts are inside. Refer servicing to qualified service technicians.

Lightning

For added protection for your device receiver during a lightning storm, or when it is left unattended and unused for long periods of time, unplug it from the power outlet and disconnect any antenna or cable system. This helps prevent property damage and personal injury from lightning and power line surges.

Power lines

An outside antenna system should not be located in the vicinity of overhead power lines or other electric light or power circuits, or where it can fall into such power lines or circuits. When installing an outside antenna system, extreme care should be taken to keep from touching such power lines or circuits as contact with them might be fatal.

Handling the LCD panel

- Your TV's screen is made of glass. Do not drop your TV or hit, jolt, or press hard against the LCD panel. If the screen breaks, be careful of broken glass.
- If the LCD panel is broken, make absolutely sure that you do not touch the liquid in the panel. This may cause skin inflammation.
- If the liquid gets in your mouth, immediately gargle, rinse, and consult with your doctor. Also, if the liquid gets in your eyes or touches your skin, consult with your doctor after rinsing for at least 15 minutes or longer in clean water.

Replacement parts

When replacement parts are required, make sure that the service technician uses replacement parts specified by the manufacturer that have the same characteristics as the original part. Unauthorized substitutions may result in fire, electric shock, personal injury, or other hazards.

Safety check

After completing any service or repair to this device, ask the service technician to perform routine safety checks to determine that your TV is in correct operating condition.

Power source

Operate your TV only from the type of power source indicated on the marking label. If you are not sure of the type of power supplied to your home, consult an electrician or your local power company.

Cautions

Damage requiring service

Unplug this TV from the power outlet and refer servicing to qualified service personnel under the following conditions:

- When the power supply cord or plug is damaged or frayed.
- If liquid has been spilled or objects have fallen into your TV.
- If your TV has been exposed to rain or water.
- If your TV does not operate normally by following the operating instructions. Adjust only those controls that are covered by the operating instructions because incorrect adjustment of other controls may result in damage and will often require extensive work by a qualified technician to restore your TV to its normal operation.
- If your TV has been dropped or damaged in any way.
- When your TV exhibits a distinct change in performance.

Attachments

Use only attachments recommended by Dynex.

Outdoor antenna grounding

If an outside antenna or cable system is connected to your TV, make sure that the antenna or cable system is grounded to provide some protection against voltage surges and built-up static charges. Article 810 of the National Electrical Code, ANSI/NFPA No. 70, provides information with respect to correct grounding of the mast and supporting structure, grounding of the lead-in wire to an antenna discharge unit, size of grounding conductors, location of the antenna-discharge unit, connection to grounding electrodes, and requirements for the grounding electrode.

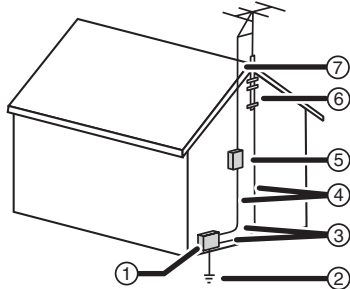

1	Electric service equipment
2	Power service grounding electrode system
3	Ground clamps
4	Grounding conductors
5	Antenna discharge unit
6	Grounding clamp
7	Antenna lead-in wire

Note to CATV system installer

Article 820 of the National Electrical Code, ANSI/NFPA No. 40 provides guidance for correct grounding. Specifically, it states that the cable ground must be connected to the grounding system of the building as close to the point of cable entry as practical.

Condensation

Moisture will form on the TV if the TV is brought from cool surroundings into a warm room or if the temperature of the room rises suddenly. When this happens, the TV's performance may be impaired. To prevent this, let the TV stand in its new surroundings for about an hour before switching it on, or make sure that the room temperature rises gradually. Condensation may also form during the summer if the TV is exposed to the breeze from an air conditioner. In such cases, change the location of the TV.

Mobile telephone warning

To avoid interference with your TV picture and sound, operating problems, or even damage, keep your cordless and cellular telephones away from the TV.

End of life directives

Your TV contains tin-lead solder and a fluorescent lamp containing a small amount of mercury. Disposal of these materials may be regulated for environmental reasons. Your TV also contains material that can be recycled and reused. For disposal or recycling information, contact your local authorities or the Electronic Industries Alliance at www.eia.org to find a recycler in your area.

Non-active pixels

The LCD panel contains almost 3 million thin film transistors, which provide exceptionally sharp video quality. Occasionally, a few nonactive pixels may appear on the screen as a fixed blue, green, or red point. These non-active pixels do not adversely affect the performance of your TV, and are not considered defects.

Features

Front

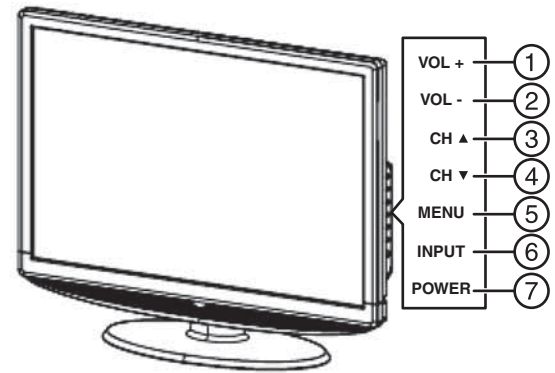

#	Button	Description
1	VOL+	Press to increase the volume. In Menu mode, functions as the right arrow to go to the next menu or increase a setting.
2	VOL-	Press to decrease the volume. In Menu mode, functions as the left arrow to go to a previous menu or decrease a setting.
3	CH ▲	Press to go to the next higher channel. In Menu mode, functions as the up arrow.
4	CH ▼	Press to go to the next lower channel. In Menu mode, functions as the down arrow.
5	MENU	Press to show the on-screen menu.
6	INPUT	Press to open the input source menu, then press the arrow buttons to cycle through the available input sources.
7	POWER	Press to turn on your TV or put it into Standby mode.

Remote control

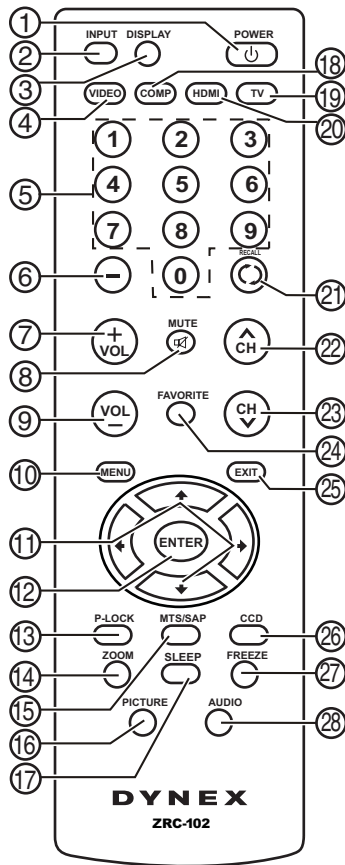

#	Button	Description
13	P.LOCK	Press to activate or deactivate parental controls. See "Setting parental controls" on page 10 for information on setting up parental controls.
14	ZOOM	Press to select the display aspect ratio.
15	MTS/SAP	In NTSC mode, press to select one of the preset audio modes. You can select MONO , STEREO , or SAP (secondary audio program). In ATSC mode, press to select the audio language.
16	PICTURE	Press to select the Brightness or Contrast setting. You can adjust these settings without opening the on-screen menu.
17	SLEEP	Press to set the sleep timer. For more information, see "Setting the sleep timer" on page 10.
18	COMP	Press to select the component source mode.
19	TV	Press to select the ATSC (digital), or NTSC (analog) TV source.
20	HDMI	Press to select the HDMI mode.
21	○ RECALL	Press to watch the previous channel.
22	CH ^	Press to tune to the next higher channel in the channel list.
23	CH v	Press to tune to the next lower channel in the channel list.
24	FAVORITE	Press to toggle the Favorite/Normal mode. See "Setting up the channel list" on page 9 for more information.
25	EXIT	Press to close the on-screen menu.
26	CCD	Press to turn closed captions on and off. For more information, see "Viewing closed captions" on page 10.
27	FREEZE	Press to freeze the video image. Press again to unfreeze the image. Do not freeze the video image for long periods of time. You may damage the TV screen.
28	AUDIO	Press to select the bass or treble setting. You can adjust these settings without opening the on-screen menu.

Using the remote control

To use the remote control:

- Point the remote control towards the remote sensor on the front of your TV.

Notes:

Do not expose the remote control to shock or liquids.

Do not use the remote control in an area with high humidity.

Do not place the remote control in direct sunlight.

Do not place objects, such as furniture, between the remote control and the remote sensor.

The remote control may not work if direct sunlight or bright light shines on the remote sensor. Either move your TV or change the angle at which you use the remote control.

#	Button	Description
1	POWER	Press to turn on your TV or put it into Standby mode.
2	INPUT	Press to cycle through the available input sources.
3	DISPLAY	Press to display status information.
4	VIDEO	Press to toggle between S-Video and composite source modes.
5	Number buttons	Press to enter channel numbers. In the on-screen menu, press to enter your parental control password.
6	-	Use with the 0-9 number buttons and ENTER button to select digital channels.
7	VOL +	Press to increase the volume.
8	MUTE	Press to mute the sound. Press again to restore the sound.
9	VOL -	Press to decrease the volume.
10	MENU	Press to open the on-screen menu.
11		Press to move down, up, left, or right in the on-screen menu.
12	ENTER	Press to confirm changes or to turn options on and off in the on-screen menu.

Setting up your TV

Installing remote control batteries

To install the remote control batteries:

- 1 Remove the battery cover.

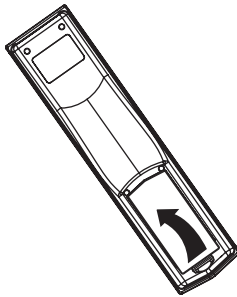

- 2 Insert two AAA batteries into the battery compartment. Make sure that you match the + and – symbols on the batteries with the + and – symbols in the battery compartment.

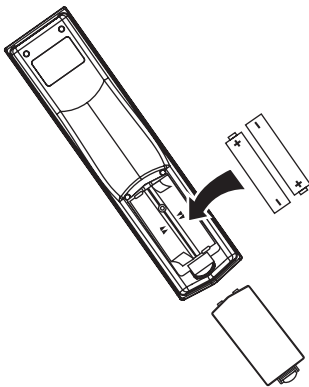

- 3 Replace the cover.

Notes:

Do not mix batteries of different types.

Do not mix old and new batteries.

Remove batteries when the charge is depleted.

Battery chemicals can cause a rash. If the batteries leak, clean the battery compartment with a cloth. If chemicals touch your skin, wash immediately.

If the remote control is not going to be used for an extended period of time, remove the batteries.

Connecting your TV to a power outlet

To connect your TV to a power outlet:

- Plug the power cord into a power outlet.

Notes:

Make sure that you use the correct type of power. See the label on your TV.

If you do not intend to use your TV for an extended period of time, unplug the power cord from the power outlet.

Connecting an outside antenna

Antenna cables come in two types: 75 ohm and 300 ohm.

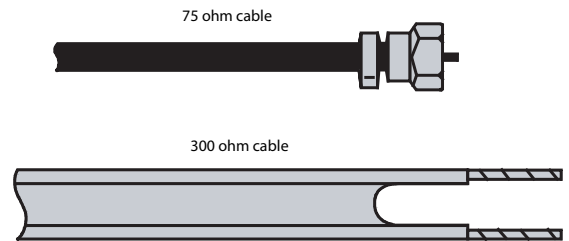

- If your antenna cable has a 75 ohm connector, connect the cable to the coaxial jack on the back of your TV.
- If your antenna cable has a 300 ohm connector, connect the cable to a 300-75 ohm adapter (not included), connect the adapter to a 75 ohm cable, then connect the other end of the 75 ohm connector to the coaxial jack on the back of your TV.

Connecting cable TV

Your TV has a 75 ohm jack for connecting cable TV.

Some cable TV providers scramble the signals for “premium” (pay) channels. To view these channels, you need a converter/descrambler box.

If you do not have a converter/descrambler box, you can connect your cable TV directly to your TV. If you have a converter/descrambler box, you can connect your cable TV using an RF switch (not supplied). For more information about connecting a converter/descrambler box, contact your cable TV provider.

To connect cable TV without a converter/descrambler box:

- 1 Connect one end of a 75 ohm cable to the coaxial jack on the back of your TV.
- 2 Connect the other end of the cable to the cable TV wall outlet.

To connect cable TV with a converter/descrambler box:

- Use the following illustration to connect a converter/descrambler box. (The RF switch and the signal splitter are not provided.) Set the RF switch to the **A** position to tune to unscrambled channels using your TV remote control. Set the RF switch to the **B** position to watch scrambled channels using the converter/descrambler controls.

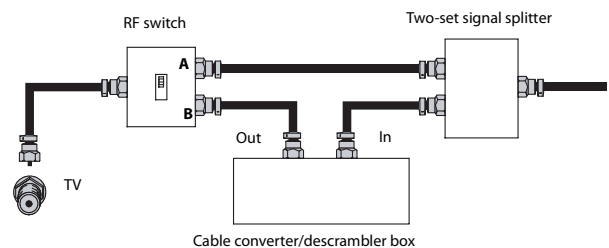

Connecting to an external signal source

You can connect a DVD, VCD, VCR, or STB using a variety of methods, including composite cables, component cables, an S-Video cable, or an HDMI cable. The S-Video cable does not carry sound. If you use an S-Video cable, you need to use audio cables to connect the audio output.

Warning: Make sure that you turn off and unplug your TV before connecting devices.

Note: For better video, use the **S-Video** jack if your device has an S-Video connection. For best video, use the **HDMI** jack if your device has an HDMI connection.

To connect an external signal source:

1 For composite video—Plug the audio/video cable into the **AUDIO L**, **AUDIO R** (2), and **VIDEO** (4) jacks on the back of your TV, then connect the other ends to the corresponding jacks on the external signal source.

Or

For S-Video—Plug in the audio cables as described above, then plug one end of an S-Video cable into the **S-VIDEO** (5) jack on the back of your TV, then plug the other end into the **S-Video** jack on the external signal source.

Or

For component video—Plug the Y, Pb, and Pr video cables into the **COMPONENT** (3) jacks and the Audio L and Audio R cables into the **AUDIO** (6) jacks on the back of your TV, then plug the other ends of the cables into the corresponding jacks on the external signal source.

Or

For HDMI—Plug one end of an HDMI cable into the **HDMI** (1) jack on the back of your TV, then plug the other end into an HDMI device.

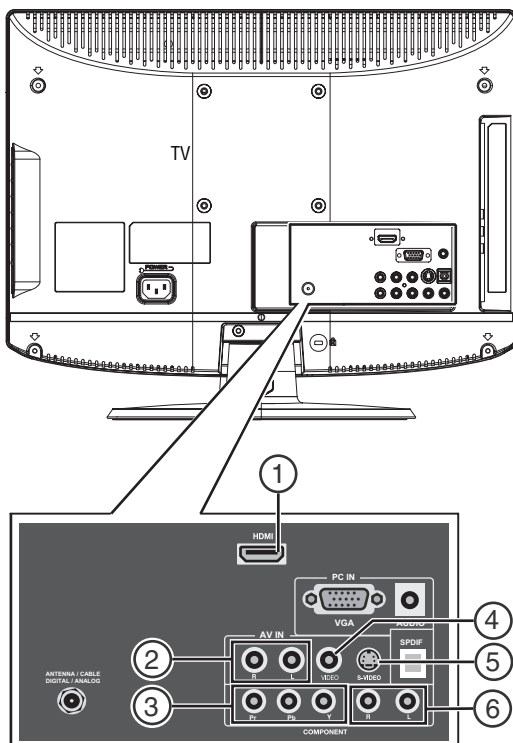

- 2 Turn on your TV.
- 3 Press **INPUT** repeatedly to select the external signal source you want to watch.
- 4 Turn on external signal source.
- 5 Insert a disc or videotape into the external signal source, then press **PLAY**.

Connecting a computer

You can connect a computer using the HDMI or VGA jack on the back of your TV.

Warning: Make sure that you turn off and unplug your TV before installing devices.

Note: When the computer goes into standby mode, your TV turns off. If your TV does not turn on when you "wake" your computer, press the **POWER** button on your TV or remote control.

To connect a computer using VGA:

- 1 Plug a VGA cable from your computer into the **VGA** jack on the back of your TV.

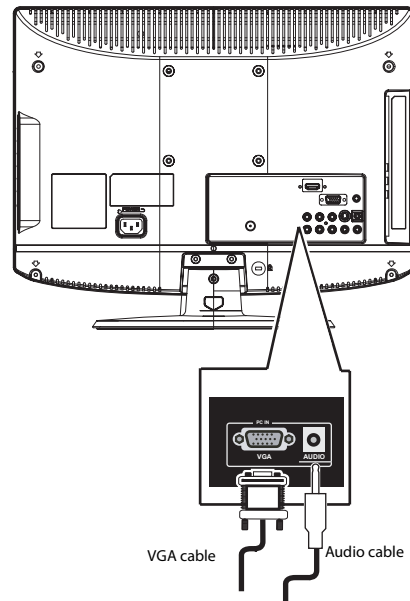

- 2 Plug an audio cable from your computer's audio out jack into the **AUDIO** jack on the back of your TV.
- 3 Plug in and turn on your TV.
- 4 Press **INPUT** repeatedly to select the **VGA** input source.

To connect a computer using HDMI:

- Plug an HDMI cable into the **HDMI INPUT** jack on the back of your TV and into the **HDMI Out** jack on the back of the computer.

Using your TV

Turning your TV on and off

To turn your TV on and off:

- 1 Make sure that the power cord is connected to your TV and a power outlet.
- 2 Press **⏻** to turn on your TV. The power indicator LED turns green.
- 3 Press **⏻** again to return your TV to standby. The power indicator LED turns red.

Selecting the TV signal source

To select the TV signal source:

- With the TV on, press **INPUT** on either the TV or the remote to choose from:
 - **TV**
 - **Composite**
 - **S-Video**
 - **Component**
 - **VGA**
 - **HDMI**

Note: HDMI, the HDMI logo, and High-Definition Multimedia Interface are trademarks or registered trademarks of HDMI Licensing LLC.

Setting up the channel list

After you select your TV source, if you selected antenna or cable you need to set up the channel list. When you set up your channel list, your TV searches for all available channels in your area and stores a list of these channels. When you press **CH -** or **CH +**, your TV skips the channels that do not have a signal.

Automatically setting up channels

To automatically set up the channel list:

- 1 Press **MENU**. The on-screen display menu opens with **Setup** highlighted.

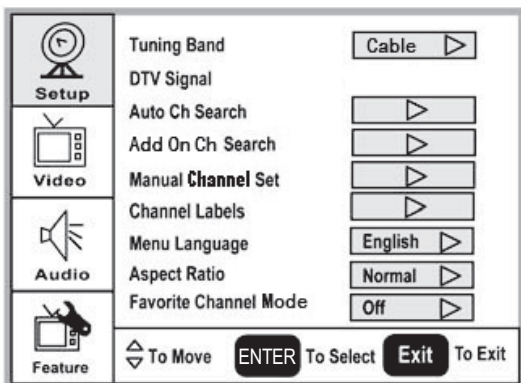

- 2 Press **▶** to enter the sub-menu, then press **▼** or **▲** to highlight **Auto Ch Search**.
- 3 Press **ENTER** or **▶** to start the search.

Note: You can press Exit to stop the search.

Manually adding or deleting channels from the channel list

After you create a channel list using the **Auto Ch Search** option, you can manually add or delete channels from the channel list.

To add or delete channels:

- 1 Press **MENU**. The on-screen display menu opens with **Setup** highlighted.
- 2 Press **▶** to enter the sub-menu, then press **▼** or **▲** to highlight **Manual Channel Set**. The *Channel Setup Table* opens.
- 3 Press **▼** or **▲** to select a channel, then press **ENTER** to toggle between viewable and not viewable.
- 4 Press **MENU** or **EXIT** to close the menu.

Changing channels

To change channels:

- Press **CH ▼** or **CH ▲** on the remote control to go to the next lower or higher channel.
 - Or
 - Press the number buttons to directly select a channel (for example, if you want channel 83, press **8**, then press **3**).
 - Or
 - Press **○** **RECALL** to go to the last viewed channel.

Selecting a digital sub-channel

Most digital TV channels have more than one channel. The main channel carries the signal for the main TV program. The sub-channels carry signals for additional or alternate programming, such as a radio or news broadcast.

For example, if the main channel number is 8, the sub-channel number might be 8-1, 8-2, or 8-3.

To select a sub-channel:

- 1 Press the number buttons for the main channel (for example 8).
- 2 Press **-**, then press the sub-channel button (for example 1).

Adjusting the volume

To adjust the volume:

- Press **VOL -** or **VOL +** to decrease or increase the volume.
- Press **MUTE** to turn off the sound. Press **MUTE** again to turn the sound back on.

Displaying status information

To display status information:

- Press **DISPLAY**. Your TV displays status information, such as the channel number or signal source.

Checking the DTV signal strength

To check the DTV signal strength:

- 1 Press **MENU**. The on-screen display menu opens with **Setup** highlighted.
- 2 Press **▶** to enter the sub-menu, then press **▼** or **▲** to highlight **DTV Signal**. The DTV signal meter opens.

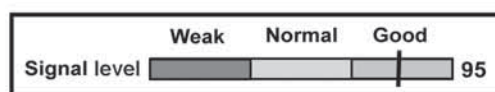

- 3 Press **MENU** or **EXIT** to close the menu.

Adding a channel label

To add a label to a channel:

- 1 Press **MENU**. The on-screen display menu opens with **Setup** highlighted.
- 2 Press **▶** to enter the sub-menu, then press **▼** or **▲** to highlight **Channel Labels**. The *Channel Label* menu opens.
- 3 Press **◀** or **▶** to move the cursor to the channel field, then press **▼** or **▲** to select a channel.
- 4 Press **◀** or **▶** to move the cursor to the label field, then press **▼** or **▲** to select the character.
- 5 Press **ENTER** to return to the previous menu.

Freezing the picture

You can freeze (still) the screen image.

Caution: To protect your TV, do not freeze the screen image for long periods of time.

To freeze or unfreeze the picture:

- Press **FREEZE**.

Setting the clock

To set the clock:

- 1 Press **MENU**. The on-screen display menu opens with **Setup** highlighted.
- 2 Press **▼** or **▲** repeatedly to highlight **Feature**. The *Feature* menu opens.

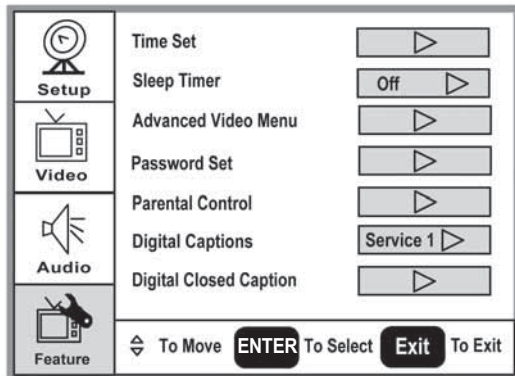

- 3 Press **▶** to enter the sub-menu, then press **▼** or **▲** to highlight **Time Set**. The *Time Set* menu opens.

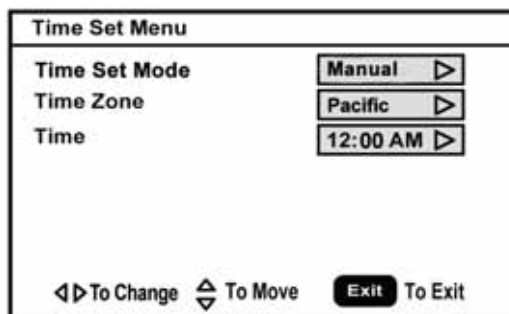

- 4 Press **▼** or **▲** move to the different fields, then press **◀** or **▶** to change the settings.
- 5 Press **MENU** or **EXIT** to close the menu.

Setting the sleep timer

The sleep timer lets you select the amount of time before your TV turns off automatically.

To set the sleep timer:

- 1 Press **MENU**. The on-screen display menu opens with **Setup** highlighted.
- 2 Press **▼** or **▲** repeatedly to highlight **Feature**. The *Feature* menu opens.
- 3 Press **▶** to enter the sub-menu, then press **▼** or **▲** to highlight **Sleep Timer**.
- 4 Press **◀** or **▶** to select the amount of time (**Off**, **5 min**, **10 min**, **15 min**, **30 min**, **45 min**, **60 min**, **90 min**, **120 min**, **180 min**, or **240 min**). To turn off the timer, select **Off**.

Note: You can also press **SLEEP** to set the sleep timer.

Viewing closed captions

Note: To select or customize digital closed captions, use the **Digital Captions** or **Digital Closed Caption** sub-menus in the *Feature* menu.

To view closed captions:

- Press **CCD** repeatedly to select a closed caption option. You can select:
 - **On**
 - **Off**
 - **On When Mute**

Setting parental controls

Your TV has a V-chip that lets you control the type of programs your children can watch. Parental controls include two ratings: MPAA (based on age) and TV Parental Guidelines (based on content and age). A TV program may have an MPAA or TV Parental Guidelines rating, so you should set controls for both ratings.

Before you can select ratings, you need to set up a parental controls password.

To set up a password:

- 1 Press **MENU**. The on-screen display menu opens with **Setup** highlighted.
- 2 Press **▼** or **▲** repeatedly to highlight **Feature**. The *Feature* menu opens.
- 3 Press **▶** to enter the sub-menu, then press **▼** or **▲** to highlight **Password Set**.
- 4 Press the number buttons to enter the old password. If you have not set a password, enter **0000**. Press **ENTER** to continue.

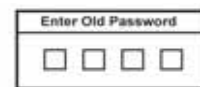

- 5 Press the number buttons to enter a new password. Press **ENTER** to continue.

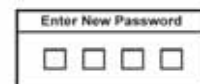

- 6 Press the number buttons to enter the new password again, to confirm. Press **ENTER** to continue.

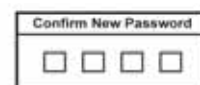

Caution: Write down your password and save it for future use.

Note: If you forget your password, enter **3448** for the old password, then enter a new password. This password always remains valid for resetting your password.

Setting the Parental Control level

To set the Parental Control level:

- 1 Press **MENU**. The on-screen display menu opens with **Setup** highlighted.
- 2 Press **▼** or **▲** repeatedly to highlight **Feature**. The *Feature* menu opens.
- 3 Press **▶** to enter the sub-menu, then press **▼** or **▲** to highlight **Parental Control**. The Password screen opens.

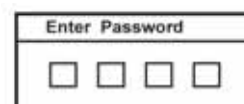

- Press the number buttons to enter the password. Press **ENTER** to continue. The *Parental Control Menu* opens.

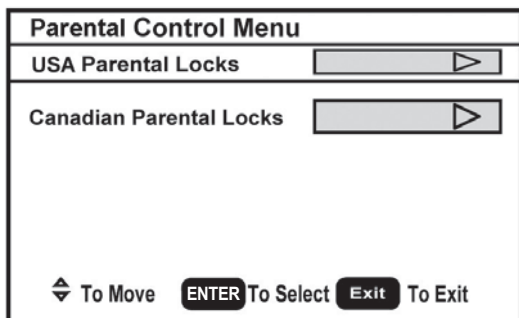

- Press **▼** or **▲** to select **USA Parental Locks** or **Canadian Parental Locks**, then press **ENTER**. The lock menu that you have selected opens.

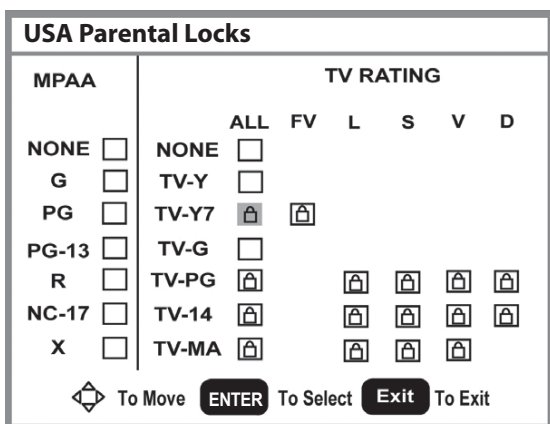

- Press **◀** or **▶**, or **▼** or **▲** to move to a rating, then press **ENTER** to select the rating.
- When you block a rating, that rating and all higher ratings are blocked.
- Press **MENU** or **EXIT** to close the menu.

American MPA A ratings

Rating	Description
NONE	Not rated.
G	General audiences.
PG	Parental guidance suggested. Some material may not be suitable for children.
PG-13	Parental guidance strongly suggested. Some material may not be suitable for children under 13 years of age.
R	Restricted. Not suitable for children under 17 years of age unless accompanied by a parent or guardian.
NC-17	Not suitable for children under 17 years of age.
X	Adults only.

Canadian MPAA Ratings

Rating	Description
C	Children.
C8+	Children 8 years and above.
G	General audience.
PG	Parental guidance suggested.
14+	14 years old and above.
18+	Adult programming.
X	Adults only.

TV Parental Guidelines ratings

Rating	Description
NONE	Not rated.
TV-Y	All children.
TV-Y7	Children over seven years.
TV-G	General audiences.
TV-PG	Parental guidance suggested.
TV-14	Parents strongly cautioned.
TV-MA	Mature audiences only.

Some of the age-based TV Parental Guidelines ratings also have content-based ratings.

Rating	Description
FV	Fantasy violence.
L	Adult language.
S	Sexual situations.
V	Violence.
D	Sexually suggestive dialog.

Using the on-screen menu

Your TV has an on-screen menu that lets you adjust TV settings, such as video and audio settings.

To use the on-screen menu:

- Press **MENU**. The on-screen display menu opens.
- Press **▼** or **▲** repeatedly to select a menu item.
- Press **◀** or **▶** to enter a sub-menu.

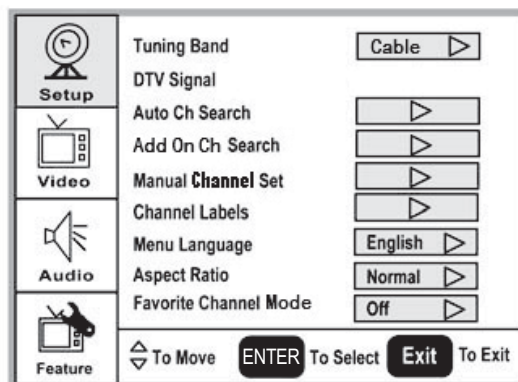

- Press **ENTER** or **▶** to confirm an adjustment or toggle a setting.
- Press **MENU** or **EXIT** to close the on-screen display menu.

On-screen menus

On-screen menu	Options
Setup	<p>Tuning Band—Selects the TV antenna source (Air or Cable).</p> <p>DTV Signal—Displays the digital TV signal strength. For more information, see “Checking the DTV signal strength” on page 9.</p> <p>Auto Ch Search—Automatically sets up a list of the channels available in your area. For more information, see “Automatically setting up channels” on page 9.</p> <p>Add On Ch Search—Lets you add new channels without going through the entire list of available channels.</p> <p>Manual Ch Set—Lets you add or delete channels from the channel list. For more information, see “Manually adding or deleting channels from the channel list” on page 9.</p> <p>Channel Labels—Lets you add a label to a channel. For more information, see “Adding a channel label” on page 9.</p> <p>Menu Language—Selects the language for the on-screen menu. You can select English, French, or Spanish.</p> <p>Aspect Ratio—Selects the screen aspect ratio: Normal, Wide1, Wide2, Zoom, or Cinema. You can also press ZOOM to select the aspect ratio.</p> <p>Favorite Channel mode—Lets you edit your favorite channel list. Press FAVORITE on the remote to toggle this mode on or off.</p>
Video (Options may vary in different modes.)	<p>Contrast—Increases the picture level to adjust the white areas of the picture. Decreases the picture level to adjust the black areas of the picture. (0 ~ 100)</p> <p>Brightness—Increases the brightness to add more light to dark areas of the picture. Decreases the brightness to add more dark to light areas of the picture. (0 ~ 100)</p> <p>Sharpness—Increases the sharpness for a cleaner and clearer image. Decreases the sharpness for a smoother picture. (-50 ~ 50)</p> <p>Color—Adjusts the overall color of the picture. (0 ~ 100)</p> <p>Tint—Increases the color level to add more green to skin tones. Decreases the color level to add more purple to skin tones. (R50 ~ G50)</p> <p>Backlight—Adjusts the backlight level (0 ~ 10).</p> <p>Settings—Restores the video settings to factory default.</p>
Audio (Options may vary in different modes.)	<p>Audio Language—Selects an alternate language if the program has more than one language available. Only available in ATSC TV mode.</p> <p>Bass—Adjusts the low sounds (bass).</p> <p>Treble—Adjusts the high sounds (treble).</p> <p>Balance—Adjusts the right and left speaker volumes.</p> <p>Digital Audio Output—Selects the audio mode for the digital audio optical jack.</p> <ul style="list-style-type: none"> • RAW: AC-3 in - AC-3 out/PCM in - PCM out. • PCM: AC-3 in - PCM out/PCM in - PCM out. <p>TV Speaker—Turns the internal TV speaker On (default) or Off. Does not affect the digital audio output, the headphone output, and the composite audio output.</p> <p>Settings—Restores the audio settings to factory default.</p>

On-screen menu	Options
Feature	<p>Time Set—Sets the clock. For more information, see “Setting the clock” on page 10.</p> <p>Sleep Timer—Sets the sleep timer. For more information, see “Setting the sleep timer” on page 10.</p> <p>Advanced Video Set—</p> <ul style="list-style-type: none"> • Noise Reduction—Select from Low, Mid, High, and Off. • Color Temperature—Select from Normal, Warm, and Cool (default). • 3D Y/C—Choose from On (default) or Off. • Setting—Restores the settings to factory default. • Dynamic Contrast—Choose from On (default) or Off. <p>Password Set—Lets you set the password for parental control options. The default password is 0000. See “Setting parental controls” on page 10.</p> <p>Parental Control—Accesses V-chip controls. For more information, see “Setting parental controls” on page 10.</p> <p>Digital Caption—Sets the digital caption type. Choose from Service 1-6, Text 1-4, and CC 1-4.</p> <p>Closed Caption Options—Customizes closed captions for digital broadcasting systems. You can adjust Size, Font, Text Color, Text Opacity, Background Color, Background Opacity, Edge Effect, and Edge Color.</p> <p>Component Set—Only available in component mode. Lets you set Horizontal Position (0 ~ 100), Vertical Position (0 ~ 100), Clock (0 ~ 100), and Phase (0 ~ 100). The Settings option restores the settings to factory default.</p> <p>VGA Set—Only available in VGA mode. Lets you set Horizontal Position (0 ~ 100), Vertical Position (0 ~ 100), Clock (0 ~ 100), and Phase (0 ~ 100). You can also select Auto Adjust to automatically adjust the settings. The Settings option restores the settings to factory default.</p> <p>Input Label—Lets you modify the input label.</p>

Maintaining

- Do not use your TV in areas that are too hot or too cold, because the cabinet may warp or the screen may malfunction.
 - Storage temperatures are 32° to 122°F (0° to 50°C).
 - Working temperatures are 41° to 104°F (5° to 40°C).
- Do not place your TV in direct sunlight or near a heat source.

Cleaning your TV

Clean the screen and cabinet with a soft, lint-free cloth. If the screen or cabinet is especially dirty, moisten a soft, lint-free cloth in a weak detergent solution, squeeze the excess moisture from the cloth, then wipe the screen or cabinet with the cloth. Use a clean cloth to dry the screen or cabinet.

Cautions: Avoid the following, because it may cause damage to your TV: Cleaning your TV with volatile substances, such as insect sprays, solvents, and thinners.

Leaving items made from rubber or PVC in contact with your TV for long periods.

Letting liquids drip into the cabinet.

Troubleshooting

Warning: Do not try to repair your TV yourself. Refer all service to a qualified service technician.

Symptom	Possible solution
No power	<ul style="list-style-type: none"> • Make sure that the power cord is connected to your TV and a power outlet. • Unplug the power cord, wait 60 seconds, then plug the cord back in and turn on your TV.
No picture	<ul style="list-style-type: none"> • Make sure that the video cables are connected securely to the back of your TV. • Adjust the contrast and brightness. • Make sure that the correct video mode is selected. • Make sure that the incoming signal is compatible. • Make sure that the antenna is connected correctly. • Check the closed caption settings. Some TEXT modes can block the screen.
Good picture but no sound	<ul style="list-style-type: none"> • Increase the volume. • Make sure that the sound is not muted. • Make sure that the correct audio mode is selected.
Good sound but poor color	<ul style="list-style-type: none"> • Adjust the contrast, color, and brightness settings.

Symptom	Possible solution
Poor picture	<ul style="list-style-type: none"> • Make sure that the room is not too bright. Light reflecting off the screen can make the picture difficult to see. • If an S-VHS camera or a camcorder is connected while another connected device is turned on, the picture may be poor. Turn off one or more devices.
Horizontal dotted line	<ul style="list-style-type: none"> • Your TV may be too close to another electrical device, such as a hair dryer or neon light. Turn off the device or move your TV.
"Ghost" or double image	<ul style="list-style-type: none"> • This may be caused by obstructions to the antenna, such as high-rise buildings or hills. Using a highly directional antenna may improve the picture quality.
Remote control does not work	<ul style="list-style-type: none"> • Press TV. • Replace the batteries. Make sure that the + and - symbols on the batteries align with the + and - symbols in the battery compartment. • Clean the remote sensor on the front of your TV. • Bright or fluorescent lighting may interfere with the remote control signal. Turn off the light or move your TV.
Snowy picture or noise	<ul style="list-style-type: none"> • Make sure that the A/V and antenna cables are connected correctly and securely.
VGA picture is not stable or synchronized	<ul style="list-style-type: none"> • Make sure that you have selected the correct VGA mode on your computer.
No output from one of the speakers	<ul style="list-style-type: none"> • Adjust the balance in the <i>Sound</i> menu.
Control buttons do not work	<ul style="list-style-type: none"> • Unplug the power cord, wait a few seconds, then plug the cord back in and turn on your TV.
After images appear	<ul style="list-style-type: none"> • Do not display a still image, such as a logo, game, or computer image, for an extended period of time. This can cause a permanent after image to be burned into the screen. This type of damage is not covered by your warranty.
Picture has a few bright or dark dots	<ul style="list-style-type: none"> • A few bright or dark dots on an LCD screen is normal. It does not affect the operation of this TV.

Appendix

Wall-mount hardware (sold separately) lets you mount your TV on a wall.

For detailed information on mounting your TV on a wall, see the instructions provided with the wall-mount hardware.

Contact a technician for assistance when installing the wall-mount bracket. Best Buy is not responsible for any damage to your TV or injury to yourself or others.

We suggest that you keep your TV at least 2.36 inches (60 mm) from the wall to prevent cable interference.

Before you wall-mount your TV, you need to remove the base.

To attach a wall mount bracket to your TV:

- 1 Remove the four M4 screws holding your TV to the stand.

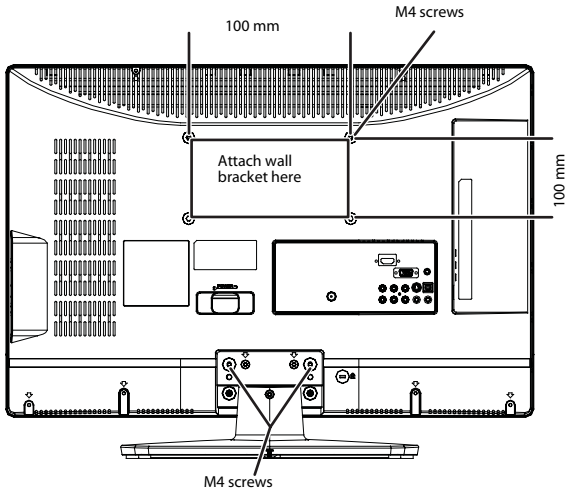

- 2 Remove the screw from the bottom of the base.

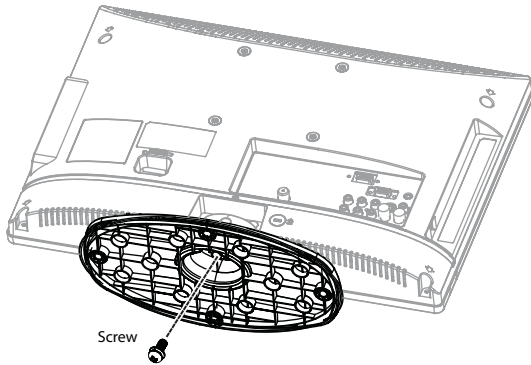

- 3 Remove the base.

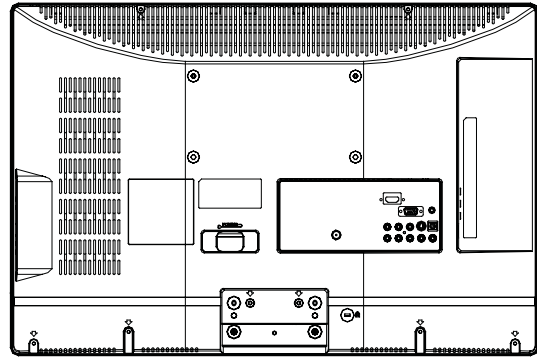

- 4 Secure the wall mount bracket to the back of your TV using one M4 screw, as indicated in the illustration.

Specifications

Design and specifications are subject to change without notice.

Analog standard	NTSC
Digital standard	ATSC, 8-VSB, Clear-QAM
Screen	19-inch
Channel coverage	VHF: 2-13 UHF: 14-69 CATV: Mid band - A-8 ~ A-1, A ~ I Super band - J ~ W Hyper band - AA ~ ZZ, AAA, BBB Ultra band - 65 ~ 94, 100 ~ 135
Power source	AC 100~240 V 50/60 Hz
Power consumption	<60 W <1 W in standby mode
Audio power	3 W + 3 W internal speaker
S-Video input	Y:1 V(p-p), 75 ohm, negative sync C:0.286 V(p-p) (burst signal), 75 ohm
Video/audio input	Video:1 V(p-p), 75 ohm, negative sync Audio:500 mV(rms)
Component input	Y:1 V(p-p), 75 ohm, including sync Pr/Cr:±0.35 V(p-p), 75 ohm Pb/Cb:±0.35 V(p-p), 75 ohm Audio:500 mV(rms) Suggested resolutions:1080i, 720p, 480p, 480i
HDMI input	1 HDMI input terminal HDCP compliant E-EDID compliant Suggested scan rates:1080i, 720p, 480p, 480i
VGA input	D-Sub 15-pin terminal E-EDID compliant Suggested scan rates:640×480 /60 Hz, 800×600 /60 Hz, 1024×768 /60 Hz, 1440×900 /60 Hz, Audio input: Headphone mini-jack for stereo
Dimensions (W × H × D)	17.56 × 14.13 × 5.39 inches (44.6 × 35.9 × 13.7 cm)
Weight	8.82 lbs. (4 kg)
Accessories	Power cord User guide Remote control Batteries (2 AAA)

Legal notices

FCC Part 15

This device complies with Part 15 of the FCC Rules. Operation of this product is subject to the following two conditions: (1) this device may not cause harmful interference, and (2) this device must accept any interference received, including interference that may cause undesired operation.

This equipment has been tested and found to comply within the limits for a class B digital device, pursuant to Part 15 of the FCC Rules. These limits are designed to provide reasonable protection against harmful interference in a residential installation. This equipment generates, uses, and can radiate radio frequency energy and, if not installed and used in accordance with the instructions, may cause harmful interference to radio communications. However, there is no guarantee that interference will not occur in a particular installation. If this equipment does cause harmful interference to radio or television reception, which can be determined by turning the equipment off and on, the user is encouraged to try to correct the interference by one or more of the following measures:

- Reorient or relocate the receiving antenna.
- Increase the separation between the equipment and receiver.
- Connect the equipment into an outlet on a circuit different from that to which the receiver is connected.
- Consult the dealer or an experienced technician for help.

FCC warning

Changes or modifications not expressly approved by the party responsible for compliance with the FCC Rules could void the user's authority to operate this equipment.

Cables

Connections to this device must be made with shielded cables with metallic RF/EMI connector hoods to maintain compliance with FCC Rules and Regulations.



Manufactured under license from Dolby Laboratories. "Dolby" and the double-D symbol are trademarks of Dolby Laboratories.

One-year limited warranty

Dynex Products ("Dynex") warrants to you, the original purchaser of this new **DX-LCD19-09** ("Product"), that the Product shall be free of defects in the original manufacture of the material or workmanship for a period of one (1) year from the date of your purchase of the Product ("Warranty Period"). This Product must be purchased from an authorized dealer of Dynex brand Products and packaged with this warranty statement. This warranty does not cover refurbished product. If you notify Dynex during the Warranty Period of a defect covered by this warranty that requires service, terms of this warranty apply.

How long does the coverage last?

The Warranty Period lasts for one year (365 days) from the date you purchased the Product. The purchase date is printed on the receipt you received with the Product.

What does this warranty cover?

During the Warranty Period, if the original manufacture of the material or workmanship of the Product is determined to be defective by an authorized Dynex repair center or store personnel, Dynex will (at its sole option): (1) repair the Product with new or rebuilt parts; or (2) replace the Product at no charge with new or rebuilt comparable products or parts. Products and parts replaced under this warranty become the property of Dynex and are not returned to you. If service of products and parts are required after the Warranty Period expires, you must pay all labor and parts charges. This warranty lasts as long as you own your Dynex Product during the Warranty Period. Warranty coverage terminates if you sell or otherwise transfer the Product.

How to obtain warranty service?

If you purchased the Product at a retail store location, take your original receipt and the Product to the store you purchased it from. Make sure that you place the Product in its original packaging or packaging that provides the same amount of protection as the original packaging. If you purchased the Product from an online web site, mail your original receipt and the Product to the address listed on the web site. Make sure that you put the Product in its original packaging or packaging that provides the same amount of protection as the original packaging.

To obtain in-home warranty service for a television with a screen 25 inches or larger, call 1-888-BESTBUY. Call agents will diagnose and correct the issue over the phone or will have an Dynex-approved repair person dispatched to your home.

Where is the warranty valid?

This warranty is valid only to the original purchaser of the Product in the United States, Canada, and Mexico.

What does the warranty not cover?

This warranty does not cover:

- Customer instruction
- Installation
- Set up adjustments
- Cosmetic damage
- Damage due to acts of God, such as lightning strikes
- Accident
- Misuse
- Abuse
- Negligence
- Commercial use
- Modification of any part of the Product
- Plasma display panel damaged by static (non-moving) images applied for lengthy periods (burn-in).

This warranty also does not cover:

- Damage due to incorrect operation or maintenance
- Connection to an incorrect voltage supply
- Attempted repair by anyone other than a facility authorized by Dynex to service the Product
- Products sold as is or with all faults
- Consumables, such as fuses or batteries
- Products where the factory applied serial number has been altered or removed

REPAIR REPLACEMENT AS PROVIDED UNDER THIS WARRANTY IS YOUR EXCLUSIVE REMEDY. DYNEX SHALL NOT BE LIABLE FOR ANY INCIDENTAL OR CONSEQUENTIAL DAMAGES FOR THE BREACH OF ANY EXPRESS OR IMPLIED WARRANTY ON THIS PRODUCT, INCLUDING, BUT NOT LIMITED TO, LOST DATA, LOSS OF USE OF YOUR PRODUCT, LOST BUSINESS OR LOST PROFITS. DYNEX PRODUCTS MAKES NO OTHER EXPRESS WARRANTIES WITH RESPECT TO THE PRODUCT, ALL EXPRESS AND IMPLIED WARRANTIES FOR THE PRODUCT, INCLUDING, BUT NOT LIMITED TO, ANY IMPLIED WARRANTIES OF AND CONDITIONS OF MERCHANTABILITY AND FITNESS FOR A PARTICULAR PURPOSE, ARE LIMITED IN DURATION TO THE WARRANTY PERIOD SET FORTH ABOVE AND NO WARRANTIES, WHETHER EXPRESS OR IMPLIED, WILL APPLY AFTER THE WARRANTY PERIOD. SOME STATES, PROVINCES AND JURISDICTIONS DO NOT ALLOW LIMITATIONS ON HOW LONG AN IMPLIED WARRANTY LASTS, SO THE ABOVE LIMITATION MAY NOT APPLY TO YOU. THIS WARRANTY GIVES YOU SPECIFIC LEGAL RIGHTS, AND YOU MAY ALSO HAVE OTHER RIGHTS, WHICH VARY FROM STATE TO STATE OR PROVINCE TO PROVINCE.

Contact Dynex:

For customer service please call 1-800-305-2204

www.dynexproducts.com

Distributed by Best Buy Purchasing, LLC

7601 Penn Avenue South, Richfield, Minnesota, U.S.A. 55423-3645

© 2009 Best Buy Enterprise Services, Inc.

All rights reserved. DYNEX is a trademark of Best Buy Enterprise Services, Inc. Registered in some countries. All other products and brand names are trademarks of their respective owners.

DYNEX™

ENGLISH
08-1682

www.dynexproducts.com (800) 305-2204

Distributed by Best Buy Purchasing, LLC
7601 Penn Ave. South, Richfield, MN 55423 U.S.A.

© 2009 Best Buy Enterprise Services, Inc. All rights reserved.

DYNEX is a trademark of Best Buy Enterprise Services, Inc. Registered in some countries. All other products and brand names are trademarks of their respective owners.

Free Manuals Download Website

<http://myh66.com>

<http://usermanuals.us>

<http://www.somanuals.com>

<http://www.4manuals.cc>

<http://www.manual-lib.com>

<http://www.404manual.com>

<http://www.luxmanual.com>

<http://aubethermostatmanual.com>

Golf course search by state

<http://golfingnear.com>

Email search by domain

<http://emailbydomain.com>

Auto manuals search

<http://auto.somanuals.com>

TV manuals search

<http://tv.somanuals.com>