



# PH10

## PAGING HORN

### DESCRIPTION

The PH10 is a weather-resistant paging horn designed for indoor or outdoor fixed installations.

The PH10 is supplied with an integral 70/100V line transformer rated to a maximum of 10 watts. Power is adjustable by means of a recessed rotary switch on the back of the horn, and allows selection of 5, 2.5, 1.25, 0.625, and OFF for 70.7V operation, and 10, 5, 2.5, 1.25, and OFF for 100V operation. A sixth position is provided for low-impedance operation at 10W into 8 ohms.

The paging horn assembly is shipped with an adjustable mounting bracket for easy installation and aiming, and an attached color-coded speaker cable. It is constructed of high-impact ABS plastic with a light grey finish.



### PH10 DIMENSIONS

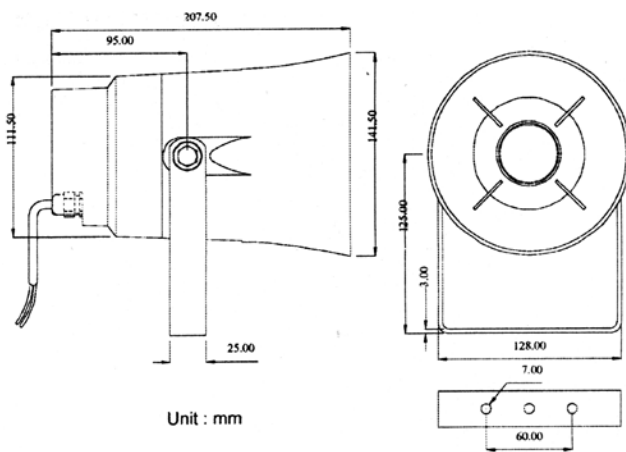

### Features

- High-efficiency paging horn
- Weather-resistant to withstand demanding environmental conditions
- Built-in multi-tap constant voltage transformer for 70.7 V or 100 V distributed systems
- Bypass mode for low-impedance operation into 8 ohms
- Lightweight, UV/weather resistant, high-impact ABS plastic construction
- Integrated cable strain relief
- Stainless steel mounting bracket

### Applications

- Indoor/Outdoor Voice Paging
- Background Music
- Tone Signaling
- Boats
- Mobile Vehicle
- Security

### SPECIFICATIONS

#### SYSTEM

Freq. Range (-10 dB):	380 Hz-9 kHz
Freq. Range (-20 dB):	340 Hz-11 kHz
Dispersion @ 1 kHz/4 kHz:	180°/45°
SPL (1W):	106 dB @ 1m
Rated Maximum SPL (10W):	116 dB @ 1m
System Input Power Rating:	10W rms long term
Transformer Taps	
70V:	5W, 2.5W, 1.25W, 0.625W, OFF, 8Ω
100V:	10W, 5W, 2.5W, 1.25W, OFF, 8Ω
Impedance:	1 kΩ @ 10W, 2 kΩ @ 5W, 4 kΩ @ 2.5W,
	8 kΩ @ 1.25W, OFF, 8Ω
Water Protection:	IEC529 and IP66 (protected from dust and strong jets of water)

#### PHYSICAL

Material:	High-impact ABS
Color/Finish:	Light grey (RAL 7035)
Dimensions (Diameter x Length):	5.6 in/142 mm x 8.2 in/208 mm
Net Weight:	3.8 lb/1.7 kg
Mounting:	U-type stainless steel bracket

### PH10 FREQUENCY RESPONSE

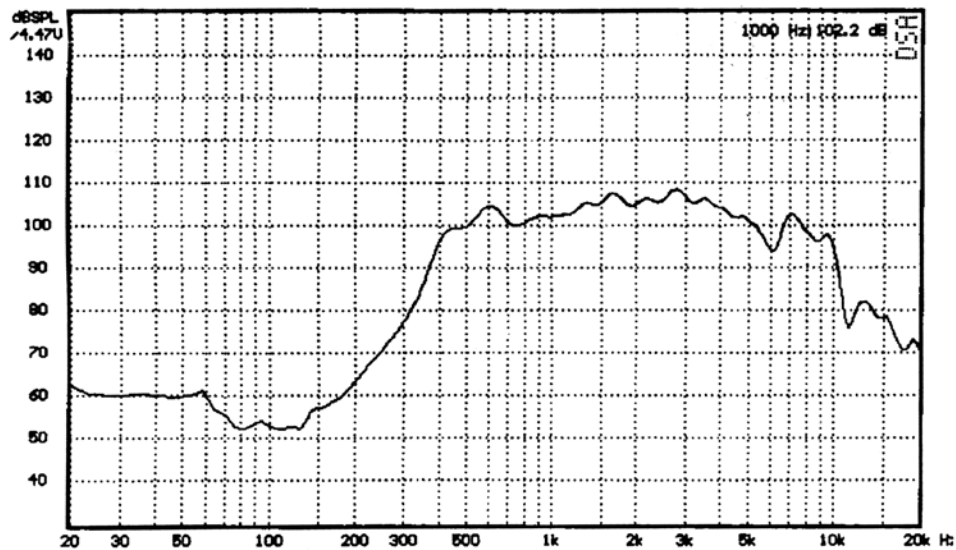

## Free Manuals Download Website

<http://myh66.com>

<http://usermanuals.us>

<http://www.somanuals.com>

<http://www.4manuals.cc>

<http://www.manual-lib.com>

<http://www.404manual.com>

<http://www.luxmanual.com>

<http://aubethermostatmanual.com>

Golf course search by state

<http://golfingnear.com>

Email search by domain

<http://emailbydomain.com>

Auto manuals search

<http://auto.somanuals.com>

TV manuals search

<http://tv.somanuals.com>