

VR-CM50 CONSOLE SYSTEM INSTALLATION GUIDE

Second Printing

February 1996

Supersedes 004-3039-274 May 1995

VR-CM50 CONSOLE SYSTEM INSTALLATION GUIDE

Copyright© 1995 by the E.F. Johnson Company

The E.F. Johnson Company designs and manufactures two-way radio equipment to serve a wide variety of communications needs. Johnson produces equipment for the mobile telephone and land mobile radio services which include business, industrial, government, public safety, and personal users. In addition, Johnson designs and manufactures electronic components used in communications equipment and other electronic devices.

LAND MOBILE PRODUCT WARRANTY

The manufacturer's warranty statement for this product is available from your product supplier or from the E.F. Johnson Company, 299 Johnson Avenue, Box 1249, Waseca, MN 56093-0514. Phone (507) 835-6222.

WARNING

This device complies with Part 15 of the FCC rules. Operation is subject to the condition that this device does not cause harmful interference. In addition, changes or modification to this equipment not expressly approved by E. F. Johnson could void the user's authority to operate this equipment (FCC rules, 47CFR Part 15.19).

DO NOT allow the antenna to come close to or touch, the eyes, face, or any exposed body parts while the radio is transmitting.

DO NOT operate the radio near electrical blasting caps or in an explosive atmosphere.

DO NOT operate the radio unless all the radio frequency connectors are secure and any open connectors are properly terminated.

DO NOT allow children to operate transmitter equipped radio equipment.

SAFETY INFORMATION

Proper operation of this radio will result in user exposure below the Occupational Safety and Health Act and Federal Communication Commission limits.

The information in this document is subject to change without notice.

TABLE OF CONTENTS

1 PRE-INSTALLATION INFORMATION

1.1 RECEIVING INFORMATION	1-1
VISIBLE LOSS OR DAMAGE	1-1
CONCEALED LOSS OR DAMAGE	1-1
PACKING LIST	1-1
UNPACKING THE SHIPMENT	1-1
TOOLS REQUIRED	1-2

2 CENTRAL PROCESSOR PACKAGE INSTALLATION

2.1 LOCATION OF THE CENTRAL PROCESSOR PACKAGE (CPP)	2-1
2.2 ASSEMBLY OF THE CENTRAL PROCESSOR PACKAGE (CPP) CABINETY	2-1
2.3 CONNECTION OF THE CENTRAL PROCESSOR PACKAGE CABLES	2-3
CABLE ROUTING	2-3
2.4 MOUNTING OF SURGE ARRESTOR BOXES AND GROUND BRACKET	2-4
PLACEMENT OF SURGE ARRESTOR BOXES	2-4
WALL OR PANEL BOARD INSTALLATION	2-4
2.5 GROUNDING THE SYSTEM	2-5
2.6 GROUNDING INSTALLATION	2-6
2.7 CPP I/O PANELS	2-7
2.8 SAMPLE CUSTOMER DATA SHEETS	2-8
2.9 WIRING OF SURGE ARRESTOR BOXES	2-11
2.10 DISPATCH POSITION CONNECTIONS	2-12
2.11 VOTER SYSTEM CONNECTIONS	2-12
2.12 LOGGING RECORDER CONNECTIONS	2-12
2.13 PRINTER INSTALLATION	2-13
2.14 MODEM INSTALLATION	2-13
2.15 CONNECTION TO AUXILIARY CONTROL FUNCTIONS (Standard Cabinet)	2-13
2.16 CONNECTION TO AUXILIARY CONTROL FUNCTIONS (14 Card Central Cabinet)	2-15
2.17 PA SYSTEM FEED	2-16
2.18 CONNECTIONS TO AC POWER	2-16

3 CABINETY ASSEMBLY FOR CRT CONSOLE SYSTEMS

3.1 INTRODUCTION	3-1
3.2 TOOLS REQUIRED	3-1
3.3 CONSOLE ARRANGEMENT	3-1
3.4 MAIN CONSOLE ASSEMBLY	3-2
3.5 CONSOLE LEVELING	3-2
3.6 FORMICA WRITING SURFACE ARRANGEMENT	3-3
3.7 WRITING SUPPORT RAIL MOUNTING	3-3
3.8 ATTACHING THE FORMICA WRITING SURFACE	3-5
3.9 FORMICA WRITING SURFACE AND TRIM	3-6
3.10 CABINETY OPTIONS	3-6
STABILIZER KIT (Option 1)	3-6
ADJUSTABLE KEYBOARD SEAT (Option 2)	3-7
UNIVERSAL KEYBOARD DRAWER MOUNTING (Option 3)	3-7
UNIVERSAL PENCIL DRAWER MOUNTING (Option 4)	3-8
TYPEWRITER EXTENSION ASSEMBLY (Option 5)	3-8
PIE SUPPORT RAIL MOUNTING (Option 6)	3-8
CRT MONITOR SHELF - FXM-192 (Option 7)	3-9

TABLE OF CONTENTS (CONT.)

4 CRT-BASED ELECTRONICS ASSEMBLY PART I

4.1	INTRODUCTION.....	4-1
4.2	INSTALL THE PC/UPS SLIDE TRAY.....	4-1
4.3	CRT INTERFACE PROCESSOR (CIP).....	4-1
	INSTALL THE CIP POWER SUPPLY.....	4-1
	INSTALL THE CRT INTERFACE PROCESOR (CIP) TRAY.....	4-2

5 CRT-BASED ELECTRONICS ASSEMBLY PART II

5.1	INTRODUCTION.....	5-1
5.2	INSTALL THE PC AND UPS.....	5-1
5.3	CONNECT THE PC CPU AND PC UPS POWER CORDS.....	5-1
5.4	CONNECT THE CRT INTERFACE PROCESSOR (CIP) TRAY CABLES.....	5-2
5.5	INSTALL THE CRT MONITOR.....	5-3
	CRT MONITOR CONNECTIONS.....	5-3
	ADDITIONAL CONNECTION FOR A 17 " OR 21 " IDEK MONITOR.....	5-3
5.6	INSTALL CRT TOUCHSCREEN (Option TDV-OP492).....	5-3
	MOUNT TABS.....	5-3
	INSTALL THE TOUCHSCREEN.....	5-3
	CONNECT THE TOUCHSCREEN CABLES.....	5-3
5.7	INSTALL CRT TRACKBALL OPTION/MOUSE OPTION.....	5-4
5.8	INSTALL HEADSET JACK (Options TDV-OP406, 407, 409).....	5-4
5.9	INSTALL SECOND VOLUME CONTROL KNOB.....	5-4
5.10	SET UP AND OPERATION OF THE HEADSET JACK.....	5-5
5.11	CONNECTING A TELEPHONE INSTRUMENT TO THE TELCO INTERFACE.....	5-5

6 EQUIPMENT CHECK-OUT AND ADJUSTMENTS

6.1	INITIAL POWER-UP AND CHECK-OUT.....	6-1
6.2	CPP ADJUSTMENTS.....	6-2
6.3	CONSOLE ADJUSTMENTS.....	6-2
6.4	ALIGN THE CRT TOUCHSCREEN WITH THE PC COMPUTER.....	6-3
6.5	AFTER SYSTEM CHECK-OUT.....	6-4

LIST OF FIGURES

1-1	HARDWARE INCLUDED FOR INSTALLATION AND ASSEMBLY.....	1-2
2-1	REAR VIEW - JOINING TWO CPU CABINETS.....	2-2
2-2	CPU CABINET CABLE CONNECTIONS.....	2-3
2-3	MOUNTING SURGE ARRESTOR BOXES AND GROUND BRACKET.....	2-4
2-4	STAR GROUNDING CONFIGURATION.....	2-5
2-5	COMMON GROUND BRACKET ASSEMBLY.....	2-6
2-6	CPP I/O PANELS.....	2-7
2-7	I/O CONNECTOR PANEL ASSIGNMENTS.....	2-8
2-8	RTL I/O PANEL ASSIGNMENTS.....	2-9
2-9	VOTING COMPARATOR DISPLAY/CONTROL MODULE.....	2-9
2-10	LOGGING RECORDER.....	2-10
2-11	AUXILIARY CONTROL RELAY ASSIGNMENTS.....	2-10
2-12	SURGE ARRESTOR BOX WIRING.....	2-11
2-13	CPU RELAY PANEL.....	2-14

TABLE OF CONTENTS (CONT.)

2-14	14 CARD RELAY PANEL	2-15
2-15	CPP POWER SUPPLY	2-16
3-1	SAMPLE CONSOLE LAYOUT	3-1
3-2	WRITING SUPPORT MOUNTING HOLES	3-2
3-3	ASSEMBLY OF CONSOLE SECTIONS	3-2
3-4	FORMICA SURFACE ARRANGEMENT	3-3
3-5	LEVELING THE CONSOLE	3-3
3-6	WRITING SUPPORT RAIL MOUNTING	3-4
3-7	CTP TRAY	3-5
3-8	JOINING FORMICA	3-5
3-9	SECURING THE FORMICA WRITING SURFACE	3-5
3-10	FORMICA WRITING SURFACE AND TRIM	3-6
3-11	STABILIZER KIT	3-7
3-12	ADJUSTABLE KEYBOARD SEAT	3-7
3-13	KEYBOARD DRAWER MOUNTING	3-7
3-14	UNIVERSAL PENCIL DRAWER MOUNTING	3-8
3-15	TYPEWRITER EXTENSION ASSEMBLY	3-8
3-16	PIE SUPPORT RAIL MOUNTING	3-9
3-17	INSTALLING TINNERMAN CLIPS	3-9
3-18	CRT MONITOR SHELF	3-10
4-1	PC AND UPS SLIDE TRAY ASSEMBLY	4-1
4-2	CIP POWER SUPPLY	4-2
4-3	CIP TRAY WITH MICROPHONE	4-3
5-1	CPU AND UPS POWER CONNECTIONS	5-1
5-2	CIP POWER SUPPLY LINE TERM BOARD - A1709230	5-2
5-3	TOUCHSCREEN INSTALLATION	5-3
5-4	CABLE CONNECTION TO CIP PS	5-3
5-5	HEADSET JACK	5-4
5-6	CIP BOARD	5-4
5-7	CONNECTOR HEADSET	5-5
5-8	TELCO CONNECTION TO CIP PS	5-5

LIST OF TABLES

1-1	SAMPLE PACKING LIST	1-1
2-1	CPU CABINET HARDWARE	2-1
2-2	I/O PANEL REPORT	2-8
2-3	STANDARD COLOR CODE ASSIGNMENTS	2-12
3-1	MONITOR SHELF HARDWARE	3-10
4-1	PC UPS OPTION NUMBERS	4-1
4-2	SLIDE TRAY HARDWARE	4-1
4-3	POWER SUPPLY HARDWARE	4-1
4-4	CIP TRAY HARDWARE	4-2
4-5	CIP TRAY CABLE CONNECTIONS	4-3
5-1	PC UPS OPTIONS	5-1
5-2	CRT CABLE CONNECTIONS	5-2
5-3	VOLUME CONTROL HARDWARE	5-4

SECTION 1 PRE-INSTALLATION INFORMATION

1.1 RECEIVING INFORMATION

IMPORTANT

This merchandise was carefully packed and thoroughly inspected before leaving our factory. Responsibility for its safe delivery was assumed by the carrier upon acceptance of the shipment. Claims for loss or damage sustained in transit must therefore be made upon the carrier as follows:

1.1.1 VISIBLE LOSS OR DAMAGE

Any external evidence of loss or damage must be noted on the freight bill or express receipt and signed by the carrier's agent. Failure to adequately describe such external evidence of loss or damage may result in the carrier refusing to honor a damage claim. The form required to file such a claim is supplied by the carrier.

1.1.2 CONCEALED LOSS OR DAMAGE

Concealed loss or damage means; loss or damage that is not apparent until the merchandise has been unpacked. The contents may be damaged in transit due to rough handling even though the carton or cabinet may not show external damage. When the damage is discovered upon unpacking, you must make a written request for inspection by the carrier's agent within 15 days of the delivery date. Then file a claim with the carrier since such damage is the carrier's responsibility.

It is a requirement of certain OEM vendors that equipment returned for repair **must be shipped in its original carton**. This specifically applies to the Moni-

tor, PC and UPS units for CRT-based consoles. You are strongly advised to save at least one shipping carton for each of these devices in the event a return for repair is needed.

You as the consignee, are responsible for filing any claims for loss or damage. E.F. Johnson will assist you in establishing the value of the claim after you have filed the claim with the carrier. Call the Customer Service Department at 1-800-328-3911 for further assistance.

1.1.3 PACKING LIST

Since this product is custom designed to meet our customer's needs, it is not practical to pack our products in any specific pattern.

As each loose item (see Note below) is packed it is noted on the Packing List (see Table 1-1).

1.1.4 UNPACKING THE SHIPMENT

As each item is removed from the container, please check it against the Packing List. If there are any discrepancies, please contact Customer Service, 1-800-328-3911, within 7 days of receipt. E.F. Johnson cannot be held responsible for discrepancies beyond this 7 day period.

Note: Commercial items packaged in the original manufacturer's container(s) are considered loose items. Items packaged within their containers, by the manufacturer (power cords, etc.), are not considered loose items and are not listed on the E.F. Johnson Packing List.

Table 1-1 SAMPLE PACKING LIST

Container Number	Part Number	Description	Quantity
1	A100960	Headset Jack Assy	2
...

1.1.5 TOOLS REQUIRED







The following tools are needed for the mechanical assembly and installation of the VR-CM50 Console System:

- 1/4" Flat Blade Screwdriver
- #1 Phillips Screwdriver
- #2 Phillips Screwdriver
- 7/16" Open End Wrench
- 3/8" Nut Driver
- 3/16" Ball Point Driver
- 3/8" Square Drive 3/16" Hex Bit

If you are installing cabinetry, the tools required for those assemblies are listed in Section 3.

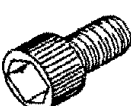
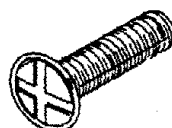
- 3/16" Hex Key
- 3/8" Square Drive 7/16" Socket
- 3/8" Drive Ratchet Wrench
- Wire Strippers
- Carpenter's Level
- Hand Terminal Crimp Tool - "Champ" Tool

SCREWS

-  Flakeboard
-  12-24x1/2 Pan Head Philips
-  12-24x1/2 Socket Head
-  12-24x1 Truss Head Philips
-  10-32x1/2 Pan Head Philips
-  6-32x1/2 Pan Head Philips
-  4-40x1/2 Pan Head Philips

OTHER







-  1/4-20x3/4 Hex Bolt
-  1/4-20 Keps Nut
-  10x24x1/2 Hex Bolt
-  Tinnerman Clip
-  #12 Black Nylon Washer
-  2 1/2" Bushing Snap Ring
-  Microphone Trim Plate With Hole
-  Black Trim Plate

Figure 1-1 HARDWARE INCLUDED FOR INSTALLATION AND ASSEMBLY

SECTION 2 CENTRAL PROCESSOR PACKAGE INSTALLATION

2.1 LOCATION OF THE CENTRAL PROCESSOR PACKAGE (CPP)

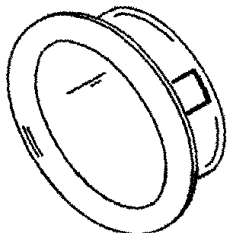
In selecting a location for the Central Processor Package (CPP) equipment cabinet, the following criteria should be considered:

1. Avoid locations which are subject to high ambient temperatures, excessive moisture, flooding, excessive dust or infestation by insects or small animals.
2. The cabinet must be placed in an indoor location having a floor area large enough to allow access to both the front and rear of the cabinet. The minimum cabinet size is 21" wide by 26" deep. In addition, wall space will be required for the common ground bracket, surge arrestor box(es) and any additional RTL punch block(s).
3. A single, 120 VAC, 15/20 amp dedicated branch circuit is required for CPPs of 60 card capacity or less. Two such branch circuits are required for packages equipped with 60 to 120 cards. Systems ordered with options TDM-OP200/E, /GB, /I and /NZ require 230 VAC circuits. If the building is equipped with an emergency generator, the CPP branch circuits should be part of the emergency power system.
4. An earth ground bond must be provided. A continuous copper cold water pipe or driven copper ground rod are suitable grounds. Electrical conduit, steam lines, sprinkler system lines, utility mains or building steel may not be used as ground bonds. *Note: Verify the ground integrity yourself. It is risky to blindly trust grounds used by others.*
5. The cable run to any console location may not exceed 4000 feet, using E.F. Johnson-provided cable. If the console is located in a different building or if the cable route places its proximity to other electrical lines that can induce interference, the use of a Remote Interface Adapter (RIA) is required.
6. In placement of the cabinet, the front door of the enclosure must be readily accessible for service.

7. A connection to an outside telephone line is required for diagnostic modem access. If a dedicated modem line cannot be provided, an administrative line or a phone patch line can be used by routing the line through the modem. Programming the modem to auto-answer after several rings, will allow the line to be used for normal voice operation as well as CPP diagnostics.
8. Mounting space will be required for the system diagnostic printer (TDM-OP205). If the CPP is housed in a 60" cabinet, the printer can be placed on top of the CPP. If the CPP is housed in a 88" cabinet, a shelf must be provided for the printer. The printer is supplied with a table-top stand which provides paper supply storage and an output tray. Do not attempt to mount the printer inside the CPP cabinet.

2.2 ASSEMBLY OF THE CENTRAL PROCESSOR PACKAGE (CPP) CABINETRY

If the CPP is housed in a single cabinet (30 cards or less in a 60" cabinet, 60 cards or less in a 88" cabinet), no field assembly is required. If the CPP requires two or more cabinets, each cabinet section will be shipped separately to facilitate handling. Assembly of the cabinets is illustrated below in Figure 2-1. Be sure to install all of the required hardware; do not omit any bolts or lockwashers.

The hardware in Table 2-1 is included in Assembly A2809201 for joining 2 - 60" CPU Cabinets and Assembly A2809301 for joining 2 - 88" CPU Cabinets:

Table 2-1 CPU CABINET HARDWARE

Qty.	Part No.	Description
Joining 2 - 60" CPU Cabinets		
6	28011H0B2012	1/4"-20 Hex Bolt
6	280211082041	1/4"-20 Keps Nut
2	240B25312420	2.5" Bushing Snap Ring
Joining 2 - 88" CPU Cabinets		
8	28011H0B2012	1/4"-20 Hex Bolt
8	280211082041	1/4"-20 Keps Nut
2	240B25312420	2.5" Bushing Snap Ring

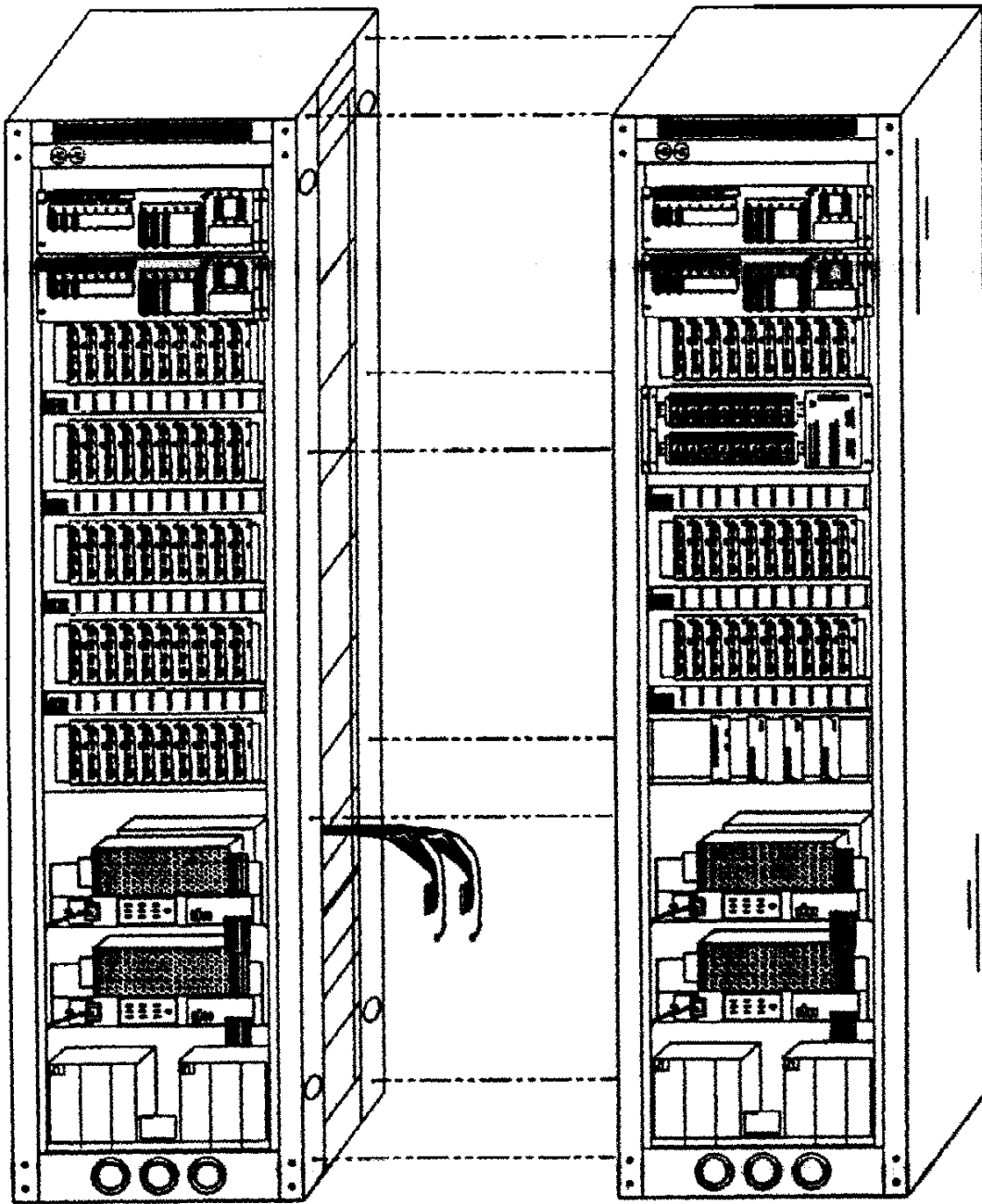

Figure 2-1 REAR VIEW - JOINING TWO CPU CABINETS

2.3 CONNECTION OF THE CENTRAL PROCESSOR PACKAGE CABLES

When multiple CPP cabinets are required, the system layout will have been designed to minimize the cabling needed between cabinets. At minimum, it will be necessary to connect the ribbon cables from the Inter-Cabinet Repeater (ICR) cards in the first cabinet, to the backplanes and power supplies in the expansion cabinets. Depending on the size of the CPP, the cables are marked with either RED DOTS or GREEN DOTS.

Connect the cables marked with a RED dot to the Line Terminator Board, which is also marked with a RED dot. Perform the same procedure if the cables are marked with GREEN dots (see Figure 2-2).

In some cases, it may be necessary to connect I/O ribbon cables or intercabinet mute wiring. Instructions for these details are unique to each system and

will be found in a document titled "Installation Notes" at the front of the "Customer Data" Section in Volume 1 of the VR-CM50 Console Service Manual.

2.3.1 CABLE ROUTING

60" CPP cabinets are designed for cable feed from the bottom of the cabinet.

80" CPP cabinets are designed to accept cable feeds from either the top or the bottom of the cabinet. 88" CPP cabinets are shipped with the assumption that the cables will feed from the top or from beneath the floor. If cable access through the bottom rear cowl is desired, remove the black hole plugs from the cowl and exchange them with the cable bushings in the top vent panel.

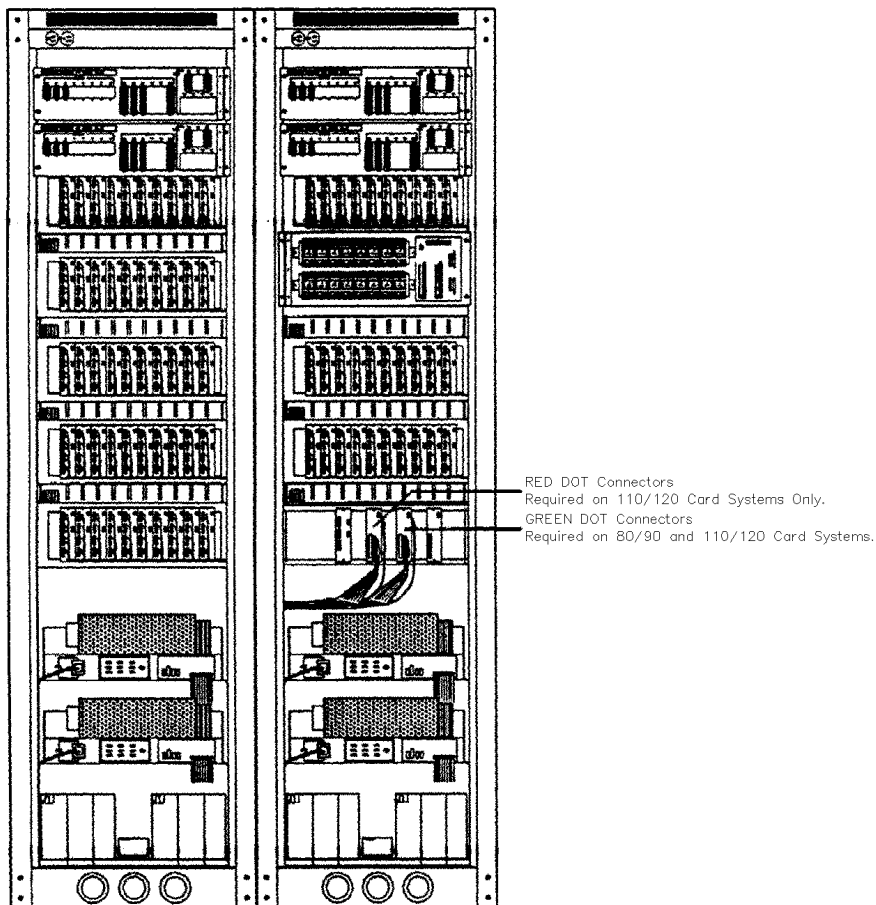

Figure 2-2 CPU CABINET CABLE CONNECTIONS

2.4 MOUNTING OF SURGE ARRESTOR BOXES AND GROUND BRACKET

2.4.1 PLACEMENT OF SURGE ARRESTOR BOXES

The surge arrestor box(es) may be mounted directly on a wall or on a plywood board at a location near the central equipment cabinet. (Be sure the ground lug is on top).

Figure 2-3 gives a general idea of how the Surge Arrestor Boxes would appear on a typical panel board complete with the common copper ground bracket assembly.

2.4.2 WALL OR PANEL BOARD INSTALLATION

Use 1/4" diameter screws (not furnished) to attach the surge arrestor boxes and the common ground bracket assembly to the wall. Wall mount keyholes (see Figure 2-3) are provided on the surge arrestor boxes. If the wall is of masonry construction, again, the use of a plywood sub-panel is recommended.

CAUTION

DO NOT mount with the ground lug on the bottom.

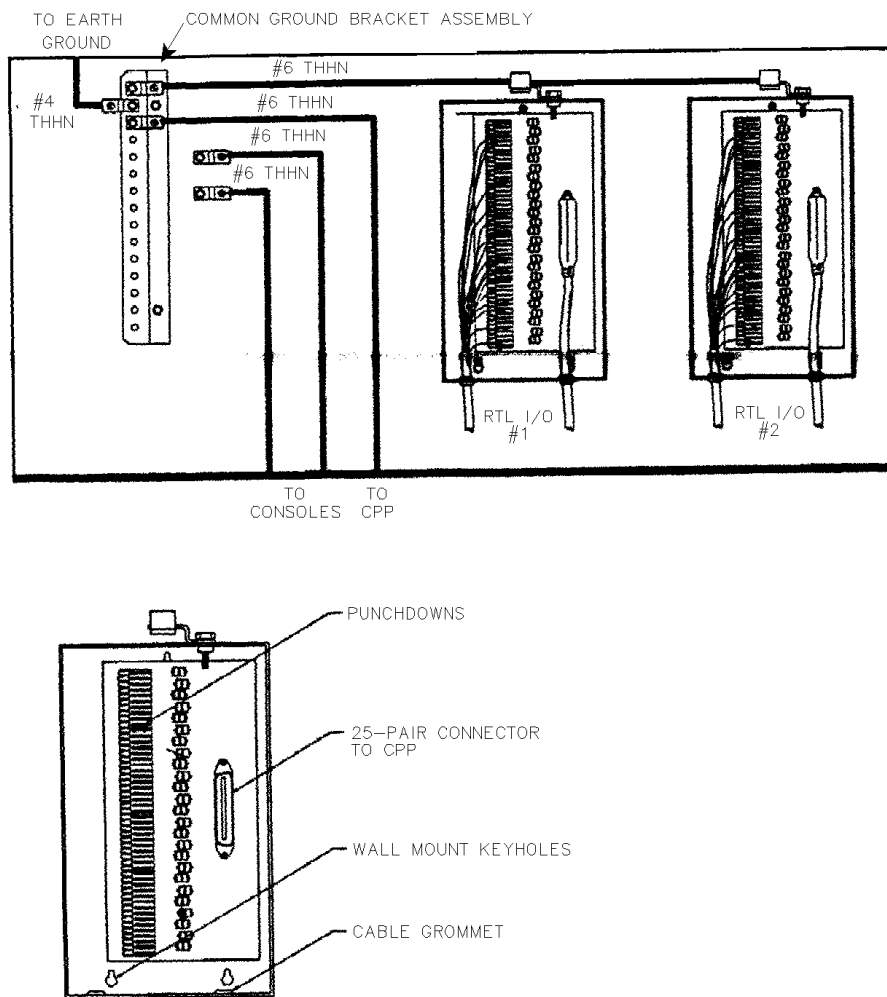

Figure 2-3 MOUNTING SURGE ARRESTOR BOXES AND GROUND BRACKET

2.5 GROUNDING THE SYSTEM

Proper grounding is the single most important consideration in installing the system. Poor or incorrect grounding can lead to unpredictable and erratic performance problems, damage to system components in the event of lightning or power surges and injury to personnel in extreme cases.

The VR-CM50 uses a STAR GROUNDING SYSTEM (below) in which each console is individually bonded to a common point at the CPP using a #6 insulated wire. Connectivity instructions with exploded views are continued on the following pages.

IMPORTANT

Ground the system before connecting any radio tie lines or AC power to the system.

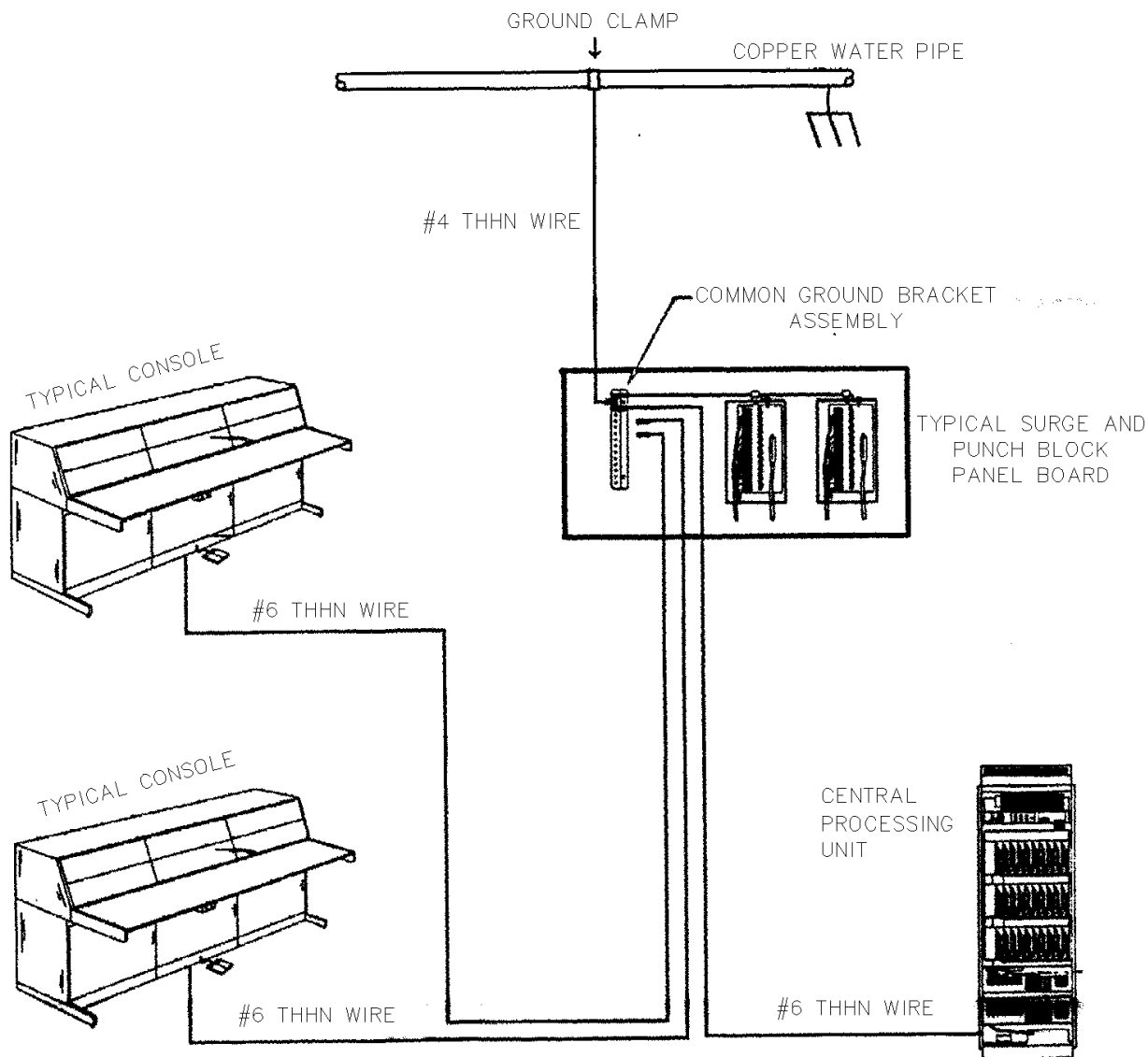

Figure 2-4 STAR GROUNDING CONFIGURATION

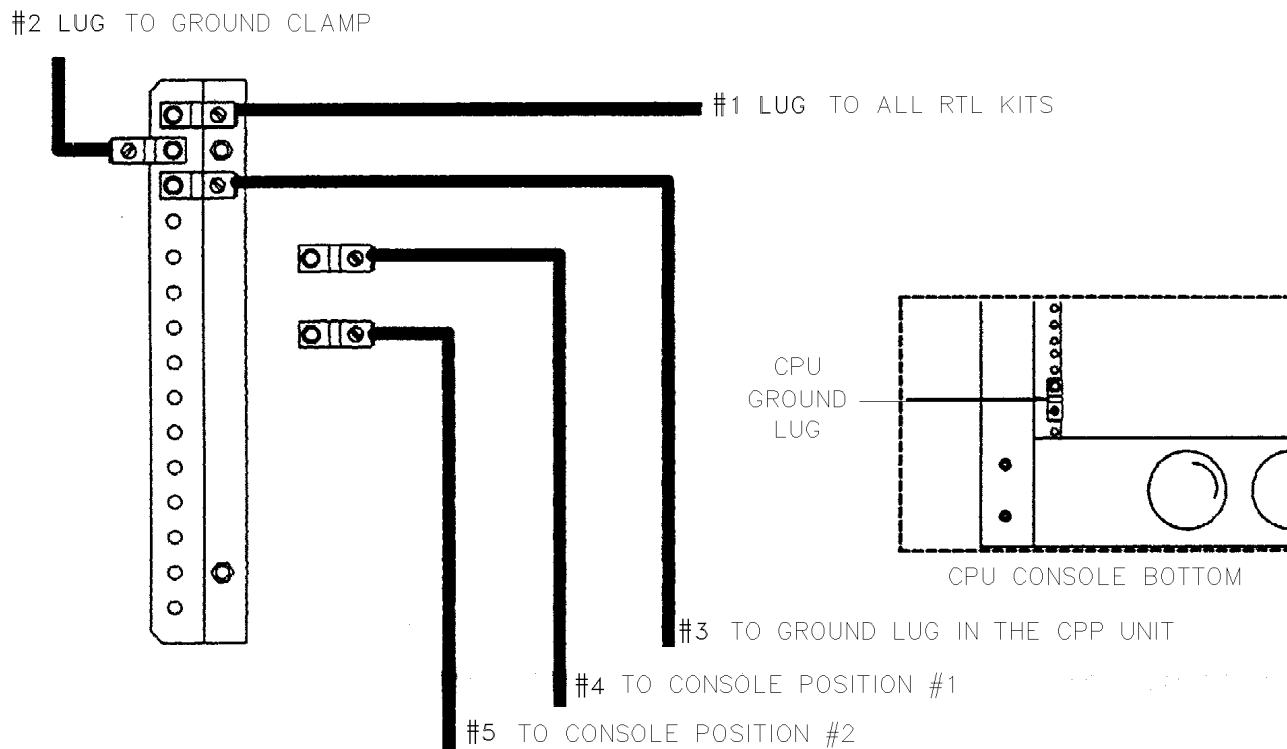

Figure 2-5 COMMON GROUND BRACKET ASSEMBLY

2.6 GROUNDING INSTALLATION

#1 Lug

Connect a #6 THHN bare ground wire to the TOP RIGHT (first) copper lug on the common ground bracket assembly to all RTL kits (make this by taking a length of the #6 THHN wire and stripping it). If multiple surge arrestor boxes are used, run the #6 THHN wire through the lugs of all boxes in a straight line. Tighten all clamps securely using the proper size screwdriver (1/4" flatblade).

#2 Lug

It is very important to connect the earth ground wire to lug #2, the lug opposite the CPP Cabinet lug and RTL kits lugs. Refer to Figure 2-5 for a correct

placement of the connections on the common ground bracket assembly. Use #4 THHN wire to connect to the ground clamp.

#3 Lug

Connect a #6 THHN wire to lug #3 (third from top) on the common ground bracket assembly to the ground lug in the CPP cabinet. Refer to Figure 2-5 for the location of the ground lug in the CPP cabinet.

#4, #5 Lug

Connect a #6 THHN ground wire from lugs 4, 5, etc. of the ground bracket assembly to the ground lug on each console position. A ground lug and hardware has been furnished with the cable kit for each console.

2.7 CPP I/O PANELS

CPPs with a capacity of twenty or more cards will have one or more CPP I/O panels as shown in Figure 2-6. If there is more than one I/O panel, each panel is numbered. The I/O panels are hinged to allow easy access to the rear of the card cages. In routing the I/O cables, all wiring should be dressed from the hinge side of the panel.

Fourteen card CPPs have a single I/O panel as shown in Fig. 2-9. This panel is at the lower left side of the cabinet as viewed from the rear. This panel is fixed in position - no rear access is required.

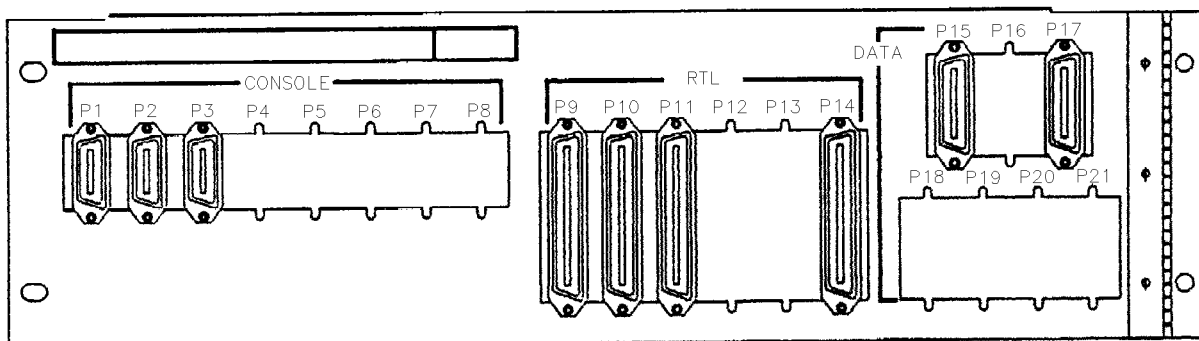

TO DISPATCH POSITIONS TO RADIO TIE LINES TO DATA TERMINALS
 20 (or more) CARD CPP I/O PANEL

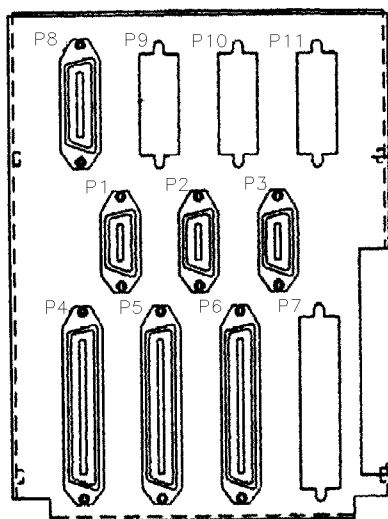

14 CARD SINGLE I/O PANEL

Figure 2-6 CPP I/O PANELS

2.8 SAMPLE CUSTOMER DATA SHEETS

The Customer Data Sheets which are included in the VR-CM50 Console Service Manual, Volume 1, will detail the connector and pair assignments for all I/O functions. Connector assignments are defined in a report titled I/O CONNECTOR PANEL ASSIGNMENTS located behind the T/R CHANNEL CONTROL PROGRAMMING sheets. If there is more than one connector I/O panel, a report will be provided for each panel.

An illustration of the I/O Connector Panel Assignments report is shown in SAMPLE 1 below. Separate reports for RTL I/O Lines are shown as

SAMPLES 2, 3 and 4. A sample Auxiliary Control Relay Assignments report is shown as SAMPLE 5. These can be found on the following pages.

A separate report is provided for each I/O Connector Panel.

Table 2-2 I/O PANEL REPORT

I/O Conn. Panel Report	14 Card CPP	20+ Card CPP
Dispatch position I/O Lines	P1-P3	P1-P8
RTL I/O Lines	P4-P7	P9-P14
Data I/O Lines	P8-P11	P15-P21

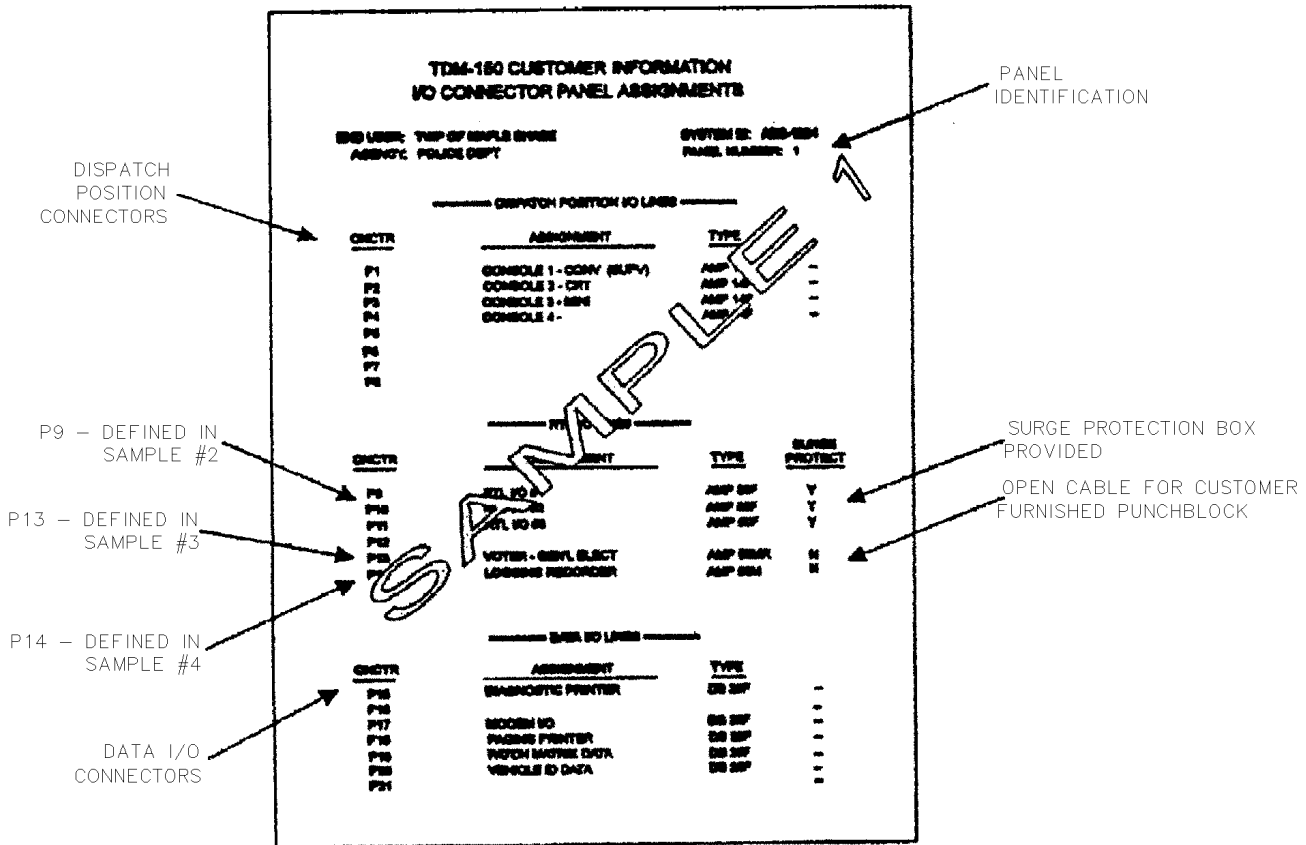

Figure 2-7 I/O CONNECTOR PANEL ASSIGNMENTS

TDM-150 CUSTOMER INFORMATION
RTL I/O PANEL ASSIGNMENTS

END USER: TWP OF MAPLE BRIDGE SYSTEM ID: ABC004
AGENCY: POLICE DEPT

PANEL: 1
CONNECTOR: P9
FUNCTION: RTL I/O
TYPE: AMP SW SURGE PROTECT: Y

PAIR	COLOR	TRAY	SLOT	DESCRIPTIONS	FUNCTION
1	WHITE/BLU	2	1	LEAD	POLICE SW CNTL
2	WHITE/GRN	2	1	L1A.1	POLICE 4W FX
3	WHITE/GRN	--	--	--	--
4	WHITE/GRN	--	--	--	--
5	WHITE/BLA	2	1	SP4B	POLICE M LEAD
6	RED/BLU	2	2	LEAD	FIRE SW CNTL
7	RED/GRN	2	2	L1A.2	FIRE 4W FX
8	RED/GRN	--	--	--	--
9	RED/GRN	--	--	--	--
10	RED/BLA	2	2	SP4B	FIRE M LEAD
11	BLU/BLU	2	3	LEAD	MUNICIPAL SW CNTL
12	BLU/GRN	--	--	L1A.2	MUNICIPAL 4W FX
13	BLU/GRN	--	--	--	--
14	BLU/GRN	--	--	--	--
15	BLU/BLA	2	3	SP4B	MUNICIPAL M LEAD
16	GRN/BLU	2	3	LEAD	RESOLVE SW CNTL
17	GRN/GRN	2	3	L1A.2	RESOLVE 4W FX
18	GRN/GRN	--	--	--	--
19	GRN/GRN	--	--	--	--
20	GRN/BLA	2	3	SP4B	RESOLVE M LEAD
21	GRN/BLU	2	3	LEAD	SPEN SW CNTL
22	GRN/GRN	2	3	L1A.2	SPEN 4W FX
23	GRN/GRN	--	--	--	--
24	GRN/GRN	--	--	--	--
25	GRN/BLA	2	3	SP4B	SPEN M LEAD

BRIDGE WARE

Figure 2-8 RTL I/O PANEL ASSIGNMENTS

TDM-150 CUSTOMER INFORMATION
VOTING COMPARATOR DISPLAY/CONTROL MODULE --
GENERAL ELECTRIC FORMAT BY FUNCTION

END USER: TWP OF MAPLE BRIDGE SYSTEM ID: ABC004
AGENCY: POLICE DEPT

CHANNEL ID: POLICE 1 ALARM 5-0
ID PANEL: 1 TYPE: AMP SW

CONNECTOR: P13

FUNCTION	TERMINAL	DESCRIPTIONS	PK NO	ALARM COMP
SEL SW SITE 1	1	HEADQUARTERS	20	010
SEL SW SITE 2	2	FLA 1	21	011
SEL SW SITE 3	3	NORTH TOWER	22	012
SEL SW SITE 4	4	SOUTH TOWER	23	013
SEL SW SITE 5	5	SOUTH END	24	014
SEL SW SITE 6	6	SOUTH END	25	015
SEL SW SITE 7	7	HEADQUARTERS	26	016
SEL SW SITE 8	8	FLA 1	27	017
SEL SW SITE 9	9	NORTH TOWER	28	018
SEL SW SITE 10	10	SOUTH TOWER	29	019
SEL SW SITE 11	11	SOUTH END	30	020
SEL SW SITE 12	12	SOUTH END	31	021
SEL SW SITE 13	13	HEADQUARTERS	32	022
SEL SW SITE 14	14	FLA 1	33	023
SEL SW SITE 15	15	NORTH TOWER	34	024
SEL SW SITE 16	16	SOUTH TOWER	35	025
SEL SW SITE 17	17	SOUTH END	36	026
SEL SW SITE 18	18	SOUTH END	37	027
SEL SW SITE 19	19	HEADQUARTERS	38	028
SEL SW SITE 20	20	FLA 1	39	029
SEL SW SITE 21	21	NORTH TOWER	40	030
SEL SW SITE 22	22	SOUTH TOWER	41	031
SEL SW SITE 23	23	SOUTH END	42	032
SEL SW SITE 24	24	SOUTH END	43	033
SEL SW SITE 25	25	HEADQUARTERS	44	034
SEL SW SITE 26	26	FLA 1	45	035
SEL SW SITE 27	27	NORTH TOWER	46	036
SEL SW SITE 28	28	SOUTH TOWER	47	037
SEL SW SITE 29	29	SOUTH END	48	038
SEL SW SITE 30	30	SOUTH END	49	039
SEL SW SITE 31	31	HEADQUARTERS	50	040
SEL SW SITE 32	32	FLA 1	51	041
SEL SW SITE 33	33	NORTH TOWER	52	042
SEL SW SITE 34	34	SOUTH TOWER	53	043
SEL SW SITE 35	35	SOUTH END	54	044
SEL SW SITE 36	36	SOUTH END	55	045
SEL SW SITE 37	37	HEADQUARTERS	56	046
SEL SW SITE 38	38	FLA 1	57	047
SEL SW SITE 39	39	NORTH TOWER	58	048
SEL SW SITE 40	40	SOUTH TOWER	59	049
SEL SW SITE 41	41	SOUTH END	60	050
SEL SW SITE 42	42	SOUTH END	61	051
SEL SW SITE 43	43	HEADQUARTERS	62	052
SEL SW SITE 44	44	FLA 1	63	053
SEL SW SITE 45	45	NORTH TOWER	64	054
SEL SW SITE 46	46	SOUTH TOWER	65	055
SEL SW SITE 47	47	SOUTH END	66	056
SEL SW SITE 48	48	SOUTH END	67	057
SEL SW SITE 49	49	HEADQUARTERS	68	058
SEL SW SITE 50	50	FLA 1	69	059
SEL SW SITE 51	51	NORTH TOWER	70	060
SEL SW SITE 52	52	SOUTH TOWER	71	061
SEL SW SITE 53	53	SOUTH END	72	062
SEL SW SITE 54	54	SOUTH END	73	063
SEL SW SITE 55	55	HEADQUARTERS	74	064
SEL SW SITE 56	56	FLA 1	75	065
SEL SW SITE 57	57	NORTH TOWER	76	066
SEL SW SITE 58	58	SOUTH TOWER	77	067
SEL SW SITE 59	59	SOUTH END	78	068
SEL SW SITE 60	60	SOUTH END	79	069
SEL SW SITE 61	61	HEADQUARTERS	80	070
SEL SW SITE 62	62	FLA 1	81	071
SEL SW SITE 63	63	NORTH TOWER	82	072
SEL SW SITE 64	64	SOUTH TOWER	83	073
SEL SW SITE 65	65	SOUTH END	84	074
SEL SW SITE 66	66	SOUTH END	85	075
SEL SW SITE 67	67	HEADQUARTERS	86	076
SEL SW SITE 68	68	FLA 1	87	077
SEL SW SITE 69	69	NORTH TOWER	88	078
SEL SW SITE 70	70	SOUTH TOWER	89	079
SEL SW SITE 71	71	SOUTH END	90	080
SEL SW SITE 72	72	SOUTH END	91	081
SEL SW SITE 73	73	HEADQUARTERS	92	082
SEL SW SITE 74	74	FLA 1	93	083
SEL SW SITE 75	75	NORTH TOWER	94	084
SEL SW SITE 76	76	SOUTH TOWER	95	085
SEL SW SITE 77	77	SOUTH END	96	086
SEL SW SITE 78	78	SOUTH END	97	087
SEL SW SITE 79	79	HEADQUARTERS	98	088
SEL SW SITE 80	80	FLA 1	99	089
SEL SW SITE 81	81	NORTH TOWER	100	090
SEL SW SITE 82	82	SOUTH TOWER	101	091
SEL SW SITE 83	83	SOUTH END	102	092
SEL SW SITE 84	84	SOUTH END	103	093
SEL SW SITE 85	85	HEADQUARTERS	104	094
SEL SW SITE 86	86	FLA 1	105	095
SEL SW SITE 87	87	NORTH TOWER	106	096
SEL SW SITE 88	88	SOUTH TOWER	107	097
SEL SW SITE 89	89	SOUTH END	108	098
SEL SW SITE 90	90	SOUTH END	109	099
SEL SW SITE 91	91	HEADQUARTERS	110	100
SEL SW SITE 92	92	FLA 1	111	101
SEL SW SITE 93	93	NORTH TOWER	112	102
SEL SW SITE 94	94	SOUTH TOWER	113	103
SEL SW SITE 95	95	SOUTH END	114	104
SEL SW SITE 96	96	SOUTH END	115	105
SEL SW SITE 97	97	HEADQUARTERS	116	106
SEL SW SITE 98	98	FLA 1	117	107
SEL SW SITE 99	99	NORTH TOWER	118	108
SEL SW SITE 100	100	SOUTH TOWER	119	109
SEL SW SITE 101	101	SOUTH END	120	110
SEL SW SITE 102	102	SOUTH END	121	111
SEL SW SITE 103	103	HEADQUARTERS	122	112
SEL SW SITE 104	104	FLA 1	123	113
SEL SW SITE 105	105	NORTH TOWER	124	114
SEL SW SITE 106	106	SOUTH TOWER	125	115
SEL SW SITE 107	107	SOUTH END	126	116
SEL SW SITE 108	108	SOUTH END	127	117
SEL SW SITE 109	109	HEADQUARTERS	128	118
SEL SW SITE 110	110	FLA 1	129	119
SEL SW SITE 111	111	NORTH TOWER	130	120
SEL SW SITE 112	112	SOUTH TOWER	131	121
SEL SW SITE 113	113	SOUTH END	132	122
SEL SW SITE 114	114	SOUTH END	133	123
SEL SW SITE 115	115	HEADQUARTERS	134	124
SEL SW SITE 116	116	FLA 1	135	125
SEL SW SITE 117	117	NORTH TOWER	136	126
SEL SW SITE 118	118	SOUTH TOWER	137	127
SEL SW SITE 119	119	SOUTH END	138	128
SEL SW SITE 120	120	SOUTH END	139	129
SEL SW SITE 121	121	HEADQUARTERS	140	130
SEL SW SITE 122	122	FLA 1	141	131
SEL SW SITE 123	123	NORTH TOWER	142	132
SEL SW SITE 124	124	SOUTH TOWER	143	133
SEL SW SITE 125	125	SOUTH END	144	134
SEL SW SITE 126	126	SOUTH END	145	135
SEL SW SITE 127	127	HEADQUARTERS	146	136
SEL SW SITE 128	128	FLA 1	147	137
SEL SW SITE 129	129	NORTH TOWER	148	138
SEL SW SITE 130	130	SOUTH TOWER	149	139
SEL SW SITE 131	131	SOUTH END	150	140
SEL SW SITE 132	132	SOUTH END	151	141
SEL SW SITE 133	133	HEADQUARTERS	152	142
SEL SW SITE 134	134	FLA 1	153	143
SEL SW SITE 135	135	NORTH TOWER	154	144
SEL SW SITE 136	136	SOUTH TOWER	155	145
SEL SW SITE 137	137	SOUTH END	156	146
SEL SW SITE 138	138	SOUTH END	157	147
SEL SW SITE 139	139	HEADQUARTERS	158	148
SEL SW SITE 140	140	FLA 1	159	149
SEL SW SITE 141	141	NORTH TOWER	160	150
SEL SW SITE 142	142	SOUTH TOWER	161	151
SEL SW SITE 143	143	SOUTH END	162	152
SEL SW SITE 144	144	SOUTH END	163	153
SEL SW SITE 145	145	HEADQUARTERS	164	154
SEL SW SITE 146	146	FLA 1	165	155
SEL SW SITE 147	147	NORTH TOWER	166	156
SEL SW SITE 148	148	SOUTH TOWER	167	157
SEL SW SITE 149	149	SOUTH END	168	158
SEL SW SITE 150	150	SOUTH END	169	159
SEL SW SITE 151	151	HEADQUARTERS	170	160
SEL SW SITE 152	152	FLA 1	171	161
SEL SW SITE 153	153	NORTH TOWER	172	162
SEL SW SITE 154	154	SOUTH TOWER	173	163
SEL SW SITE 155	155	SOUTH END	174	164
SEL SW SITE 156	156	SOUTH END	175	165
SEL SW SITE 157	157	HEADQUARTERS	176	166
SEL SW SITE 158	158	FLA 1	177	167
SEL SW SITE 159	159	NORTH TOWER	178	168
SEL SW SITE 160	160	SOUTH TOWER	179	169
SEL SW SITE 161	161	SOUTH END	180	170
SEL SW SITE 162	162	SOUTH END	181	171
SEL SW SITE 163	163	HEADQUARTERS	182	172
SEL SW SITE 164	164	FLA 1	183	173
SEL SW SITE 165	165	NORTH TOWER	184	174
SEL SW SITE 166	166	SOUTH TOWER	185	175
SEL SW SITE 167	167	SOUTH END	186	176
SEL SW SITE 168	168	SOUTH END	187	177
SEL SW SITE 169	169	HEADQUARTERS	188	178
SEL SW SITE 170	170	FLA 1	189	179
SEL SW SITE 171	171	NORTH TOWER	190	180
SEL SW SITE 172	172	SOUTH TOWER	191	181
SEL SW SITE 173	173	SOUTH END	192	182
SEL SW SITE 174	174	SOUTH END	193	183
SEL SW SITE 175	175	HEADQUARTERS	194	184
SEL SW SITE 176	176	FLA 1	195	185
SEL SW SITE 177	177	NORTH TOWER	196	186
SEL SW SITE 178	178	SOUTH TOWER	197	187
SEL SW SITE 179	179	SOUTH END	198	188
SEL SW SITE 180	180	SOUTH END	199	189
SEL SW SITE 181	181	HEADQUARTERS	200	190
SEL SW SITE 182	182	FLA 1	201	191
SEL SW SITE 183	183	NORTH TOWER	202	192
SEL SW SITE 184	184	SOUTH TOWER	203	193
SEL SW SITE 185	185	SOUTH END	204	194
SEL SW SITE 186	186	SOUTH END	205	195
SEL SW SITE 187	187	HEADQUARTERS	206	196
SEL SW SITE 188	188	FLA 1	207	197
SEL SW SITE 189	189	NORTH TOWER	208	198
SEL SW SITE 190	190	SOUTH TOWER	209	199
SEL SW SITE 191	191	SOUTH END	210	200
SEL SW SITE 192	192	SOUTH END	211	201
SEL SW SITE 193	193	HEADQUARTERS	212	202
SEL SW SITE 194	194	FLA 1	213	203
SEL SW SITE 195	195	NORTH TOWER	214	204
SEL SW SITE 196	196	SOUTH TOWER	215	205
SEL SW SITE 197	197	SOUTH END	216	206
SEL SW SITE 198	198	SOUTH END	217	207
SEL SW SITE 199	199	HEADQUARTERS	218	208
SEL SW SITE 200	200	FLA 1	219	209
SEL SW SITE 201	201	NORTH TOWER	220	210
SEL SW SITE 202	202	SOUTH TOWER	221	211
SEL SW SITE 203	203	SOUTH END	222	212
SEL SW SITE 204	204	SOUTH END	223	213
SEL SW SITE 205	205	HEADQUARTERS	224	214
SEL SW SITE 206	206	FLA 1	225	215
SEL SW SITE 207	207	NORTH TOWER	226	216
SEL SW SITE 208	208	SOUTH TOWER	227	217
SEL SW SITE 209	209	SOUTH END	228	218
SEL SW SITE 210	210	SOUTH END	229	219
SEL SW SITE 211	211	HEADQUARTERS	230	220
SEL SW SITE 212	212	FLA 1	231	221
SEL SW SITE 213	213	NORTH TOWER	232	222
SEL SW SITE 214	214	SOUTH TOWER	233	223
SEL SW SITE 215	215	SOUTH END	234	224
SEL SW SITE 216	216	SOUTH END	235	225
SEL SW SITE 217	217	HEADQUARTERS	236	226
SEL SW SITE 218	218	FLA 1	237	227
SEL SW SITE 219	219	NORTH TOWER	238	228
SEL SW SITE 220	220	SOUTH TOWER	239	229
SEL SW SITE 221	221	SOUTH END	240	230
SEL SW SITE 222	222	SOUTH END	241	231
SEL SW SITE 223	223	HEADQUARTERS	242	232
SEL SW SITE 224	224			

TDM-180 CUSTOMER INFORMATION
RTL NO PAIR ASSIGNMENTS

END USER: TYP OF SAMPLE BRANCH SYSTEM ID: ABC-1234
 AGENCY: POLICE DEPT

PANEL: 1
 CONNECTOR: P14
 FUNCTION: LOGGING RECORDER
 TYPE: AMP 285 SLURR PROTECT: N

PAIR	COLOR	TRAY	SLOT	CONNECTIONS	FUNCTION
1	WHITE/BLU	2	1	R/R02	POLICE LOG
2	WHITE/GRN	2	2	R/R02	PREL. LOG
3	WHITE/GRN	2	3	R/R02	INTELLIGENCE LOG
4	WHITE/GRN	2	4	R/R02	DISPATCH LOG
5	WHITE/BLA	2	5	R/R02	SPIN LOG
6	RED/BLU				
7	RED/GRN				
8	RED/GRN				
9	RED/GRN				
10	RED/BLA				
11	BLU/BLU				
12	BLU/GRN				
13	BLU/GRN				
14	BLU/GRN				
15	BLU/BLA				
16					
17					
18	YEL/GRN				
19	YEL/BLA				
20	YEL/BLA				
21	YEL/BLU				
22	YEL/GRN				
23	YEL/GRN				
24	YEL/GRN				
25	YEL/BLA				

Figure 2-10 LOGGING RECORDER

TDM-180 CUSTOMER INFORMATION
AUXILIARY CONTROL RELAY ASSIGNMENTS

END USER: TYP OF SAMPLE BRANCH SYSTEM ID: ABC-1234
 AGENCY: POLICE DEPT

PANEL NUMBER: 1
 PANEL FUNCTION: AUXILIARY CONTROLS
 GPP CARD: ALK 8-12

RELAY NO	FUNCTION	ACTION	L LED CONTROL	R LED CONTROL
RY 1	DOOR OPEN DOOR	INTERMEDIATE	INT	14
RY 2	LIBRARY DOOR	SOFT	INT	20
RY 3	MEL ANSA DOOR	SOFT	INT	26
RY 4	POLICE INTX DOOR	SOFT	INT	40
RY 5	RAID PUMP	ALTERNATE	INT	INT
RY 6	CELL LIGHTS	ALTERNATE	INT	INT
RY 7	CELL CAMERA	ALTERNATE	INT	INT
RY 8	SPEAKERS	ALTERNATE	INT	INT

RELAY NO	FUNCTION	ACTION	L LED CONTROL	R LED CONTROL
RY 9				
RY 10				
RY 11				
RY 12				
RY 13				
RY 14				
RY 15				
RY 16				

NOTE: INT CONTROL OF LEFT OR RIGHT LED INDICATES LED IS UNDER SOFTWARE CONTROL, NOT EXTERNAL INPUT CONTROL.

Figure 2-11 AUXILIARY CONTROL RELAY ASSIGNMENTS

2.9 WIRING OF SURGE ARRESTOR BOXES

Typically, connectors P9 through P13 on the standard I/O panel (connectors P4 through P6 on 14 card cabinets) will be assigned for RTL I/O connectors.

1. Connect the female end of an A600950A, 25 pair cable to the connector in the surge box. Dress the cable as shown in Fig. 2-10. above. Use a split rubber grommet (furnished) to protect the cable where it passes through the surge box bottom flange. Connect the male end of this cable to the appropriate mating connector in the CPP cabinet. Use a CHAMP LOC spring (furnished) to secure each end of the connector. Coil and tie any excess cable - do not shorten the cable length.
2. Use 25 pair inside telephone cable to connect the surge arrestor block to an RTL demarcation point punch block following the standard color code assignment shown in Table 2-3. Since not all

installations use all pairs present on the surge arrestor block, some installers prefer to use individual 24 gauge solid twisted pair cross-connect wires rather than a 25 pair cable. Dress the cable or wire pairs using standard telephone wire management devices and techniques to effect a neat installation. The use of bridging clips on each demarcation block is strongly recommended to allow the console system to be isolated for troubleshooting. The connections are defined in reports titled RTL I/O PAIR ASSIGNMENTS. A separate report is provided for each I/O connector.

3. Be sure to replace the lids on all surge arrestor boxes. It is suggested that you place a copy of the pair assignments for each box inside the box for future reference.

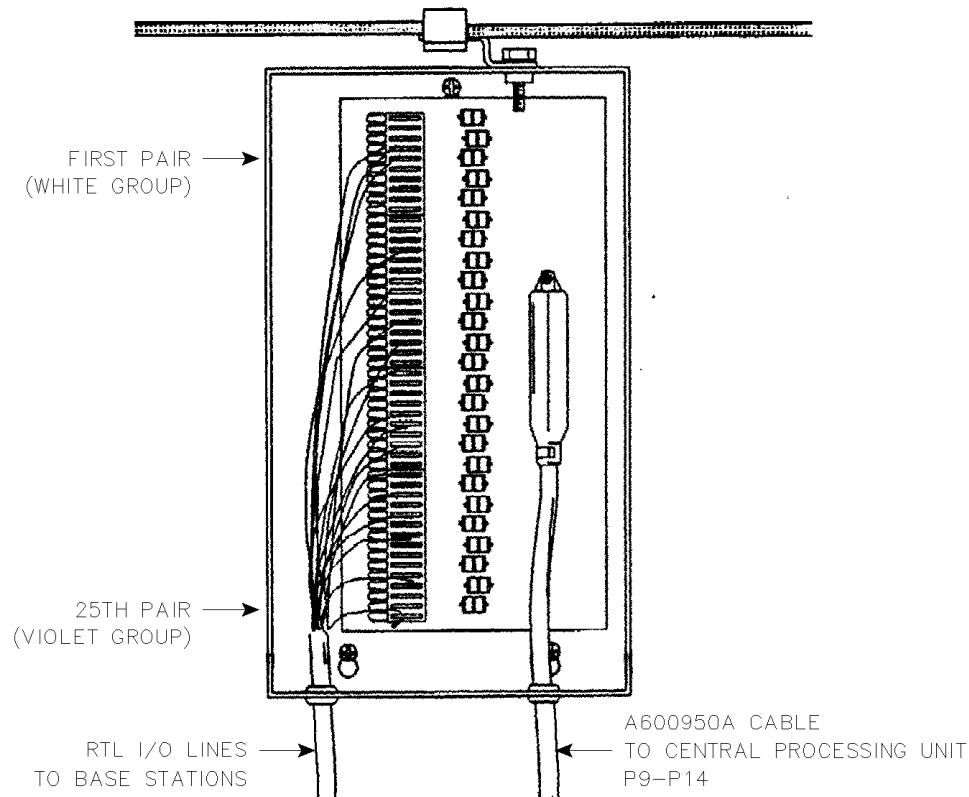

Figure 2-12 SURGE ARRESTOR BOX WIRING

Table 2-3 STANDARD COLOR CODE ASSIGNMENTS

CABLE	LINE	COLOR
Pair 1	1 2	White/Blue Blue/White
Pair 2	3 4	White/Orange Orange/White
Pair 3	5 6	Green/White White/Green
Pair 4	7 8	White/Brown Brown/White
Pair 5	9 10	White/Slate Slate/White
Pair 6	11 12	Red/Blue Blue/Red
Pair 7	13 14	Red/Orange Orange/Red
Pair 8	15 16	Red/Green Green/Red
Pair 9	17 18	Red/Brown Brown/Red
Pair 10	19 20	Red/Slate Slate/Red
Pair 11	21 22	Black/Blue Blue/Black
Pair 12	23 24	Black/Orange Orange/Black
Pair 13	25 26	Black/Green Green/Black
Pair 14	27 28	Black/Brown Brown/Black
Pair 15	29 30	Black/Slate Slate/Black
Pair 16	31 32	Yellow/Blue Blue/Yellow
Pair 17	33 34	Yellow/Orange Orange/Yellow
Pair 18	35 36	Yellow/Green Green/Yellow
Pair 19	37 38	Yellow/Brown Brown/Yellow
Pair 20	39 40	Yellow/Slate Slate/Yellow
Pair 21	41 42	Violet/Blue Blue/Violet
Pair 22	43 44	Violet/Orange Orange/Violet
Pair 23	45 46	Violet/Green Green/Violet
Pair 24	47 48	Violet/Brown Brown/Violet
Pair 25	49 50	Violet/Slate Slate/Violet

2.10 DISPATCH POSITION CONNECTIONS

Each dispatch position will plug directly into the J1 connector on the PIC line terminator board as shown in Figure 2-15. Console positions having more than four speakers will have two or more PICs and line terminator boards assigned. A label on the top of the line terminator board, as shown in Figure 2-15, will identify the position with the Console ID. The jumpers on the line terminator board determine whether the selected audio is sent to the left or right speaker on the console. Refer to the VR-CM50 Console Service Manual to adjust them. Refer to Section 2.6 for grounding information.

2.11 VOTER SYSTEM CONNECTIONS

If this system is specified for use with a voter system, the CPP is equipped with a TDM-AUX/V card for each voter shelf to be connected. The connection to each voter is through a 25 pair, male ribbon connector and a local interface board to be installed at the voter shelf. The I/O CONNECTOR PANEL ASSIGNMENTS report will define the connector position for each voter. The VOTING COMPARATOR DISPLAY/CONTROL MODULE report, as shown in Figure 2-9, defines the site and control connections. This report is formatted for either General Electric or Motorola voters in accordance with the data furnished to E.F. Johnson at the time of order. These reports are interleaved with the RTL I/O PAIR ASSIGNMENTS sheets at the designated connector locations. Refer to the VR-CM50 Voter Modification Kit Installation Guide - P/N 700901 ECL A, for specific voter shelf connection details.

2.12 LOGGING RECORDER CONNECTIONS

Mixed Tx/Rx audio for each individual channel is provided for connection to a logging recorder. The logging recorder output is a 600W balanced line at a level of -10 dBm. On tone controlled channels, the transmit audio will be stripped of guard tone (2175 hz) and function tones. On DC controlled channels, the transmit audio is DC blocked.

In the case of multi-receiver base stations, the audio from all receivers is summed with the transmit audio by bridging the logging recorder outputs of the LIC and the QRC cards. Jumpers on the QRC card, associated with the base station, can be set to isolate individual receiver audio, if required.

Typically, logging recorder audio appears on connector P14 on the standard I/O panel (connector P7 on 14 card CPP cabinets). If the CPP is housed in more than one cabinet, a separate logging recorder output will be provided from each cabinet to minimize the need for intercabinet wiring. Logging recorder connections are defined in reports titled RTL I/O PAIR ASSIGNMENTS, as shown in Figure 2-10. A separate report is provided for each connector.

2.13 PRINTER INSTALLATION

The Logging Diagnostic Printer option, TDM-OP205 is strongly recommended. In the event of a system reset, either manually or automatically initiated, the printed record is the only way to determine what actually happened.

Assemble the printer stand in accordance with the instructions supplied. If your CPP is housed in a 60" cabinet, the printer may be placed on top of the CPP. If your CPP is housed in an 88" cabinet, a separate printer shelf will be required. Do not attempt to mount the printer in the CPP cabinet. Unpack the printer and remove all shipping material. Insert the paper, making sure the tractor feed is engaged and the friction feed is disengaged.

Two 120 VAC convenience outlets for the printer and modem transformer are located in the upper left side of the CPP vent housing. If your CPP is housed in a 26" cabinet, the printer can be placed on top of the CPP, but no outlet is provided.

Special note for 230 volt system users: The printer supplied with your system is configured for 120 VAC operation. The convenience outlets on the CPP are powered via an approved 230V/120V step-down transformer. The printer must be connected to this outlet.

Connect the printer to the port on the I/O panel designated in the I/O CONNECTOR PANEL ASSIGNMENTS report. Usually, this is P15 on 60" and 88" cabinets, P8 on 26" cabinets. The printer has been programmed and tested prior to shipment. Refer to the printer instruction manual should problems be encountered.

2.14 MODEM INSTALLATION

This system is equipped with a modem to allow remote diagnostics and programming via a dial-up phone line. The modem has been properly configured for 2400 baud operation and tested at the factory prior to shipment. Do not change the modem programming without specific authorization from E.F. JOHNSON Technical Support. If you wish to access the system via modem, your PC must be equipped with TDM-OP208/PC Maintenance Software. Contact E.F. Johnson Technical Support for details.

Connect the RS232 jack on the modem to the modem port on the I/O panel designated in the I/O CONNECTOR PANEL ASSIGNMENTS report. Usually, this is P17 on 60" and 88" cabinets, P10 on 26" cabinets.

Two 120 VAC convenience outlets for the modem transformer and printer are located in the upper left side of the CPP vent housing on 60" and 88" cabinets. If your CPP is housed in a 26" cabinet, no outlet is provided.

Special note for 230 volt system users: The modem transformer supplied with your system is designed for 120 VAC operation. The convenience outlets on the CPP are powered via an approved 230V/120V step-down transformer. The modem must be connected to one of these outlets.

Connect the RJ-11 modular LINE jack on the modem to the telephone line designated for modem communications. If additional instruments are to be routed through the modem for voice use, these should be connected to the RJ-11 PHONE jack on the modem.

2.15 CONNECTION TO AUXILIARY CONTROL FUNCTIONS (Standard Cabinet)

If the console was ordered with auxiliary switch functions specified, the CPP cabinet will have one or more auxiliary relay panels installed. A typical relay panel is shown in Figure 2-13. The standard relay panel, furnished with a TDM-AUX includes eight relays. An additional eight relays can be added by specifying option TDM-AUX/E8. Relays 1 through 8 are located at the bottom of the panel. Expansion

relays 9 through 16 mount at the top of the panel. The Customer Data Sheets which are included in the VR-CM50 Console Service Manual, Volume 1, will define the relay panel assignments for all Auxiliary I/O functions. Individual relay and input assignments are defined in a report titled AUXILIARY CONTROL RELAY ASSIGNMENTS located behind the RTL I/O PAIR ASSIGNMENTS sheets.

Each auxiliary function key has two logic inputs and one output relay assigned to it. Input functions vary widely from system to system but typically, the inputs control key indications. In most cases, A inputs control the left or off indication and B inputs control the right or "on" indication. Inputs must be a logic ground which can sink approximately 20 ma. Use extreme caution in wiring the auxiliary func-

tions. The application of AC line voltage to an A or B input terminal will cause serious damage to the processor circuitry.

Each auxiliary output is a 4PDT relay having a contact rating of 5 amperes at 120 VAC. If higher voltages or currents must be controlled, use the relay in the CPP as a pilot relay to operate an external contactor. Each relay is mounted in a DIN socket with screw terminals that can accept up to #12 wire. Refer to Figure 2-13, for a detail of the relay connections.

IMPORTANT

The relay panel in the CPP is hinged to allow access to the backplane circuitry behind it. In wiring to the auxiliary inputs and relays, dress all wiring from the hinge side of the panel.

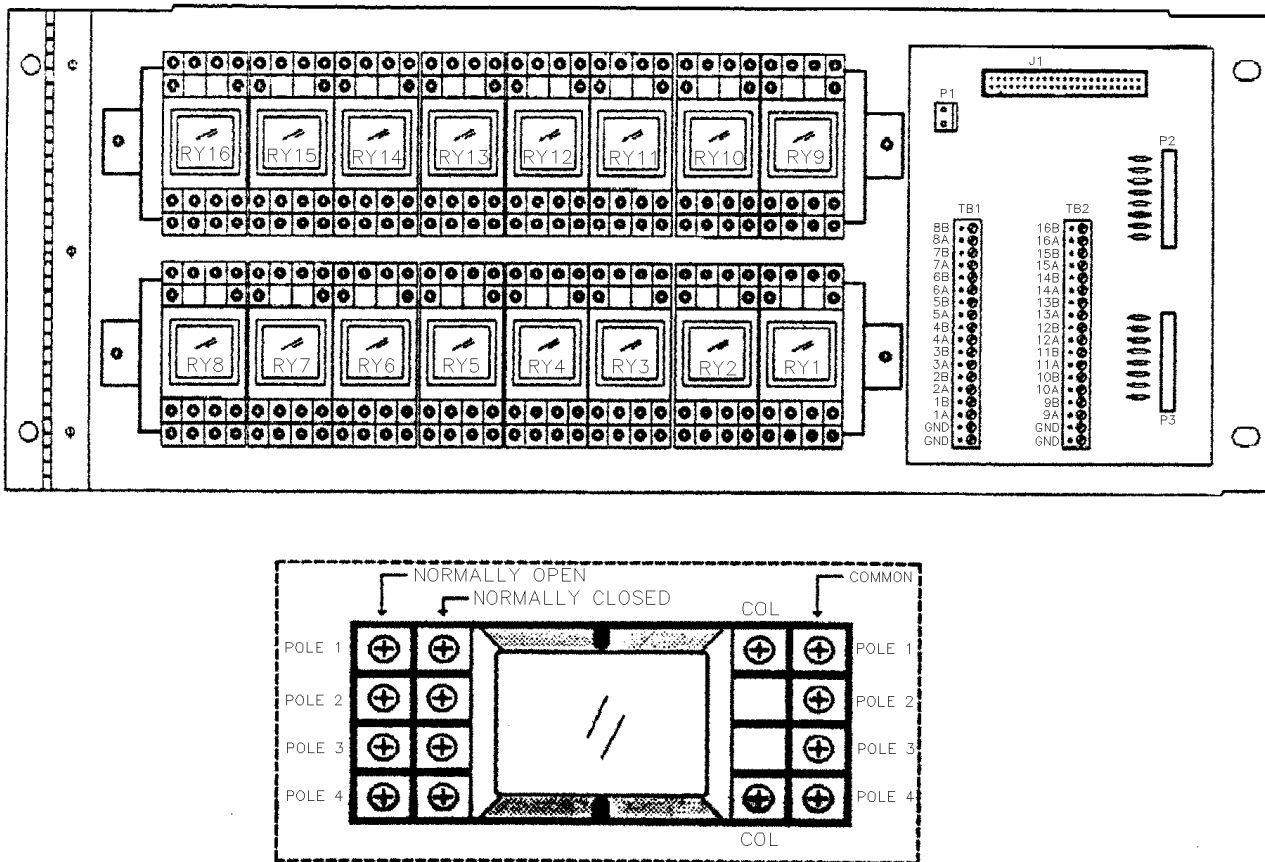

Figure 2-13 CPU RELAY PANEL

2.16 CONNECTION TO AUXILIARY CONTROL FUNCTIONS (14 Card Central Cabinet)

The 14 card Central Processor can accommodate only one Auxiliary Control Relay card with a maximum of 16 relays. A somewhat different relay mounting arrangement is used due to space limitations. Relays 1 through 8 are mounted vertically with RY1 at the bottom of the mounting strip. Note carefully the location of the COIL terminals; the relay sockets are rotated 900 clockwise from the

CPU main Relay Panel as shown in Figure 2-14. The TDM-AUX/E8 accessory provides relays 9 through 16, just as in the larger cabinets. In this package however, the accessory relay strip is stacked above the primary relay strip as shown in Figure 2-14 with addition of AUX/E8.

The A and B control inputs are contained on a circuit board which mounts on the sidewall of the relay housing to the left of the primary relay strip. All control functions are identical to those shown for larger CPP cabinets.

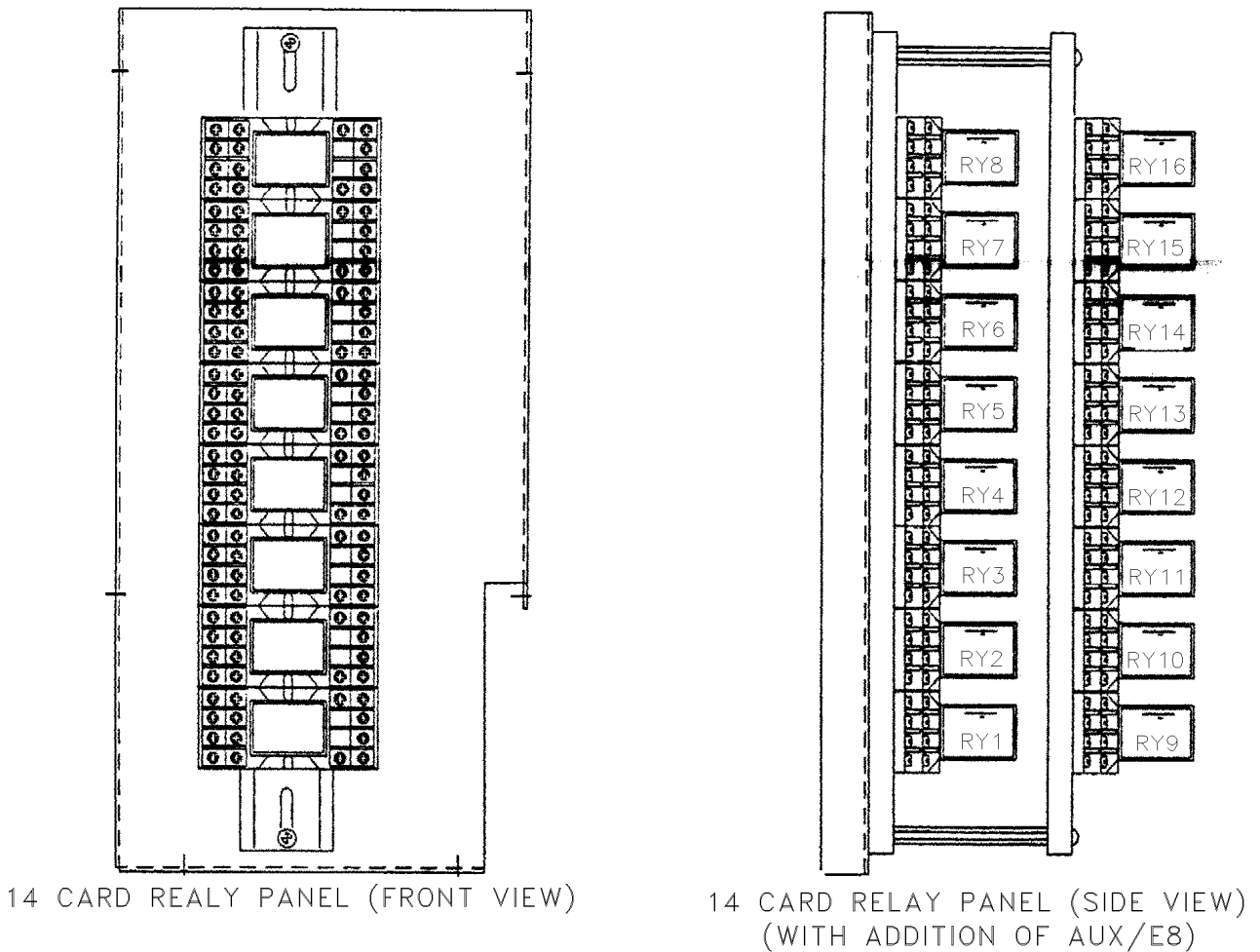

Figure 2-14 14 CARD RELAY PANEL

2.17 PA SYSTEM FEED

The CPP can be connected to a building public address to permit paging via the dispatch console(s). The console(s) must be equipped with programming option TDM-OP431 or TDV-OP431 to use this feature.

1. Connection to the PA system is made from TB4 on the CSC line terminator I/O board, located on the rear of the CPP power supply as shown in (see Figure 2-15 for terminal locations on the Line Terminator Board).
2. PA feed audio is obtained from terminals A1 and A2. The audio output is a 600W balanced line at -10 dBm.

3. PA PTT is obtained from terminals K1 and K2. PTT is an isolated, normally open dry contact closure, which may be wired into the audio path or used to control an amplifier gate (preferable).

2.18 CONNECTIONS TO AC POWER

The CPP is connected to its AC power feed via a surge protected power distribution strip in the CPP cabinet. One strip will be provided for every two, 60" cabinets or each individual 88" cabinet. An IEC-320 input connector and line cord is located on the bottom of the AC strip. The line cord connector has been supplied in accordance with the power supply option specified at the time of order.

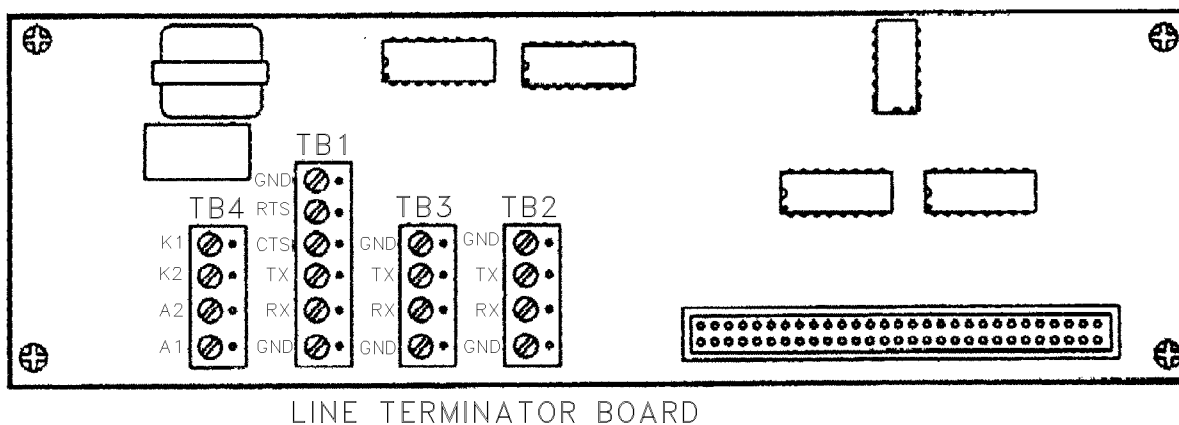
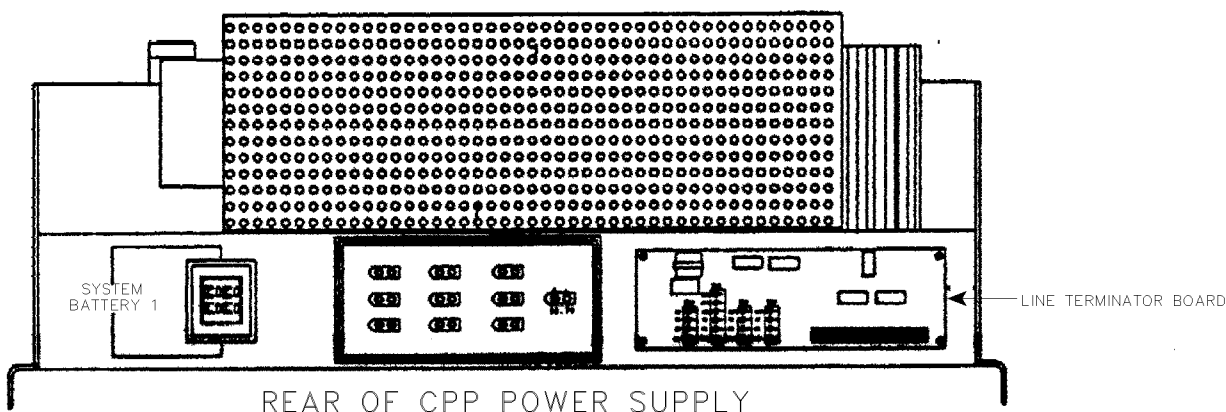

Figure 2-15 CPP POWER SUPPLY

SECTION 3 CABINETRY ASSEMBLY FOR CRT CONSOLE SYSTEMS

3.1 INTRODUCTION

This section contains the instructions to assemble VR-CM50 CABINETRY. If you purchased a complete VR-CM50 system, most electronic components will be pre-installed in your VR-CM50 cabinetry.

3.2 TOOLS REQUIRED

The following tools are needed for mechanical assembly of the TDM-150 Console cabinetry.

- #2 Phillips Screwdriver
- Power Screwdriver with #2 Phillips Bit
- 3/8" Open End Wrench
- 7/16" Open End Wrench
- 1/2" Open End Wrench
- 3/8" Square Drive 7/16" Socket
- Carpenter's Level
- White Carpenter's Glue (Required only if multiple writing surfaces must be joined)

3.3 CONSOLE ARRANGEMENT

Consoles are shipped in 2, 3 or 4 bay sections depending on the final cabinet configuration. Before assembly begins, arrange the console sections (bays) in their proper room layout positions. Individual sections will be identified with letters A, B, and C, beginning with left-most section. The letter designations will appear on the inside ends of the console frame. Refer to your proposal diagram for the correct layout positions. A sample proposal diagram is shown in Figure 3-1.

It is important to note that the console sections should not be forced to conform to surrounding walls or structures. This will ultimately bend the console frames so that the Formica will not fit properly as designed.

Once the Formica writing surface is permanently mounted, **DO NOT ATTEMPT TO MOVE THE CONSOLES!**

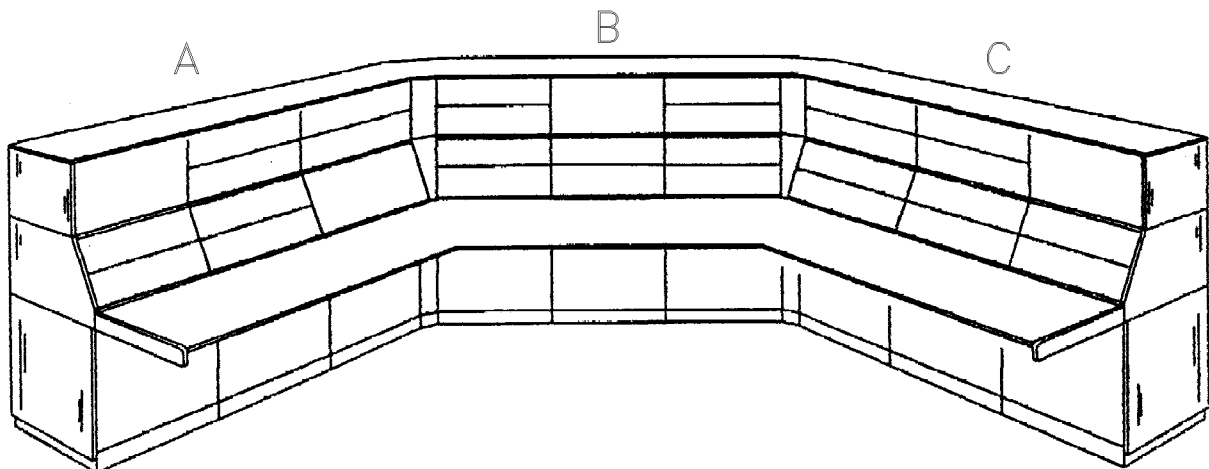

Figure 3-1 SAMPLE CONSOLE LAYOUT

3.4 MAIN CONSOLE ASSEMBLY

4. Remove the front and rear keylocked enclosure panels from each bay and set them aside.

CAUTION

Keylocks will scratch keylock enclosure panels if they are stacked or leaned against each other.

5. Accurately place the console section at its final location before continuing with STEP 3.
6. Using #1/4-20 x 3/4 hex bolts and #1/4-20 x 3/4 Keps nuts, attach the console sections together using pass-through holes in the sides.

Note: Be consistent when orienting the bolts in the pass-through holes. Refer to Figure 3-3.

Do not attach the consoles at the centermost holes. These holes will be used to fasten the writing support rails. Refer to Section 3.7.

7. Be sure the sections are in perfect alignment before securing the fasteners.

HINT: When aligning console sections, a #2 Phillips screwdriver may be placed through one of the centermost holes and used as an alignment tool.

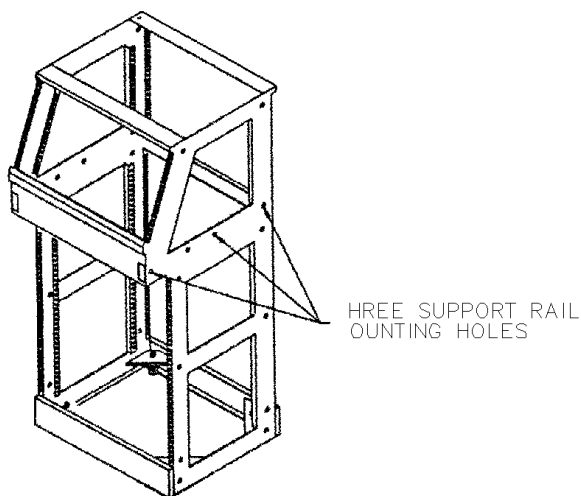

Figure 3-2 WRITING SUPPORT MOUNTING HOLES

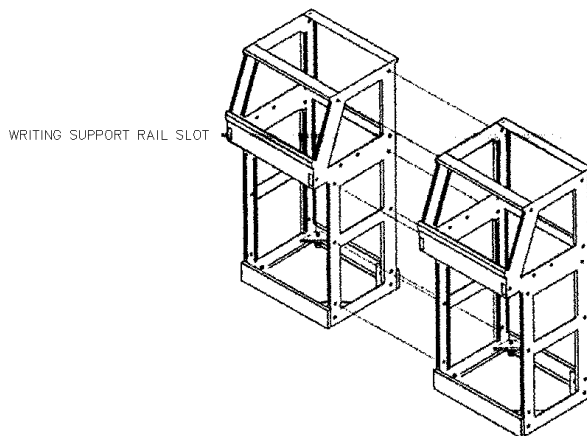

Figure 3-3 ASSEMBLY OF CONSOLE SECTIONS

3.5 CONSOLE LEVELING

1. Consider carefully where the consoles are located. Any gross unevenness in the flooring should be eliminated. Small deviations can be compensated using the individual levelers at each console.

Note: Levelers are screwed in all the way in shipment. Refer to Figure 3-5.

2. Level the console assembly both side-to-side and front-to-back using the threaded levelers in each cabinet section. Levelers can be adjusted by using an 1/2" open end wrench or by hand turning. *Hint: a piece of scrap wood may be used to prop up the console to aid in leveling. Be sure each leveler is snug against the floor and supports its proper share of the overall weight.*

NOTE: Once the levelers have been extended, do not shift the console position. Lateral movement can bend the leveler stems making proper adjustment extremely difficult.

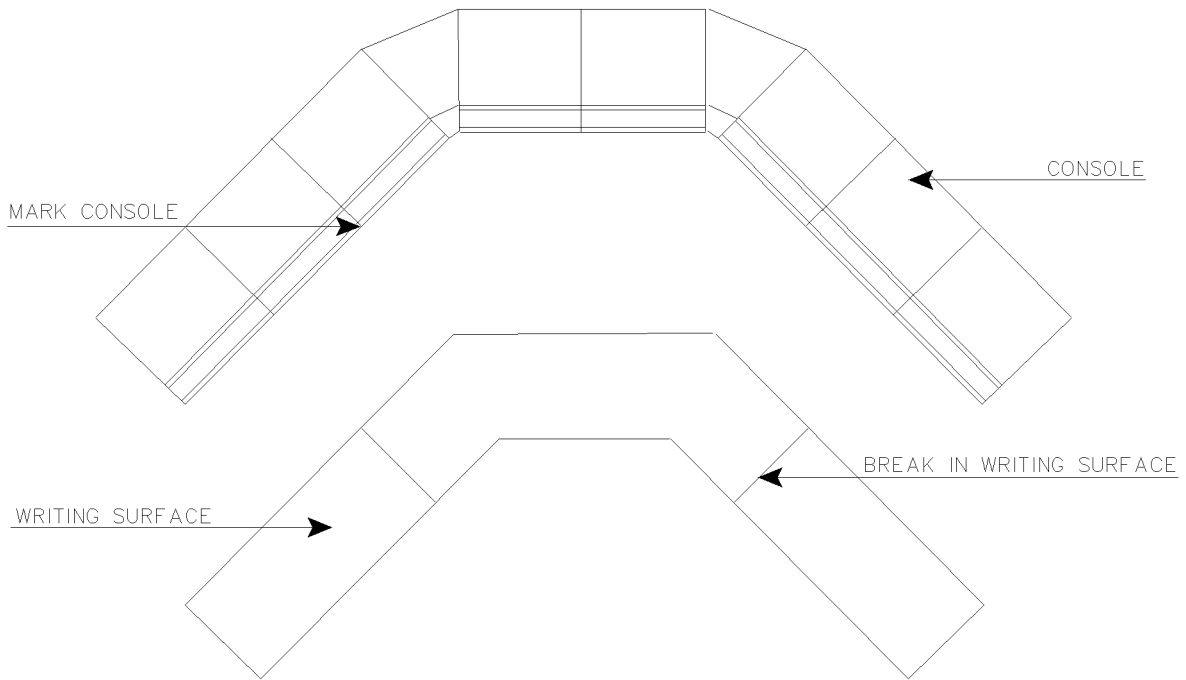

Figure 3-4 FORMICA SURFACE ARRANGEMENT

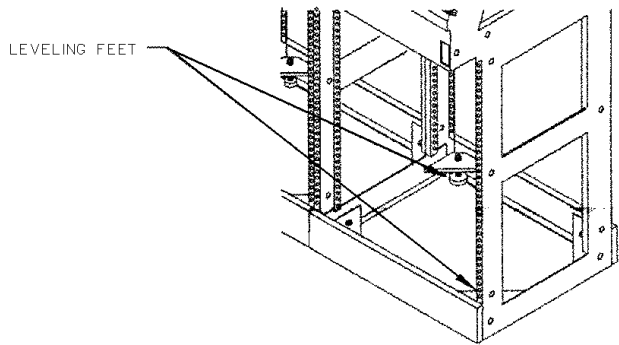

Figure 3-5 LEVELING THE CONSOLE

3.6 FORMICA WRITING SURFACE ARRANGEMENT

1. Locate all writing surface Formica and arrange on the floor in front of console. A typical layout is shown in Figure 3-4. Permanent mounting can be accomplished more easily if the Formica is arranged on the floor directly in line to its mounting position on the console.

2. Mark the console face where the breaks occur in the Formica writing surface. The marks should be made below the writing surface plane so that they will be hidden when the Formica is installed.

3.7 WRITING SUPPORT RAIL MOUNTING

The writing support rails are necessary for mounting and providing support to the Formica writing surfaces of consoles. One support rail is provided for each side-by-side cabinet bay consisting of two or more consoles including pie-shaped pieces. For two-bay cabinetry, one support rail is provided at each end and in the middle. For convenience, the rails and their mounting locations are numbered.

1. Install the writing support rail number at the corresponding location number found on the side of the console frame.

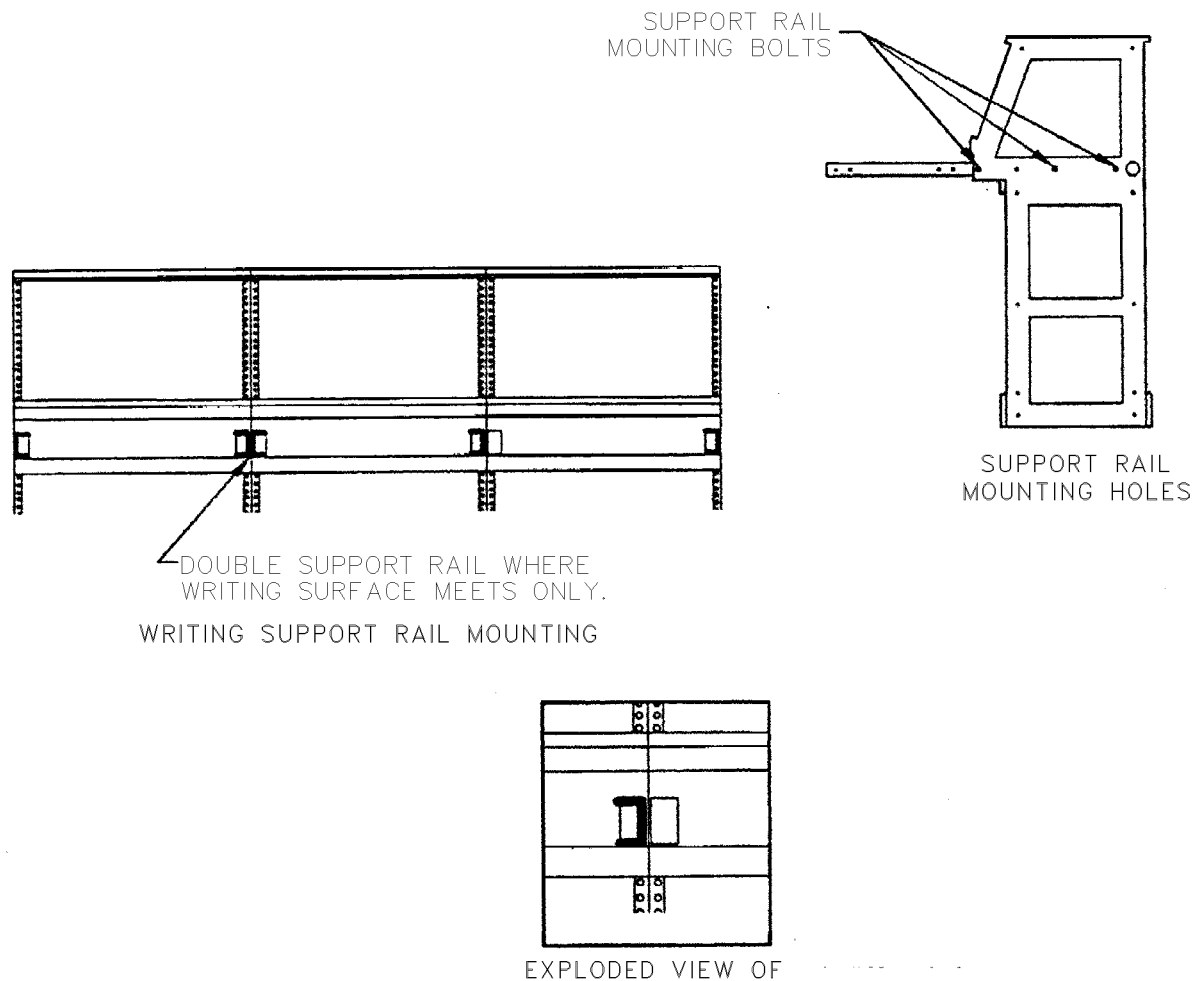

Figure 3-6 WRITING SUPPORT RAIL MOUNTING

2. Fasten the writing support rail with three #1/4-20x3/4 Keps nuts as shown in Figure 3-6. One support rail must be used on either side of writing surface break as previously marked.
3. All other bays use only one support rail per bay as shown in Figure 3-6.
4. It may become necessary to partially remove the equipment in the sloped turret to access holes for mounting the support rails. Removal of four panel mounting screws allows the tray to slide out and rest on hinges as shown in Figure 3-7.

NOTE: If the console has a keyboard recess, a shorter keyboard support rail is used in place of a writing support rail. Refer to Figure 3-11.

If the system configuration includes 45° sections:

1. Remove the front #1/4-20x3/4 hex bolt.
2. Slide the support rail through the slot and replace the bolt.

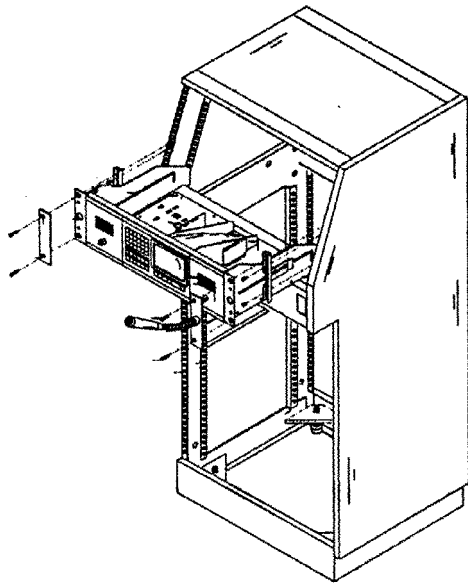

CTP TRAY EXTENDED

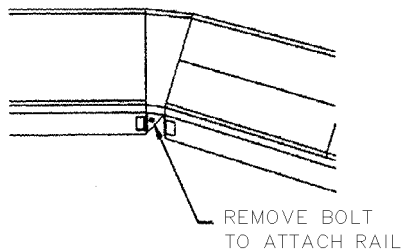

SUPPORT RAIL INSTALLATION ON 45° SECTION

Figure 3-7 CTP TRAY

3.8 ATTACHING THE FORMICA WRITING SURFACE

1. Position all writing surfaces on the writing support rails.
2. Where a split occurs in the Formica writing surface, insert wood biscuits into the slots on the sides of the surfaces. Refer to Figure 3-8.

HINT: To help align the Formica writing surfaces flush, it is advisable to glue the biscuits into place using white carpenter's glue.

3. Pass the driver through the access in the bottom of the support rail and drive #10x3/4" flakeboard screws* up into the Formica writing surface. Refer to Figure 3-9.
4. Align as necessary using an electric screwdriver with a #2 Phillips driver.

NOTE: Hex extensions or long hex drivers will not pass through the holes.

CAUTION

Use only VR-CM50-provided flakeboard screws to fasten the writing surface. Longer screws will protrude through the Formica surface.

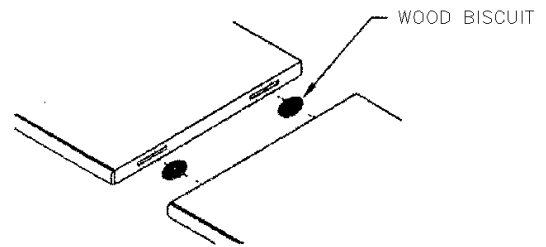

Figure 3-8 JOINING FORMICA

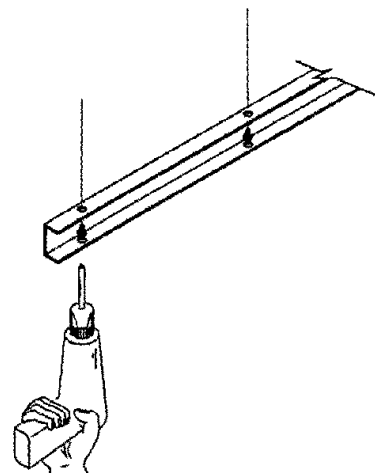
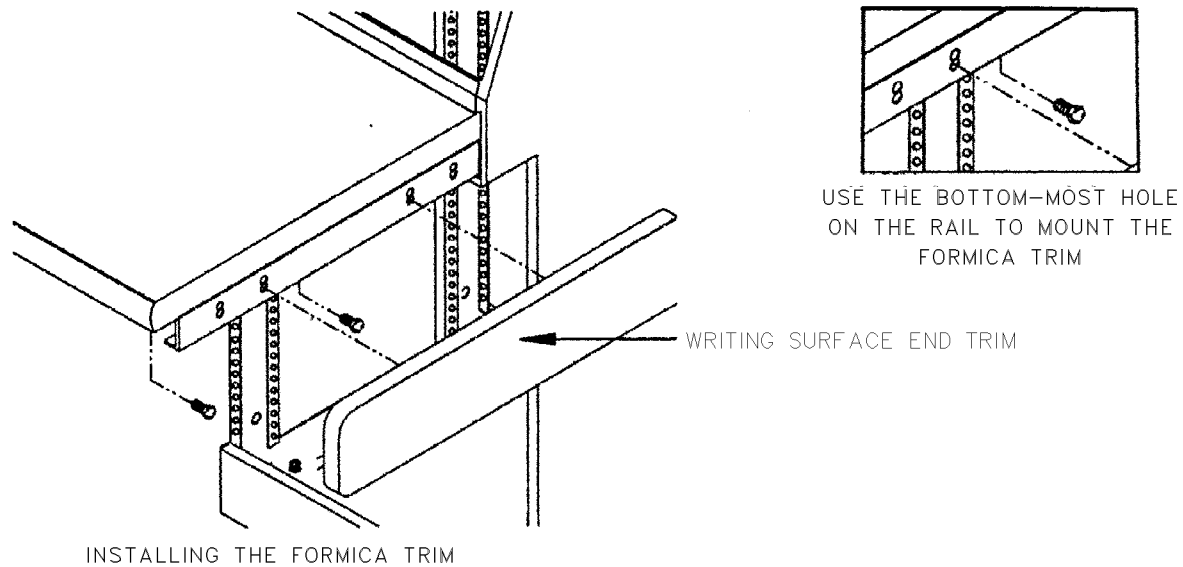
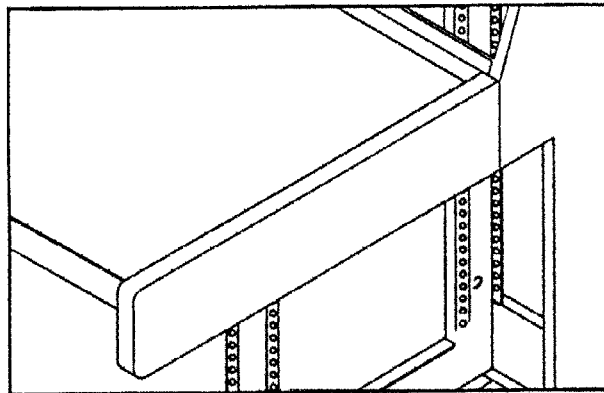

Figure 3-9 SECURING THE FORMICA WRITING SURFACE



INSTALLING THE FORMICA TRIM



CORRECTLY INSTALLED FORMICA WRITING SURFACE TRIM

Figure 3-10 FORMICA WRITING SURFACE AND TRIM

3.9 FORMICA WRITING SURFACE AND TRIM

1. Align the Formica writing surface end trim with the double holes in the last writing support rail. Use the bottom-most hole, on the rail, to mount the Formica writing surface end trim.
2. Fasten the Formica writing surface end trim using the two (2) fender 1/4x1" washers and two (2) 8-32x1/2 screws as shown in Figure 3-10.
3. A correctly mounted Formica writing surface end trim is shown in Fig. 3-15. Notice that the bottom of the end trim aligns perfectly with the console end kit metal.

Replace all keylocked enclosure panels. The standard mechanical assembly is now complete. If your console configuration has optional equipment, PLEASE CONTINUE.

3.10 CABINETY OPTIONS

VR-CM50 offers the following cabinetry options for your system. Installation instructions begin in the follow sections:

3.10.1 STABILIZER KIT (OPTION 1)

Refer to Figure 3-11. For cabinetry consisting of two or more in-line cabinet bays, two (2) stabilizer kits are required - one at each end of the console. For

cabinetry consisting of a pie-shape sections along with 2 or more cabinet bays in-line before the turn, one (1) stabilizer kit only is required at the end opposite the pie-shaped section. For assembly purposes, each console that is required to have a stabilizer installed, is identified with a label: Mount Stabilizer Leg Here

1. Align the stabilizer leg with the bottom holes of the console bay as indicated.
2. Fasten with two (2) # -20x hex bolts.
3. Conceal the bolts by placing hole plugs as shown in Figure 3-11.

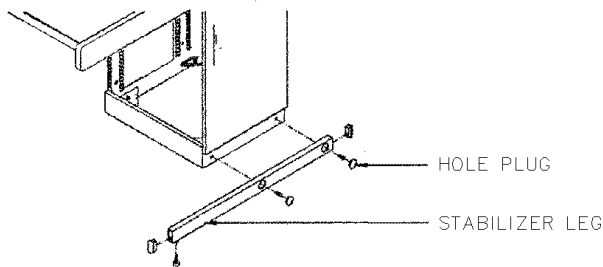

Figure 3-11 STABILIZER KIT

3.10.2 ADJUSTABLE KEYBOARD SEAT (OPTION 2)

Refer to Figure 3-12.

1. Mount the keyboard support rail (#2 short rail) in the rear of the keyboard opening.
2. Align the adjustable keyboard seat with the writing surface cutout.
3. Drive seven (7) #10 x 3/4 flakeboard screws up into the wood using the pre-drilled holes.

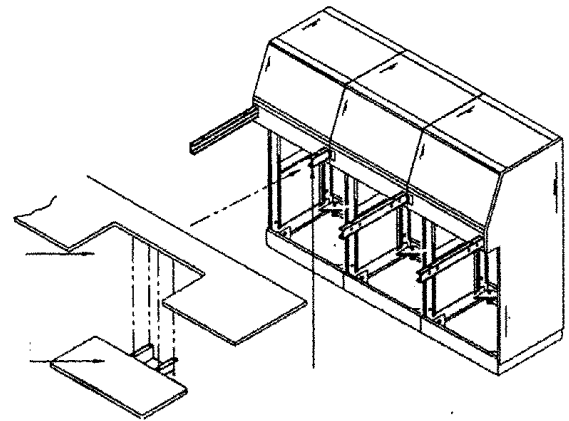

Figure 3-12 ADJUSTABLE KEYBOARD SEAT

3.10.3 UNIVERSAL KEYBOARD DRAWER MOUNTING (OPTION 3)

Refer to Figure 3-13.

1. Mount the #2 short keyboard support rails as in Option 2, behind the keyboard drawer.
2. Position the keyboard drawer 1" back from the front of the Formica writing surface.
3. Drive six (6) #10 x 3/4 flakeboard screws up into the wood.

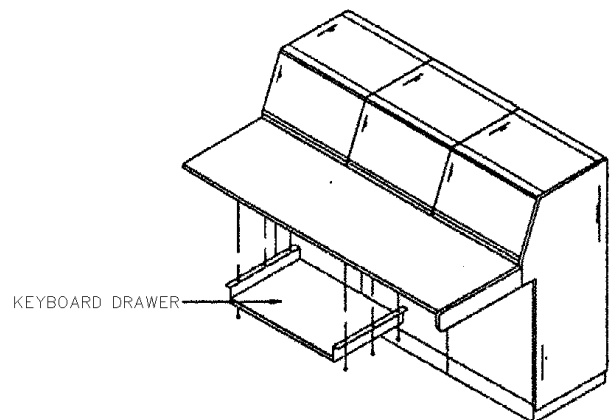

Figure 3-13 KEYBOARD DRAWER MOUNTING

3.10.4 UNIVERSAL PENCIL DRAWER MOUNTING (OPTION 4)

1. Remove the pencil drawer from the mounting frame by depressing the black slide retainers. Refer to Figure 3-14.
2. Position the mounting frame in the desired location between the writing support rails - 1" back from the front of the Formica writing surface.
3. Drive six (6) #10 x 3/4 flakeboard screws up into wood. Refer to Figure 3-14
4. Re-insert the pencil drawer.

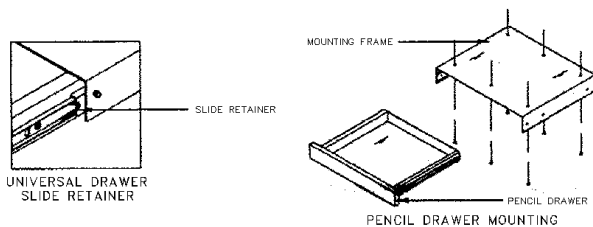

Figure 3-14 UNIVERSAL PENCIL DRAWER MOUNTING

3.10.5 TYPEWRITER EXTENSION ASSEMBLY (OPTION 5)

Refer to Figure 3-15. The Typewriter Extension Assembly consists of a typewriter extension, a typewriter extension support, two (2) triangle braces and hardware. It is packed flat for shipping and must be assembled in the field.

NOTE: The following assembly instructions pertain to both 18" and 21" typewriter extension lengths.

1. Attach the triangle brace to the modesty panel using three (3) 10-32x1/2 pan head screws for each triangle brace.
2. Flip the typewriter extension over on its top side to attach the other side of the triangle brace. Use three (3) 10x3/4 flakeboard screws for each triangle brace and attach to the typewriter extension.

3. Attach the typewriter extension support to the typewriter extension using four (4) 10x3/4 flakeboard screws. (On 21" typewriter extensions, five (5) 10x3/4 flakeboard screws are used).
4. Attach the entire assembly to the position desired on the Formica writing surface. Use four (4) 10x3/4 flakeboard screws to secure the assembly to the Formica writing surface. (On 21" typewriter extensions, five (5) 10x3/4 flakeboard screws are used).
5. Hand turn the leveling feet at the bottom of the modesty panel to ensure a level typewriter extension surface.

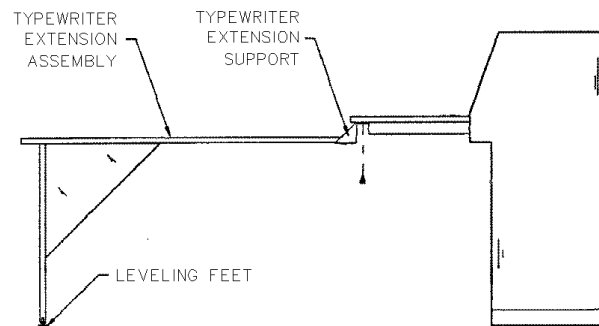

Figure 3-15 TYPEWRITER EXTENSION ASSEMBLY

3.10.6 PIE SUPPORT RAIL MOUNTING (OPTION 6)

Refer to Figure 3-16. The Pie Support Rail is attached using the same hole pattern as the writing support rail.

1. Mount the rail with the angle of the rail following the angle of the break in the writing surface.
2. When the Formica writing surface is attached, use two (2) flakeboard screws on each side of the writing surface break. Refer to the Section 3.5.

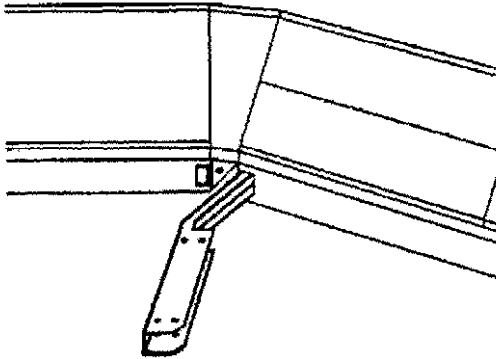

Figure 3-16 PIE SUPPORT RAIL MOUNTING

3.10.7 CRT MONITOR SHELF - FXM-192 (OPTION 7)

The hardware in Table 3-1 is included with the Monitor Shelf assembly (FXM-192):

1. Mount the Tinnerman Clips

- a. Snap the Tinnerman clips onto the left and right sides of the console frame at the second, third and seventh hole, counting up from the bottom cowl. Repeat the same, counting down from the top cowl.
- b. Attach the EIA Shims - Attach the EIA shims using two (2) 12-24x pan head Phillips screws per shim to the Tinnerman clips at holes 3 and 7, 12 and 16, counting down from the top cowl.
- c. Remove the Distribution Rail - Remove the distribution rail at the rear of the cabinet by removing the four (4) 1/4-20x3/4 hex bolts. Put them aside to use for reassembly.
- d. Install the Right and Left Inner Closures - Install the right-side inner closure by sliding it in from the front of the console and placing its shim between the already installed "EIA" shims and "inner closure" itself. (All holes line up when seated properly). Screw in the right-side closure with the four (4) 12-24x1" black truss head Phillips screws and #12 black nylon washers. Repeat this procedure for the left side.

2. Mount the CRT Monitor Shelf

The monitor shelf is mounted in the base section of the FC192 cabinet. Refer to Figure 3-18.

- a. Snap Tinnerman clips to the 6th hole counting down from the top of the lower frame side on both the front left and right sides of the cabinet.
- b. Snap Tinnerman clips to the 8th hole counting down from the top of the lower frame side on both the rear left and right sides of the cabinet.
- c. Install the monitor shelf with the four (4) 12-24x pan head Phillips screws provided. The monitor shelf mounts with the 2.5" hole to the rear.
- d. Remount the distribution rail to holes 31 and 33 (counting up from the console bottom) using the (4) -20x3/4 hex bolts previously removed.

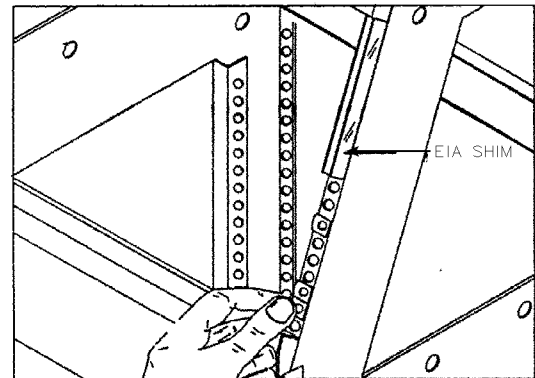

Figure 3-17 INSTALLING TINNERMAN CLIPS

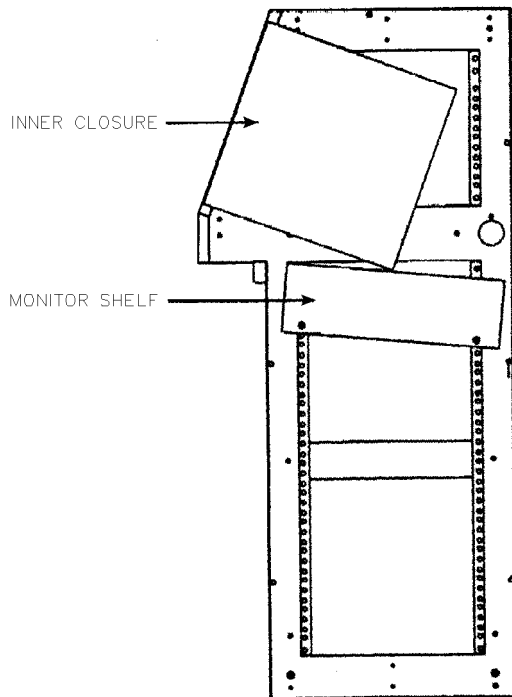

Figure 3-18 CRT MONITOR SHELF

Table 3-1 MONITOR SHELF HARDWARE

Qty.	Part No.	Description
16	280621122400	Tinnerman Clips
12	280114122408	12-24x1/2 Pan Head Philips Screw
4	280129122416	12-24x1 Truss Head Philips Screw
4	280359120010	#12 Black Nylon Washer
4	141140093B	"EIA" Shim
2	144153069	10.5 inch Long Shim
1	144153161I	Left Inner Closure
1	144153161R	Right Inner Closure
1	144153162	Monitor shelf

SECTION 4 CRT-BASED ELECTRONICS ASSEMBLY PART I

4.1 INTRODUCTION

Since you have purchased the E.F. JOHNSON console system as electronics only and intend to use another manufacturer's cabinetry, these install instructions will have to be interpreted broadly.

4.2 INSTALL THE PC/UPS SLIDE TRAY

Table 4-1 PC UPS OPTION NUMBERS

PC CPU Part No.	200TC4862501
Possible option numbers for the PC UPS	
Part Number	Country
TDV-OP400/A	North America
TDV-OP400/GB	Great Britain, S. Africa
TDV-OP400/E	Europe
TDV-OP400/I	India
TDV-OP400/NZ	New Zealand/Australia

Table 4-2 SLIDE TRAY HARDWARE

Qty	Part No.	Description
8	280621122400	Tinnerman Clips
8	280124102412	12-24x1/2 PH Phil Screw
2	Slide Assembly (see Figure 4-1)	
	Qty.	Part No. Description
	2	144233259 Mounting Bracket
	2	146563216 16" Slide Assembly
1	Slide Assembly (see Figure 4-1)	
	1	144233258 Tray
	1	124163270 Swivel Mount
	1	144233386 PC Tray Bracket

- Attach the slide mount assemblies to the bottom of the console using eight (8) Tinnerman clips (280621122400) and eight (8) 12-24x pan head Phillips screws (280124102412) to the left and right sides. If you have E.F. JOHNSON cabinetry, use the second hole and eighth hole from the bottom.

- Slide the Slide Tray Assembly onto the slide mounts. Refer to Figure 4-1.

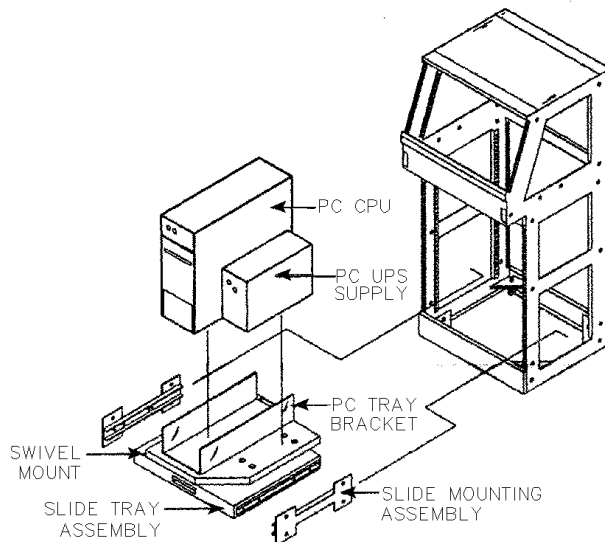

Figure 4-1 PC AND UPS SLIDE TRAY ASSEMBLY

4.3 CRT INTERFACE PROCESSOR (CIP)

Table 4-3 POWER SUPPLY HARDWARE

Qty	Part No.	Description
4	280621122400	Tinnerman Clips
4	280124102412	12-24x1/2 PH Phil Screw

4.3.1 INSTALL THE CIP POWER SUPPLY

- Install the CIP Power Supply in the upper turret of the console directly behind the CIP tray. Use the four (4) Tinnerman clips and four (4) 12-24x1/2 pan head Phillips screws to secure the power supply to the console frame.

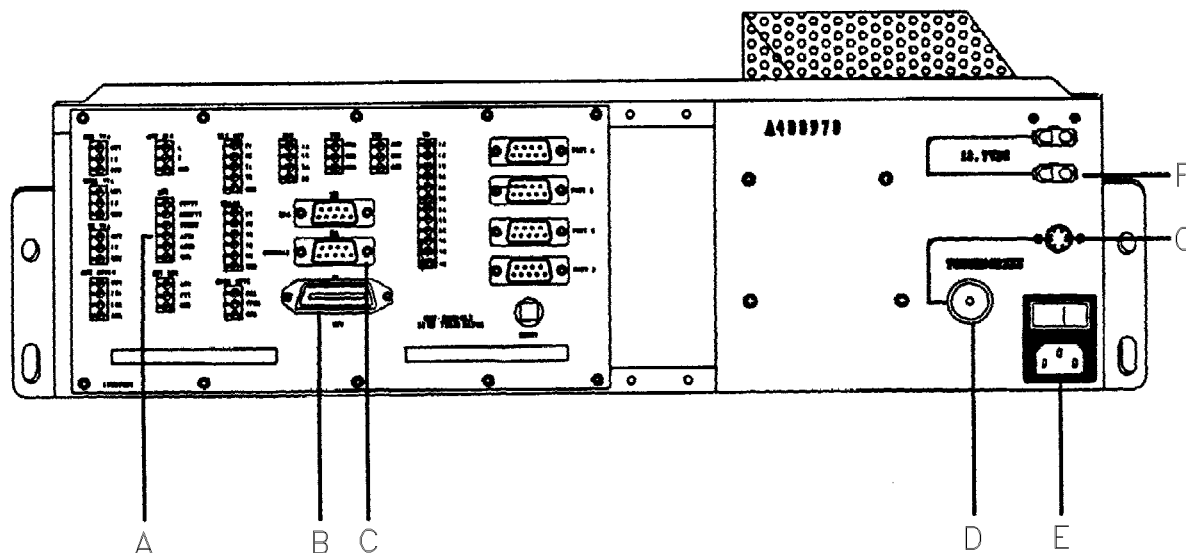

Figure 4-2 CIP POWER SUPPLY

NOTE: If the CIP power-supply and the CIP tray are being mounted over the monitor in a 5 or 10 turret, a shield plate has to be installed between the monitor and turret. Use a 16 ga cold rolled steel magnetic shield plate. The part number used in cabinetry is 144113434.

- A UPS Power Fail
- B CPP Data
- C PC COM3
- D Circuit Breaker
- E Power Connector
- F 13.7V DC Accessory Outlets
- G Touchscreen (DIN) Connector

4.3.2 INSTALL THE CRT INTERFACE PROCESSOR (CIP) TRAY

Table 4-4 CIP TRAY HARDWARE

Qty	Part No.	Description
8	280621122400	Tinnerman Clips
4	280114122408	12-24x1/2 PH Phil Screw
4	280129122416	12-24x1 Truss Head Phil
4	280359120010	#12 black nylon washer
1	141230970A	Black trim strip

Mount The CIP Tray

Install the CIP tray at the location indicated in the Customer Specifications Documentation or as per the customer's preference.

1. If the cabinetry you are using does not have a panel reveal depth of 5/8", you may have to perform one of the following two procedures to ensure flush mounting :
 - a. remove the "mounting slides" if the cabinetry is too shallow or,
 - b. use a shim if it is too deep.
2. Slide the CIP tray into the cabinet and attach the slide shims of the tray using the (4) 12-24x pan head Phillips screws on the two innermost Tinnerman clip positions (see Figure 4-3).

NOTE: These instructions will have to be interpreted broadly when using another manufacturer's cabinetry.

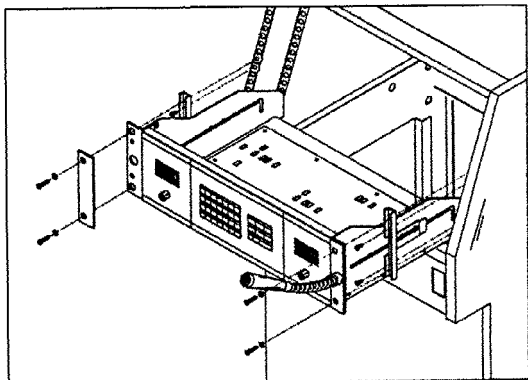

Figure 4-3 CIP TRAY WITH MICROPHONE

3. After the CIP tray is mounted, connect the following cables using Table 4-5.
4. Mount the panel microphone (TDV-OP402/HR) to the CIP:

All other microphone options, i.e., Dual Arm Boom Microphone (TDV-OP403), Desk-Top Microphone (TDV- OP404), and Auxiliary Microphone Location (TDV-OP405), have customer specific installation requirements and will not be included in this Installation Guide.

Table 4-5 CIP TRAY CABLE CONNECTIONS

CIP Tray Board Connections (A1709228)		CIP PS Line Term Board Connections (A1709230)
1st Line Term Cable - P9 (I/O 1)	Connect to	P1 (I/O 1)
2nd Line Term Cable - P6 (I/O 2)	Connect to	P1 (I/O 2)
Red/Black CIP Power Cable	Connect to	P2 (13.7V DC) on CIP Tray
Ground Cable (A600966.18) The ground cable is attached to the center Pem nut on the rear of the CIP tray.	Connect to	CIP Power Supply Remove the 5-32x1/2 Philips head screw at location marked with a ground symbol on the rear of the power supply and attach the ground cable.

This page intentionally left blank.

SECTION 5 CRT-BASED ELECTRONICS ASSEMBLY PART II

5.1 INTRODUCTION

If you have ordered a CRT-Based console system installed in E.F. JOHNSON cabinetry, most of the assembly will already have been done at the factory. This section, CRT-Based Electronics Assembly - Part II, details the additional assembly required for either a complete E.F. Johnson CRT-Based system or an Electronics Only CRT- Based system.

5.2 INSTALL THE PC AND UPS

Table 5-1 PC UPS OPTIONS

PC CPU Part No.	200TC4862501
Possible option numbers for the PC UPS	
Part Number	Country
TDV-OP400/A	North America
TDV-OP400/GB	Great Britain, S. Africa
TDV-OP400/E	Europe
TDV-OP400/I	India
TDV-OP400/NZ	New Zealand/Australia

- Remove the two bottom screws of the PC CPU (holding the PC cover together) and completely slide the PC CPU into the PC tray bracket.
- Replace the two screws that were removed with two (2) 6-32x1/2 pan head Phillips screws (furnished).

- Place the PC UPS (TDV-OP400/XX) onto the swivel mount so that the feet engage the holes. Refer to Figure 4-1.

5.3 CONNECT THE PC CPU AND PC UPS POWER CORDS

Part Numbers:

PC UPS - TDV-OP400/xx

PC CPU - 200TC4862501

Refer to Figure 5-1.

- Connect one end of the supplied power cord to the PC CPU. Plug the other end into the top left receptacle at the rear of the PC UPS. (Coil up the excess cable and secure).
- Connect one end of the other supplied power cord to the PC UPS. Plug the other end into the customer-furnished receptacle box feeding the console. (Leave enough slack on the power cord so that it will not unplug when the tray is fully extended).

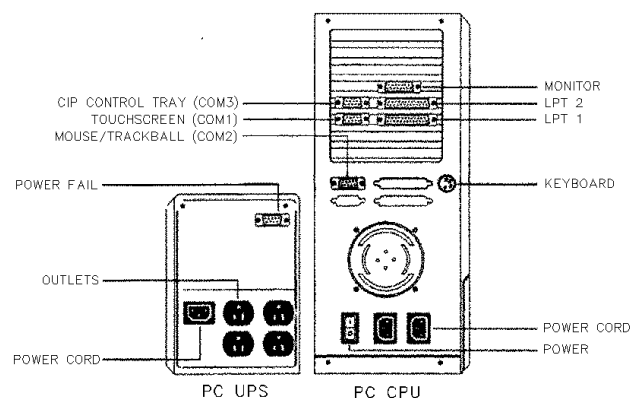

Figure 5-1 CPU AND UPS POWER CONNECTIONS

5.4 CONNECT THE CRT INTERFACE PROCESSOR (CIP) TRAY CABLES

Refer to Figure 5-2 and Table 5-2.

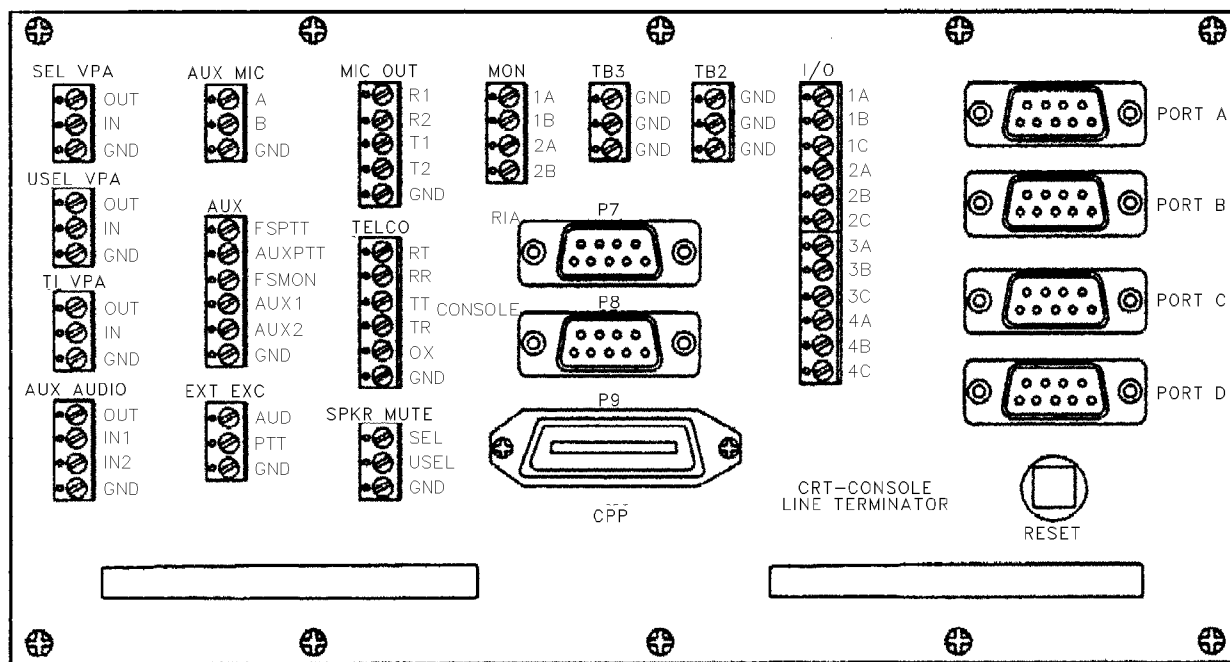

Figure 5-2 CIP POWER SUPPLY LINE TERM BOARD - A1709230

Table 5-2 CRT CABLE CONNECTIONS

CIP Power Supply Line Term Board (A1709230) Cable Connections		
Footswitch Cable (A210906) Red to AUX-FSPTT (TB11) Green to AUX-FSMON (TB11) Black to AUX-GND (TB11)	Connect to	Footswitch Jack Mounts in the 5/8" hole at the base of the bay where the CIP is installed. If there is no hole, provide one.
Power Fail Cable (A2109116) Green to AUX-AUX1 (TB11) Red to AUX-AUX2 (TB11) Black to AUX-GND (TB11)	Connect to	PC UPS (see Figure 5-1) POWER FAIL connector
Console Serial Cable (A600991.6) P8 (CONSOLE)	Connect to	PC CPU (see Figure 5-1) COM 3 (CIP Control Tray) connector

5.5 INSTALL THE CRT MONITOR

5.5.1 CRT MONITOR CONNECTIONS

Refer to Figure 5-1.

1. Plug the female end of the IEC cord into the CRT monitor.
2. Plug the other end of the IEC cord into the 2nd top outlet on the PC UPS.

NOTE: Leave enough slack on the power cable so that it will not unplug when the tray is fully extended.

3. Connect the VGA connector from the monitor to the "Monitor" port on the PC CPU.

5.5.2 ADDITIONAL CONNECTION FOR A 17 " OR 21 " IDEK MONITOR

1. Connect the RGB cable to the 15 pin connector on the rear of the CRT monitor.
2. Connect the VGA connector from the monitor to the "Monitor" port on the PC CPU.

5.6 INSTALL CRT TOUCHSCREEN (Option TDV-OP492)

NOTE: Skip Steps 1 and 2 if the Touchscreen has already been mounted on the monitor.

5.6.1 MOUNT TABS

The Touchscreen is shipped with mounting tabs that have been installed on the front of the CRT monitor at the factory. In the event that they were not installed, perform the following:

1. Slide the CRT Touchscreen onto the CRT monitor and hold it firmly in place. Transfer the two side holes on the Touchscreen to the CRT monitor by marking with a thin sharp-pointed pencil.
2. Remove the paper from the back of the tabs to expose the adhesive surface. Place the tabs firmly on the pencil-marked holes.

5.6.2 INSTALL THE TOUCHSCREEN

Install the Touchscreen: Place the Touchscreen onto the monitor, slipping the sides of the touchscreen over the tabs you just installed, as shown in Figure 5-3.

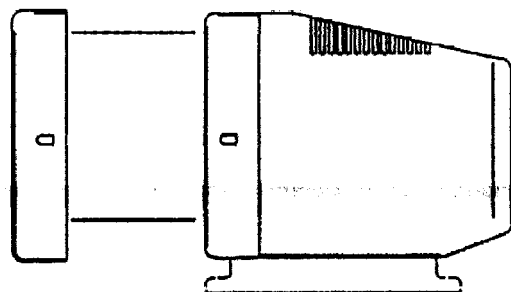

Figure 5-3 TOUCHSCREEN INSTALLATION

5.6.3 CONNECT THE TOUCHSCREEN CABLES

Two cables, already attached to the Touchscreen, have to be connected to the CIP Power Supply and CPU as follows:

1. Connect the touchscreen power cable (mini DIN type) to the CIP PS mini DIN connector as shown in Figure 5-4.
2. Connect the data cable (DE9-M) to the PC CPU (COM 1). Refer to Figure 5-1.
- 3.

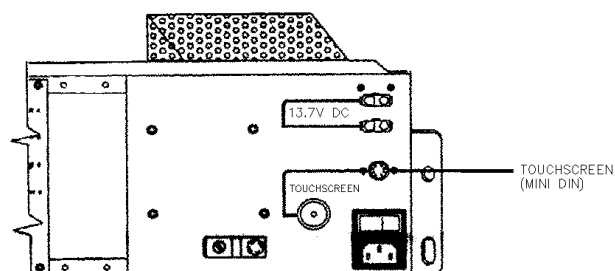

Figure 5-4 CABLE CONNECTION TO CIP PS

5.7 INSTALL CRT TRACKBALL OPTION/ MOUSE OPTION

TRACKBALL OPTION - TDV-OP490
MOUSE OPTION - TDV-OP491

Plug the DE9-M connector into the PC CPU (COM 2) Mouse/Trackball DIN. Refer to Figure 5-1.

5.8 INSTALL HEADSET JACK (Options TDV-OP406, 407, 409)

This installation applies for either one or two headset jacks.

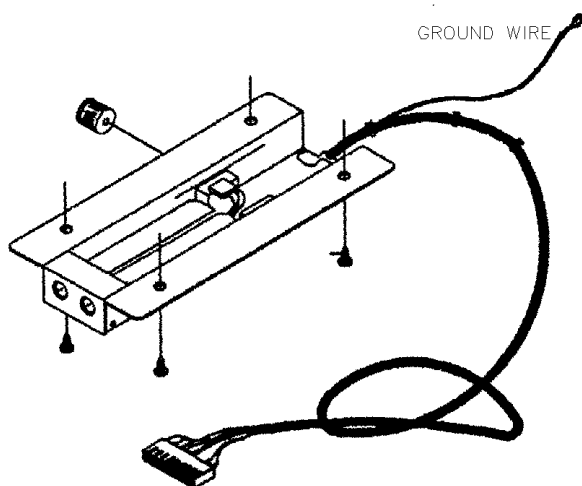

Figure 5-5 HEADSET JACK

1. Mount the headset jack(s) to the Formica writing surface in the location desired using the four #10 flakeboard screws (280SCSM0112P) provided.
2. **VERY IMPORTANT!** Connect the ground wire, located at the rear of the headset, to the rail of the console supporting the Formica using the 8-32x1/2 pan head Phillips screw and 8-32 nut attached to the ground wire. Refer to Figure 5-5.
3. Plug the connector end(s) of the headset jack(s) into the CIP board. Connect the first headset to P4(HSJ I/O 1) and the second headset to P5(HSJ I/O 2). Refer to Figure 5-6.

4. Install the black trim strip (141230970A).
5. Secure the tray using the four 12-24x1" black truss head screws (280129122406) and #12 black nylon washers (280359120010) provided.

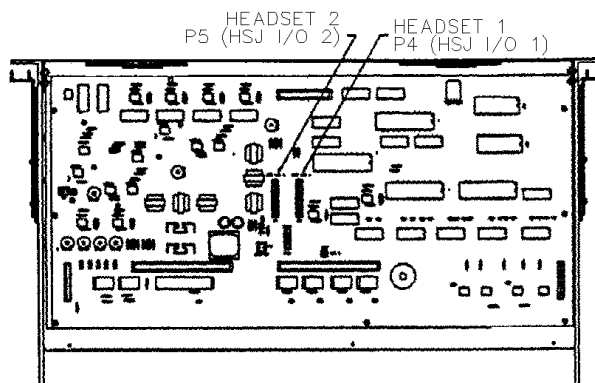

Figure 5-6 CIP BOARD

5.9 INSTALL SECOND VOLUME CONTROL KNOB

TDV-OP409 (Electronic 1A2 TELCO Headset) will be equipped with two volume control knobs. The volume control knob mounted on the right side, controls the radio audio to the headset. The volume control knob mounted on the left, controls the audio from the enhanced TELCO.

IMPORTANT

Option TDV-OP409 provides two volume control knobs. If your system does not include option TDV-OP407 (second headset jack), store the leftover parts from TDV-OP409 for a future order of a second headset.

Table 5-3 VOLUME CONTROL HARDWARE

Qty	Part No.	Description
1	240FPV12BA1	Volume Control Knob
1	4751904Z5001	5k Pot

NOTE: If the system was ordered with TDV-OP409, these steps will have been done at the factory. If the option was ordered after delivery, these steps will have to be performed to install the second volume control knob. Refer to Figure 5-5.

1. Remove the hole plug from the left side of the headset jack housing.
2. Install the volume control (4751904Z5001) in the housing in the place of the hole plug.
3. Connect the three pin molex connector, located on the end of the wire harness, to the volume control. This connector can only be connected one way. Caution: Be careful not to bend pins when making the connection.
4. Attach the volume control knob (240FPV12BA1).

5.10 SET UP AND OPERATION OF THE HEADSET JACK

The headset jack is equipped with a switch on both sides of the unit. These switches are slightly recessed to prevent accidental movement. The switch on the right, as shown in Figure 5-7, is used for selecting 4W/6W operation. Four wire (4W) headsets do not have a push-to-talk (PTT) switch.

WARNING

If a 4 wire headset is plugged into the jack when it is set for 6 wire operation, the channel will instantly key up and remain on until the headset is unplugged.

The switch on the left, as shown in Figure 5-7, is typically used for training purposes. In the MIC On position, the headset MIC and earpiece are active for normal dispatch operation. In the MIC Off position, the headset earpiece is active but the MIC is disabled for use by a trainee in parallel with a trained operator.

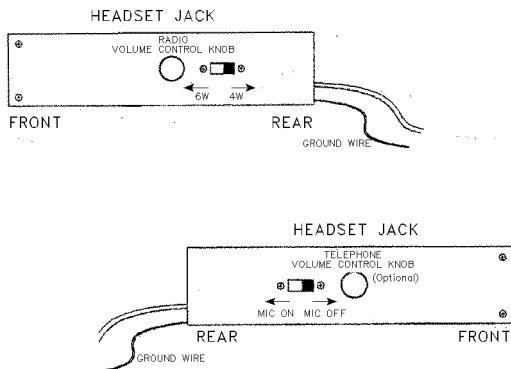

Figure 5-7 CONNECTOR HEADSET

5.11 CONNECTING A TELEPHONE INSTRUMENT TO THE TELCO INTERFACE

The telephone instrument must be headset compatible. The instrument must have a separate mic path and earpiece path. The telephone instrument should also provide a contact closure output when a line is selected. If the telephone does not have this capability, a key on the Radio Control Panel may be programmed to switch from Radio to Telephone but this is not a preferred method of operation.

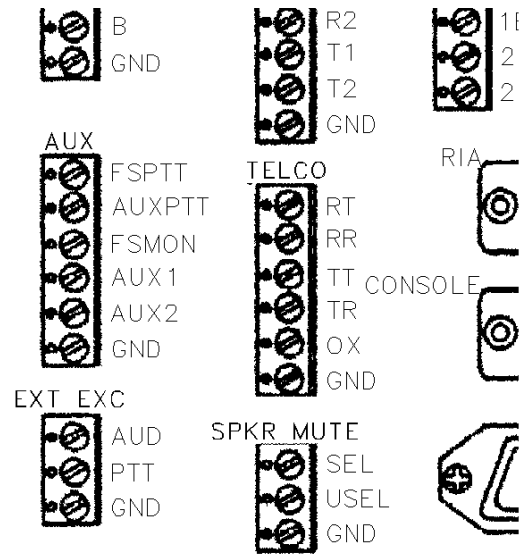

Figure 5-8 TELCO CONNECTION TO CIP PS

Note the following abbreviations: TT and TR are abbreviations for Talk Tip and Talk Return. RT and RR are abbreviations for Receiver Tip and Receiver Return. OHS is an abbreviation for Off-Hook Sense. GND is an abbreviation for logic GROUND. Refer to Figure 5-8, Line Term Board A1709230.

1. Connect the Microphone Input to the telephone instrument to terminals TT and TR of the CIP Line Term Board, A1709230.
2. Connect the Receiver Output from the telephone instrument to terminals RT and RR of the CIP Line Term Board, A1709230.
3. Connect the Line Select contact closure output from the telephone instrument to terminals OHS and GND of the CIP Line Term Board, A1709230.

This page intentionally left blank.

SECTION 6 EQUIPMENT CHECK-OUT AND ADJUSTMENTS

6.1 INITIAL POWER-UP AND CHECK-OUT

IMPORTANT

Be sure AC power is available at the outlets. If the CPP or console(s) are turned on without AC power available, their internal UPS batteries will power the system until they are depleted.

1. Turn-on the printer and modem before powering-up the system.
2. Turn on the CPP power using the rocker switches on the front of each power supply.

If the Power Fail LED lights, press the RESET switch on the top of the power supply as shown in Figure 5-2. [Probable Cause: A magnetic latch is used to transfer AC from the main to the reserve power supply. A sufficiently hard bump in transit can cause the magnet to drop to the reserve position.]

3. Visually observe each card in the CPP.

The green and red LEDs should light as soon as power is applied. Within a few seconds, all red LEDs should be extinguished. Yellow LEDs will be lit on any cards designated a hot-standbys.

If red LEDs are lit on any CPP cards after an interval of 10 seconds, press the RESET button on that card and wait for the red LED to extinguish.

If the red LED continues to be illuminated, contact E.F. Johnson Technical Support for assistance.

Check to see that all CPP cards are properly seated and all plug-in relays are fully seated in their sockets.

If all CPP cards have green LEDs illuminated and there are no red LEDs illuminated, it may initially be assumed that the system is functioning properly.

4. Check the Printer Output Report. n The printer should begin to print the startup log immediately upon power-up. This printout will require several seconds to complete. Large systems may require nearly a minute to complete the report.

Check the printed report for any failure or error messages. If the individual consoles are not powered at the time of startup, off-line/failure messages will be printed for those consoles.

5. Plug in DC Appliqu's.

To avoid accidental electric shock while initially working on the system, all LIC cards configured for DC control are shipped with the DC appliqu's unplugged. Before placing the card in service, the ribbon cable from the appliqu must be plugged into P1 on the LIC card.

WARNING

With the DC appliqu's connected, as much as 200 volts may be present in the LIC card and the RTL control pairs. Use Extreme Caution!

6. Apply power to the Consoles. n Apply power to the individual console positions using the rocker switches on the front of each power supply.

Within 10 seconds of power-up, the console should establish communications with the CPP.

The clock will display "????". n When console/ CPP communications are established, the clock will display the time generated by the CSC real time clock. Note particularly the seconds readout. If the console is communicating properly with the CPP, the seconds count will advance smoothly with no gaps or delays.

As individual consoles are powered-up, the printer will log a report for each control tray and module tray at the position.

7. Observe the LEDs on the channel modules. On module-based consoles, each channel module should have either the yellow or green LED adjacent to the volume control on.

Touch the volume control cap on individual channel modules. The LEDs should toggle smoothly between yellow and green, with no delay as the cap is touched.

In normal operation, auxiliary switch and paging modules may show no indications until the function is actually used. Think before you press buttons! You could interfere with other operations or accidentally set off pagers and sirens.

8. If at this point, the CPP and all console positions appear to be performing normally, proceed ahead to level setting and point by point testing.

NOTE: The system should be allowed to "burn-in" for a minimum of 72 hours, before being placed into actual service, to allow any possible "infant mortality" problems to surface and be resolved.

6.2 CPP ADJUSTMENTS

The only level to be adjusted in the CPP is the Tx Output from each Line Interface Controller. Rx levels are automatically adjusted under processor control. The initial Tx and Rx level settings are factory adjusted and programmed in accordance with the data furnished to E.F. Johnson at the time of order. Tx levels should be set using industry standard techniques for 600W balanced line audio.

NOTES:

The receive input for each channel will be programmed for either 2 wire or 4 wire audio input in accordance with the data furnished at the time of order. The 2 wire receive audio path is disabled on any channel specified by the customer as having a 4 wire interface.

All DC controlled channels are shipped with the DC current generator applicu board disconnected to prevent accidental electric shock injury to the installer. These applicu s must be plugged in prior to testing any DC controlled channels.

The Tx and Rx levels between the CPP and the Console are fixed and cannot be adjusted. The nominal level is 0 dBm across 600W. If the console is being operated through a Remote Interface Adapter (RIA), level adjustment is automatically maintained through ALC amplifiers.

6.3 CONSOLE ADJUSTMENTS

There are several control adjustments that can be made to optimize the performance of the console. These adjustments are located on the right side of the control tray when viewed from the front of the console.

Panel Microphone

The sensitivity of the panel (or primary) microphone is adjusted by the MIC 1 control, R11. This control should be adjusted to just below the knee of compression for a typical operator speaking in a normal voice at the normal working distance from the microphone. If set too high, the mobile units will complain about excessive background noise and a "barrel" quality to the dispatcher's voice. This is caused by excessive compressor action on the control tray.

NOTE: The MIC 1 and MIC 2 controls are SENSITIVITY adjustments, not OUTPUT adjustments. The audio level from the tray is fixed and cannot be increased through the use of these controls.

Auxiliary Microphone

If the console is equipped with an Auxiliary (or secondary) microphone, such as a desk microphone at an NCIC terminal, its sensitivity can be adjusted by the MIC 2 control, R16. See the paragraph above for details.

Headset Transmit

The transmit sensitivity of the headset lipmicrophone is adjusted by the HS control, R6. Note that many amplified headsets have an internal compressor as part of the headset mic circuitry. Be sure the console HS control is set just below the knee of compression to avoid double or constant compression.

Headset Receive Limit

The receive audio sensitivity and the method of handling audio overload varies widely among headset manufacturers. To avoid dispatcher complaints about excessive receive background noise, use the following procedure to set the headset receive limit:

Inject a tone into the Rx port of an available LIC card and Select the channel.

Turn the radio headset jack volume control to its maximum (loudest) setting.

If the headset amplifier has a volume control and/or volume switch, set them to maximum.

Locate the Headset Limit control (HS LIM) on the Selected Audio speaker amplifier board. Turn this control to its maximum setting. While listening to the tone, slowly turn this control down until you hear the output from the headset earpiece just begin to decrease. Set the control slightly above this point such that the headset is just into compression with its volume controls at maximum. The headset jack radio volume control and any controls on the headset itself can be used to adjust the volume to each operator's preference.

TELCO Level Adjustments

TDV-OP409 is an electronic interface which provides amplification and adjustments for the receive level. Refer to the VR-CM50 Console Service Manual, Volume 1, CRT- Technical Manual Section , for jumper configuration settings.

External Encoder

If the console is equipped with an external paging encoder (such as ZETRON), the input sensitivity is adjusted by the ENCDR control, R33. There is no signal compression in the external encoder audio path. If the data furnished to E.F. JOHNSON at the time of order did not specify the use of an external encoder, the port on the tray will not be programmed to be active.

NOTE: The ENCDR control does not affect the output of the internal keypad encoder on the control tray. Paging tones are actually generated on the LIC card, not in the control tray.

Telephone Ringer

If the console is equipped with the Integrated Telephone Screen option, the internal telephone ringer volume can be set by the S MIX control, R86.

6.4 ALIGN THE CRT TOUCHSCREEN WITH THE PC COMPUTER

If your system is equipped with a touchscreen option (TDV-OP492/xx), the touchscreen must be calibrated for the specific monitor on which it is installed. Before calibrating the touchscreen, adjust the height, width and position of the CRT image.

1. Return to the Main Screen:

If you are at any other screen but the Main Screen, Press "MAIN" to return to the Main Screen.

2. Access the c:\> prompt:

Press CTRL + 5 using the "5" from the NUMERIC KEYPAD.

c:\orba> will display.

Type cd\ (Enter)

c:\> will display.

3. Begin the Calibration Program:

At the c:\> prompt:

Type "sfcal" (Enter)

Follow the instructions on the screen:

SCREEN 1

TOUCH THE UPPER LEFT POINT USING ONLY ONE FINGER
FINGER SHOULD BE PERPENDICULAR TO SCREEN
HOLD FINGER IN PLACE UNTIL YOU ARE INSTRUCTED TO REMOVE IT

Press ANY key to ABORT calibration

SCREEN 2

AFTER PRESSING UPPER LEFT, TOUCH THE LOWER RIGHT POINT USING
ONLY ONE FINGER
FINGER SHOULD BE PERPENDICULAR TO SCREEN
HOLD FINGER IN PLACE UNTIL YOU ARE INSTRUCTED TO REMOVE IT

Press ANY key to ABORT calibration

When the calibration is complete, the message
SF CAL Written, Calibration updated on Installed
SFKERN Driver , will be displayed.

c:\> prompt will display:

4. Initialize the CRT Console:

Reboot the system by pressing the RESET button on
the computer.

The Main Screen will then be displayed.

*NOTE: if the Main Screen does not appear, check
the AUTOEXE.BAT file and make sure the drivers
are installed. If they are not, call for technical help
if you do not know how to install them.*

6.5 AFTER SYSTEM CHECK-OUT

At this point, the E.F. Johnson CRT Console system
installation and checkout has been completed. If you
have any questions or problems, contact Technical Sup-
port, 1-800-328-3911. Be sure to complete and mail the
warranty cards for other manufacturer's equipment, such
as the CRT monitor, printer, modem, etc. These can be
found at the back of the VR-CM50 Console Service Man-
ual, Volume 2.

Free Manuals Download Website

<http://myh66.com>

<http://usermanuals.us>

<http://www.somanuals.com>

<http://www.4manuals.cc>

<http://www.manual-lib.com>

<http://www.404manual.com>

<http://www.luxmanual.com>

<http://aubethermostatmanual.com>

Golf course search by state

<http://golfingnear.com>

Email search by domain

<http://emailbydomain.com>

Auto manuals search

<http://auto.somanuals.com>

TV manuals search

<http://tv.somanuals.com>