



Power Pruner™

Operator's Manual

MODELS:

PPF-2100 TYPE 1/1E

Serial Number 001001 - 001162

PPF-2110 TYPE 1/1E

Serial Number 001001 - 001016



WARNING



The engine exhaust from this product contains chemicals known to the State of California to cause cancer, birth defects or other reproductive harm.

WARNING DANGER

Read rules for safe operation and instructions carefully. ECHO provides an Operator's Manual and a Safety Manual. Both must be read and understood for proper and safe operation. Failure to do so could result in serious injury.

X7502302302

89861022662
06/99

INTRODUCTION

Welcome to the ECHO family. This ECHO product was designed and manufactured to provide long life and on-the-job-dependability. Read and understand this manual and the SAFETY MANUAL you found in the same package. You will find both easy to use and full of helpful operating tips and SAFETY messages.

WARNING DANGER

Read rules for safe operation and instructions carefully. ECHO provides an Operator's Manual and a Safety Manual. Both must be read and understood for proper and safe operation.

THE OPERATOR'S MANUAL --

contains specifications and information for operation, starting, stopping, maintenance, storage and assembly specific to this product.

THE SAFETY MANUAL —

explains possible hazards involved with the use of Power Pruner™ and what measures you should take to make their use safer.

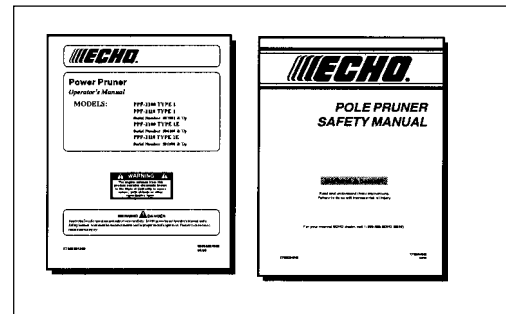

TABLE OF CONTENTS

- Introduction 2
 - The Operator's Manual 2
 - The Safety Manual 2
- Manual Safety Symbols & Important Information 3
- Safety 3
 - General Description 3
 - Decals 4
 - International Symbols 4
 - Equipment 4
 - Fuel 5
 - Personal Condition & Safety Equipment 6
 - Safe Operation 7
 - Kickback 8
 - Extended Operation/Extreme Conditions 9
- Description 10
 - Contents 10
 - Emission Control 10
- Specifications 13
- Assembly 14
 - Cutting Attachment to Drive Shaft Installation 14
 - 3' Extension Installation 14
 - Saw Chain Tension Adjustment 15
- Pre-Operation 16
 - Fuel 16
 - Lubricating the Guide Bar and Saw Chain 17
 - Adjusting Automatic Oiler 17
 - Equipment Check 18
 - Determine Operation Area 18
- Operation 19
 - Starting Cold Engine 19

- Starting Warm Engine 20
- Stopping Engine 20
- Pruning Techniques 21
- Maintenance 21
 - Skill Levels 21
 - Maintenance Intervals 22
 - Air Filter 23
 - Fuel Filter 23
 - Spark Plug 24
 - Cooling System Cleaning 24
 - Exhaust System 25
 - Carburetor Adjustment Emissions 26
 - Carburetor Adjustment Non Emissions 27
 - Guide Bar and Saw Chain Replacement 28
 - Filing Saw Chain 29
- Troubleshooting 30
- Storage 31
- Servicing Information 32
 - Parts 32
 - Service 32
 - ECHO Consumer Product Support 32
 - Warranty Card 32
 - Additional or Replacement Manuals 32
 - Manual Ordering Instructions 32

Specifications, descriptions and illustrative material in this literature are as accurate as known at the time of publication, but are subject to change without notice. Illustrations may include optional equipment and accessories, and may not include all standard equipment.

MANUAL SAFETY SYMBOLS & IMPORTANT INFORMATION

Throughout this manual and on the product itself, you will find safety alerts and helpful, information messages preceded by symbols or key words. The following is an explanation of those symbols and key words and what they mean to you.



This symbol accompanied by the words **WARNING** and **DANGER** calls attention to an act or condition that can lead to serious personal injury to operator and bystanders.



The circle with the slash symbol means whatever is shown within the circle is prohibited.



IMPORTANT The enclosed message provides information necessary for the protection of the unit.

NOTE This enclosed message provides tips for use, care and maintenance of the unit.

SAFETY

GENERAL DESCRIPTION

IMPORTANT

See Description and Specification sections for full description and illustration of model variation in power head, and handle type.

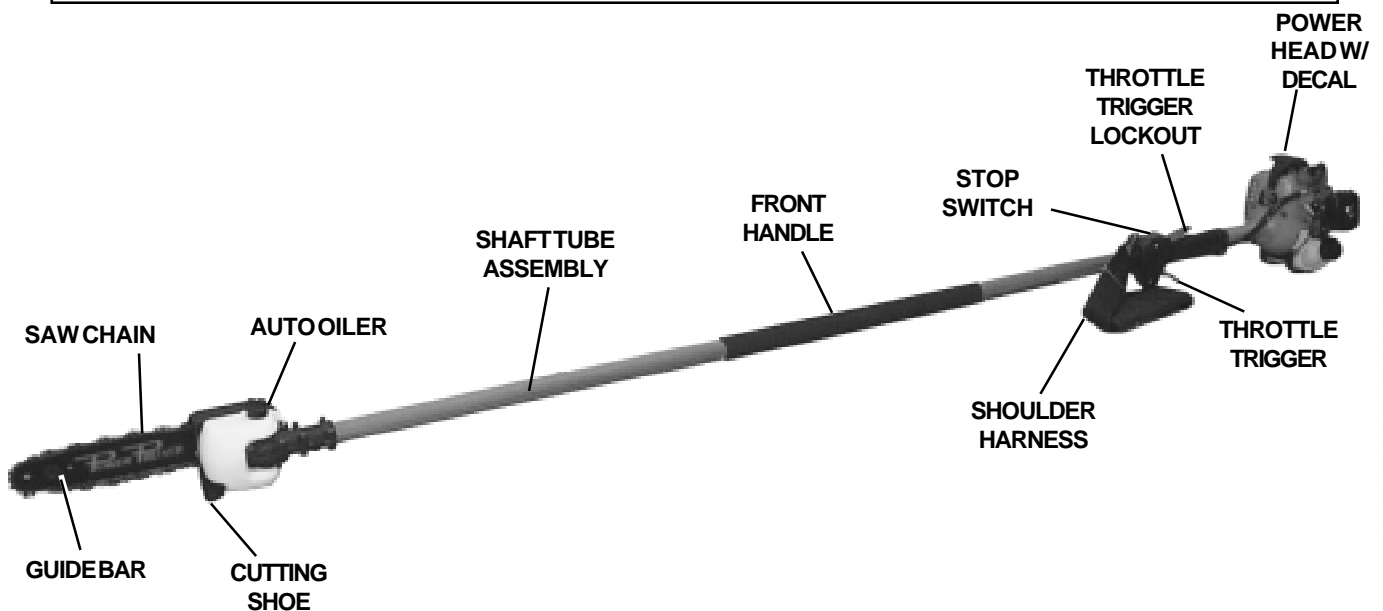

DECALS

Locate this safety decal on your unit. The complete unit illustration found in the "DESCRIPTION" section, will help you locate them. Make sure the decals are legible and that you understand and follow the instructions on them. If a decal cannot be read, a new one can be ordered from your ECHO dealer. See PARTS ORDERING instructions for specific information.

Engine Cover

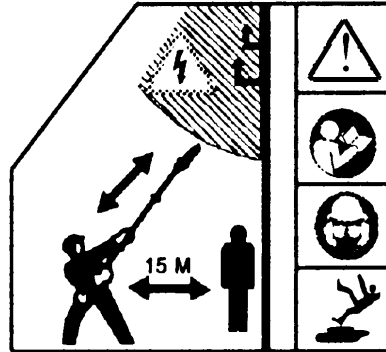

INTERNATIONAL SYMBOLS

Symbol form/shape	Symbol description/application	Symbol form/shape	Symbol description/application
	Read and understand Operator's Manual.		Fuel and oil mixture
	Wear eyes, ears and head protection		Finger Severing
	Hot Surface		Wear hand protection. Use two handed.
	Safety/Alert		DO NOT smoke near fuel.
	Avoid all power lines. This unit is not insulated against electrical current.		Do not operate closer than 15 M (50 ft.) from electrical hazards.
	Keep bystanders at least 15 meters (50 feet) away.		Plan retreat path from falling objects.

Symbol form/shape	Symbol description/application	Symbol form/shape	Symbol description/application
	DO NOT allow flames or sparks near fuel.		Wear slip resistant foot wear.
	Engine choke control.		Ignition ON/OFF
	Emergency stop		Primer bulb
	Chain lubrication		Carburetor adjustment - High speed mixture
	Carburetor adjustment - Low speed mixture		Carburetor adjustment - Idle speed

EQUIPMENT

Before operation a complete check of the unit must be performed;

- Check unit for loose/missing nuts, bolts and screws. Tighten and/or replace as needed.
- Inspect fuel lines, tank and area around carburetor for fuel leaks. DO NOT operate unit if leaks are found.
- Never adjust the guide bar or saw chain when the engine is operating.

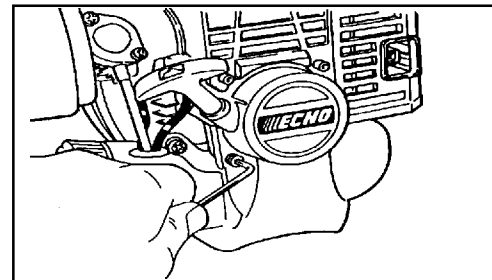

Guide Bar and Saw Chain

WARNING  **DANGER**

- Serious injury may result from the use of non approved guide bar and saw chain combinations. Read and comply with all safety instructions listed in this manual.
- ECHO, INC. will not be responsible for the failure of cutting devices or accessories which have not been tested and approved by ECHO for use with this unit.

- Check that the cutting attachment, guide bar and saw chain is firmly attached and in safe operating condition.
- Only use ECHO approved guide bar and saw chain.
- Only use one ECHO approved extension on the pruner.
- Do not hit rocks, stones, tree stumps and other foreign objects with the saw chain.
- Do not cut into the ground with the saw chain.
- If cutting attachment end strikes an obstruction, stop engine immediately and inspect saw chain for damage.
- Do not operate with a dull, fractured or discolored saw chain.
- Remove all foreign objects from work area.
- Always cover the guide bar and saw chain with guide bar cover during transportation and in storage.



FUEL

WARNING  **DANGER**

Fuel is **VERY** flammable. Use extreme care when mixing, storing or handling, or serious personal injury may result.

- Use an approved fuel container.
- **DO NOT** smoke near fuel.
- **DO NOT** allow flames or sparks near fuel.
- Fuel tanks/cans may be under pressure. Always loosen fuel caps slowly allowing pressure to equalize.
- **NEVER** refuel a unit when the engine is **HOT!**
- **NEVER** refuel a unit with the engine running.
- **DO NOT** fill fuel tanks indoors. **ALWAYS** fill fuel tanks out doors over bare ground.
- Securely tighten fuel cap after refueling.
- Inspect for fuel leakage. If fuel leakage is found, do not start or operate unit until leakage is repaired.



After Refueling;

- Wipe any spilled fuel from the unit.
- Move at least 3 M (10 ft.) from refueling location before starting.

After Use;

- **DO NOT** store a unit with fuel in its tank. Leaks can occur. Return unused fuel to an approved fuel storage container.

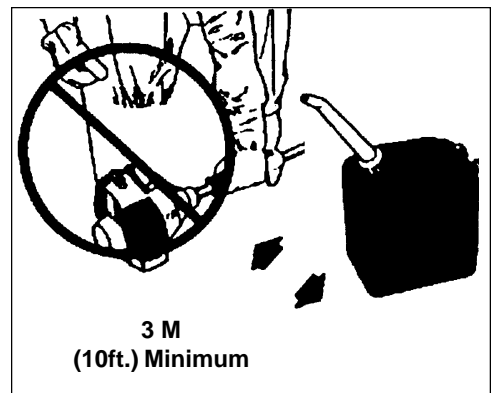

PERSONAL CONDITION & SAFETY EQUIPMENT

WARNING DANGER

Power Pruner™ users risk injury to themselves and others if the Power Pruner™ is used improperly and or safety precautions are not followed. Proper clothing and safety gear must be worn when operating a Power Pruner™.

Physical Condition --

Your judgment and physical dexterity may not be good:

- if you are tired or sick,
- if you are taking medication,
- if you have taken alcohol or drugs.

Operate unit only if you are physically and mentally well.

Eye Protection --

Wear eye protection that meets ANSI Z87.1 or CE requirements whenever you operate the Power Pruner™.

Face & Head Protection --

When trimming overhead, always wear head protection meeting ANSI Z89.1 or CE requirements with a full face shield. Head protection with full face shield will help protect you from falling branches and debris.

Hand Protection --

Wear no-slip, heavy duty work gloves to improve your grip on the Power Pruner™ handles. Gloves also reduce the transmission of machine vibration to your hands.

Hearing Protection --

ECHO recommends wearing hearing protection whenever unit is used.

Proper Clothing --

Wear snug fitting, durable protective clothing; chain saw safety pants or chaps are recommended.

- Pants should have long legs, shirts with long sleeves.
- **DO NOT WEAR SHORTS,**
- **DO NOT WEAR TIES, SCARVES, JEWELRY.**

Wear sturdy protective safety shoes or boots with non-skid soles;

- **DO NOT WEAR OPEN TOED SHOES,**
- **DO NOT OPERATE UNIT BAREFOOTED.**

Hot Humid Weather --

Heavy protective clothing can increase operator fatigue which may lead to heat stroke. Schedule heavy work for early morning or late afternoon hours when temperatures are cooler.

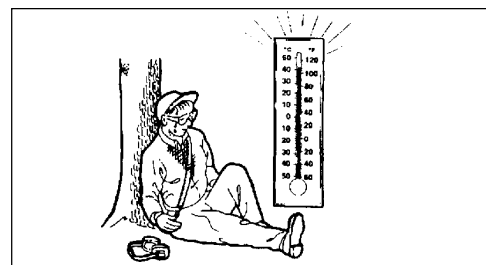
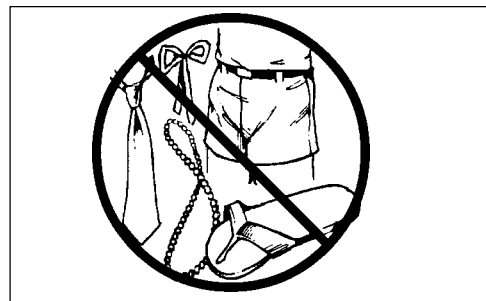
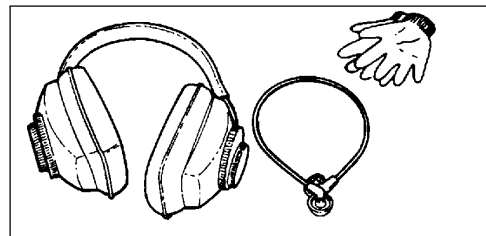
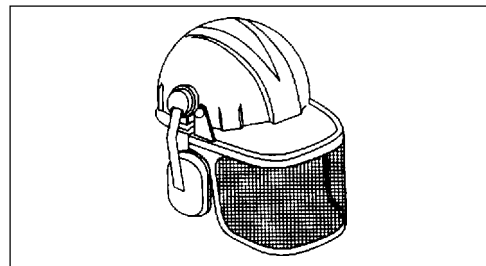

SAFE OPERATION

WARNING  DANGER

All over head electrical conductors and communications wires can have electricity flow with high voltages. Never touch wires directly or indirectly when pruning, otherwise serious injury or death may result.

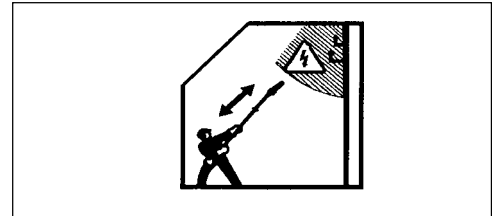

Determine Operation Area

- Provide all operators of this equipment with the Operator's Manual, and instructions for safe operation.
- Do not operate this product indoors or in inadequately ventilated areas.
- Review the area to be trimmed. Look for hazards that could contribute to unsafe conditions. **DO NOT** operate unit if any wires (power, telephone, cable, etc.) are closer than 15 M (50 ft.) to any part of the operator or unit.
- Spectators and fellow workers must be warned, and children and animals prevented from coming nearer than 15 M (50 ft.) while the Power Pruner™ is in use.
- Avoid all power lines. This unit is not insulated against electrical current.

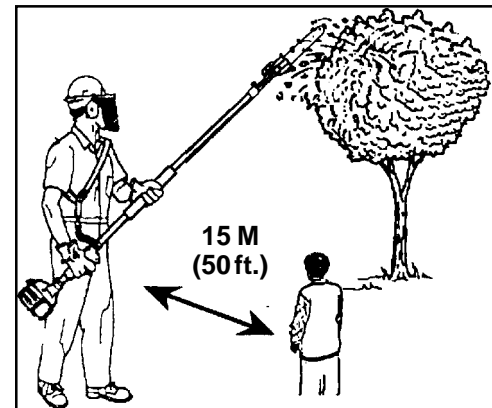

Operation

Use Proper Clothing & Equipment

- Before starting the unit, equip yourself and any other person working within the 15 M (50 ft.) Safety Zone with the required Protective Equipment and clothing.
- Always wear head protection with full face shield to help protect against falling branches and debris.

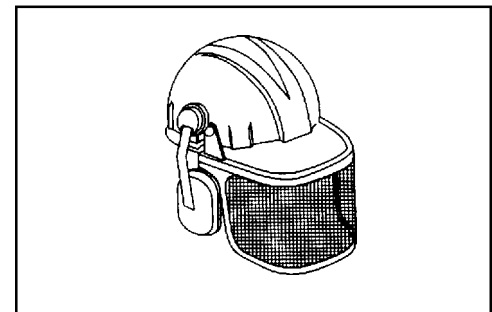

Avoid Hot Surfaces

- During operation, the complete unit, especially the power head, muffler area and cutting attachment may become very hot, too hot to touch. Avoid contact during and immediately after operation.

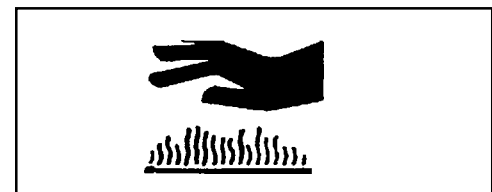

Keep A Firm Grip

- Grip Power Pruner™ with both hands with thumbs and fingers encircling the handle, and shaft tube.

Keep A Solid Stance

- Maintain footing and balance at all times. Do not stand on slippery, uneven or unstable surfaces. Do not work in odd positions or on ladders. Do not overreach.
- Operate the Power Pruner™ only from the ground or out of an approved bucket lift.
- Always evaluate the branches to be pruned for hazards such as loose dead branches which may fall and strike the operator or helpers. Remove hazards before pruning.
- Plan retreat path from falling objects.
- Cut branches bounce when striking ground.
- Check that shoulder harness is adjusted for safe, comfortable operation. See picture at right for proper adjustment.
- Turn the Power Pruner™ off when moving from tree to tree.
- Avoid any contact with saw chain.

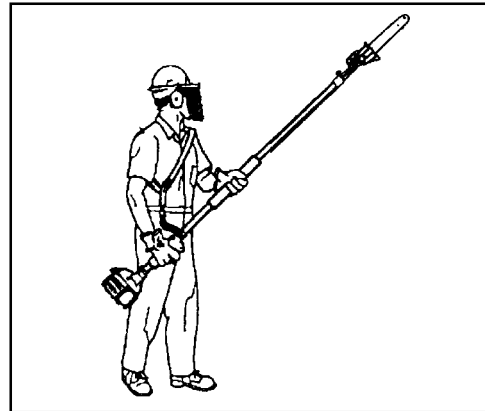

KICKBACK

WARNING DANGER

Kickback can lead to dangerous loss of control of the Power Pruner™ and result in serious injury to the operator or any one standing close by. Hold the Power Pruner™ firmly with both hands with thumbs and fingers encircling the front and rear handles. Be aware of the down and outward path the pruner will take after the cut is made.

Kickback may occur when the moving saw chain at the nose or tip of the guide bar touches an object, or when the wood closes in and pinches the saw chain in the cut. In some cases this may cause a lightning-fast reverse action, kicking the guide bar and saw chain up and back or down and back towards the operator. Either of these reactions may cause the operator to lose control of the Power Pruner™ which could result in serious personal injury.

With a basic understanding of kickback, you can reduce or eliminate the element of surprise which contributes to accidents.

Avoid contact of the guide bar tip with any object while the saw chain is moving.

Cut only wood. Avoid striking concrete, metal, wire, or other obstructions which could cause kickback or damage to the saw chain.

If the saw chain does strike a foreign object, immediately stop the engine, inspect and repair the Power Pruner™ if necessary.

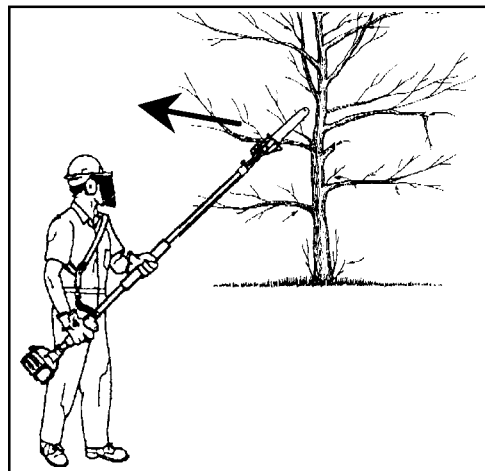

EXTENDED OPERATION/EXTREME CONDITIONS

Vibration and Cold

It is believed that a condition called Raynaud's Phenomenon, which affects the fingers of certain individuals may be brought about by exposure to vibration and cold. Exposure to vibration and cold may cause tingling and burning sensations followed by loss of color and numbness in the fingers. The following precautions are strongly recommended because the minimum exposure which might trigger the ailment is unknown.

- Keep your body warm, especially the head, neck, feet, ankles, hands and wrists.
- Maintain good blood circulation by performing vigorous arm exercises during frequent work breaks and also by not smoking.
- Limit the hours of operation. Try to fill each day with jobs where operating the trimmer or other hand-held power equipment is not required.
- If you experience discomfort, redness and swelling of the fingers followed by whitening and loss of feeling, consult your physician before further exposing yourself to cold and vibration.

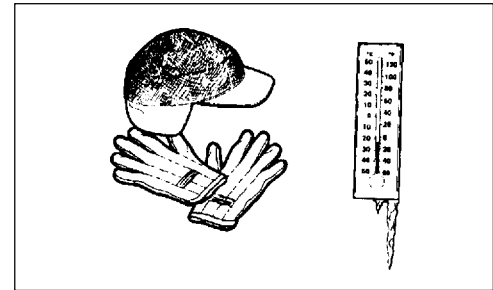

Repetitive Stress Injuries

It is believed that overusing the muscles and tendons of the fingers, hands, arms and shoulders may cause soreness, swelling, numbness, weakness and extreme pain in those areas. Certain repetitive hand activities may put you at a high risk for developing a Repetitive Stress Injury (RSI). An extreme RSI condition is Carpal Tunnel Syndrome (CTS), which could occur when your wrist swells and squeezes a vital nerve that runs through the area. Some believe that prolonged exposure to vibration may contribute to CTS. CTS can cause severe pain for months or even years.

To reduce the risk of RSI/CTS, do the following:

- Avoid using your wrist in a bent, extended or twisted position. Instead try to maintain a straight wrist position. Also, when grasping, use your whole hand, not just the thumb and index finger.
- Take periodic breaks to minimize repetition and rest your hands.
- Reduce the speed and force with which you do the repetitive movement.
- Do exercises to strengthen the hand and arm muscles.
- Immediately stop using all power equipment and consult a doctor if you feel tingling, numbness or pain in the fingers, hands, wrists or arms. The sooner RSI/CTS is diagnosed, the more likely permanent nerve and muscle damage can be prevented.

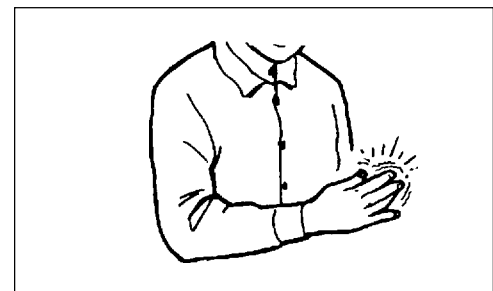
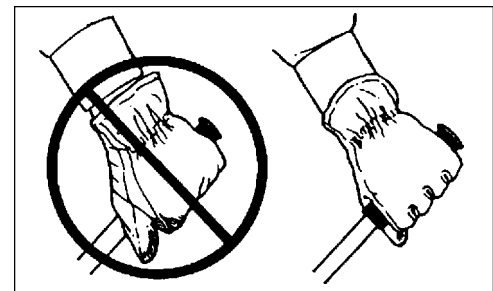

DESCRIPTION

Due to packaging restriction the ECHO product you have purchased requires some assembly.

After opening the carton, check for damage. Immediately notify your retailer or ECHO Dealer of damaged or missing parts. Use the contents list to check for missing parts.

CONTENTS LIST

- ___ Power Head
- ___ Shaft Tube Assembly
- ___ Cutting Attachment
- ___ Plastic Bag
- ___ Operator's Manual
- ___ Safety Manual
- ___ How to Prune Manual
- ___ Warranty Registration Card
- ___ Warranty Statement
- ___ Plastic Bag
- ___ -T-Wrench (Combination screwdriver/
spark plug socket)
- ___ -3 mm Hex Wrench
- ___ Safety Glasses
- ___ Bottle 2-Stroke Engine Oil, 2.6 oz.
- ___ Shoulder Harness
- ___ Guide Bar Cover

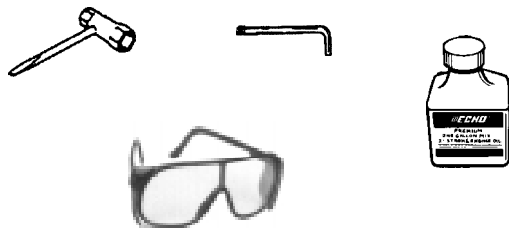

EMISSION CONTROL - Emissions Models

The emission control system for this engine is EM (Engine Modification).

IMPORTANT ENGINE INFORMATION
 ENGINE FAMILY : TEH021UB24RA
 DISPLACEMENT : 21.2cc
 THIS ENGINE MEETS U.S. EPA PHI AND 1995 - 1999 CALIFORNIA EMISSION REGULATIONS FOR ULGE ENGINES. REFER TO OWNER'S MANUAL FOR MAINTENANCE SPECIFICATIONS AND ADJUSTMENTS.



Emission Control Label (located on Engine)
 (EXAMPLE ONLY, information on label varies by FAMILY).

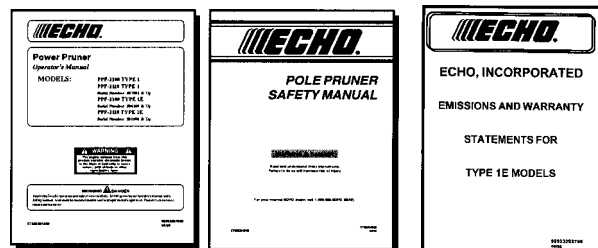

ECHO LIMITED WARRANTY REGISTRATION CARD / CARTA D'INDEGNAMENTO DI GARANZIA LIMITATA			
<small>(Copy of Limited Warranty Statement included with Operator's Manual) / (Copie de l'énoncé de garantie limitée incluse dans le manuel d'utilisation)</small>			
Please Print / Écrivez en caractères d'imprimerie			
Customer Name / Nom du client			
City / Ville		State / État/Province	Zip Code / Code Postal
Dealer / Distributor / No. de concessionnaire		Date of Purchase / Date d'achat	
Model Number / Numéro de modèle		Serial Number / Numéro de série	Engine No. / No. de type
Customer Signature / Signature de client		Dealer Signature (if Applicable) / Signature de concessionnaire (si applicable)	
<p><small>Expediting your purchase enables us to contact you in the unlikely event of a service update on product recall and verify your ownership in the event of theft or loss. / L'expédier de votre achat nous permet de vous contacter dans le cas improbable de modifications des instructions d'entretien ou de report de produit et de vérifier que vous êtes le propriétaire en cas de vol ou de perte.</small></p> <p>OWNER COPY/COPIE DU PROPRIÉTAIRE</p>			
<p>A. Primary use of tool. / Usage principal de l'outil:</p> <p>1. () Professional/Amateur / Professionnel/Particulier 2. () Homeowner / Particulier</p> <p>B. Safety / Operational information received with product. / Informations de sécurité / Fonctionnement fournies avec le produit:</p> <p>1. () Operator's Manual / Manuel d'instructions 2. () Safety Classes / Livres de sécurité 3. () Safety Manual / Manuel de sécurité</p> <p>TO PURCHASE A COPY OF THE ECHO SAFETY VIDEO OVERVIEW, CONTACT / POUR L'ACHETER, IL VOUS SUFFIT DE CONTACTER LA VIDEO DE CONSIGNES DE SÉCURITÉ ECHO. CONTACTER :</p> <p>ECHO, INCORPORATED ATEN, VIDEO CENTER 840 GRANVILLE RD. LAKE ZURICH, IL 60047-1564 U.S.A. 848.1.124.030</p>			

IMPORTANT This spark ignition system complies with Canadian ICES-002

PPF-2100
PPF-2110

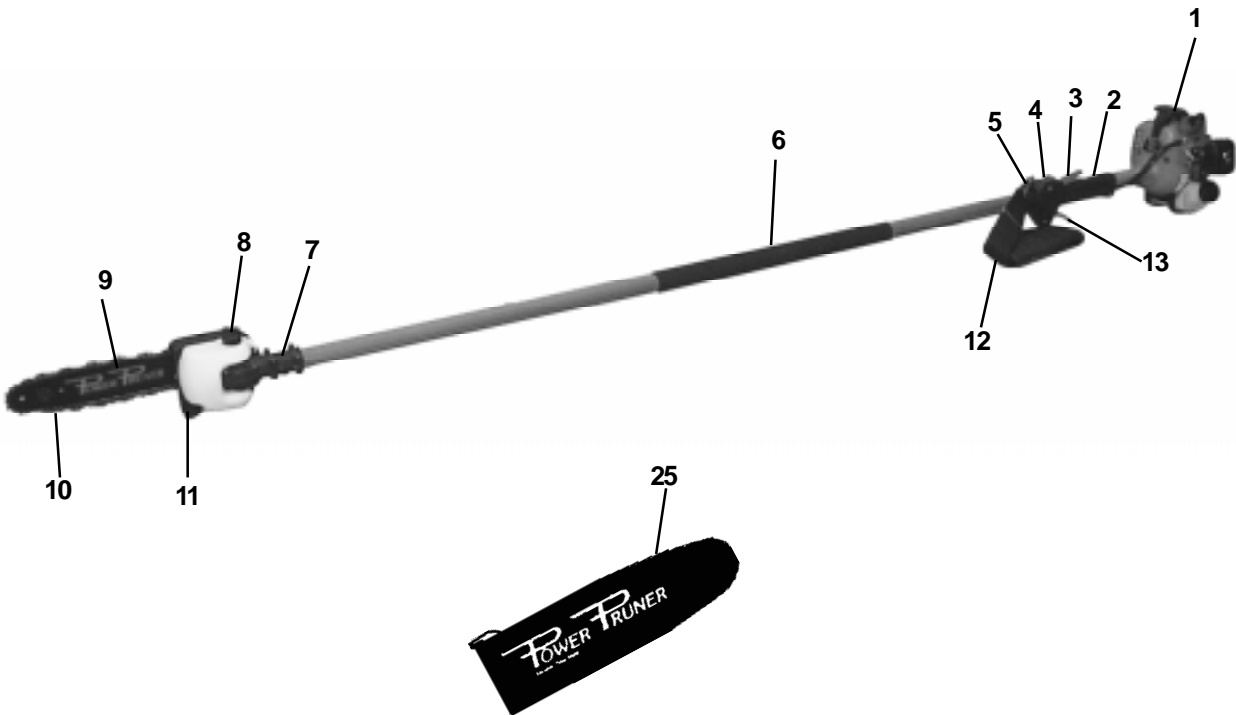
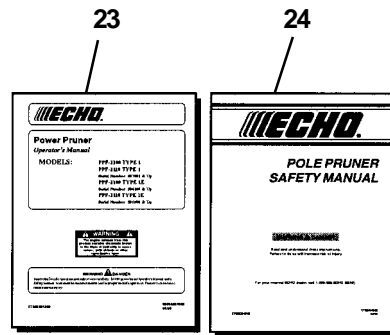
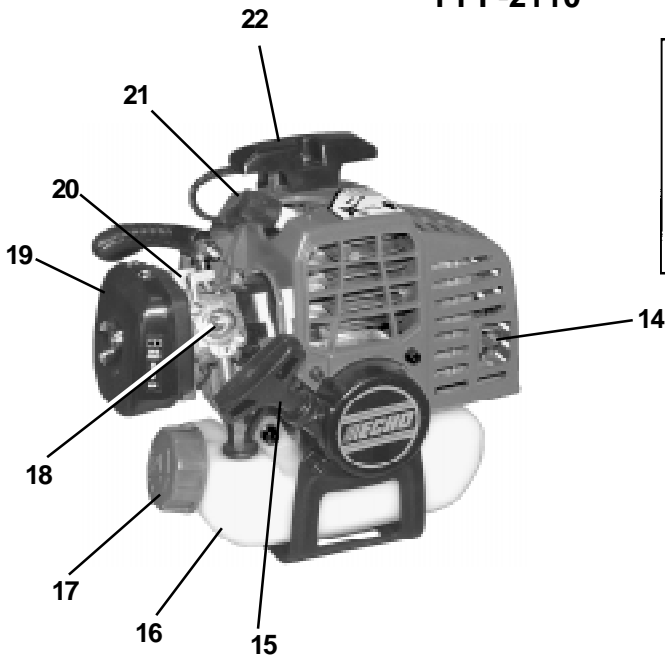

1. **POWER HEAD** - Includes the Engine, Clutch, Fuel System, Ignition System and Starter.
2. **REARHANDLE ASSEMBLY** - Rear (right hand) handle.
3. **THROTTLE TRIGGER LOCKOUT** - This lever must be held during starting. Operation of the throttle trigger is prevented unless throttle trigger lockout lever is engaged.
4. **STOP SWITCH** - Mounted on top of rear handle assembly. Move switch forward to run, back to stop.
5. **STRAP HOOK** - Used to secure unit to shoulder harness.
6. **FRONT HANDLE** - Cushioned grip for left hand.
7. **CUTTING ATTACHMENT** - Sealed, gear ratio is 1.5:1 reduction.
8. **AUTOMATIC OILER ASSEMBLY** - Self oiling. Use high quality, low viscosity, non detergent bar and chain oil.
9. **GUIDE BAR** - 254 mm (10 inch) Bar
10. **SAW CHAIN** - 91 VS 9.53mm (3/8 inch) low profile Oregon® saw chain. Runs approximately 609.6 m/min. (2000 ft/min) at full throttle.
11. **CUTTING SHOE** - Used to capture and stabilize branch while cutting. Place cutting shoe against branch, accelerate and lower saw chain into branch.
12. **SHOULDER HARNESS** - An adjustable strap that suspends the unit from the operator.
13. **THROTTLE TRIGGER** - Spring loaded to return to idle when released. During acceleration press throttle trigger gradually for best operating technique.
14. **MUFFLER, SPARK ARRESTER** - The muffler controls the exhaust noise while the spark arrestor prevents hot, glowing particles of carbon from leaving the muffler where they could possibly start a fire.
15. **RECOIL STARTER HANDLE** - Pull handle slowly until recoil starter engages, then quickly and firmly. When engine starts return handle slowly. **DO NOT** let handle snap back or damage will occur.
16. **FUEL TANK** - Contains fuel and fuel filter.
17. **FUEL TANK CAP** - Covers and seals fuel tank opening.
18. **PRIMER BULB** - Pumping primer bulb before starting engine draws fresh fuel from the fuel tank priming the carburetor for starting. Pump the primer bulb 10 times until fuel is visible in clear fuel return line.
19. **AIR CLEANER ASSEMBLY** - Contains replaceable air filter element.
20. **CHOKE** - Located above air cleaner housing. Move lever to starting position (close choke) and back to run position (open choke).
21. **SPARK PLUG** - Provides spark to ignite fuel mixture.
22. **ARM REST** - Provides arm rest during operation and protects arm from hot engine.
23. **OPERATOR'S MANUAL** - Read and understand this manual before operation. Keep manual in a safe location for future reference, i.e., operation, maintenance, storage and specifications.
24. **SAFETY MANUAL** - Read before operation and keep in a safe place for future reference to learn proper, safe operating techniques.
25. **GUIDE BAR COVER** - Used to cover guide bar and saw chain during transport and storage. Remove guide bar cover before using unit.

SPECIFICATIONS

MODEL	PPF-2100	PPF-2110
Length	2.39 m (7 ft, 10 in.)	
Length w/Optional 3 ft. extension	3.30 m (10 ft, 10 in.)	
Width	0.22 m (8.75 in.)	
Height	0.23 m (9.0 in.)	
Weight (dry)	5.91 kg (13.0 lb.)	6.9 kg (15.2 lb.)
Engine Type	Air cooled, two-stroke, single cylinder gasoline engine	
Bore	32.2 mm (1.268 in.)	
Stroke	26.0 mm (1.04 in.)	
Displacement	21.2 cc (1.29 cu. in.)	
Exhaust System	Spark Arrestor Muffler	
Carburetor	Diaphragm, w/primer bulb	
Ignition System	CDI (capacitor discharge ignition)	
Spark Plug	NGK BPMR-7A Gap 0.65 mm (0.026 in.)	
Fuel	Mixed (Gasoline and Two-stroke Oil)	
Fuel/Oil Ratio	50:1 ECHO High Performance, two-stroke air cooled engine oil	
Gasoline	89 Octane unleaded. DO NOT use fuel containing methyl alcohol, more than 10% ethyl alcohol or 15% MTBE.	
Oil	50:1 ECHO High Performance, two-stroke air cooled engine oil	
Fuel Tank Capacity	0.4 lit. (14.0 US fl. oz.)	
Recoil Starter System	Automatic Recoil Starter	
Clutch	Centrifugal Type	
Sprocket Type	6 tooth spur, 9.53 mm (3/8 inch) pitch	
Shaft Tube Assembly	25.4mm (1") Galvanized Steel	25.4mm (1in.) Galvanized Steel w/vinyl cover
Power Transmission Shaft	6.35 mm (1/4 inch) Flex Cable	
Gear Case Ratio	1.5:1	
Oiling System	Automatic	
Chain Oil Capacity	225 ml (7.6 oz.)	
Handles	Right hand grip w/throttle trigger and throttle trigger lockout / Left foam hand grip	
Shoulder Harness	Standard	
Idle Speed (RPM)	2300 - 3000	
Wide Open Throttle Speed (RPM)	8000 - 11000	
Guide Bar and Saw Chain	254 mm (10 in.) ; 9.53 mm (3/8 inch) pitch chain	

Specifications, descriptions and illustrative material in this literature are as accurate as known at the time of publication, but are subject to change without notice. Illustrations may include optional equipment and accessories, and may not include all standard equipment.

ASSEMBLY

For your convenience the Power Pruner™ has been shipped with the power head attached and throttle linkage assembled. We recommend the power head remain attached to the drive shaft and housing at all times.

CUTTING ATTACHMENT TO DRIVE SHAFT INSTALLATION

Tools Required: 3 mm Hex Wrench

Parts Required: Power Head/Drive Shaft; Cutting Attachment

WARNING DANGER

Saw chain is sharp! Always wear gloves when handling cutting attachment, otherwise serious personal injury may result.

1. Loosen the (4) four lower bolts (A) on the cutting attachment, and remove location bolt (B).
2. Slide the cutting attachment onto the shaft housing until the hole in the neck of the cutting attachment is aligned with the hole (C) in the housing. (It may be necessary to rotate the saw chain slightly to align the internal pinion and drive shaft.)
3. Insert location bolt (B) into hole (C) and tighten to snug.
4. Tighten bolts (A), clamping the cutting attachment onto the housing.

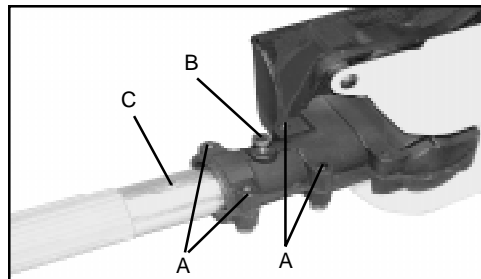

3 FOOT EXTENSION INSTALLATION

(Optional)

Tools Required: Screwdriver, 3 mm Hex Wrench

Parts Required: 914 mm (3 Foot) Extension P/N 99946400010

WARNING DANGER

Saw Chain is sharp! Always wear gloves when handling cutting attachment, otherwise serious personal injury may result.



1. Remove the cutting attachment from the Power Pruner™ shaft housing by removing the location bolt (B), loosening the (4) four lower bolts (A) clamping the cutting attachment to the shaft housing and slide the cutting attachment off.
2. Loosen the 4 screws (D) on the extension clamp and slide the extension onto the shaft housing until the hole (E) in the extension clamp lines up with the hole (C) in the shaft housing. Insert the #8 x 1/2 in. self-tapping screw (F) into hole (C) and tighten to snug.
3. Follow the steps outlined in Cutting Attachment to Drive Shaft Installation to install the cutting attachment to the extension.

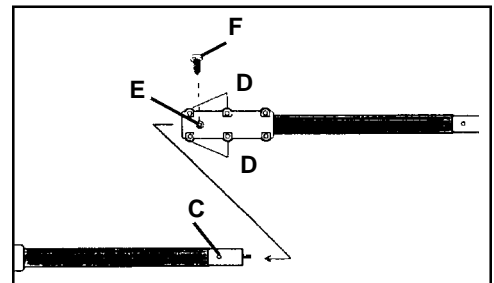
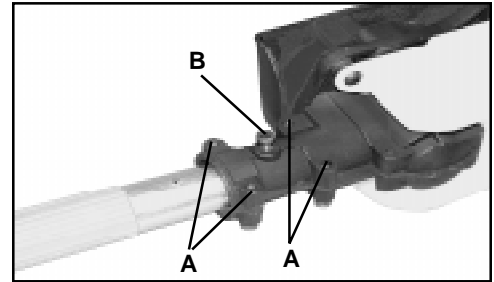

SAW CHAIN TENSION ADJUSTMENT

Tools Required: 10x19mm (13/32x3/4in.) T-wrench provided

WARNING **DANGER**

Always wear gloves when handling saw chain, otherwise serious personal injury may result.

To Adjust Saw Chain Tension.

1. Loosen two (2) 10 mm (13/32 in.) guide bar nuts (A) located on cutting attachment using the T-wrench provided.
2. Turn saw chain tensioner screw (B) (located next to guide bar in sprocket cover) clockwise to tighten saw chain on guide bar. Turning screw counter clockwise will loosen saw chain on guide bar.
3. Tighten guide bar nuts firmly. Move saw chain backwards on guide bar by hand. Saw chain should move freely on guide bar if it is in proper mesh with sprocket.

Keep the saw chain lubricated and properly adjusted and the guide bar nuts tightened firmly at all times. If saw chain is difficult to rotate or binds on guide bar, it is too tight.

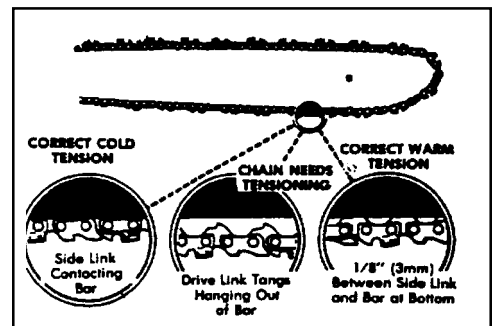
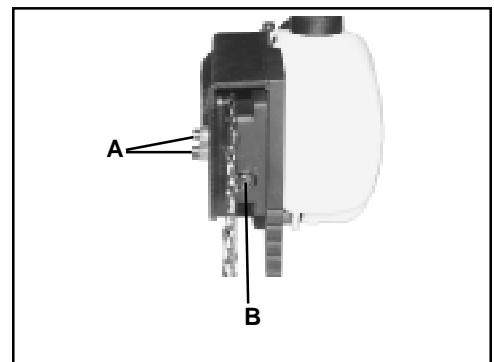

PRE-OPERATION

FUEL

Fuel Requirements

Gasoline - Use 89 Octane [$\frac{R+M}{2}$] gasoline or gasohol known to be good quality. Gasohol may contain up to 10% Ethyl (grain) alcohol or 15% MTBE (methyl tertiary-butyl ether). Gasohol containing methanol (wood alcohol) is **NOT** approved.

Two-Stroke Oil - A two-stroke engine oil meeting ISO-L-EGD Standard (ISO/CD 13738), must be used. Echo brand Premium 50:1 oil meets this standard. Engine problems due to inadequate lubrication caused by failure to use an ISO-L-EGD approved oil, such as Echo Premium 50:1 Two-stroke Oil, will void the two-stroke engine warranty. (Emission related parts **only** are covered for two years, regardless of two-stroke oil used, per the statement listed in the EPA Phase I/California Emission Defect Warranty Explanation.)

Mixing - Follow directions on the oil container.

Handling Fuel

WARNING DANGER

Fuel is **VERY** flammable. Use extreme care when mixing, storing or handling, or serious personal injury may result.

- Use an approved fuel container.
- DO NOT smoke near fuel.
- DO NOT allow flames or sparks near fuel.
- Fuel tanks/cans may be under pressure. Always loosen fuel caps slowly allowing pressure to equalize.
- NEVER refuel a unit when the engine is HOT!
- NEVER refuel a unit with the engine running.
- DO NOT fill fuel tanks indoors. ALWAYS fill fuel tanks out doors over bare ground.
- Securely tighten fuel cap after refueling.
- Inspect for fuel leakage. If fuel leakage is found, do not start or operate unit until leakage is repaired.

After Refueling;

- Wipe any spilled fuel from the unit.
- Move at least 3 M (10 ft.) from refueling location before starting the engine.

After use;

- DO NOT store a unit with fuel in its tank. Leaks can occur. Return unused fuel to an approved fuel storage container.

Storage -

Fuel storage laws vary by locality. Contact your local government for the laws affecting your area. As a precaution, store fuel in an approved, air tight container. Store in a well ventilated, unoccupied building, away from sparks and flames. Do not store fuel longer than 30 days.

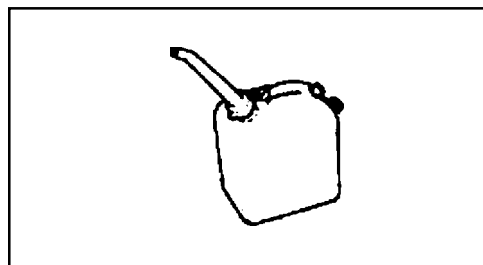
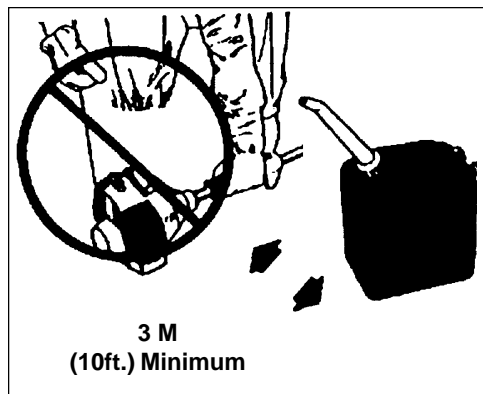
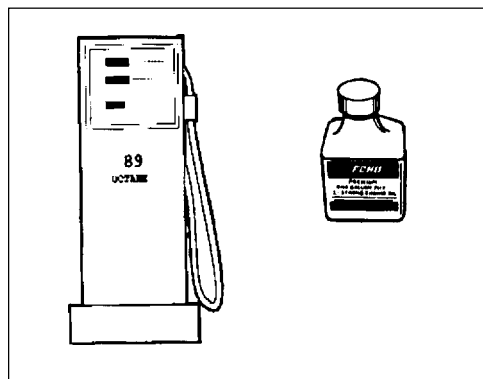

IMPORTANT

Stored fuel ages. Do not mix more fuel than you expect to use in thirty (30) days, ninety (90) days when a fuel stabilizer is added.

IMPORTANT

Stored two-stroke fuel may separate. ALWAYS shake fuel container thoroughly before each use.

S	M	T	W	T	F	S
1	2	3	4	5	6	7
8	9	10	11	12	13	14
15	16	17	18	19	20	21
22	23	24	25	26	27	28
29	30	31				

LUBRICATING THE GUIDE BAR AND SAW CHAIN

Automatic Oiling System

1. Wipe debris from around oil fill cap.
2. Remove oil fill cap and fill reservoir with a quality, low viscosity guide bar and saw chain oil.

NOTE

The discharge volume of the automatic oiler is preset to deliver 3 to 4 cc/min. at normal operating RPM. During heavy or dry cutting conditions the oil discharge volume may be adjusted to assure adequate lubrication. Refill the oil reservoir with each tank of fuel.

IMPORTANT

To prevent plastic deterioration, do not use synthetic or silicone based oil.

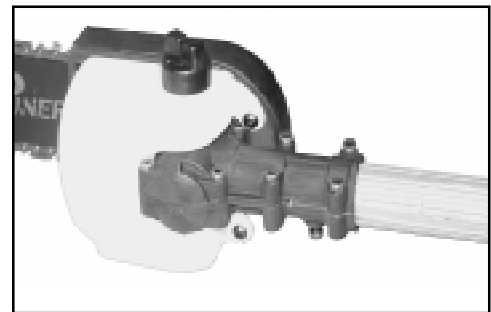

ADJUSTING AUTOMATIC OILER

Tools required: 10x19mm (13/32x3/4) T-Wrench provided

1. Remove two (2) 10 mm guide bar retaining nuts and sprocket cover.
2. From bottom of gear case, turn adjustment screw (A) clockwise to decrease oil volume - counter clockwise to increase oil volume.

NOTE

Very little visible oil on the saw chain will provide sufficient lubrication.

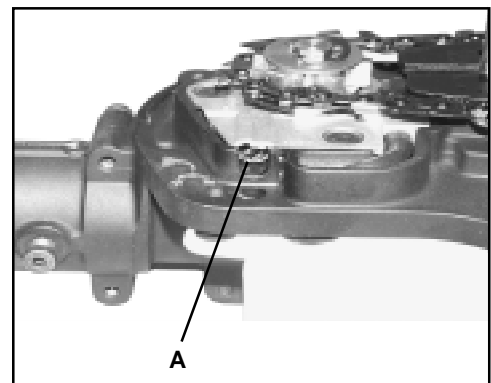

EQUIPMENT CHECK

Before operation a complete check of the unit must be performed;

- Check unit for loose/missing nuts, bolts and screws. Tighten and/or replace as needed.
- Inspect fuel lines, tank and area around carburetor for fuel leaks. DO NOT operate unit if leaks are found.
- Check that the cutting attachment is firmly attached and the saw chain is correctly tensioned on the guide bar. Dull, loose or damaged saw chain should not be used. Refer to page 29 for correct Filing Saw Chain procedure.
- Check that shoulder harness is adjusted for safe, comfortable operation. See figure at right for proper adjustment.

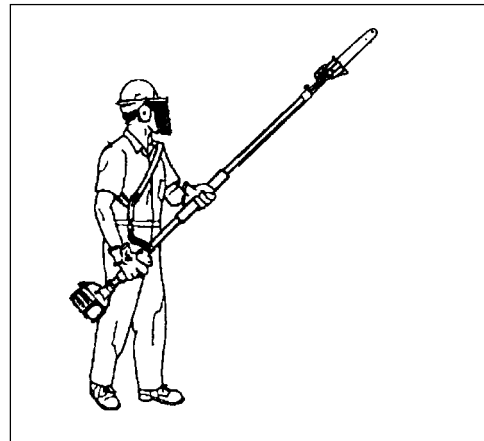
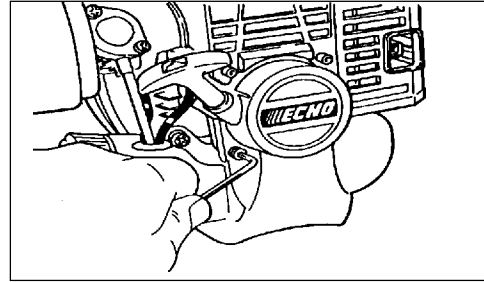

DETERMINE OPERATION AREA

- Before starting the unit, equip yourself and fellow workers in the 15 M (50 ft.) safety zone with the required protective equipment and clothing.
- Review the area to be trimmed. Look for hazards that could contribute to unsafe conditions, such as overhead electrical lines or dead branches.
- Spectators, children and animals must be prevented from coming nearer than 15 M (50 ft.) while the pruner is in use.
- Large branches should be removed in sections.

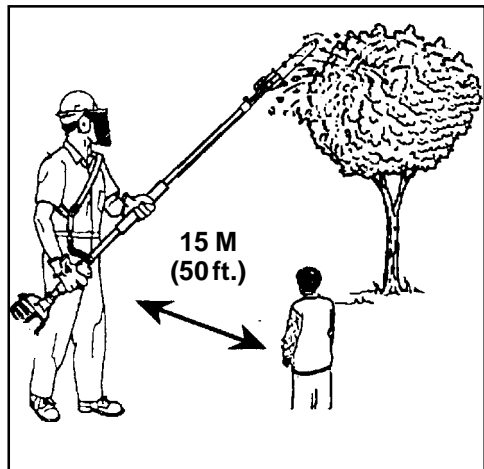

OPERATION

WARNING **DANGER**

Do not operate this product indoors or in inadequately ventilated areas. Engine exhaust contains poisonous emissions which can cause serious injury or death.

- Provide all operators of this equipment with the Operator's Manual, and instructions for safe operation.
- Before starting the unit, equip yourself and any other person working within the 15 M (50 ft.) Safety Zone with the required Protective Equipment and clothing.
- Always evaluate the area being cut for overhead hazards, such as dead branches which may fall and strike the operator or helpers.
- Be aware of branches bouncing when striking the ground.
- Larger branches should be removed in sections.
- During operation, the complete unit, especially the shaft tube and bearing housing may become very hot, too hot to touch. Avoid contact during and immediately after operation.

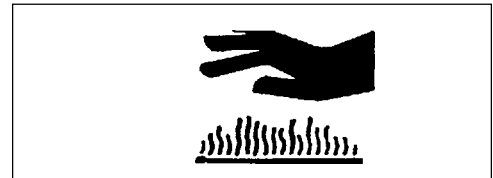
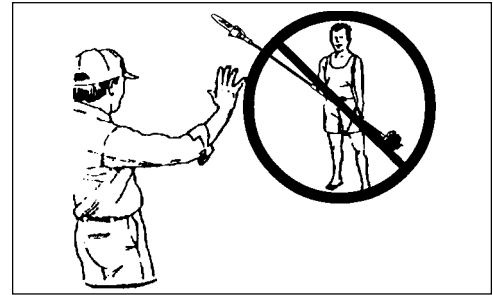

STARTING COLD ENGINE

WARNING **DANGER**

The cutting attachment should not move at idle. If cutting attachment moves, readjust carburetor according to "Carburetor Adjustment" instructions in this manual or see your ECHO Dealer, otherwise serious personal injury may result.

1. Stop Switch - Start/Run.
Move stop switch button (A) forward away from the STOP position.
2. Choke - Cold Start.
Move choke (B) to "Cold Start" Position.
3. Primer Bulb -Purge.
Pump primer bulb (C) 10 times. Fuel will be visible and flow freely in the clear fuel tank return line.

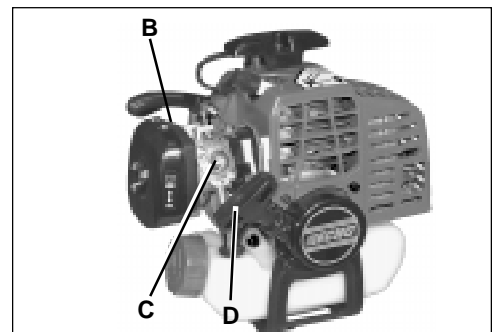
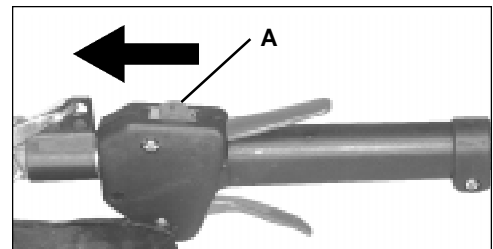

WARNING **DANGER**

Inspect starting area for hazards such as rocks, glass, debris etc. which could be contacted by the cutting attachment when starting. Keep helpers and bystanders at least 15 M (50 ft.) from starting area, otherwise serious personal injury may result.

4. Lay the pruner on a flat clear area. Firmly grasp right hand grip and throttle trigger lockout with left hand and fully depress throttle trigger to wide open position. Rapidly pull recoil starter handle/rope (D) until engine fires (or maximum five [5] pulls).

5. After engine fires (or five [5] pulls), move choke lever back to "Run" position. Hold throttle trigger and throttle trigger lockout fully depressed and pull recoil starter handle/rope until engine starts and runs. Release throttle trigger and allow unit to warm up at idle for several minutes.

NOTE

If engine does not start with choke in "Run" position after 5 pulls, repeat instructions.

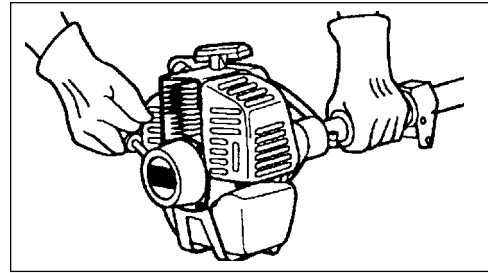

6. After engine warm up, gradually depress throttle trigger to increase engine RPM to operating speed.

STARTING WARM ENGINE

WARNING  **DANGER**

The cutting attachment should not move at idle. If cutting attachment moves, readjust carburetor according to "Carburetor Adjustment" instructions in this manual or see your ECHO Dealer, otherwise serious personal injury may result.

1. Stop Switch - Start/Run. Move Stop Switch button (A) forward away from the STOP position.
2. Start - Pull Rope. Lay the pruner on a flat clear area and pull the recoil starter handle (D) until the engine fires.

NOTE

If engine does not start after 5 pulls, use Cold Start Procedure.

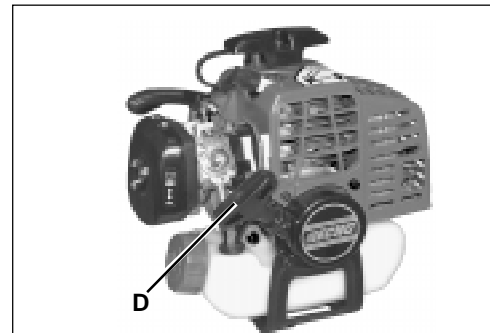
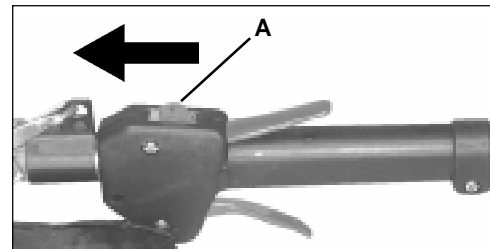

STOPPING ENGINE

1. Release Throttle. Allow engine to idle for a minute.
2. Stop Switch - Stop. Move stop switch button (A) backward to STOP position.

WARNING  **DANGER**

If engine does not stop when stop switch is moved to STOP position, close choke - COLD START position - to stall engine. Have your ECHO dealer repair stop switch before using pruner again.

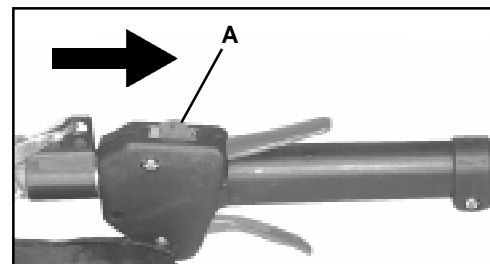

PRUNING TECHNIQUES

The Power Pruner™ is designed for light to medium trimming of limbs and branches up to 203mm (8 in.) in diameter. Follow these tips for successful operation.

- Plan cut carefully. Check direction branch will fall.
- Plan retreat path from falling branch. Cut branches bounce when striking ground.
- Long branches should be removed in several pieces.
- Do not stand directly beneath branch being cut.
- When ready to cut:
Hold "cutting shoe" against branch. This will prevent whipping of the branch. DO NOT use back and forth sawing action.
- Look out for branch immediately behind the branch being cut. If saw chain hits rear branch damage to saw chain and guide bar may occur.
- Accelerate to full throttle.
- Apply cutting pressure.
- Ease cutting pressure when nearing end of cut to maintain control.
- When pruning a limb 102 mm (4 in.) diameter or larger cut as follows:
 1. Under cut 1/4 limb diameter near tree trunk.
 2. Finish top cut slightly farther out on limb.
 3. Flush cut stub at trunk.
- DO NOT use for felling or bucking.

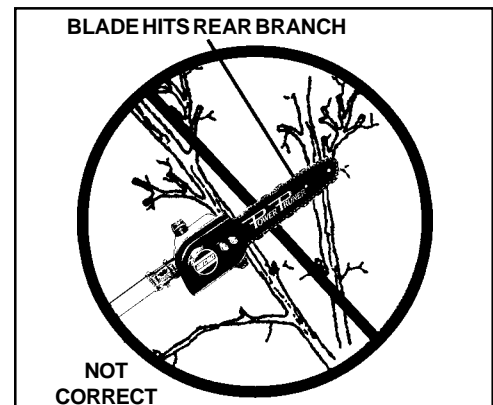
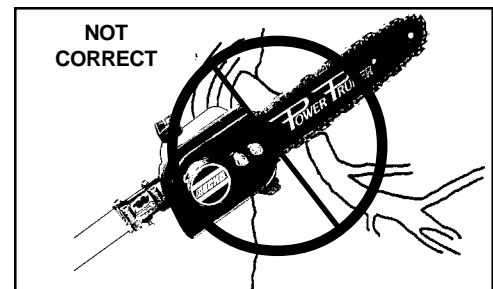
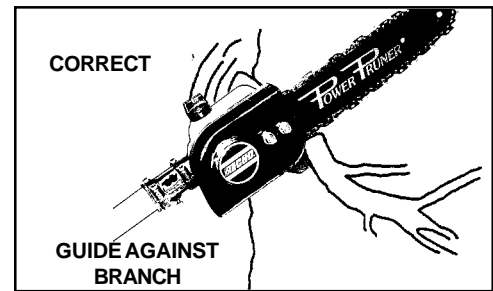

MAINTENANCE

Your ECHO Power Pruner™ is designed to provide many hours of trouble free service. Regular scheduled maintenance will help your pruner achieve that goal. If you are unsure or are not equipped with the necessary tools, you may want to take your unit to an ECHO Service Dealer for maintenance. To help you decide whether you want to DO-IT-YOURSELF or have the ECHO Dealer do it, each maintenance task has been graded. If the task is not listed, see your ECHO Service Dealer for repairs.

SKILL LEVEL

- Level 1** = Easy to do. Most required tools come with unit.
- Level 2** = Moderate difficulty. Some specialized tools may be required.
- Level 3** = Experience required. Specialized tools are required.

ECHO offers **REPOWER™** Maintenance Kits and Parts to make your maintenance job easier. Just below each task heading are listed the various part numbers required for that task. See your ECHO dealer for these parts.

MAINTENANCE INTERVALS

COMPONENT/ SYSTEM	MAINTENANCE PROCEDURE	REQ'D SKILL LEVEL	DAILY OR BEFORE USE	EVERY REFUEL	3 MONTHS OR 90 HOURS	6 MONTHS OR 270 HOURS	YEARLY 600 HOURS
Recommended Echo Dealer Maintenance Procedures							
Cylinder Exhaust Port	Inspect/Clean/Decarbon	3			I / C		
Do-It-Yourself Maintenance Procedures							
Air Filter	Inspect/Clean/Replace	1	I / C		I*		
Choke System	Inspect/Clean	2	I / C				
Fuel Filter	Inspect/Replace	1			I		I / R *
Fuel System, leaks	Inspect/Replace	1	I / R *	I	I		
Cooling System	Inspect/Clean	2	I / C				
Muffler Spark Arrestor	Inspect/Replace	2			I / R *		
Power Transmission Shaft	Inspect/Clean/Oil	2	I (1)				I
Guide Bar	Inspect/Clean/Lubricate	2	I / C	I			
Saw Chain	Inspect/Sharpen/Replace/ Lubricate	2	I / R*	I			
Recoil Starter Rope	Inspect/Clean	1	I / R*				
Spark Plug	Inspect/Clean	2			I / C	R *	
Screws/Nuts/Bolts	Inspect/Tighten/Replace	1	I / R *				

MAINTENANCE PROCEDURE LETTER CODES: I = INSPECT, R = REPLACE, C = CLEAN

IMPORTANT NOTE - Time intervals shown are maximum. Actual use and your experience will determine the frequency of required maintenance.

MAINTENANCE PROCEDURE NOTES:

* All recommendations to replace are based on the finding of damage or wear during inspection.

(1) Apply ECHO® LUBE™ every 25 hours of use.

AIR FILTER

Level 1.

Tools Required: 25mm or 50mm (1 in. or 2 in.) medium bristle paint brush

Parts required: . 90008REPOWER™ AIR & FUEL FILTER KIT.

1. Close choke (Cold Start Position). This prevents dirt from entering the carburetor throat when the air filter is removed. Brush accumulated dirt from the air cleaner area.
2. Remove the air cleaner cover. Clean and inspect the element for damage. If element is fuel soaked and very dirty, replace.
3. If element can be cleaned and reused, be certain it:
 - properly fits the cavity in the air cleaner cover.
 - is installed with the original side out.

NOTE

Carburetor adjustment may be needed after air filter cleaning/ replacement. See Carburetor Adjustment Section.

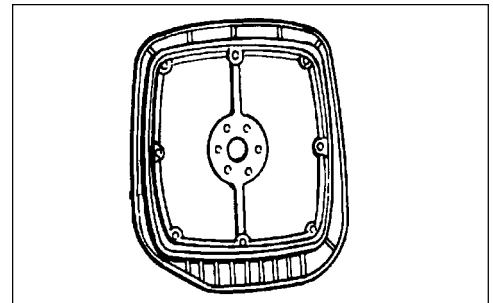
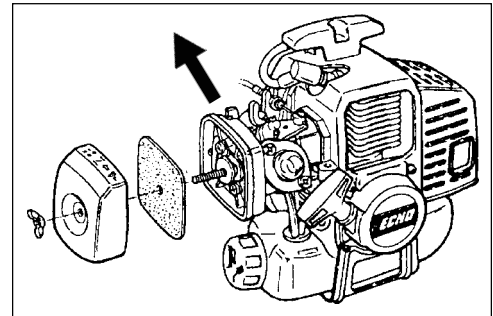
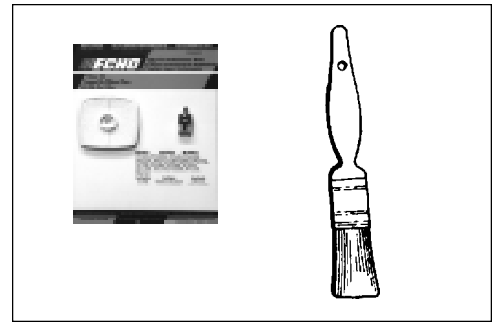

FUEL FILTER

Level 1.

Tools Required: 203-254 mm (8-10in.) length of wire with one end bent into a hook. Clean rag, funnel, and an approved fuel container

Parts Required: 90008REPOWER™ AIR & FUEL FILTER KIT.

WARNING DANGER

Fuel is **VERY** flammable. Use extreme care when mixing, storing or handling or serious personal injury may result.

1. Use a clean rag to remove loose dirt from around fuel cap and empty fuel tank.
2. Use the “fuel line hook” to pull the fuel line and filter from the tank.
3. Remove the filter from the line and install the new filter.

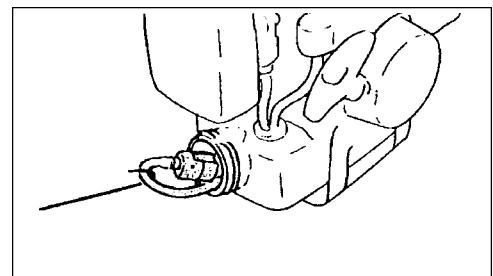
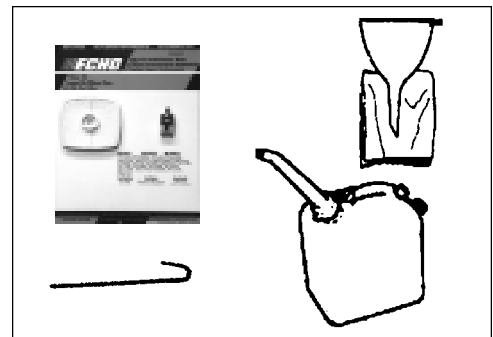

SPARK PLUG

Level 2.

Tools Required: 10x19mm (13/32x3/4in.) T-wrench, Feeler gauge, (preferably a wire gauge), Soft metal brush

Parts Required: Spark Plug, NGK BPMR-7A; P/N 15901010230

1. Remove spark plug and check for fouling, worn and rounded center electrode.
2. Clean the plug or replace with a new one. DO NOT sand blast to clean. Remaining sand will damage engine.
3. Adjust spark plug gap by bending outer electrode.
4. Tighten spark plug to 145-155 kg/cm (125-135 in. lb.).

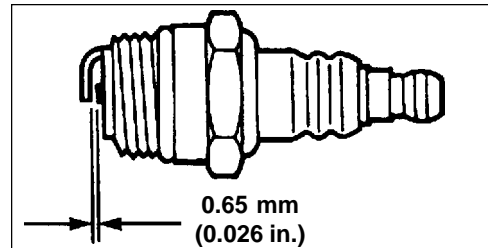
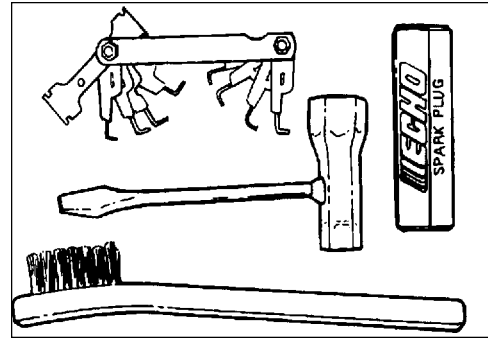

COOLING SYSTEM CLEANING

Level 3.

Tools Required: Screwdriver, 3 mm and 4 mm Hex wrench, Pointed Wood Stick, 25mm or 50mm (1 in. or 2 in.) medium bristle paint brush

Parts Required: None.

IMPORTANT

To maintain proper engine operating temperatures, cooling air must pass freely through the cylinder fin area. This flow of air carries combustion heat away from the engine.

Overheating and engine seizure can occur when:

- Air intakes are blocked, preventing cooling air from reaching the cylinder.
- Dust and grass build up on the outside of the cylinder. This build up insulates the engine and prevents the heat from leaving.

Removal of cooling passage blockages or cleaning of cooling fins is considered "Normal Maintenance". Any failure attributed to lack of maintenance is not warranted.

1. Remove spark plug lead from spark plug and throttle linkage end from the carburetor swivel.
2. Remove the four screws that retain the engine cover (A). Two at the top of the recoil starter, two on either side of the front. Lift the cover from the engine and lay to the front of the Power Pruner™.

NOTE

The throttle linkage remains assembled to the engine cover and the spark plug lead and grommet remain installed.

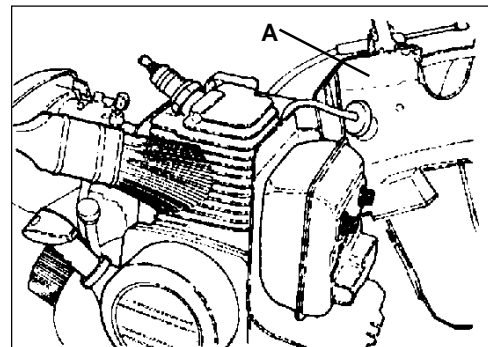
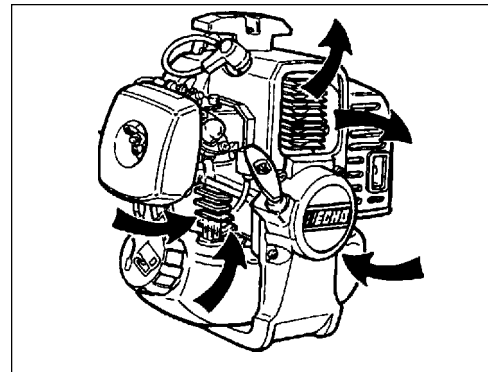
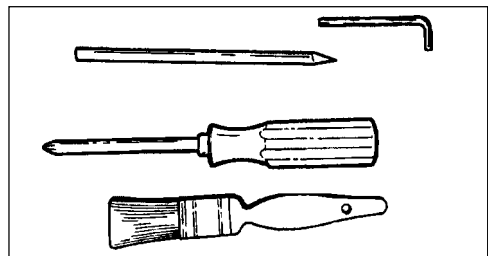

3. Use the wooden stick or brush to remove dirt from cylinder fins.
4. Remove grass and leaves from the grid between the recoil starter and fuel tank.
5. Assemble components in reverse order.

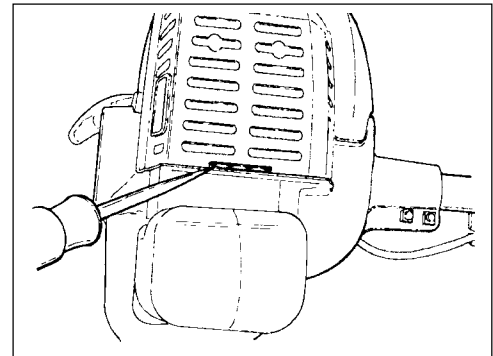
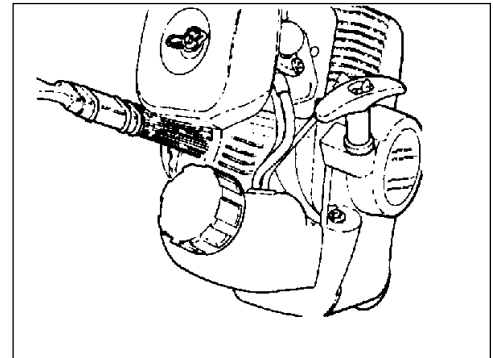

NOTE

When installing the engine cover, be certain the tab of the metal deflector shield is in the slot of the engine cover.

EXHAUST SYSTEM

Spark Arrestor Screen

Level 2.

Tools Required: Screwdriver, Soft metal brush

Parts Required: Screen P/N 14586240630, Gasket Lid P/N 14586642031

1. Remove engine cover (A). See “Cleaning Cooling System” pages 24 & 25 for step by step instructions.
2. Place piston at Top Dead Center (TDC) to prevent carbon/dirt from entering cylinder.
3. Remove spark arrestor screen cover (B), screen holder (C), gasket (D) and screen (E) from muffler body.
4. Clean carbon deposits from screen and muffler components.
5. Replace screen if it is cracked, plugged or has holes burned through.
6. Assemble components in reverse order.

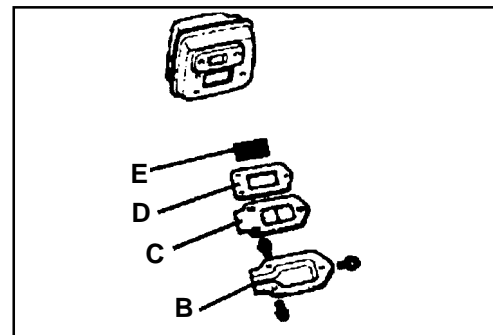
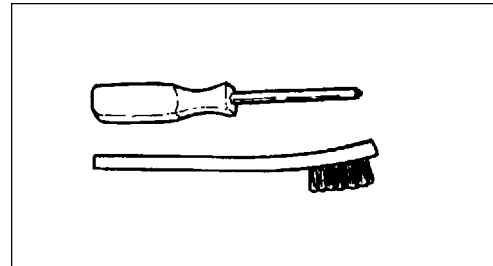

NOTE

When installing the engine cover, be certain the tab of the metal deflector shield is in the slot of the cover.

CARBURETOR ADJUSTMENT

Emission Models

Level 2.

Tools Required: Screwdriver with 2mm blade width, Tachometer (ECHOP/N99051130017)

Parts required: None.

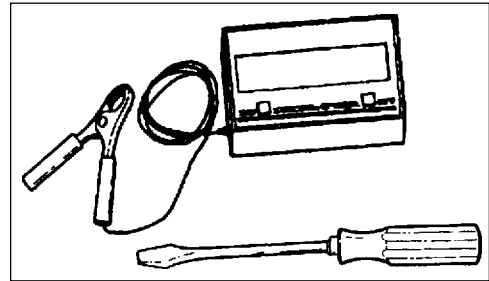

NOTE

Every unit is run at the factory and the carburetor is set in compliance with EPA Phase 1 and California Emission Regulations. In addition, the carburetor is equipped with HI (A) and LO (B) needle adjustment limiters that prevent settings outside acceptable limits.

1. Before adjusting the carburetor, clean or replace the air filter and spark arrester screen.
2. Start engine and run for several minutes to reach operating temperature.
3. Stop engine. Turn HI (A) speed needle CCW (counter clockwise) to stop. Turn LO (B) speed needle midway between full CCW and CW (clockwise) stops.
4. Idle Speed Adjustment.
-Start engine and turn idle (C) speed adjustment screw CW until the cutting attachment begins to turn, then turn the screw CCW until cutting attachment stops turning. Turn screw CCW an additional 1/4 turn.
5. Accelerate to full throttle for 2-3 seconds to clear excess fuel from engine then return to idle. Accelerate to full throttle to check for smooth transition from idle to full throttle. If engine hesitates, turn LO (B) needle CCW an additional 1/8 turn and repeat acceleration. Continue adjusting until smooth acceleration results.
6. Check HI speed RPM at W.O.T. (Wide Open Throttle). HI speed RPM should be set to specifications found on page 13 "Specifications" of this manual.
7. Check idle speed and reset if necessary. If a tachometer is available, idle speed should be set to the specification found on page 13 "Specifications" of this manual.

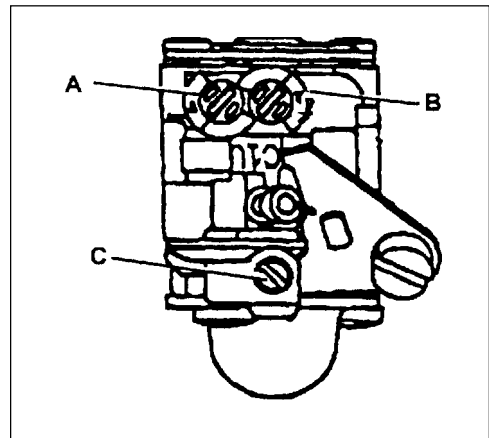

WARNING DANGER

When carburetor adjustment is completed, saw chain should not move at idle, otherwise serious personal injury may result.

CARBURETOR ADJUSTMENT

Non Emissions Models

Level 2

Tools Required: Screwdriver with 2mm blade width, Tachometer (ECHOP/N99051130017)

Parts required: None.

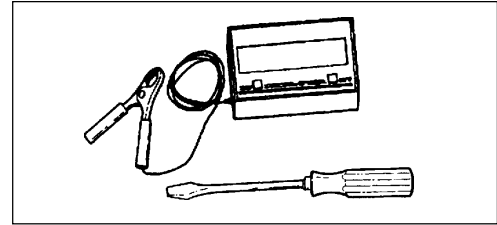

NOTE

If carburetor has limiter caps follow "Carburetor Adjustment" procedures for Emission models on previous page.

Idle Speed Adjustment

Turn "idle" speed adjustment screw (C) CW (clockwise) until cutting attachment begins to turn, then turn screw out CCW (counter clockwise) until cutting attachment stops turning. Turn screw out, CCW an additional 1/4 turn.

WARNING DANGER

Saw chain must not turn when unit is idling, otherwise serious personal injury may result.

Basic Setting

1. Stop engine and turn both LO (B) and HI (A) needles in, CW until they stop and are lightly seated.

IMPORTANT

DO NOT over tighten needles. Forcing them to tighten will damage the carburetor.

2. Turn needles out CCW: LO (B) 3/4 turns; HI (A) 1-3/4 turns.

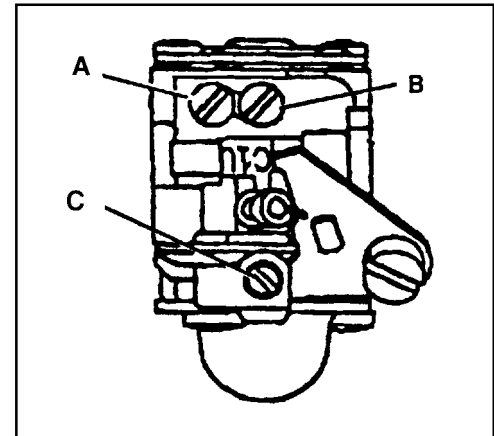

Fine Tuning (Requires Accurate Tachometer)

1. Start engine and allow to warm to operating temperature (minimum 2 - 3 minutes) while varying engine speed from idle to full throttle.
2. Always begin fine tuning with LO (B) needle.
 - a. Lean drop-off - With engine idling, turn LO (B) needle slowly CW (in) to lean drop-off point. RPM will increase, then abruptly drop-off. Note this position. (1)
 - b. Rich drop-off - With engine idling, slowly turn LO (B) needle CCW (out) to rich drop-off point. RPM will increase then gradually slow and drop-off. Note this position. (2)
 - c. Final setting - Set needle at mid point between lean rich drop-off points. (3)
 - d. Turn needle 1/8 turn CCW (out) making mixture slightly richer. (4)
3. HI speed adjustment.
Adjust HI (A) needle with tachometer. Refer to Wide Open Throttle RPM settings listed in "Specifications" on page 13.
4. Check idle speed and reset if necessary. If tachometer is available, idle speed should be set to the specifications found on page 13 "Specifications" of this manual.

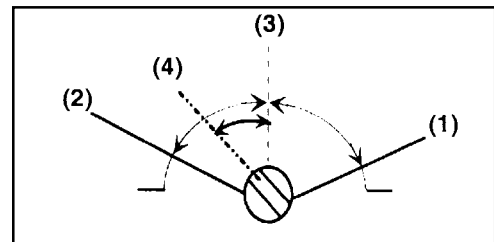

WARNING DANGER

When carburetor adjustment is completed, saw chain should not move at idle, otherwise serious personal injury may result.

GUIDE BAR AND SAW CHAIN REPLACEMENT

WARNING DANGER

Never try to replace or adjust guide bar and saw chain with engine running. This saw chain is VERY sharp, wear heavy gloves to protect your hands when handling it. Wear eye protection meeting CE or ANSI specification Z87.1.

Guide Bar Replacement / Installation

Level 3

Tools Required: 10x19mm (13/32x3/4 in.) T-Wrench

- Remove two (2) 10 mm (13/32 in.) guide bar nuts (A) and relieve saw chain tension turning screw (B) counter clockwise.
- Remove sprocket cover.
- Free saw chain from sprocket and remove from guide bar. If guide bar is okay proceed to saw chain installation.
- Slide guide bar forward and remove from cutting attachment. Install new guide bar sliding it onto the cutting attachment as far as possible.
- Turn saw chain adjustment screw until adjusting pin (C) fits into round hole in guide bar.

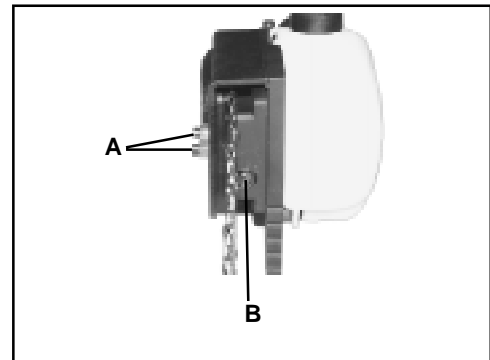

Saw Chain Installation

Level 3

- Install new saw chain onto guide bar. Make sure cutting links are faced towards the nose of the guide bar.
- Engage saw chain with sprocket.
- Secure sprocket cover with (2) two guide bar nuts.
- Follow instruction for adjusting saw chain tension page 15.

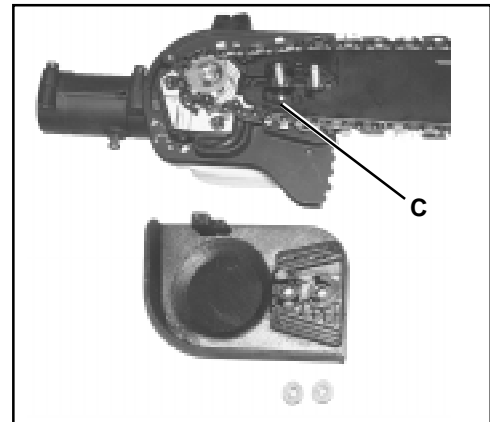

FILING SAW CHAIN

Level 3.

Tools Required: 4.5 mm round File P/N 89751001130; Flat File P/N 89751100230; Depth Gauge P/N 89751400232.

IMPORTANT

Dull or damaged cutters will result in poor cutting performance, increased vibration and premature saw chain failure.

WARNING DANGER

Always stop engine and wear gloves when filing saw chain, otherwise serious personal injury may result.

1. Set round file (A) in cutter at 30° angle. One fifth (1/5) of the file should be exposed above top cutter edge.
2. Keep file horizontal in cutter and file in one direction.
3. File until cutter top and side bevel edges are sharp without nicks.
4. Place depth gauge tool (B) firmly on top of cutter with .025" slot and end against front cutter raker. File cutter raker with flat file until flush with top of depth gauge.
5. Finish cutter sharpening by rounding front raker edge (C) with flat file.

6. Properly filed cutter is as shown.
7. Apply clean oil and rotate saw chain slowly to wash away filings.
8. If saw chain is coated or clogged with resin, clean in kerosene then soak in oil.

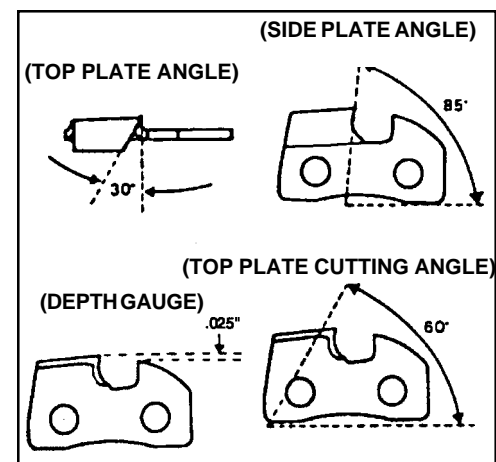
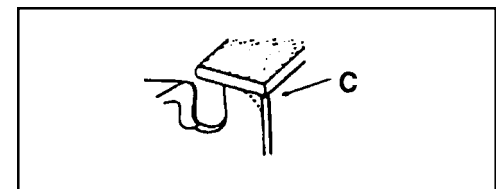
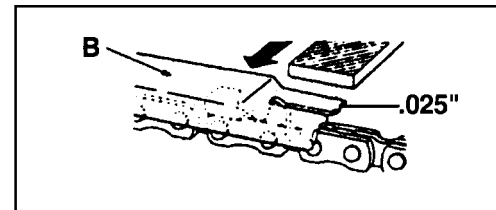
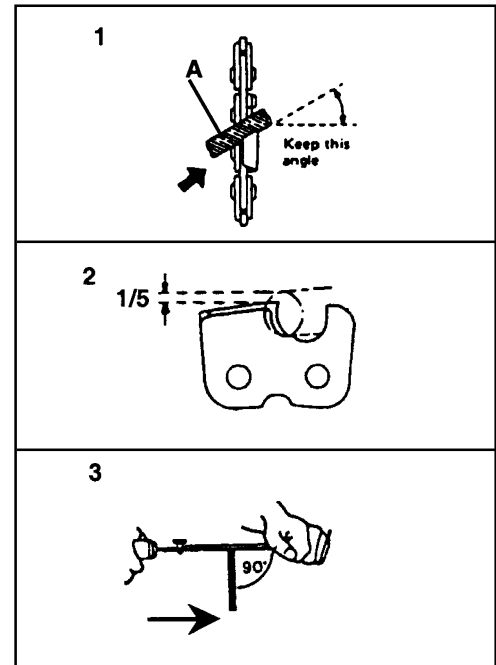

TROUBLESHOOTING

Problem		Cause	Remedy
Engine — starts hard — does not start			
Engine Cranks	Fuel at carburetor ↓ No fuel at carburetor	Fuel strainer clogged Fuel line clogged Carburetor	Clean Clean See your Echo dealer
	Fuel at cylinder ↓ No fuel at cylinder	Carburetor	See your Echo dealer
	Muffler wet with fuel	Fuel mixture is too rich	Open choke Clean/replace air filter Adjust carburetor See your Echo dealer
	Spark at end of plug wire ↓ No spark at end of plug wire	Stop switch off Electrical problem Interlock switch	Turn switch on See your Echo dealer See your Echo dealer
	Spark at plug ↓ No spark at plug	Spark gap incorrect Covered with carbon Fouled with fuel Spark plug defective	Adjust. 0.65 mm (0.026 in.) Clean or replace Clean or replace Replace plug
Engine does not crank		Internal engine problem	See your Echo dealer
Engine runs	Dies or Accelerates poorly	Air filter dirty Fuel filter dirty Fuel vent plugged Spark plug Carburetor Cooling system plugged Exhaust port/spark arrestor screen plugged	Clean or replace Replace Replace Clean and adjust/replace Adjust Clean Clean

STORAGE

Long Term Storage (over 30 days)

Do not store your unit for a prolonged period of time (30 days or longer) without performing protective storage maintenance which includes the following:

1. Store unit in a dry, dust free place, out of the reach of children.

WARNING  **DANGER**

Do not store in enclosure where fuel fumes may accumulate or reach an open flame or spark or serious personal injury may result.

2. Place the stop switch (A) in the "OFF" position.
3. Remove accumulation of grease, oil, dirt and debris from exterior of unit.
4. Perform all periodic lubrication and services that are required.
5. Tighten all the screws and nuts.
6. **Drain** the fuel tank **completely** and pull the recoil starter handle several times to remove fuel from the carburetor.
7. Remove the spark plug and pour 7 cc (1/4 oz.) [1/2 tablespoon] of fresh, clean, two-stroke engine oil into the cylinder through the spark plug hole.
 - A. Place a clean cloth over the spark plug hole.
 - B. Pull the recoil starter handle 2-3 times to distribute the oil inside the engine.
 - C. Observe the piston location through the spark plug hole. Pull the recoil starter handle slowly until the piston reaches the top of its travel and leave it there.
8. Install the spark plug (do not connect spark plug cable).
9. Install the guide bar cover on the guide bar and saw chain during storage.

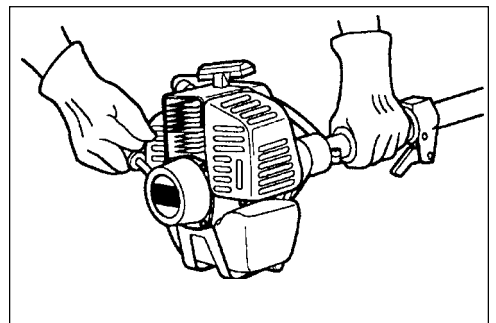
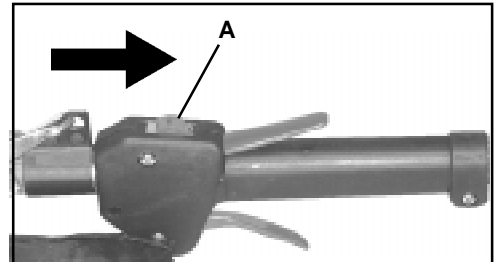

SERVICING INFORMATION

PARTS

Genuine ECHO Parts and ECHO REPOWER™ Parts and Assemblies for your ECHO products are available only from an Authorized ECHO Dealer. When you do need to buy parts **always** have the Model Number, Type number and Serial Number of the unit with you. You can find all three numbers on the engine housing. For future reference, write them in the space provided below.

Model No. _____ Type No. _____ SN. _____

SERVICE

Service of this product during the warranty period must be performed by an Authorized ECHO Service Dealer. For the name and address of the Authorized ECHO Service Dealer nearest you, ask your retailer or call: 1-800-432-ECHO (3246). When presenting your unit for Warranty service/repairs, proof of purchase is required.

ECHO CONSUMER PRODUCT SUPPORT

If you require assistance or have questions concerning the application, operation or maintenance of this product you may call the ECHO Consumer Product Support Department at 1-800-673-1558 from 8:00 am to 5:00 pm (Central Standard Time) Monday through Friday. Before calling, please know the model and serial number of your unit to help your Consumer Product Support Representative.

WARRANTY CARD

This card is our means of registering all original owners of ECHO equipment. The card plus proof of purchase provides you the assurance that authorized warranty work will be done. It also provides a direct link between you and ECHO if we find it necessary to contact you.

ADDITIONAL OR REPLACEMENT MANUALS

Safety Manuals P/N X752000000 are available, free of charge, from your ECHO dealer or by contacting Echo Incorporated, 400 Oakwood Road, Lake Zurich, IL 60047.

Operator's and Parts Manuals are available for purchase from your ECHO dealer or directly from ECHO. [See ordering instructions below.]

ORDERING INSTRUCTIONS

To obtain a Parts Catalog or Operator's Manual send a check or money order for \$2.00 per Parts Catalog or \$1.50 per Operator's Manual made payable to ECHO, INCORPORATED. State on a sheet of paper the model number and serial number of the ECHO unit you have, part number of the manual (if known), your name and address and mail to address above.

Available Parts Catalog

PPF-2100 Type 1/1E S/N 506100 & Up 99922203001
PPF-2110 Type 1/1E S/N 501890 & Up 99922203001

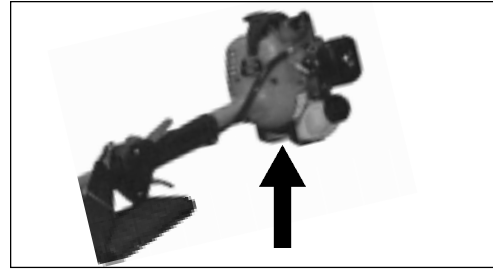

DEALER?

Call
1-800-432-ECHO

CONSUMER PRODUCT SUPPORT

1-800-673-1558
8 - 5 Mon - Fri C.S.T.

ECHO LIMITED WARRANTY REGISTRATION CARD / CARTE D'ENREGISTREMENT DE GARANTIE LIMITEE		
<small>Range of limited warranty protection included with Purchase & Manual / Scope of l'assurance de garantie limitée inclue dans le manuel d'utilisation</small>		
Please Print / Ecrire en caractères d'impression		
Purchase & Name / Date de l'achat et du nom		A. Primary use of tool / Usage principal de l'outil 1. () Professional/Amateur / Professionnel/Particulier 2. () Homeowner / Particulier
Address / Adresse		
City / Ville		B. Safety / Précautions importantes relatives with product / Informations de sécurité Précautions importantes avec le produit 1. () Operator's Manual / Manuel d'Utilisateur 2. () Safety Glasses / Lunettes de sécurité 3. () Safety Manual / Manuel de sécurité
Purchase Model / No. de caractéristique		
Store Name Where Purchased / Nom de l'établissement d'achat		TO PURCHASE A COPY OF THE ECHO SAFETY VIDEO OVERVIEW CONTACT: POUR L'ACHETER S'IL VOUS EN FAUT LA VIDEO DES PRESSIONS DE SECURITE ECHO - CONTACTER ECHO, INCORPORATED ATTN: VIDEO DEPT. 400 OAKWOOD RD. LAKE ZURICH, IL 60047 U.S.A. OWNERS COPY/COPIE DU PROPRIETAIRE 8941241010
Model Number / Numéro de modèle		
Local Number / Numéro de magasin		Registering your purchase enables us to contact you in the unlikely event of a service update or product recall and verify your ownership in the event of theft or loss. / Enregistrer votre achat nous permet de vous contacter dans le cas improbable de modifications des instructions d'utilisation ou en regard de produit et de vérifier que vous êtes le propriétaire en cas de vol ou de perte.
Type No. / No. de type		
Customer Signature / Signature de client		
<small>(Include Signature of Applicant) (Signature de candidat/acheteur de matériel)</small>		

ECHO Incorporated
400 Oakwood Road
Lake Zurich, IL 60047
Technical Publications Orders

ECHO®

ECHO, INCORPORATED

400 OAKWOOD ROAD
LAKE ZURICH, IL 60047

Free Manuals Download Website

<http://myh66.com>

<http://usermanuals.us>

<http://www.somanuals.com>

<http://www.4manuals.cc>

<http://www.manual-lib.com>

<http://www.404manual.com>

<http://www.luxmanual.com>

<http://aubethermostatmanual.com>

Golf course search by state

<http://golfingnear.com>

Email search by domain

<http://emailbydomain.com>

Auto manuals search

<http://auto.somanuals.com>

TV manuals search

<http://tv.somanuals.com>