



# ProThatch Attachment

## *Operator's Manual*

**Model**                      **99944200563**

**MODELS USED ON:**        **SRM-260SB/261SB**  
                                      **PAS-2400**  
                                      **PAS 230/231**  
                                      **PAS 260/261**  
                                      **PAS-265**



### **WARNING**

Read rules for safe operation and instructions carefully. ECHO provides an Operator's Manual with your original Pro Attachment Series power source or Split Boom Trimmer. That manual and this manual must be read and understood for proper and safe operation. Failure to do so can result in serious injury.

**X7702093501**

**X770001301**  
**03/09**

## INTRODUCTION

Welcome to the ECHO family. This ECHO product was designed and manufactured to provide long life and on-the-job-dependability. Read and understand this manual included with your attachment. You will find this manual easy to use and full of helpful operations tips and SAFETY messages.

## THE OPERATOR'S MANUAL

contains specifications and information for operation, starting, stopping, maintenance, storage and assembly specific to this product.



## TABLE OF CONTENTS

Introduction.....	2	Operation.....	12
- The Operator's Manual .....	2	Maintenance.....	13
Safety .....	3	- Skill Levels .....	13
- Manual Safety Symbols & Important Information.....	3	- Maintenance Intervals.....	13
- International Symbols.....	3	- Lubrication.....	13
- Personal Condition and Safety Equipment.....	4	- Tine Replacement .....	14
- Equipment.....	6	Storage .....	16
Description.....	7	Specifications .....	16
Contents .....	8	Servicing Information .....	20
Assembly.....	8	- Parts/Serial Number .....	20
- Fender/Wheel Assembly to		- Service .....	20
Lower Shaft Assembly.....	8	- ECHO Customer Assistance .....	20
- Lower Drive Shaft Assembly to		- Warranty Card.....	20
Dethatcher Assembly .....	8	- Additional or Replacement Manuals .....	20
- Front J-Handle Assembly .....	9		
- Power Head Shaft to Lower Shaft Assembly .....	10		
- Fender/Wheel Assembly Adjustment .....	10		
- Front J-Handle Adjustment.....	11		

Specifications, descriptions and illustrative material in this literature are as accurate as known at the time of publication, but are subject to change without notice. Illustrations may include optional equipment and accessories, and may not include all standard equipment.

**SAFETY**

**MANUAL SAFETY SYMBOLS AND IMPORTANT INFORMATION**

Throughout this manual and on the product itself, you will find safety alerts and helpful, information messages preceded by symbols or key words. The following is an explanation of those symbols and key words and what they mean to you.

**⚠ DANGER**

The safety alert symbol accompanied by the word “DANGER” calls attention to an act or condition which **WILL** lead to serious personal injury or death if not avoided.

**⚠ WARNING**

The safety alert symbol accompanied by the word “WARNING” calls attention to an act or condition which **CAN** lead to serious personal injury or death if not avoided.

**⚠ CAUTION**

The safety alert symbol accompanied by the word “CAUTION” calls attention to an act or condition which may lead to minor or moderate personal injury if not avoided.



**CIRCLE AND SLASH SYMBOL**

This symbol means the specific action shown is prohibited. Ignoring these prohibitions can result in serious or fatal injury.

**NOTE**

This enclosed message provides tips for use, care and maintenance of the unit.

**IMPORTANT**

The enclosed message provides information necessary for the protection of the unit.

**INTERNATIONAL SYMBOLS**

Symbol form/shape	Symbol description/application	Symbol form/shape	Symbol description/application
	Read and understand Operator's Manual.		Fuel and oil mixture
	Wear eyes, ears and head protection		Hot Surface
	Emergency stop		DO NOT smoke near fuel.
	Wear hand protection. Use two handed.		DO NOT allow flames or sparks near fuel.
	Wear slip resistant foot wear.		Safety/Alert

Symbol form/shape	Symbol description/application	Symbol form/shape	Symbol description/application
	Keep feet away from rotating attachment		Thrown objects
	Engine choke control.		Primer bulb
	Carburetor adjustment - Low speed mixture		Ignition ON/OFF
	Carburetor adjustment - Idle speed		Carburetor adjustment - High speed mixture
	Keep bystanders and helpers away 15 m (50 ft.).		

## PERSONAL CONDITION AND SAFETY EQUIPMENT



### **WARNING**

ProThatch users risk injury to themselves and others if the ProThatch attachment is used improperly and or safety precautions are not followed. Proper clothing and safety gear must be worn when operating the ProThatch attachment. Failure to do so can result in serious injury.

### ***Physical Condition***

Your judgment and physical dexterity may not be good:

- if you are sick,
- if you are taking medication,
- if you have taken alcohol or drugs.

Operate unit only if you are physically and mentally well.

### ***Eye Protection***

Wear eye protection that meets ANSI Z87.1 or CE requirements whenever you operate the unit.

### ***Hand Protection***

Wear no-slip, heavy duty work gloves to improve your grip on the handles. Gloves also reduce the transmission of machine vibration to your hands.

### ***Hearing Protection***

ECHO recommends wearing hearing protection whenever unit is used.

### ***Proper Clothing***

Wear snug fitting, durable clothing;

- Pants should have long legs, shirts with long sleeves.
- Wear hair covering to contain long hair.
- DO NOT WEAR SHORTS,
- DO NOT WEAR TIES, SCARFS, JEWELRY.

Wear sturdy work shoes with non-skid soles;

- DO NOT WEAR OPEN TOED SHOES,
- DO NOT OPERATE UNIT BAREFOOTED.

Keep long hair away from engine and air intake. Retain hair with cap or net.

### ***Hot Humid Weather***

Heavy protective clothing can increase operator fatigue which may lead to heat stroke. Schedule heavy work for early morning or late afternoon hours when temperatures are cooler.

### ***Vibration and Cold --***

It is believed that a condition called Raynaud's Phenomenon, which affects the fingers of certain individuals may be brought about by exposure to vibration and cold. Exposure to vibration and cold may cause tingling and burning sensations followed by loss of color and numbness in the fingers. The following precautions are strongly recommended because the minimum exposure which might trigger the ailment is unknown.

- Keep your body warm, especially the head, neck, feet, ankles, hands and wrists.
- Maintain good blood circulation by performing vigorous arm exercises during frequent work breaks and also by not smoking.
- Limit the hours of operation. Try to fill each day with jobs where operating the unit or other hand-held power equipment is not required.
- If you experience discomfort, redness, and swelling of the fingers followed by whitening and loss of feeling, consult your physician before further exposing yourself to cold and vibration.



***Repetitive Stress Injuries --***

It is believed that overusing the muscles and tendons of the fingers, hands, arms, and shoulders may cause soreness, swelling, numbness, weakness, and extreme pain in those areas. Certain repetitive hand activities may put you at a high risk for developing a Repetitive Stress Injury (RSI). An extreme RSI condition is Carpal Tunnel Syndrome (CTS), which could occur when your wrist swells and squeezes a vital nerve that runs through the area. Some believe that prolonged exposure to vibration may contribute to CTS. CTS can cause severe pain for months or even years.

To reduce the risk of RSI/CTS, do the following:

- Avoid using your wrist in a bent, extended or twisted position. Instead try to maintain a straight wrist position. Also, when grasping, use your whole hand, not just the thumb and index finger.
- Take periodic breaks to minimize repetition and rest your hands.
- Reduce the speed and force in which you do the repetitive movement.
- Do exercises to strengthen the hand and arm muscles.
- See a doctor if you feel tingling, numbness or pain in the fingers, hands, wrists or arms. The sooner RSI/CTS is diagnosed, the more likely permanent nerve and muscle damage can be prevented.

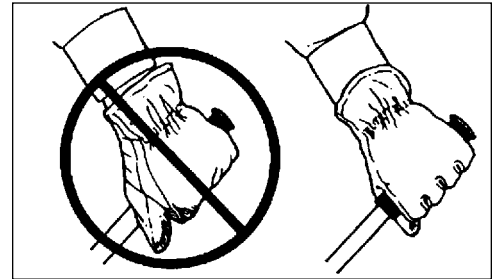

**DANGER**

Do not operate this product indoors or in inadequately ventilated areas. Engine exhaust contains poisonous emissions and can cause serious injury or death.

**Read the Manuals**

- Provide all users of this equipment with the Operator's Manual and Safety Manual for instructions on Safe Operation.

**Clear the Work Area**

- Spectators and fellow workers must be warned, and children and animals prevented from coming nearer than 15 m (50 ft.) while the unit is in use.

**Keep a Firm Grip**

- Hold the front and rear handles with both hands, with thumbs and fingers tightly encircling the handles.

**Keep a Solid Stance**

- Maintain footing and balance at all times. Do not stand on slippery, uneven or unstable surfaces. Do not work in odd positions or on ladders. Do not over reach.

**Avoid Hot Surfaces**

- During operation, the drive shaft housing, attachment bearing housing and muffler cover area may become very hot, too hot to touch. Avoid contact during and immediately after operation.

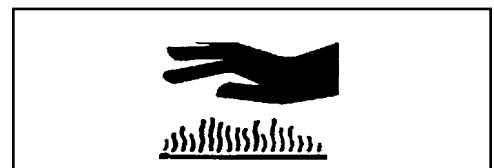

## EQUIPMENT



### WARNING

Use this attachment with ECHO approved models only. Serious injury may result from the use of this attachment combined with a non approved ECHO product.

Before operation a complete check of the unit must be performed;

- ECHO, INC. will not be responsible for the failure of dethatching devices, accessories and parts which have not been tested and approved by ECHO for use with this ProThatch Attachment.
- Check unit for loose/missing nuts, bolts and screws. Tighten and/or replace as needed.
- Inspect ProThatch tines for damage and that they are firmly secured in place. Replace tines if damaged or missing.
- Check that the dethatcher attachment is firmly attached and in safe operating condition.

### *Parts*

- Do not use dethatcher attachment if any part is missing or damaged.
- Have repairs done only by an authorized ECHO Service Dealer.
- Do not use any accessory or replacement part unless it is recommended in this Operator's Manual.



### WARNING

Moving parts can amputate fingers or cause severe injuries. Keep hands, clothing and loose objects away from all openings.

- **ALWAYS** stop engine, disconnect spark plug, and make sure all moving parts have come to a complete stop before removing obstructions, clearing debris, or servicing unit.
- **DO NOT** start or operate unit unless all guards and protective covers are properly assembled to unit.
- **NEVER** reach into any opening while the engine is running. Moving parts may not be visible through openings.

## DESCRIPTION

Locate this safety decal on your attachment. Make sure the decal is legible and that you understand and follow the instructions on it. If it cannot be read, a new one can be ordered from your ECHO dealer. See PARTS ORDERING instructions for specific information.

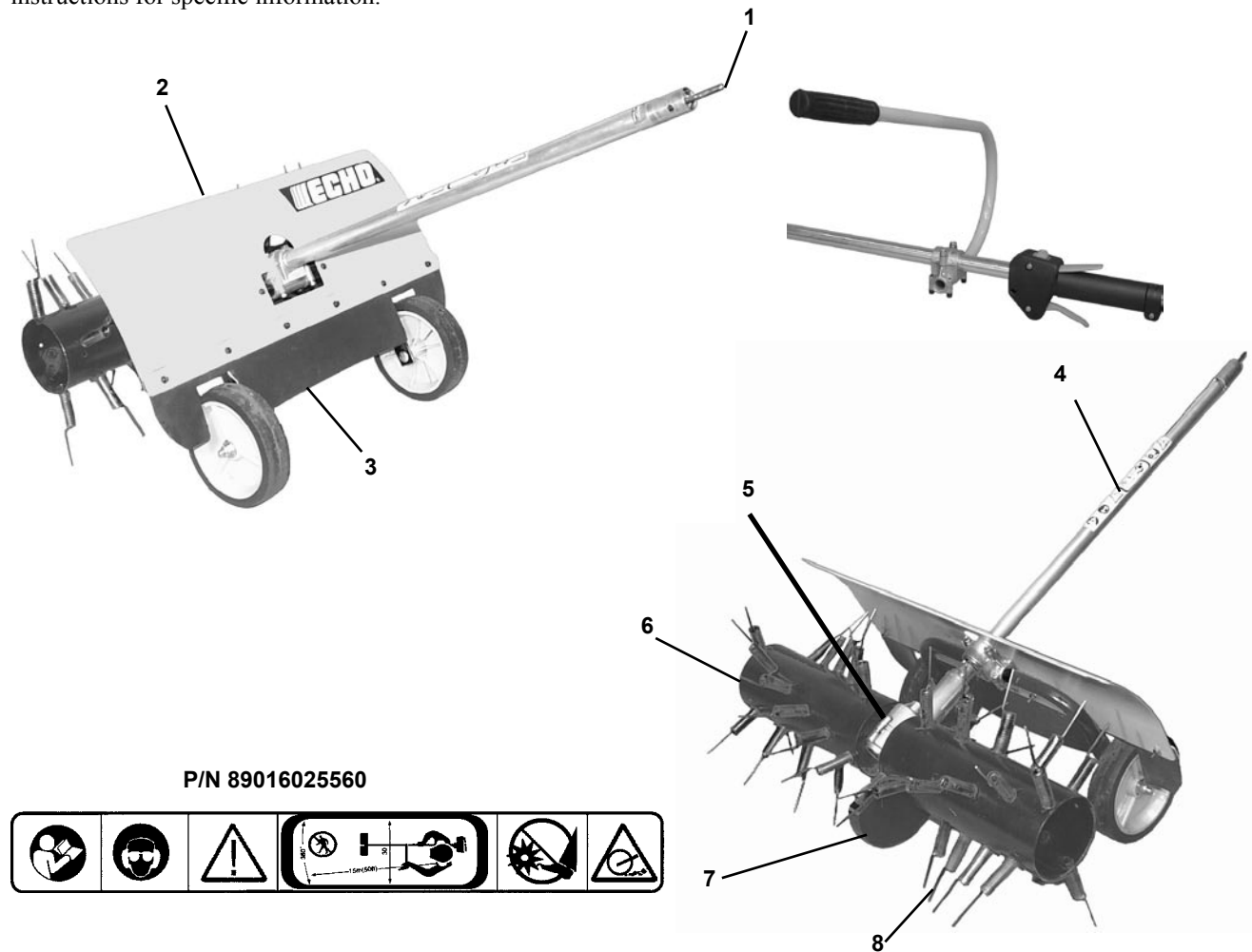

1. **FLEXIBLE DRIVE CABLE** - Cable end fits into drive shaft coupler of Pro Attachment Series or Split Boom models. Lubricate drive cable every 25 hours with high temperature automotive grease.
2. **FENDER / WHEEL ASSEMBLY** - Consists of pre-assembled wheels, wheel bracket, fender and rubber flap. For best results, wheels should be adjusted for 13 mm (0.5 in.) ground clearance and are intended to provide operational stability over uneven ground.
3. **FENDER / RUBBER FLAP** - Provides operator protection against thrown thatch, rocks and other debris. Always insure that fender and flap are in place and in good condition before operating Pro Thatch Attachment.
4. **LOWER DRIVE SHAFT ASSEMBLY** - Included separately in the carton and must be assembled to the dethatcher / gear housing assembly. Contains flexible drive cable, outer shaft housing and safety decal.
5. **DETHATCHER / GEAR HOUSING ASSEMBLY** - Right and left reels pre-assembled to gear housing.
6. **DETHATCHER REELS** - Dethatcher reels have 22 tines each and are pre-assembled to the gear housing. Reels must be installed properly to prevent side pull.
7. **GRASS GUIDE** - Attached to the dethatcher assembly / gear housing. The guide prevents tines from penetrating too deeply into the ground, which can cause the dethatcher to bounce and give uneven thatch removal.
8. **TINES** - Steel springs with 51 mm (2 in.) fingers. Tines are protected by a plastic cover to prevent thatch and dirt buildup.

## CONTENTS

After opening the carton, check for damage. Immediately notify your retailer or ECHO Dealer of damaged or missing parts. Use the contents list to check for missing parts.

- \_\_\_ 1 - ProThatch Attachment
- \_\_\_ 1 - Dethatcher / Gear Housing Assembly
- \_\_\_ 1 - Lower Drive Shaft Assembly
- \_\_\_ 1 - Fender / Wheel Assembly
- \_\_\_ 1 - J-Handle
- \_\_\_ 1 - Operators Manual
- \_\_\_ 1 - Warranty Registration Card



## ASSEMBLY

### FENDER / WHEEL ASSEMBLY TO LOWER DRIVE SHAFT ASSEMBLY

**Tools Required:** 10 mm Open End Wrench

**Parts Required:** Lower Drive Shaft Assembly, Fender / Wheel Assembly

1. Remove vinyl cap from lower end of drive shaft tube.
2. Loosen two (2) fender/wheel assembly bracket bolts (A) with 10 mm open end wrench. The bolts should be very loose to prevent bracket from damaging locating arrow decal label.
3. Install fender/wheel assembly, fender side first, onto end of lower drive shaft without serial number label. End of drive shaft should be 95 mm (3.74 in.) from fender clamp. Assure locating hole (B) is facing upward, and locating arrow decal (C) is aligned with edge of fender clamp.
4. Tighten bolts (A).

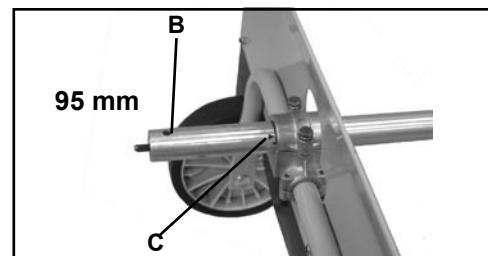
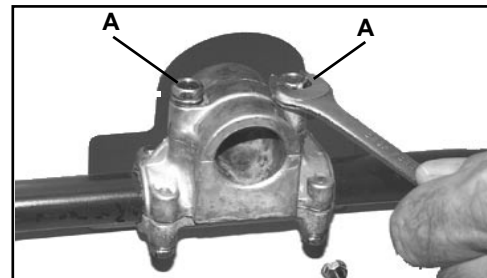

### LOWER DRIVE SHAFT ASSEMBLY TO DETHATCHER GEAR HOUSING

**Tools Required:** 4 & 5mm Hex Wrench

**Parts Required:** Dethatcher Gear Housing, Lower Drive Shaft with Fender / Wheel Assembly

1. Place dethatcher gear housing on a flat surface with gear housing shaft mount at 45° angle.
2. Remove gear housing shaft alignment screw (A) with 4 mm hex wrench.
3. Loosen gear housing shaft mounting bolt (B) with 5 mm hex wrench.

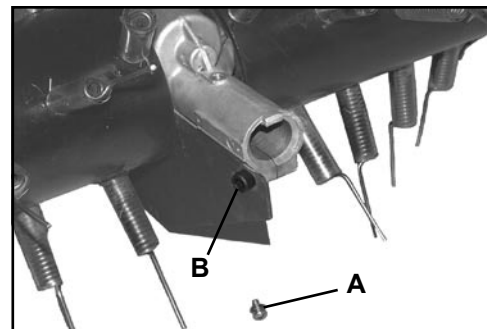



4. Install and seat lower drive shaft end (end with fender/wheel assembly) into gear housing shaft mount. Make sure grass guide (D) is facing down toward the ground.
  
5. Rotate and align hole in drive shaft housing with gear housing shaft hole. Install and tighten alignment screw (A) with 4 mm hex wrench.
  
6. Tighten gear housing shaft mounting bolt (B) with 5 mm hex wrench.
  
7. Check for proper inner flex cable (C) engagement into gear housing adaptor. If flex cable extends out of drive shaft then cable is not properly engaged. Rotate and push cable end until lower cable end slides into place in gear housing adaptor. Cable end will recess approximately 16 mm (5/8 in.) into drive shaft.

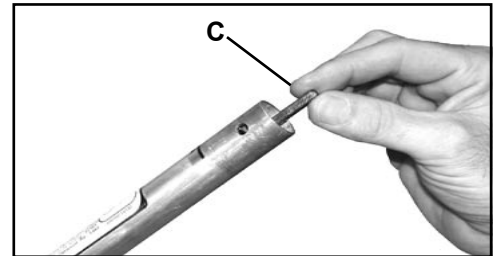
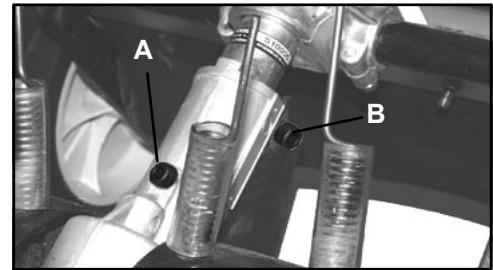
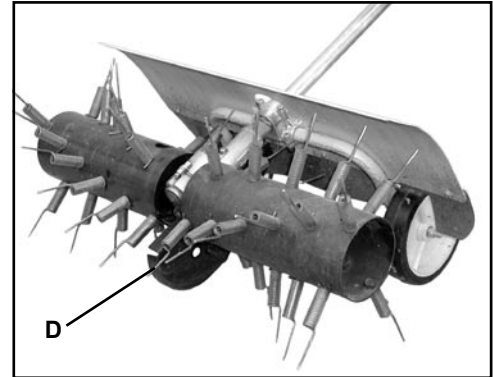

## FRONT J-HANDLE ASSEMBLY

*Tools Required:* 10 mm Open End Wrench

*Parts Required:* Pro Attachment Series or Split Boom Upper Shaft and Power Head

1. Remove original front handle assembly. Assemble handle parts with fasteners and store in a safe place for future application with other attachments.
  
2. Remove two (2) J-Handle bracket bolts (A) with 10 mm wrench.
  
3. Install J-Handle assembly with handle grip on the left side (viewed from the operator's position) onto the upper drive shaft. Lightly snug bolts (A) to temporarily hold handle in place.

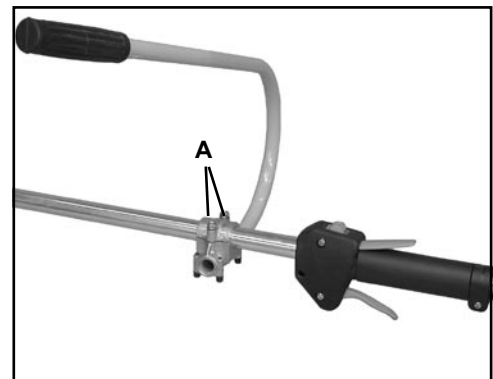
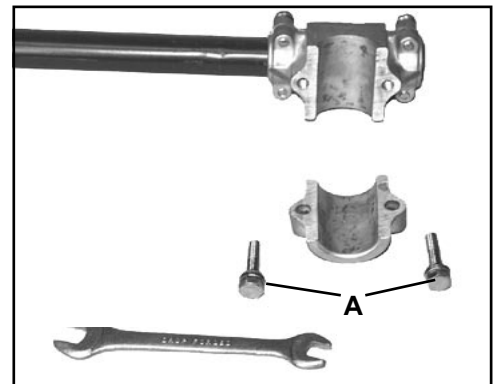

## POWER HEAD SHAFT TO LOWER SHAFT ASSEMBLY

*Tools Required:* None

*Parts Required:* PAS or SRM-SB Power Head w/Shaft & Coupling.

1. Set Power Head/Shaft Assembly on a level surface.
2. Pull locator pin (A) out, and turn counter-clockwise 1/4 turn to lock-out position.
3. Remove vinyl cap from attachment drive shaft.
4. Carefully fit attachment drive shaft assembly into coupler (B) to decal assembly line (C), making sure that the inner lower drive shaft engages into the square upper drive shaft socket.

### NOTE

Earlier model Power Heads may have shorter couplings. Short couplings fit flush to decal point (E). New couplings are 4-3/4 in. long, and fit flush to line (C).

5. Rotate locator pin (A) 1/4 turn clockwise to engage lower shaft hole. Insure locator pin is fully engaged by twisting lower drive shaft. Locator pin should snap flush in coupler. Full engagement will prevent further shaft rotation.
6. Secure lower shaft assembly to coupler by tightening clamping knob (D).

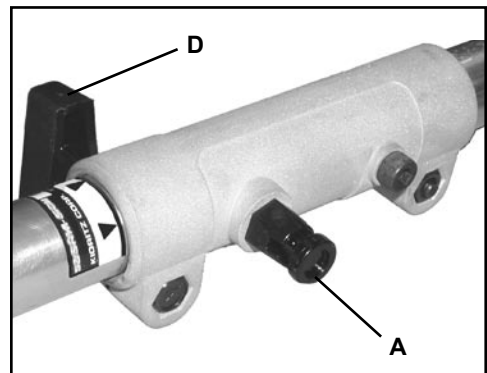
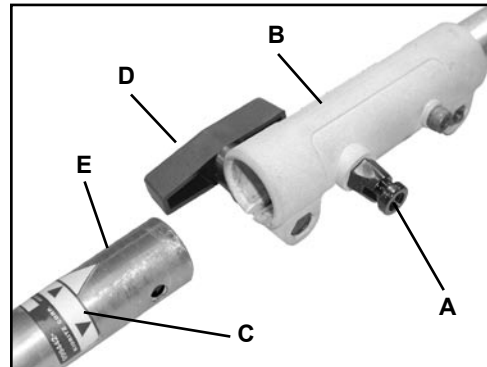

## FENDER/WHEEL ASSEMBLY ADJUSTMENT

Dethatcher combing efficiency is best when the full weight of the dethatcher assembly rests on the tines during operation. Wheel height should be adjusted for 6 - 13 mm (0.25 - 0.50 in.) above ground for operational stability over uneven grass. Perform wheel height adjustment procedures as follows:

1. Loosen (2) two lower hex head wheel bracket bolts (B) with 4 mm hex wrench.
2. Hold unit in comfortable operating position on a flat surface and check for wheel to ground clearance of 6 - 13 mm (0.25 - 0.50 in.).
3. Rotate wheels towards tines to reduce ground clearance; away from tines to increase ground clearance. Tighten bolts (B).

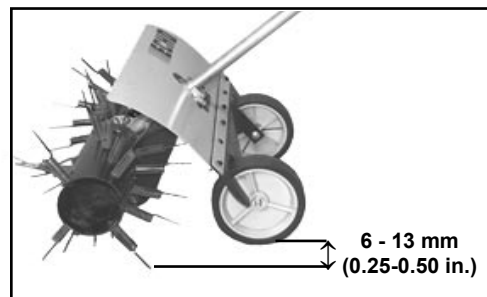
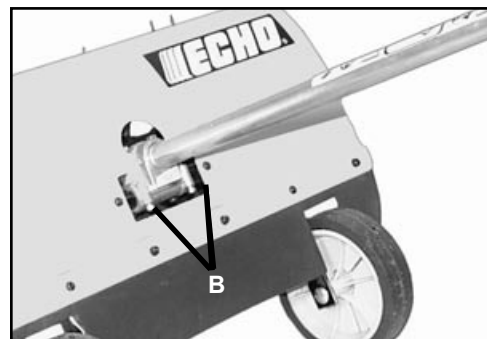

**IMPORTANT**

Do not rotate wheels against tines. Wheels and tines will be damaged during operation.

If wheel rotation is not sufficient to provide proper wheel height clearance then perform these additional steps:

4. Loosen two upper wheel bracket bolts (C) with 10 mm wrench.
5. Slide fender/wheel assembly up drive shaft housing until proper wheel clearance is achieved. Tighten hex head bolts (C).

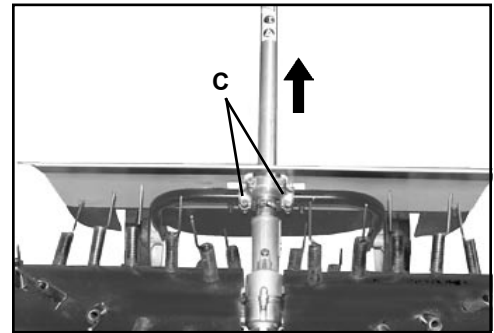

**FRONT J-HANDLE ADJUSTMENT**

*Tools Required:* 10 mm Open End Wrench

*Parts Required:* None

1. Loosen two (2) J-Handle bracket bolts (A) with 10 mm wrench.
2. Rest dethatcher tines on flat surface. Stand to left side of drive shaft housing with right hand on throttle grip and left hand on J-Handle.
3. Move J-Handle up or down drive shaft housing for comfortable operating position. Tighten J-Handle bracket bolts (A).

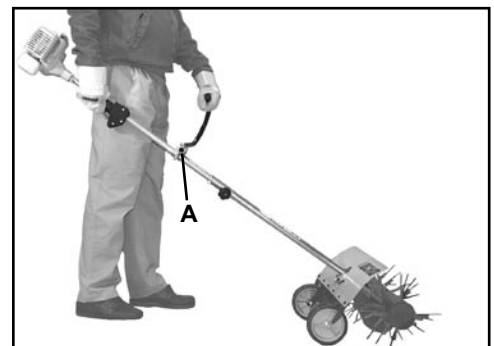
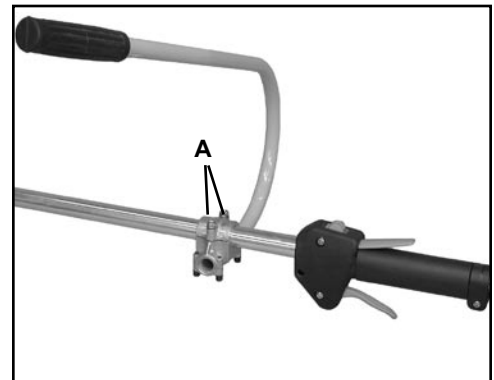

## OPERATION



### WARNING

Moving parts can amputate fingers or cause severe injuries. Keep hands, clothing and loose objects away from all openings. Always stop engine, disconnect spark plug, and make sure all moving parts have come to a complete stop before removing obstructions, clearing debris, or servicing unit.

### NOTE

- Refer to your Pro Attachment Series or Split Boom Operator's Manuals for correct engine fueling, starting and stopping instructions.

### *Dethatching Information*

Thatch is a normal buildup of grass and leaf clippings around the base of grass stems. Excessive thatch prevents air, water and nutrients from reaching the root system, increasing the probability of lawn disease from mold spore and insects. When excessive thatch is removed, air, water, nutrients and pesticides are allowed to keep your lawn healthy, promoting denser, greener grass. In most areas some thatch approximately 6-13 mm (0.25 - 0.50 in.) is healthy for soil water retention. Never remove all thatch from your lawn. Contact your local government agriculture agency for best dethatching practice for your lawn type and area.

Dethatching is recommended in early spring and late summer to allow grass to fill in low density areas of your lawn. Dethatching should also be performed at regular intervals throughout spring and summer.

Dethatching is not recommended for grasses that have above ground root systems such as St. Augustine, Floratam, Persley, or Zoysia varieties. The dethatcher tines will damage delicate interconnected root systems of these grass varieties.

### *Dethatching Operation*

1. Operate dethatcher in straight rows changing direction from row to row as shown. If thatch is very dense a second dethatching operation may be required, and should be performed 90° to the original pattern to assure best results.
2. Hold unit in a comfortable position engage throttle trigger to full and allow dethatcher tines to "pull forward" over the ground. For heavy thatch removal gently pull back against dethatching rotation, to allow the tines to fully penetrate and remove thatch.

### IMPORTANT

Do not remove grass guide attached to the gear housing to achieve deeper tine engagement. The guide prevents tines from penetrating too deeply into the ground which can cause the dethatcher to bounce during operation, and cause uneven thatch removal.

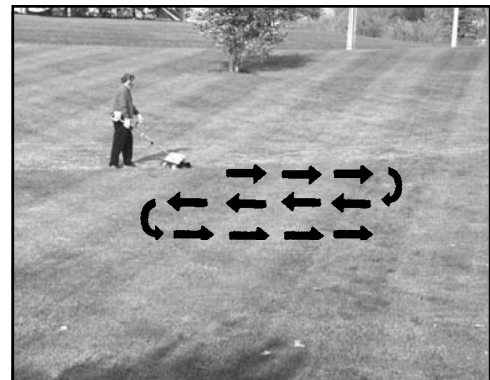

## MAINTENANCE

### **WARNING**

Moving parts can amputate fingers or cause severe injuries. Keep hands, clothing and loose objects away from all openings. Always stop engine, disconnect spark plug, and make sure all moving parts have come to a complete stop before removing obstructions, clearing debris, or servicing unit. Allow unit to cool before performing service. Wear gloves to protect hands from sharp edges and hot surfaces.

Your ECHO attachment is designed to provide many hours of trouble free service. Regular scheduled maintenance will help your attachment achieve that goal. If you are unsure or are not equipped with the necessary tools, you may want to take your unit to an ECHO Service Dealer for maintenance. To help you decide whether you want to DO-IT-YOUR-SELF or have the ECHO Dealer do it, each maintenance task has been graded. If the task is not listed see your ECHO dealer for repairs.

### SKILL LEVEL

**Level 1** = Easy to do. Most required tools come with unit.

**Level 2** = Moderate difficulty. Some specialized tools may be required.

### MAINTENANCE INTERVALS

Component/System	Maintenance Procedure	Skill Level	Frequency
Drive Shaft	Grease	1	Every 25 hours of use
Gear Housing	Grease	1	Every 25 hours of use
Tines	Inspect/Tighten/Replace	1	Before each use
Screws/Nuts/Bolts	Inspect/Tighten/Replace	1	Before each use

### LUBRICATION

#### Level 1.

*Tools Required:* 13 mm Open End Wrench, Clean Rag

*Parts Required:* EP "0" OR "00" Grease.

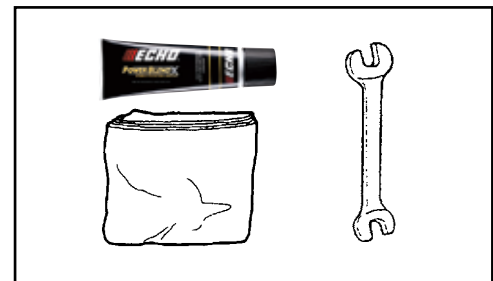

#### *Gear Housing*

1. Clean all loose debris from gear housing.
2. Remove screw plug (A) and check level of grease.
3. Add grease if necessary, DO NOT over fill.
4. Install screw plug (A).

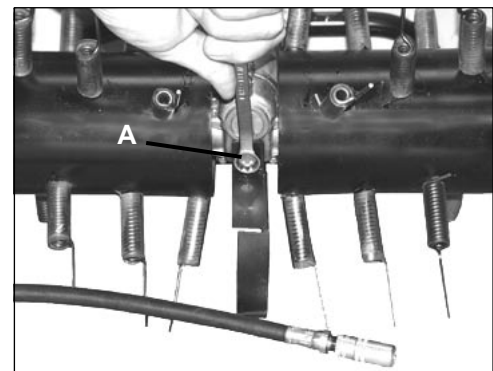

## Drive Shaft (Lower)

### IMPORTANT

Lower and upper drive shaft must be lubricated with ECHO® LUBE™ grease every 25 hours of operation, otherwise drive shaft assembly overheating and failure can result.

1. Remove gear housing locator screw (A).
2. Loosen gear housing mounting bolt (B).
3. Pull gear box from drive shaft housing.
4. Pull flexible cable from the drive shaft housing, wipe clean and re-coat with a thin coating [15 ml (1/2 oz.)] of grease
5. Slide the flexible cable back in the drive housing. DO NOT get dirt on the flex cable.
6. Position lower drive shaft (end without safety decal) into gear housing shaft mount.
7. Align hole in drive shaft housing with gear housing shaft hole (C) and seat lower drive shaft end into gear housing shaft mount. Install and tighten locator screw (A).
8. Tighten gear housing mounting bolt (B).

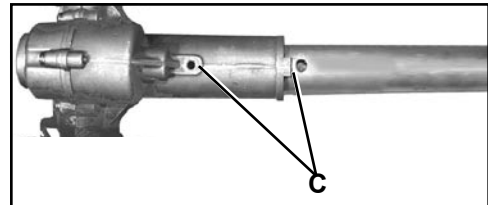
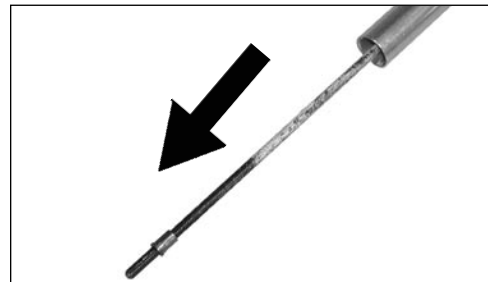
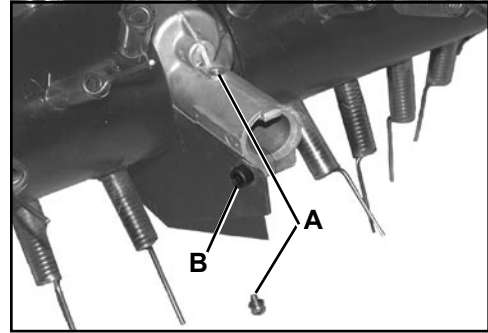

## TINE REPLACEMENT

### Level 2.

*Tools Required:* Vise Grip, 10 mm, 13 mm Open End Wrench

*Parts Required:* Thatching spring (P/N 61004725560), Screw (P/N 88995325560), plastic tube (P/N 21001325560)

Bent or broken tines should be replaced before operation for best detatching efficiency.



### WARNING

Never replace tines with engine running. Tines are sharp, wear gloves to protect your hands when replacing them.

### ***Tine Replacement***

***(Outer five (5) rows from open reel end)***

1. Hold inner tine mounting bolt from turning with 13 mm wrench inserted through open reel end.
2. Grip plastic sleeve at the base of the tine firmly with vice grip. Remove tine from bolt turning tine counter clockwise. Remove bolt.
3. Insert new bolt with star washer through reel mounting hole.

**IMPORTANT**

Star washer must be assembled on tine mounting bolt, otherwise bolt and tine will loosen on the reel.

4. Install tine onto bolt turning tine clockwise with vice grip. Tighten securely.

### ***Tine Replacement***

***(Inside tine nearest gear housing)***

5. Disconnect dethatcher attachment from Power Head/Shaft. (Refer to instructions on page 10.)
6. Rotate flex cable (C) mounted in the dethatcher assembly drive shaft housing. Turn flex cable end until front dethatcher gear housing to reel end clearance is achieved for tine bolt head access with 13 mm wrench. (See photo at right.)
7. Replace tines following steps 1 - 4 above.
8. Connect dethatcher attachment to Power Head/Shaft. (Refer to Assembly instructions on page 10).

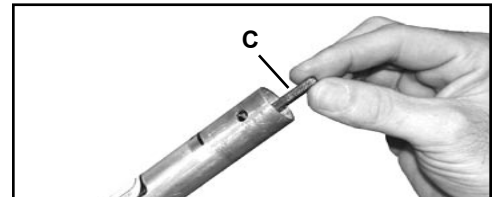
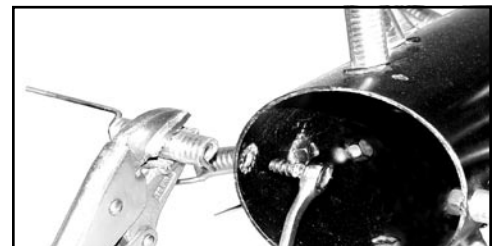
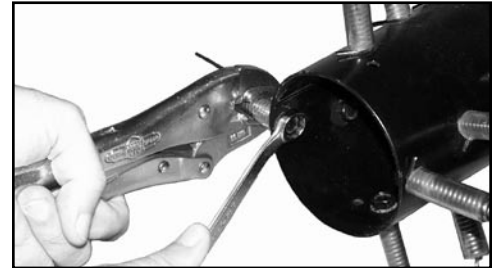

## STORAGE

1. Clean dethatcher attachment with a bristle brush and rinse with clear water.

### IMPORTANT

Do not immerse this attachment in water. Water will enter gear housing and damage gears, bearings and seals.

2. Apply thin coating of oil to metal parts to prevent rust.
3. Lubricate lower shaft assembly with grease. (Refer to Lubrication instructions on page 13.)
4. Store ProThatch Attachment in a dry place out of reach of children with lower shaft housing in a horizontal or vertical position to prevent grease loss from open shaft end.

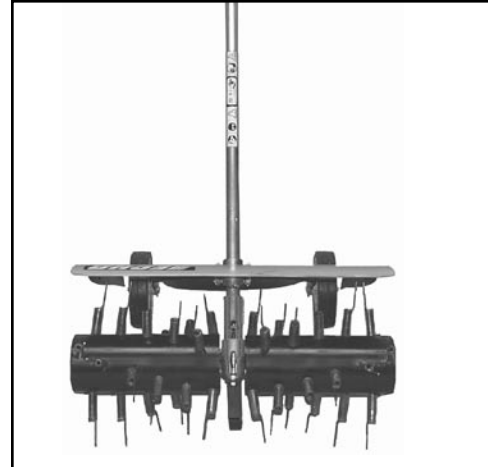

## SPECIFICATIONS

MODEL	PRO THATCH ATTACHMENT
Shaft Length	928 mm (36.5 in.)
Attachment Width	565 mm (22.2 in.)
Attachment Height	403 mm (15.9 in.)
Weight	9.6 kg. (21.14 lb.)
Drive Shaft	6.35 mm (0.25 in.)
Rotating Direction	Away from the operator viewed from the rear
Dethatcher Head	Left and right reels mounting 22 tines each, totaling 44 tines
Tines	3mm (.19 in.) spring steel
Combing Width	571 mm (22.5 in.)
Lubrication	Lithium Base Grease
Gear Reduction Ratio	42.75 : 1
Dethatcher Operating (RPM)	210
Engine Wide Open Throttle (RPM) w/attachment	7,700 - 8,500



**NOTES**

NOTES

**NOTES**

## SERVICING INFORMATION

### PARTS/SERIAL NUMBER

Genuine ECHO Parts and ECHO REPOWER™ Parts and Assemblies for your ECHO products are available only from an Authorized ECHO Dealer. When you do need to buy parts **always** have the Model Number and Serial Number of the attachment with you. You can find these numbers on the driveshaft model/serial number label. For future reference, write them in the space provided below.

Model No. \_\_\_\_\_ SN. \_\_\_\_\_

### SERVICE

Service of this product during the warranty period must be performed by an Authorized ECHO Service Dealer. For the name and address of the Authorized ECHO Service Dealer nearest you, ask your retailer or call: 1-800-432-ECHO (3246). Dealer information is also available on our Web Site. When presenting your unit for Warranty service/repairs, proof of purchase is required.

### ECHO CONSUMER PRODUCT SUPPORT

If you require assistance or have questions concerning the application, operation or maintenance of this product you may call the ECHO Consumer Product Support Department at 1-800-673-1558 from 8:30 am to 4:30 pm (Central Standard Time) Monday through Friday. Before calling, please know the model and serial number of your unit to help your Consumer Product Support Representative.

### WARRANTY REGISTRATION

You may register your Echo equipment using the warranty registration card or register on-line at [www.echo-usa.com](http://www.echo-usa.com). Registering provides a direct link between you and ECHO if we find it necessary to contact you.

### ADDITIONAL OR REPLACEMENT MANUALS

**Safety Manuals** in English/Spanish or English/French are available, free of charge, from your ECHO dealer or at [www.echo-usa.com](http://www.echo-usa.com).

**Operator's and Parts Manuals** are available by:

- Downloading free from [www.echo-usa.com](http://www.echo-usa.com)
- Purchasing from your Echo Dealer.
- Manuals are available by sending a written request stating the model number and serial number of your Echo unit, part number of the manual, your name and address, and mail to the address below.

**Safety Videos** are available from your Echo dealer. A \$5.00 shipping charge will be required for each video.

### DEALER?

Call  
**1-800-432-ECHO**  
or  
**[www.echo-usa.com](http://www.echo-usa.com)**

### CONSUMER PRODUCT SUPPORT

**1-800-673-1558**  
**8:30 - 4:30 Mon - Fri C.S.T.**

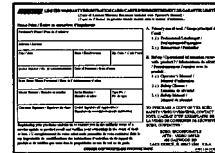

# ECHO®

ECHO, INCORPORATED  
400 OAKWOOD ROAD  
LAKE ZURICH, IL 60047-1564  
[WWW.ECHO-USA.COM](http://WWW.ECHO-USA.COM)

S08300001001/S0830099999

## Free Manuals Download Website

<http://myh66.com>

<http://usermanuals.us>

<http://www.somanuals.com>

<http://www.4manuals.cc>

<http://www.manual-lib.com>

<http://www.404manual.com>

<http://www.luxmanual.com>

<http://aubethermostatmanual.com>

Golf course search by state

<http://golfingnear.com>

Email search by domain

<http://emailbydomain.com>

Auto manuals search

<http://auto.somanuals.com>

TV manuals search

<http://tv.somanuals.com>