



Power Pruner

Operator's Manual

MODELS:

PPT-2100 TYPE 1/1E

Serial Number 503550 - 506999

PPT-2400 TYPE 1/1E

Serial Number 505900 - 518599



WARNING



The engine exhaust from this product contains chemicals known to the State of California to cause cancer, birth defects or other reproductive harm.

WARNING DANGER

Read rules for safe operation and instructions carefully. ECHO provides an Operator's Manual, which must be read and understood for proper and safe operation. Failure to do so could result in serious injury.

X7502301401

89865024661
07/98

INTRODUCTION

Welcome to the ECHO family. This ECHO product was designed and manufactured to provide long life and on-the-job-dependability. Read and understand this manual and the SAFETY MANUAL you found in the same package. You will find both easy to use and full of helpful operating tips and SAFETY messages.

WARNING DANGER

Read rules for safe operation and instructions carefully. ECHO provides an Operator's Manual and a Safety Manual. Both must be read and understood for proper and safe operation.

THE OPERATOR'S MANUAL --

contains specifications and information for operation, starting, stopping, maintenance, storage and assembly specific to this product.

THE SAFETY MANUAL —

explains possible hazards involved with the use of Power Pruner™ and what measures you should take to make their use safer.

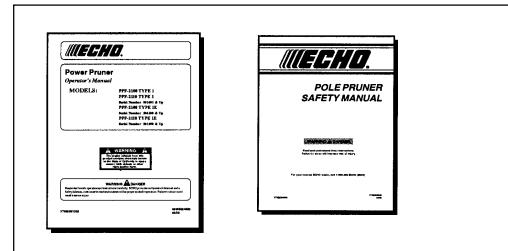

TABLE OF CONTENTS

Introduction	2	Operation	19
- The Operator's Manual	2	- Starting Cold Engine	19
- The Safety Manual	2	- Starting Warm Engine	20
Manual Safety Symbols & Important Information	3	- Stopping Engine	21
Safety	3	- Pruning Techniques	21
- General Description	3	Maintenance	22
- Decals	4	- Skill Levels	22
- International Symbols	4	- Maintenance Intervals	22
- Equipment	4	- Air Filter	23
- Fuel	5	- Fuel Filter	23
- Personal Condition & Safety Equipment	6	- Spark Plug	24
- Safe Operation	7	- Cooling System Cleaning	24
- Kickback	8	- Exhaust System	25
- Extended Operation/Extreme Conditions	9	- Carburetor Adjustment Emissions	26
Description	10	- Carburetor Adjustment Non Emissions	27
- Contents	10	- Guide Bar and Saw Chain Replacement	28
- Emission Control	10	- Filing Saw Chain	29
Specifications	13	Troubleshooting	30
Assembly	14	Storage	31
- Cutting Attachment to Drive Shaft Installation	14	Servicing Information	31
- 3' Extension Installation	14	- Parts	32
- Saw Chain Tension Adjustment	15	- Service	32
Pre-Operation	16	- ECHO Consumer Product Support	32
- Fuel	16	- Warranty Card	32
- Lubricating the Guide Bar and Saw Chain	17	- Additional or Replacement Manuals	32
- Adjusting Automatic Oiler	18	- Manual Ordering Instructions	32
- Equipment Check	18	- Supplement to Operator's Manual	33
- Determine Operation Area	19		

Specifications, descriptions and illustrative material in this literature are as accurate as known at the time of publication, but are subject to change without notice. Illustrations may include optional equipment and accessories, and may not include all standard equipment.

CopyRight© 2000 By Echo, Incorporated
All Rights Reserved.

MANUAL SAFETY SYMBOLS & IMPORTANT INFORMATION

Throughout this manual and on the product itself, you will find safety alerts and helpful, information messages preceded by symbols or key words. The following is an explanation of those symbols and key words and what they mean to you.



This symbol accompanied by the words **WARNING** and **DANGER** calls attention to an act or condition that can lead to serious personal injury to operator and bystanders.



The circle with the slash symbol means whatever is shown within the circle is prohibited.



IMPORTANT The enclosed message provides information necessary for the protection of the unit.

NOTE This enclosed message provides tips for use, care and maintenance of the unit.

SAFETY

GENERAL DESCRIPTION

IMPORTANT

See Description and Specification sections for full description and illustration of model variation in power head, and handle type.

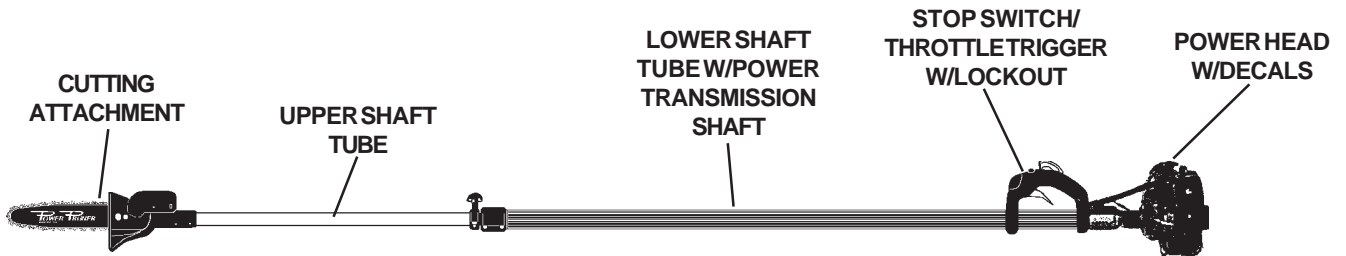

DECALS

Locate this safety decal on your unit. The complete unit illustration found in the "DESCRIPTION" section, will help you locate them. Make sure the decals are legible and that you understand and follow the instructions on them. If a decal cannot be read, a new one can be ordered from your ECHO dealer. See PARTS ORDERING instructions for specific information.

Engine Cover

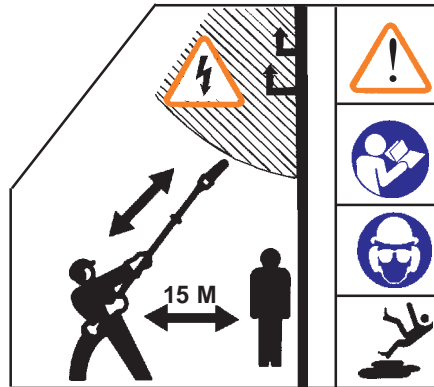

INTERNATIONAL SYMBOLS

Symbol form/shape	Symbol description/application	Symbol form/shape	Symbol description/application
	Read and understand owners manual.		Fuel and oil mixture
	Wear eyes, ears and head protection		Finger Severing
	Emergency stop		Carburetor adjustment - Low speed mixture
	Wear hand protection. Use two handed.		DO NOT smoke near fuel.
	Engine choke control.		Ignition ON/OFF
	Chain lubrication		Primer bulb

Symbol form/shape	Symbol description/application	Symbol form/shape	Symbol description/application
	Hot Surface		Carburetor adjustment - High speed mixture
	Safety/Alert		Carburetor adjustment - Idle speed
	Avoid all power lines. This unit is not insulated against electrical current.		Do not operate closer than 15 M (50 ft.) from electrical hazards.
	Keep bystanders at least 15 meters (50 feet) away.		Plan retreat path from falling objects.
	DO NOT allow flames or sparks near fuel.		Wear slip resistant foot wear.

EQUIPMENT

Before operation a complete check of the unit must be performed;

- Check unit for loose/missing nuts, bolts and screws. Tighten and/or replace as needed.
- Inspect fuel lines, tank and area around carburetor for fuel leaks. DO NOT operate unit if leaks are found.
- Never adjust the guide bar or saw chain when the engine is operating.

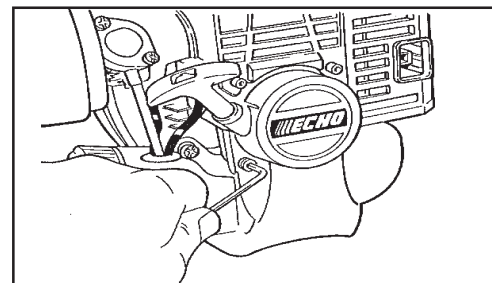

Guide Bar and Saw Chain

WARNING  DANGER

- Serious injury may result from the use of non approved guide bar and saw chain combinations. Read and comply with all safety instructions listed in this manual.
- ECHO, INC. will not be responsible for the failure of cutting devices or accessories which have not been tested and approved by ECHO for use with this unit.

- Check that the cutting attachment, guide bar and saw chain is firmly attached and in safe operating condition.
- Only use ECHO approved guide bar and saw chain.
- Only use one ECHO approved extension on the pruner.
- Do not hit rocks, stones, tree stumps and other foreign objects with the saw chain.
- Do not cut into the ground with the saw chain.
- If cutting attachment end strikes an obstruction, stop engine immediately and inspect saw chain for damage.
- Do not operate with a dull, fractured or discolored saw chain.
- Remove all foreign objects from work area.
- Always cover the guide bar and saw chain with guide bar cover during transportation and in storage.

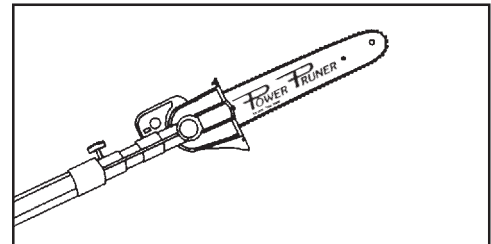

FUEL

WARNING  DANGER

Fuel is **VERY** flammable. Use extreme care when mixing, storing or handling, or serious personal injury may result.

- Use an approved fuel container.
- **DO NOT** smoke near fuel.
- **DO NOT** allow flames or sparks near fuel.
- Fuel tanks/cans may be under pressure. Always loosen fuel caps slowly allowing pressure to equalize.
- **NEVER** refuel a unit when the engine is **HOT!**
- **NEVER** refuel a unit with the engine running.
- **DO NOT** fill fuel tanks indoors. **ALWAYS** fill fuel tanks out doors over bare ground.
- Securely tighten fuel cap after refueling.
- Inspect for fuel leakage. If fuel leakage is found, do not start or operate unit until leakage is repaired.



After Refueling;

- Wipe any spilled fuel from the unit.
- Move at least 3 M (10 ft.) from refueling location before starting.

After Use;

- **DO NOT** store a unit with fuel in its tank. Leaks can occur. Return unused fuel to an approved fuel storage container.

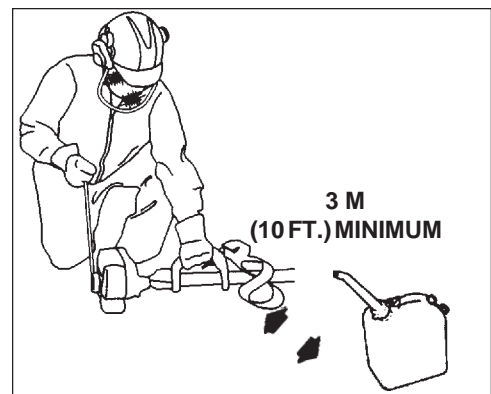

PERSONAL CONDITION & SAFETY EQUIPMENT

WARNING DANGER

Power Pruner users risk injury to themselves and others if the Power Pruner is used improperly and or safety precautions are not followed. Proper clothing and safety gear must be worn when operating a Power Pruner.

Physical Condition --

Your judgment and physical dexterity may not be good:

- if you are tired or sick,
- if you are taking medication,
- if you have taken alcohol or drugs.

Operate unit only if you are physically and mentally well.



Eye Protection --

Eye protection that meet ANSI Z87.1 and CE requirements were included with your Power Pruner. Wear them whenever you operate the Power Pruner.

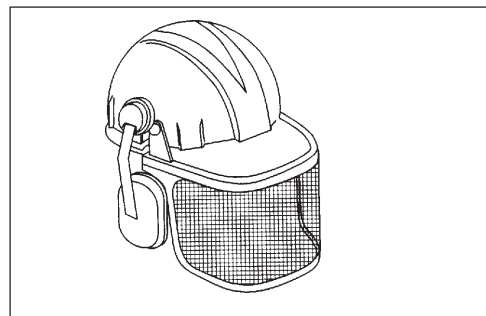

Face & Head Protection --

When trimming overhead, always wear head protection meeting ANSI Z89.1 or CE requirements with a full face shield. Head protection with full face shield will help protect you from falling branches and debris.

Hand Protection --

Wear no-slip, heavy duty work gloves to improve your grip on the power pruner handles. Gloves also reduce the transmission of machine vibration to your hands. Special vibration reducing gloves such as Echo's Pro-Comfort are designed to provide additional comfort.

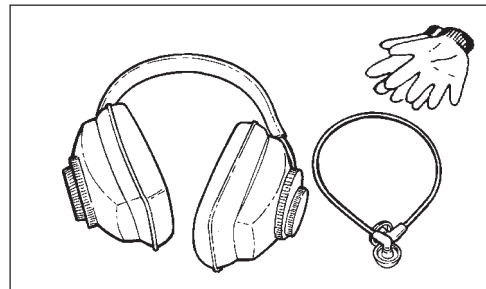

Hearing Protection --

Wear hearing protection. OSHA requires the use of hearing protection if this unit is used 2 hours per day or more. ECHO recommends wearing hearing protection whenever unit is used.

Proper Clothing --

Wear snug fitting, durable clothing;

- Pants should have long legs, shirts with long sleeves.
- **DO NOT WEAR SHORTS,**
- **DO NOT WEAR TIES, SCARVES, JEWELRY.**

Wear sturdy work shoes with non-skid soles;

- **DO NOT WEAR OPEN TOED SHOES,**
- **DO NOT OPERATE UNIT BAREFOOTED.**

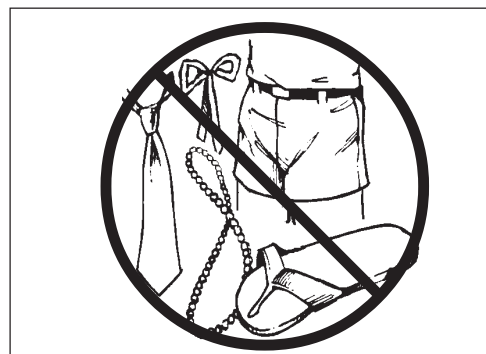

Hot Humid Weather --

Heavy protective clothing can increase operator fatigue which may lead to heat stroke. Schedule heavy work for early morning or late afternoon hours when temperatures are cooler.

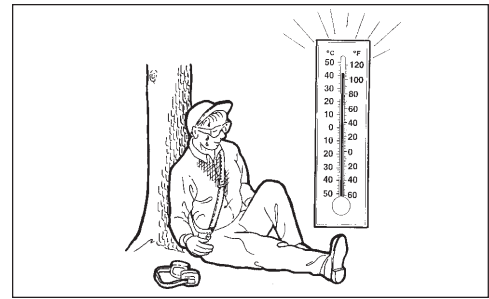

SAFE OPERATION

WARNING DANGER

All over head electrical conductors and communications wires can have electricity flow with high voltages. Never touch wires directly or indirectly when pruning, otherwise serious injury or death may result.

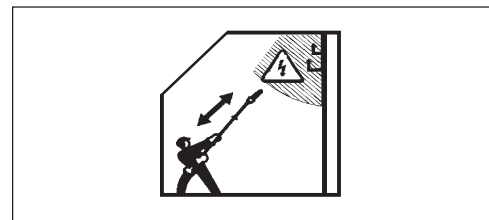

Determine Operation Area

- Provide all operators of this equipment with the Operator's Manual and instructions for safe operation.
- Do not operate this product indoors or in inadequately ventilated areas.
- Review the area to be trimmed. Look for hazards that could contribute to unsafe conditions. DO NOT operate unit if any wires (power, telephone, cable, etc.) are closer than 15 M (50 ft.) to any part of the operator or unit.
- Spectators and fellow workers must be warned, and children and animals prevented from coming nearer than 15 M (50 ft.) while the Power Pruner is in use.
- Avoid all power lines. This unit is not insulated against electrical current.

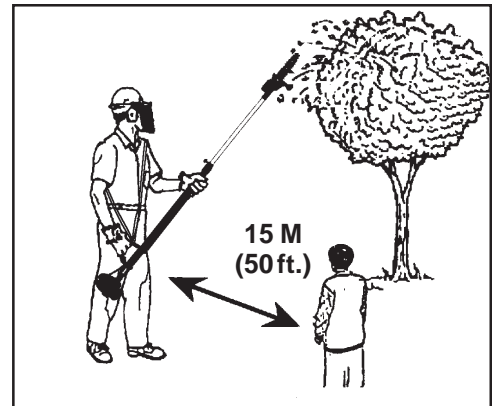

Operation

Use Proper Clothing & Equipment

- Before starting the unit, equip yourself and any other person working within the 15 M (50 ft.) Safety Zone with the required Protective Equipment and clothing.
- Always wear head protection with full face shield to help protect against falling branches and debris.

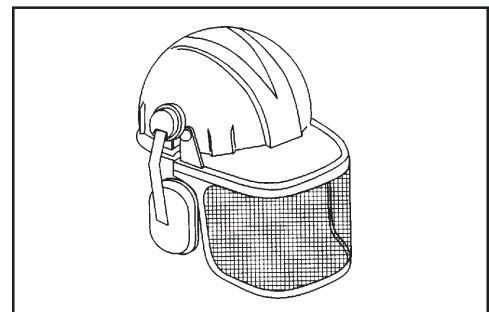

Avoid Hot Surfaces

- During operation, the complete unit, especially the power head, muffler area and cutting attachment may become very hot, too hot to touch. Avoid contact during and immediately after operation.

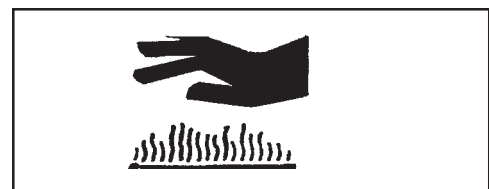

Keep A Firm Grip

- Grip Power Pruner with both hands with thumbs and fingers tightly encircling the handle, and lower shaft tube.

Keep A Solid Stance

- Maintain footing and balance at all times. Do not stand on slippery, uneven or unstable surfaces. Do not work in odd positions or on ladders. Do not overreach.
- Operate the Power Pruner only from the ground or out of an approved bucket lift.
- Always evaluate the branches to be pruned for hazards such as loose dead branches which may fall and strike the operator or helpers. Remove hazards before pruning.
- Cut branches bounce when striking ground.
- Plan retreat path from falling objects.
- Check that shoulder harness is adjusted for safe, comfortable operation. See picture at right for proper adjustment.
- Turn the Power Pruner off when moving from tree to tree.
- Avoid any contact with saw chain.

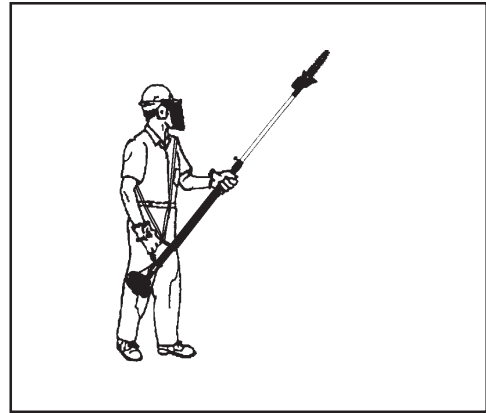

KICKBACK

WARNING **DANGER**

Kickback can lead to dangerous loss of control of the Power Pruner and result in serious injury to the operator or any one standing close by.

Kickback may occur when the moving saw chain at the nose or tip of the guide bar touches an object, or when the wood closes in and pinches the saw chain in the cut. In some cases this may cause a lightning-fast reverse action, kicking the guide bar and saw chain up and back or down and back towards the operator. Either of these reactions may cause the operator to lose control of the Power Pruner which could result in serious personal injury.

With a basic understanding of kickback, you can reduce or eliminate the element of surprise which contributes to accidents.

Hold the Power Pruner firmly with both hands. Be aware of the down and outward path the pruner will take after the cut is made.

Avoid contact of the guide bar tip with any object while the saw chain is moving.

Cut only wood. Avoid striking concrete, metal, wire, or other obstructions which could cause kickback or damage to the saw chain.

If the saw chain does strike a foreign object, immediately stop the engine, inspect and repair the Power Pruner if necessary.

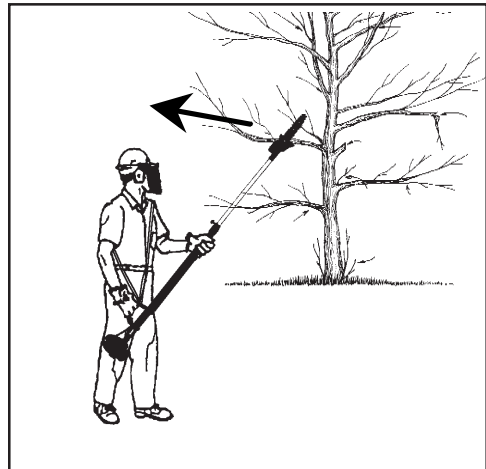

EXTENDED OPERATION/EXTREME CONDITIONS

Vibration and Cold

It is believed that a condition called Raynaud's Phenomenon, which affects the fingers of certain individuals may be brought about by exposure to vibration and cold. Exposure to vibration and cold may cause tingling and burning sensations followed by loss of color and numbness in the fingers. The following precautions are strongly recommended because the minimum exposure which might trigger the ailment is unknown.

- Keep your body warm, especially the head, neck, feet, ankles, hands and wrists.
- Maintain good blood circulation by performing vigorous arm exercises during frequent work breaks and also by not smoking.
- Limit the hours of operation. Try to fill each day with jobs where operating the trimmer or other hand-held power equipment is not required.
- If you experience discomfort, redness and swelling of the fingers followed by whitening and loss of feeling, consult your physician before further exposing yourself to cold and vibration.

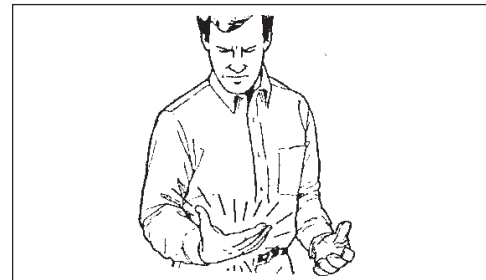
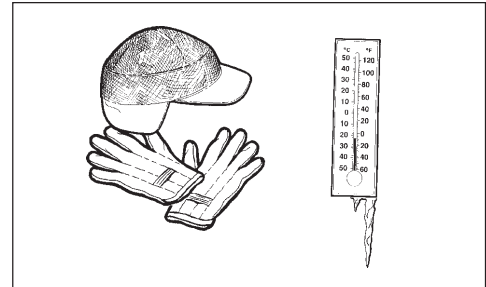

Repetitive Stress Injuries

It is believed that overusing the muscles and tendons of the fingers, hands, arms and shoulders may cause soreness, swelling, numbness, weakness and extreme pain in those areas. Certain repetitive hand activities may put you at a high risk for developing a Repetitive Stress Injury (RSI). An extreme RSI condition is Carpal Tunnel Syndrome (CTS), which could occur when your wrist swells and squeezes a vital nerve that runs through the area. Some believe that prolonged exposure to vibration may contribute to CTS. CTS can cause severe pain for months or even years.

To reduce the risk of RSI/CTS, do the following:

- Avoid using your wrist in a bent, extended or twisted position. Instead try to maintain a straight wrist position. Also, when grasping, use your whole hand, not just the thumb and index finger.
- Take periodic breaks to minimize repetition and rest your hands.
- Reduce the speed and force with which you do the repetitive movement.
- Do exercises to strengthen the hand and arm muscles.
- See a doctor if you feel tingling, numbness or pain in the fingers, hands, wrists or arms. The sooner RSI/CTS is diagnosed, the more likely permanent nerve and muscle damage can be prevented.

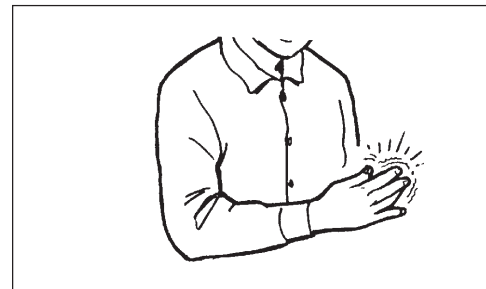

DESCRIPTION

Due to packaging restriction the ECHO product you have purchased requires some assembly.

After opening the carton, check for damage. Immediately notify your retailer or ECHO Dealer of damaged or missing parts. Use the contents list to check for missing parts.

CONTENTS LIST

- ___ Power Head
- ___ Shaft Tube Assembly
- ___ Cutting Attachment W/ Guide Bar and Saw Chain
- ___ Plastic Bag
- ___ Operator's Manual
- ___ How to Prune Manual
- ___ Warranty Registration Card
- ___ Warranty Statement
- ___ Plastic Bag
- ___ T-Wrench (combination screwdriver/spark plug socket)
- ___ Combination Cross Head / Slotted L-Wrench
- ___ 3 mm hex wrench
- ___ 8 x 10 mm Spanner
- ___ Safety Glasses
- ___ 2-Stroke Oil Bottle (2.6 oz.)
- ___ Shoulder Harness
- ___ Guide Bar Cover

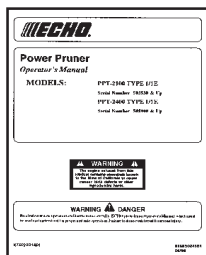
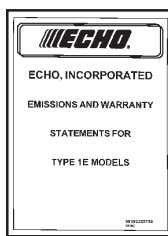

EMISSION CONTROL - Emissions Models

The emission control system for this engine is EM (Engine Modification).

IMPORTANT ENGINE INFORMATION

ENGINE FAMILY: TEH024UB24RA

DISPLACEMENT: 23.6cc

THIS ENGINE MEETS U.S. EPA PH1 AND 1995-1998 CALIFORNIA EMISSION REGULATIONS FOR ULGE ENGINES. REFER TO OWNER'S MANUAL FOR MAINTENANCE SPECIFICATIONS AND ADJUSTMENTS.

KIORITZ CORP.

Emission Control Label (located on Engine) (EXAMPLE ONLY, information on label varies by FAMILY).

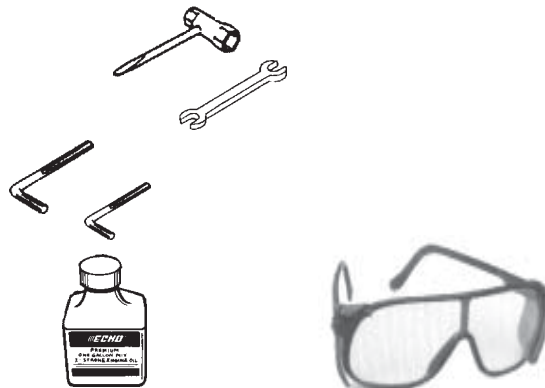

ECHO LIMITED WARRANTY REGISTRATION CARD/TARJETA DE INSCRIPCIÓN DE GARANTÍA LIMITADA	
Copy of Limited Warranty Statement included with Operator's Manual / Copia de Manual del Operador en folios de 9 a 10 de la descripción de la garantía (versión)	
BASE MODEL: 23.6cc ECHO 23.6cc ECHO	
REGISTRATION INFORMATION: NAME: _____ ADDRESS: _____ PHONE: _____ FAX: _____ CITY: _____ STATE: _____ ZIP: _____ COUNTRY: _____	
DATE OF PURCHASE: _____ DEALER: _____ DEALER ADDRESS: _____ DEALER PHONE: _____ DEALER FAX: _____ DEALER CITY: _____ DEALER STATE: _____ DEALER ZIP: _____	
REGISTRATION INFORMATION: MODEL: _____ SERIAL: _____ YEAR: _____ TYPE: _____ COLOR: _____ FINISH: _____ WEIGHT: _____ POWER: _____ VOLTAGE: _____ FREQUENCY: _____ SPEED: _____ LENGTH: _____ WIDTH: _____ HEIGHT: _____ DIAMETER: _____ THICKNESS: _____ AREA: _____ VOLUME: _____ SURFACE AREA: _____ PERIMETER: _____ CIRCUMFERENCE: _____ AREA: _____ VOLUME: _____ SURFACE AREA: _____ PERIMETER: _____ CIRCUMFERENCE: _____	
REGISTRATION INFORMATION: MODEL: _____ SERIAL: _____ YEAR: _____ TYPE: _____ COLOR: _____ FINISH: _____ WEIGHT: _____ POWER: _____ VOLTAGE: _____ FREQUENCY: _____ SPEED: _____ LENGTH: _____ WIDTH: _____ HEIGHT: _____ DIAMETER: _____ THICKNESS: _____ AREA: _____ VOLUME: _____ SURFACE AREA: _____ PERIMETER: _____ CIRCUMFERENCE: _____	

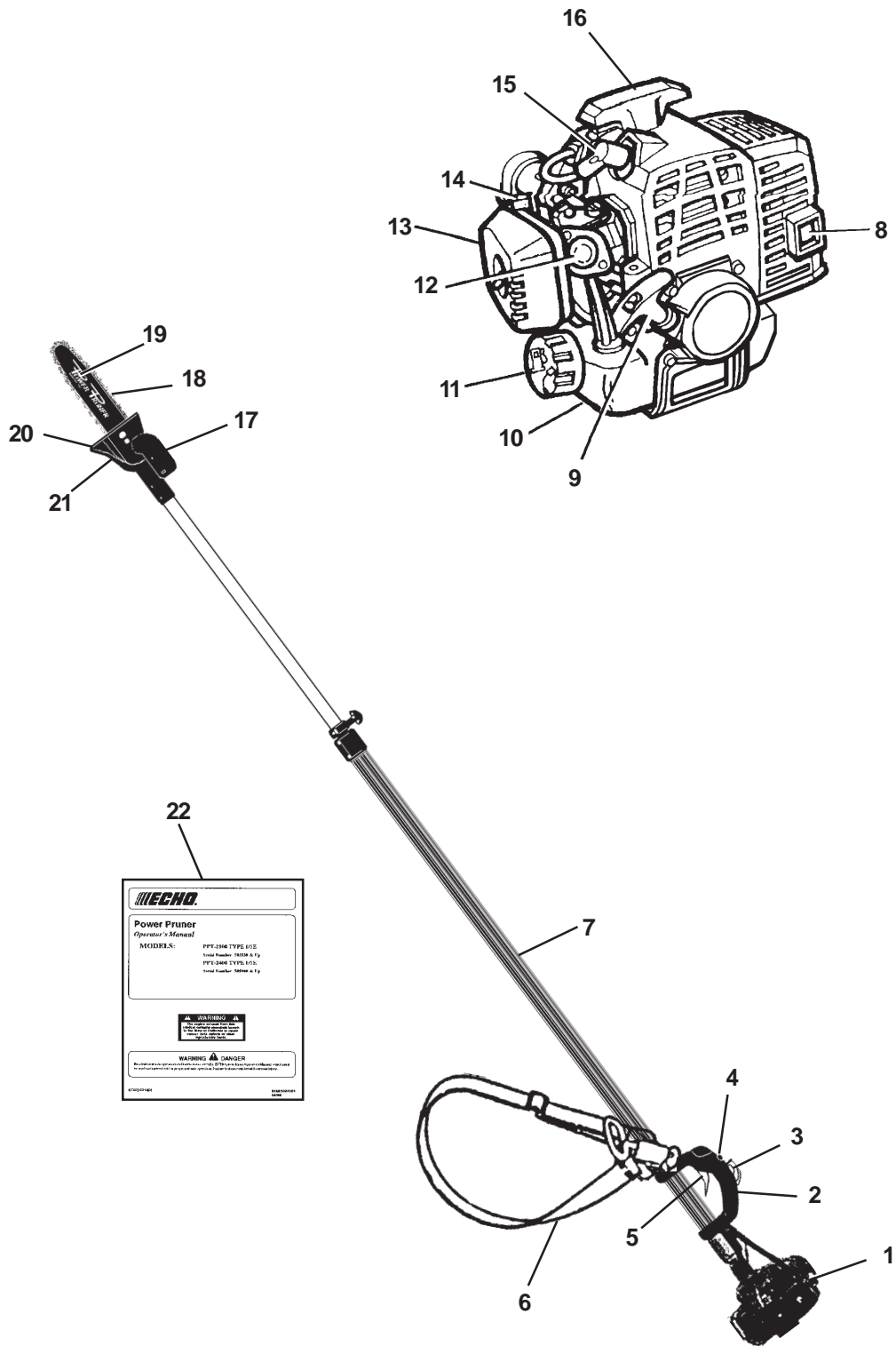

1. **POWER HEAD** - Includes the Engine, Clutch, Fuel System, Ignition System and Starter.
2. **REAR HANDLE ASSEMBLY** - Sturdy handle for right hand placement. Includes stop switch and throttle trigger.
3. **THROTTLE TRIGGER LOCKOUT** - This lever must be depressed before throttle trigger can be operated.
4. **STOP SWITCH** - Mounted on top of handle assembly. Move switch forward to run, back to stop.
5. **THROTTLE TRIGGER** - Spring loaded to return to idle when released. During acceleration press trigger gradually for best operating technique.
6. **SHOULDER HARNESS** - An adjustable strap that suspends the unit from the operator.
7. **LOWERSHAFT TUBE** - Durable fiberglass mesh housing.
8. **MUFFLER, SPARK ARRESTER** - The muffler controls the exhaust noise while the spark arrestor prevents hot, glowing particles of carbon from leaving the muffler where they could possibly start a fire.
9. **RECOIL STARTER** - Pull recoil handle slowly until starter engages, then quickly and firmly. When engine starts return handle slowly. **DO NOT** let handle snap back or damage will occur.
10. **FUEL TANK** - Contains fuel and fuel filter.
11. **FUEL TANK CAP** - Covers and seals fuel tank opening.
12. **PRIMER BULB** - Pumping primer bulb before starting engine draws fresh fuel from the fuel tank priming the carburetor for starting. Pump the bulb 10 times until fuel is visible in clear fuel return line.
13. **AIR CLEANER ASSEMBLY** - Contains replaceable air filter element.
14. **CHOKE** - Located above air cleaner housing. Controls operation of choke. Move lever to start position (Close Choke) and back to run position (Open Choke).
15. **SPARK PLUG** - Provides spark to ignite fuel mixture.
16. **ARM REST** - Provides arm rest during operation and protects arm from hot engine.
17. **AUTOMATIC OILER ASSEMBLY** - Self oiling. Use high quality, low viscosity, non detergent bar and chain oil.
18. **SAW CHAIN** - 90 SG 9.53 mm (3/8 in.) low profile Oregon saw chain. Runs approximately 609.6 m/min. (2000 ft/min) at full throttle.
19. **GUIDEBAR** - 254 mm (10 in.) guide bar (PPT-2100), 305 mm (12 in.) guide bar (PPT-2400).
20. **CUTTING SHOE** - Used to capture and stabilize branch while cutting. Place cutting shoe against branch, accelerate and lower saw chain into branch.
21. **CUTTING ATTACHMENT** - Sealed, gear ratio is 1.5:1 reduction.
22. **OPERATORS MANUAL** - Read and understand this manual before operation. Keep manual in a safe location for future reference, i.e., operation, maintenance, storage and specifications.

SPECIFICATIONS

MODEL	PPT-2100	PPT-2400
Length (Standard)	2286 mm (90.0 in.)	2743 mm (108.0 in.)
Length (Extended)	3410 mm (134.25 in.)	3886 mm (153.0 in.)
Width	222 mm (8.75 in.)	222 mm (8.75 in.)
Height	229 mm (9.0 in.)	229 mm (9.0 in.)
Weight (dry)	7.4 kg (16.3 lb.)	7.7 kg (16.9 lb.)
Engine Type	Air cooled, two-stroke, single cylinder gasoline engine	
Bore	32.2 mm (1.268 in.)	34.0 mm (1.339 in.)
Stroke	26.0 mm (1.04 in.)	26.0 mm (1.04 in.)
Displacement	21.2 cc (1.29 cu. in.)	23.6 cc (1.44 cu. in.)
Exhaust System	Spark Arrestor Muffler	
Carburetor	Diaphragm, w/primer bulb	
Ignition System	CDI (capacitor discharge ignition)	
Spark Plug	NGK BPM-7A Gap 0.65 mm (0.026 in.)	NGK BPM-7Y Gap 0.65 mm (0.026 in.)
Fuel	Mixed (Gasoline and Two-stroke Oil)	
Fuel/Oil Ratio	50:1 ECHO High Performance, two-stroke air cooled engine oil	
Gasoline	89 Octane unleaded. DO NOT use fuel containing methyl alcohol, more than 10% ethyl alcohol or 15% MTBE.	
Oil	50:1 ECHO High Performance, two-stroke air cooled engine oil	
Fuel Tank Capacity	0.4 lit. (14.0 US fl. oz.)	
Starter System	Automatic Recoil Starter	
Clutch	Centrifugal Type	
Sprocket Type	6 tooth spur, 9.53 mm (3/8") pitch	
Power Transmission Shaft Assembly	Aluminum Extrusion	
Gear Case Ratio	1.5:1	
Oiling System	Automatic	
Saw Chain Oil Capacity	59 ml (2.0 oz.)	
Handle	Right hand grip w/throttle trigger and lockout	
Shoulder Harness	Standard	
Idle Speed (RPM)	2600 - 3100	
Wide Open Throttle Speed (RPM)	8000 - 9000	11,000 - 12,000
Guide Bar and Saw Chain (90SG)	254 mm (10 in.) ; 9.53 mm (3/8") pitch	305 mm (12 in.) ; 9.53 mm (3/8") pitch

Specifications, descriptions and illustrative material in this literature are as accurate as known at the time of publication, but are subject to change without notice. Illustrations may include optional equipment and accessories, and may not include all standard equipment.

ASSEMBLY

SHAFT TUBE / POWER HEAD

Tools Required: T-wrench, 8-10 mm Wrench, Combination L-Wrench

Parts Required: Power Head, Shaft Tube Assembly; Cutting Attachment

1. Loosen bolt (A).
2. Match square socket in engine shaft with square power transmission shaft (B) and slide together until engine rests against the machine surface of lower shaft tube housing coupler (C).
3. Rotate lower shaft tube housing to align engine and rear handle assembly in an upright position.
4. Tighten bolt (A) securely so engine will not rotate on lower shaft tube.

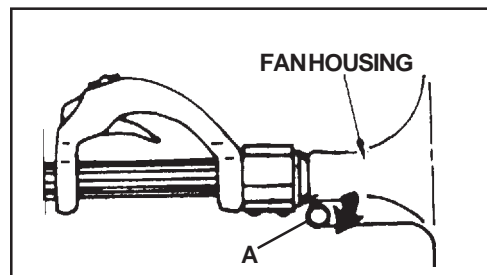
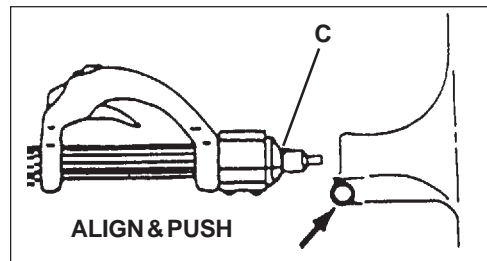
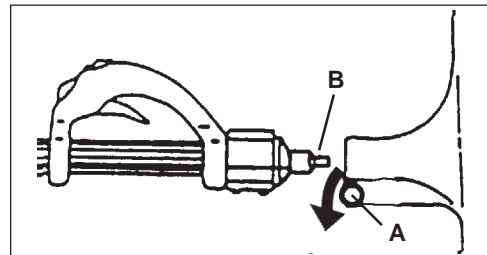
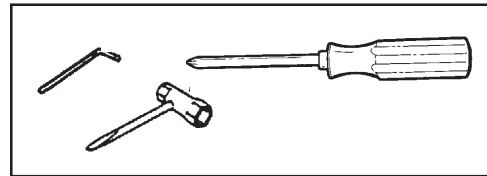

CUTTING ATTACHMENT TO SHAFT TUBE INSTALLATION

WARNING DANGER

Saw Chain is sharp! Always wear gloves when handling assembly, otherwise serious personal injury may result.

1. Loosen the four (4) screws (D) and locator screw (E) on cutting attachment.

NOTE

Do not remove locator screw (E) completely from cutting attachment, otherwise inner lock nut will come off and be lost.

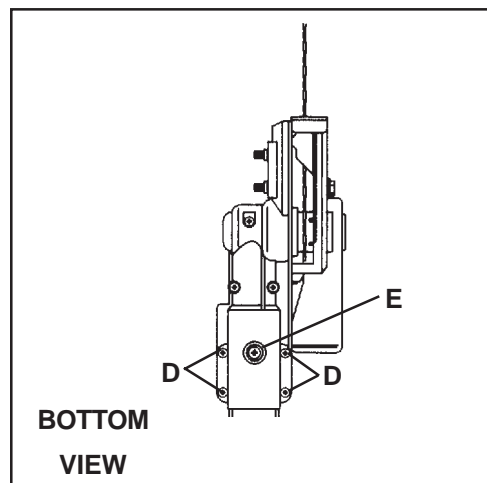

2. Loosen center clamp knob (F) turning counter clockwise.
3. Pull upper shaft tube (G) out of fiberglass lower shaft tube 127-152 mm (5-6 in.), then slide (G) back into fiberglass lower shaft tube exposing inner power transmission shaft (H). Align and join star shaped drive end of inner power transmission shaft (H) with cutting attachment shaft (I).
4. Align ridges on upper shaft tube (G) with seams in cutting attachment.
5. Slide together aligning locating screw (J) in cutting attachment with locating hole (K) in upper shaft tube.
6. Tighten locator screw (E). Tighten four (4) cutting attachment screws (D).
7. Extend upper shaft tube to desired length. Tighten center clamp knob (F) turning clockwise.

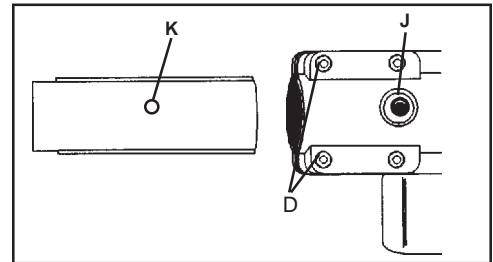
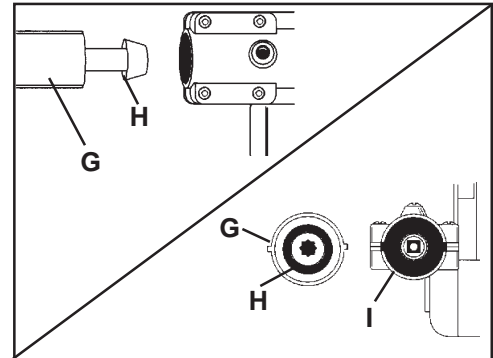
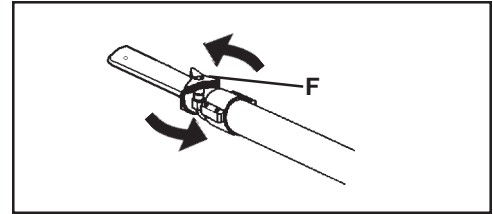

THROTTLE LINKAGE INSTALLATION

NOTE

The engine is delivered separated from shaft tube. The throttle linkage and stop switch wires are attached to the rear handle.

1. Loosen outer 10mm nut (E) on throttle linkage.
2. Insert throttle linkage in fan cover slot (A).
3. Finger tighten nut (E) and attach the inner linkage to the swivel (B) on the carburetor throttle plate.

NOTE

It is important that the head of the throttle linkage fits inside the slot well of the swivel (B).

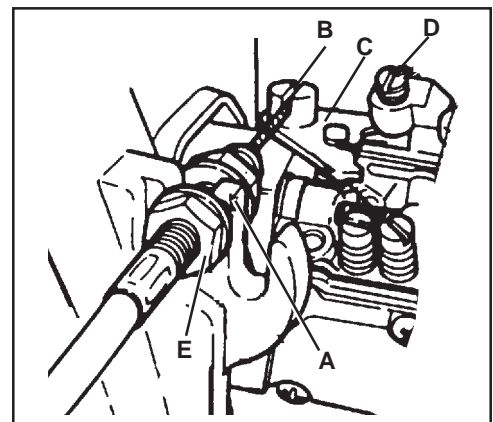

- Tighten the 10mm linkage nuts (E).
- Check throttle for freedom of movement and make sure it returns to idle position. If the throttle linkage does not allow the carburetor throttle plate (C) to return to idle against idle screw (D), loosen linkage nuts; turn throttle linkage nut (E) counter clockwise until throttle plate (C) rests against idle screw (D). Hold linkage nut (E) from turning and tighten other linkage nut.

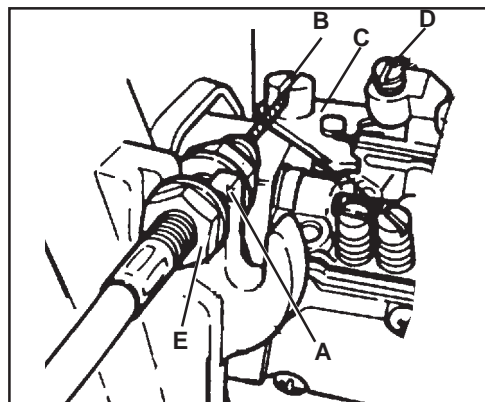

- Connect ground wire terminal under screw (F) on fan housing.
- Connect stop switch wire to stop wire (G) on engine.

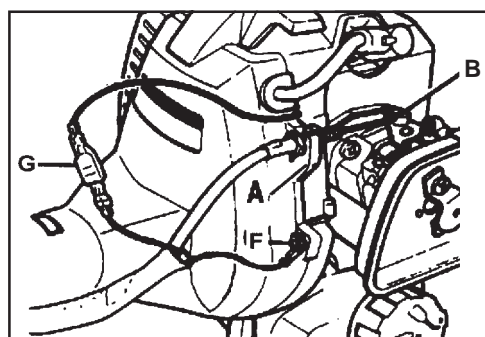

SAW CHAIN TENSION ADJUSTMENT

WARNING DANGER

Always wear work gloves when handling saw chain, otherwise serious personal injury may result.

To Adjust Saw Chain Tension.

- Loosen two (2) 11 mm (7/16 in.) guide bar bolts (A) located on cutting attachment using the adjustment wrench provided.
- Turn saw chain tensioning screw (B) (located next to guide bar in sprocket cover) clockwise to tighten saw chain on guide bar. Turning screw counter clockwise will loosen saw chain on guide bar.
- Tighten guide bar bolt firmly, but not so much that the head starts to distort. Move saw chain backwards on guide bar by hand. Saw chain should move freely on bar if it is in proper mesh with sprocket.

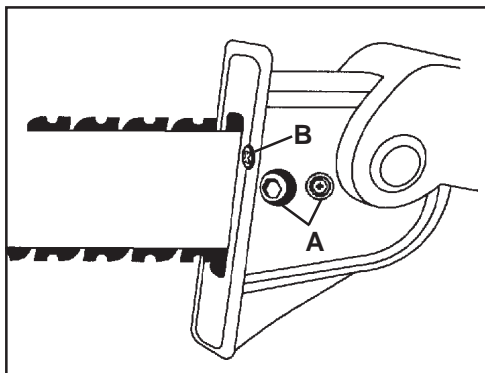

Keep the saw chain lubricated and properly adjusted and the guide bar bolts tightened firmly at all times. If saw chain is difficult to rotate or binds on guide bar, it is too tight.

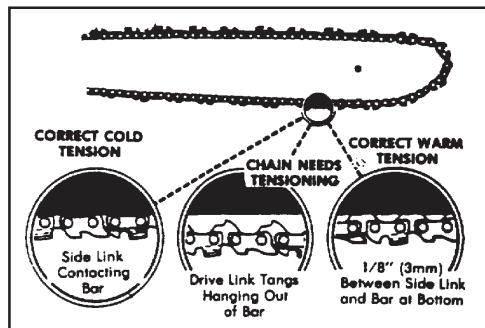

PRE-OPERATION

FUEL

Fuel Requirements

Gasoline - Use 89 Octane [$\frac{R+M}{2}$] gasoline or gasohol known to be good quality. Gasohol may contain up to 10% Ethyl (grain) alcohol or 15% MTBE (methyl tertiary-butyl ether). Gasohol containing methanol (wood alcohol) is **NOT** approved.

Two-Stroke Oil - A two-stroke engine oil meeting ISO-L-EGD Standard (ISO/CD 13738), must be used. Echo brand Premium 50:1 oil meets this standard. Engine problems due to inadequate lubrication caused by failure to use an ISO-L-EGD approved oil, such as Echo Premium 50:1 Two-stroke Oil, will void the two-stroke engine warranty. (Emission related parts only are covered for two years, regardless of two-stroke oil used, per the statement listed in the EPA Phase I/California Emission Defect Warranty Explanation.)

Mixing - Follow directions on the oil container.

Handling Fuel

WARNING DANGER

Fuel is **VERY** flammable. Use extreme care when mixing, storing or handling, or serious personal injury may result.

- Use an approved fuel container.
- DO NOT smoke near fuel.
- DO NOT allow flames or sparks near fuel.
- Fuel tanks/cans may be under pressure. Always loosen fuel caps slowly allowing pressure to equalize.
- NEVER refuel a unit when the engine is HOT!
- NEVER refuel a unit with the engine running.
- DO NOT fill fuel tanks indoors. ALWAYS fill fuel tanks out doors over bare ground.
- Securely tighten fuel cap after refueling.
- Inspect for fuel leakage. If fuel leakage is found, do not start or operate unit until leakage is repaired.

After Refueling;

- Wipe any spilled fuel from the unit.
- Move at least 3 M (10 ft.) from refueling location before starting the engine.

After use;

- DO NOT store a unit with fuel in its tank. Leaks can occur. Return unused fuel to an approved fuel storage container.

Storage -

Fuel storage laws vary by locality. Contact your local government for the laws affecting your area. As a precaution, store fuel in an approved, air tight container. Store in a well ventilated, unoccupied building, away from sparks and flames. Do not store fuel longer than 30 days.

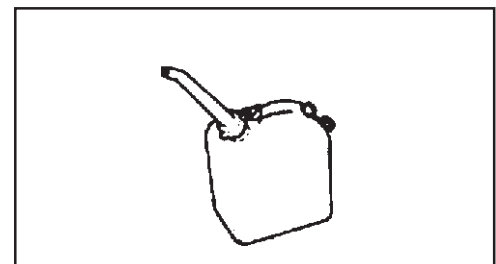
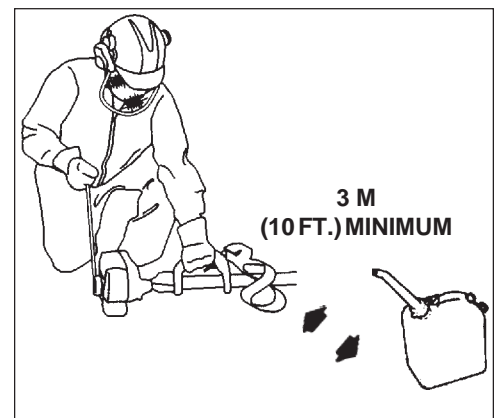
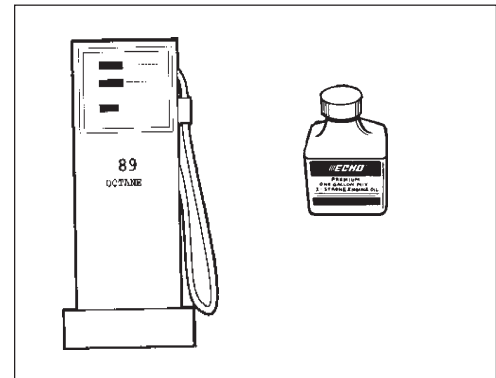

IMPORTANT

Stored fuel ages. Do not mix more fuel than you expect to use in thirty (30) days, ninety (90) days when a fuel stabilizer is added.

IMPORTANT

Stored two-stroke fuel may separate. ALWAYS shake fuel container thoroughly before each use.

S	M	T	W	T	F	S
1	2	3	4	5	6	7
8	9	10	11	12	13	14
15	16	17	18	19	20	21
22	23	24	25	26	27	28
29	30	31				

AUTOMATIC OILING SYSTEM

1. Turn oil fill cap 45° counter clockwise and lift to remove.
2. Fill with a quality, low viscosity, guide bar and saw chain oil.

IMPORTANT

To prevent plastic deterioration, do not use synthetics or silicones based oil.

3. Set rate indicator (A) to center by turning adjustment wheel (B).
4. Adjust for minimum oil rate by turning adjustment wheel (B). (Very little visible oil on the saw chain will provide sufficient lubrication).

NOTE

Proper oiling rate will use one reservoir of oil for each tank of gas.

IMPORTANT

Do not force adjustment wheel after indicator has reached the end of travel window.

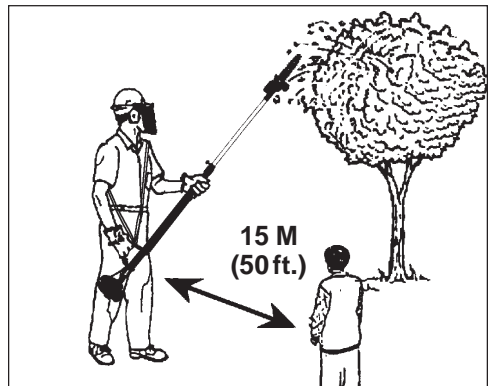
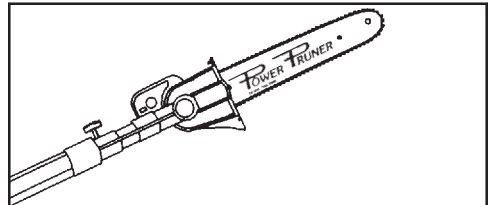
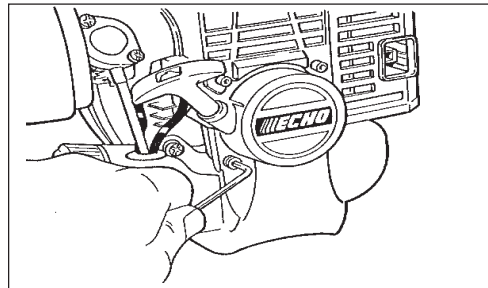
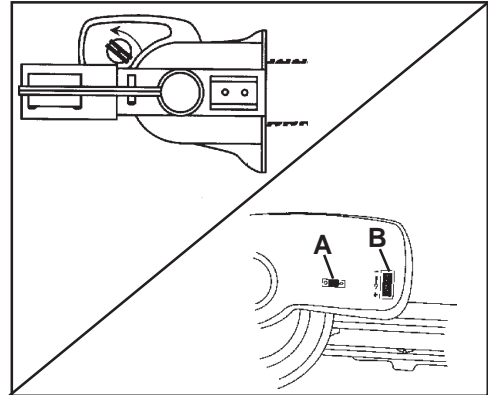

EQUIPMENT CHECK

Before operation a complete check of the unit must be performed;

- Check unit for loose/missing nuts, bolts and screws. Tighten and/or replace as needed.
- Inspect fuel lines, tank and area around carburetor for fuel leaks. DO NOT operate unit if leaks are found.
- Check that the cutting attachment is firmly attached and the saw chain is correctly tensioned on the guide bar. Dull, loose or damaged saw chain should not be used. Refer to page 29 for correct Filing Saw Chain procedures.
- Check that shoulder harness is adjusted for safe, comfortable operation. See figure at right for proper adjustment.

DETERMINE OPERATION AREA

- Before starting the unit, equip yourself and fellow workers in the 15 M (50 ft.) safety zone with the required protective equipment and clothing.
- Review the area to be trimmed. Look for hazards that could contribute to unsafe conditions such as overhead electrical lines or dead branches.
- Spectators, children and animals must be prevented from coming nearer than 15 M (50 ft.) while the pruner is in use.

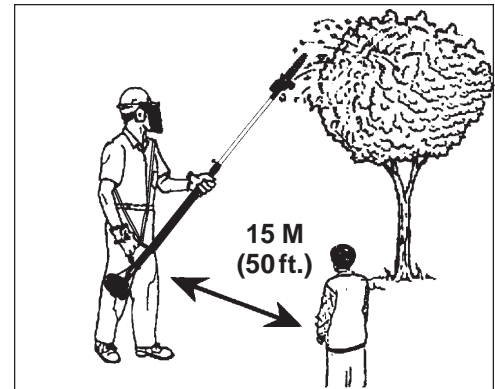

OPERATION

- Provide all operators of this equipment with the Operator's Manual and instructions for safe operation.
- Before starting the unit, equip yourself and any other person working within the 15 M (50 ft.) Safety Zone with the required Protective Equipment and clothing.
- Always evaluate the area being cut for overhead hazards, such as dead branches which may fall and strike the operator or helpers.
- Be aware of branches bouncing when striking the ground.
- Larger branches should be removed in sections.
- During operation, the complete unit, especially the shaft tube and the cutting attachment may become very hot, too hot to touch. Avoid contact during and immediately after operation.

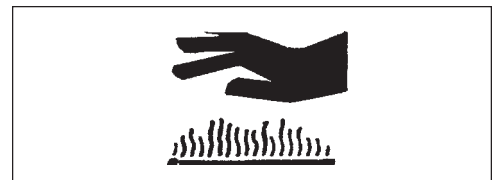
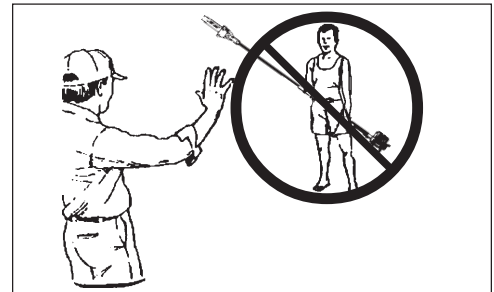

STARTING COLD ENGINE

WARNING DANGER

The cutting attachment should not rotate at idle. If cutting attachment moves, readjust carburetor according to "Carburetor Adjustment" instructions in this manual or see your ECHO Dealer, otherwise serious personal injury may result.

1. Stop Switch - Start/Run.
Move stop switch button (A) forward away from the STOP position.
2. Choke Lever - Cold Start.
Move choke (B) to "Cold Start" Position.
3. Primer Bulb-Prime.
Pump primer bulb (C) 10 times. Fuel will be visible and flow freely in the clear fuel tank return line.

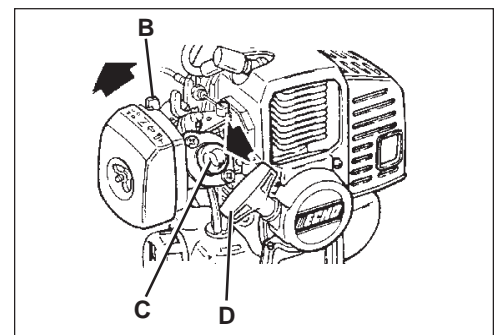
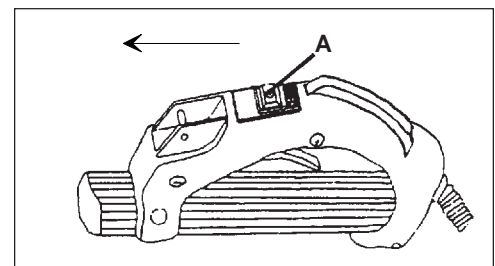

WARNING DANGER

Inspect starting area for hazards such as rocks, glass, debris etc. which could be contacted by the cutting attachment when starting. Keep helpers and bystanders at least 15 M (50 ft.) from starting area, otherwise serious personal injury may result.

4. Lay the pruner on a flat clear area. Firmly grasp rear handle grip and throttle lockout with left hand and fully depress throttle trigger to wide open position. Rapidly pull recoil starter handle/rope (D) until engine fires.
5. After engine fires, move choke lever to "Run" position. Hold throttle trigger and throttle lockout fully depressed and pull recoil starter handle/rope (D) until engine starts and runs. Release throttle trigger and allow unit to warm up at idle for several minutes.

NOTE

If engine does not start with choke in "Run" position after 4 pulls, repeat instructions 4 and 5.

6. After engine warm up, gradually depress throttle trigger to increase engine RPM to operating speed.



STARTING WARM ENGINE

WARNING DANGER

The cutting attachment should not rotate at idle. If cutting attachment moves, readjust carburetor according to "Carburetor Adjustment" instructions in this manual or see your ECHO Dealer, otherwise serious personal injury may result.

1. Stop Switch - Start/Run. Move stop switch button (A) forward away from the STOP position.
2. Start - Pull Rope. Lay the pruner on a flat clear area and pull the recoil starter handle (D) until the engine fires.

NOTE

If engine does not start after 4 pulls, use Cold Start Procedure.

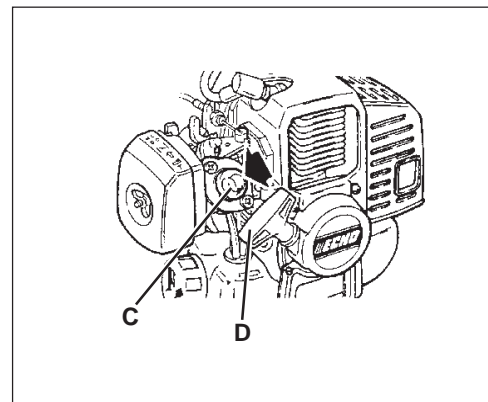
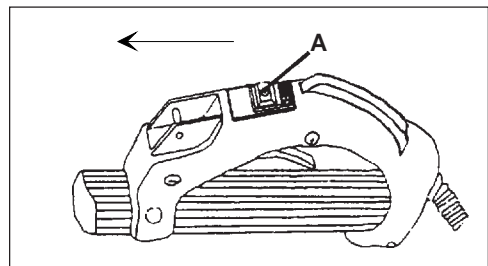

STOPPING ENGINE

1. Release Throttle. Allow engine to idle for a minute.
2. Stop Switch - Stop. Move stop switch button (A) backward to STOP position.

WARNING DANGER

If engine does not stop when stop switch is moved to STOP position, close choke - COLD START position - to stall engine. Have your ECHO dealer repair stop switch before using pruner again.

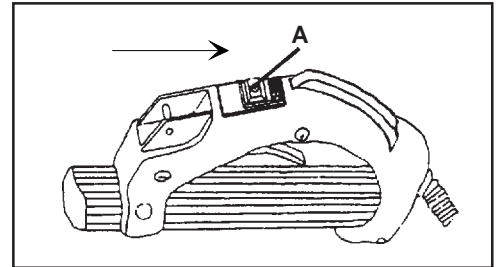

PRUNING TECHNIQUES

The Power Pruner is designed for light to medium trimming of limbs and branches up to 203 mm (8 in.) in diameter. Follow these tips for successful operation.

- Plan cut carefully. Check direction branch will fall.
- Plan retreat path from falling branch. Cut branches bounce when striking ground.
- Long branches should be removed in several pieces.
- Do not stand directly beneath branch being cut.
- When ready to cut:
Hold "cutting shoe" against branch. This will prevent whipping of the branch. DO NOT use back and forth sawing action.
- Look out for branch immediately behind the branch being cut. If saw chain hits rear branch damage to saw chain may occur.
- Accelerate to full throttle.
- Apply cutting pressure.
- Ease cutting pressure when nearing end of cut to maintain control.
- When pruning a limb 102 mm (4 in.) diameter or larger cut as follows:
 1. Under cut 1/4 limb diameter near tree trunk.
 2. Finish top cut slightly farther out on limb.
 3. Flush cut stub at trunk.
- DO NOT use for felling or bucking.

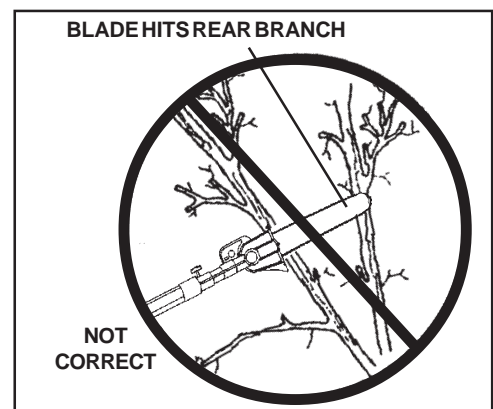
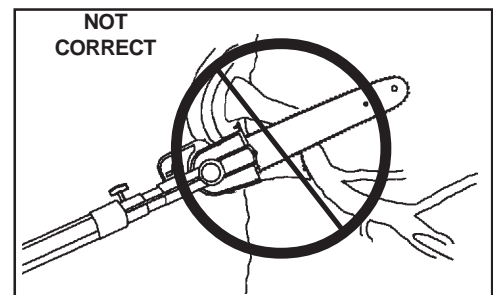
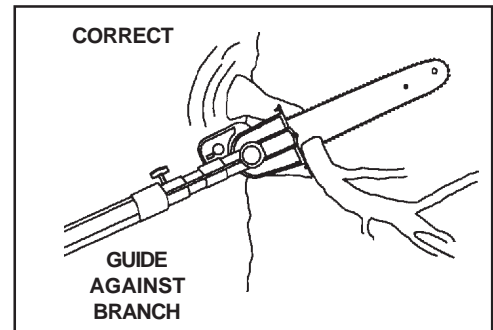

MAINTENANCE

Your ECHO Power Pruner™ is designed to provide many hours of trouble free service. Regular scheduled maintenance will help your pruner achieve that goal. If you are unsure or are not equipped with the necessary tools, you may want to take your unit to an ECHO Service Dealer for maintenance. To help you decide whether you want to DO-IT-YOURSELF or have the ECHO Dealer do it, each maintenance task has been graded. If the task is not listed, see your ECHO Service Dealer for repairs.

SKILL LEVELS

- Level 1** = Easy to do. Most required tools come with unit.
- Level 2** = Moderate difficulty. Some specialized tools may be required.
- Level 3** = Experience required. Specialized tools are required.

ECHO offers **REPOWER™** Maintenance Kits and Parts to make your maintenance job easier. Just below each task heading are listed the various part numbers required for that task. See your ECHO dealer for these parts.

MAINTENANCE INTERVALS

COMPONENT/ SYSTEM	MAINTENANCE PROCEDURE	REQ'D SKILL LEVEL	DAILY OR BEFORE USE	EVERY REFUEL	3 MONTHS OR 90 HOURS	6 MONTHS OR 270 HOURS	YEARLY 600 HOURS
Recommended Echo Dealer Maintenance Procedures							
Cylinder Exhaust Port	Inspect/Clean/Decarbon	3			I / C		
Do-It-Yourself Maintenance Procedures							
Air Filter	Inspect/Clean/Replace	1	I / C		I*		
Choke System	Inspect/Clean	2	I / C				
Fuel Filter	Inspect/Replace	1			I		I / R *
Fuel System, leaks	Inspect/Replace	1	I / R *	I	I		
Cooling System	Inspect/Clean	2	I / C				
Muffler Spark Arrestor	Inspect/Replace	2			I / R *		
Power Transmission Shaft	Inspect/Clean/Oil	2	I (1)				I
Guide Bar	Inspect/Clean/Lubricate	2	I / C	I			
Saw Chain	Inspect/Sharpen/Replace/ Lubricate	2	I / R*	I			
Recoil Starter Rope	Inspect/Clean	1	I / R*				
Spark Plug	Inspect/Clean	2			I / C	R *	
Screws/Nuts/Bolts	Inspect/Tighten/Replace	1	I / R *				

MAINTENANCE PROCEDURE LETTER CODES: I = INSPECT, R = REPLACE, C = CLEAN

IMPORTANT NOTE - Time intervals shown are maximum. Actual use and your experience will determine the frequency of required maintenance.

MAINTENANCE PROCEDURE NOTES:

* All recommendations to replace are based on the finding of damage or wear during inspection.

(1) Apply ECHO® LUBE™ every 25 hours of use.

AIR FILTER

Level 1.

Parts required: 90008REPOWER FILTER KIT

1. Close choke (Cold Start Position). This prevents dirt from entering the carburetor throat when the air filter is removed. Brush accumulated dirt from the air cleaner area.
2. Remove the air cleaner cover. Clean and inspect the element for damage. If element is fuel soaked and very dirty, replace.
3. If element can be cleaned and reused, be certain it:
 - properly fits the cavity in the air cleaner cover.
 - is installed with the original side out.

NOTE

Carburetor adjustment may be needed after air filter cleaning/replacement. See Carburetor Adjustment Section.

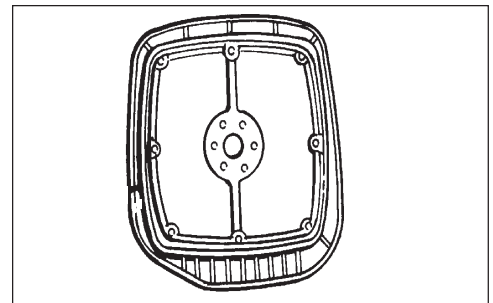
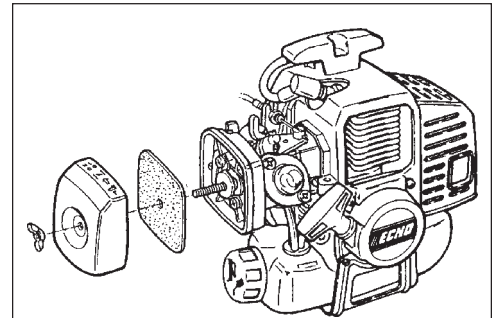
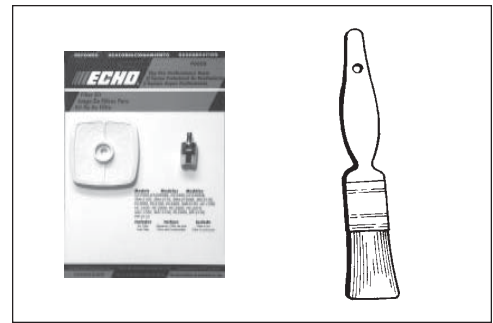

FUEL FILTER

Level 1.

Parts Required: 90008REPOWER FILTER KIT

WARNING DANGER

Fuel is **VERY** flammable. Use extreme care when mixing, storing or handling or serious personal injury may result.

1. Use a clean rag to remove loose dirt from around fuel cap and empty fuel tank.
2. Use the "fuel line hook" to pull the fuel line and filter from the tank.
3. Remove the filter from the line and install the new filter.

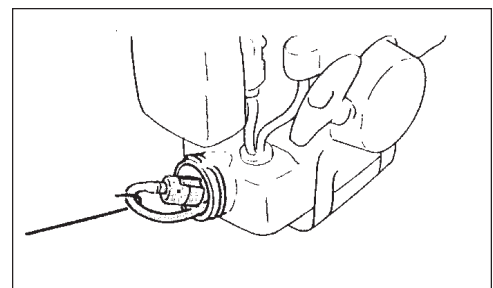
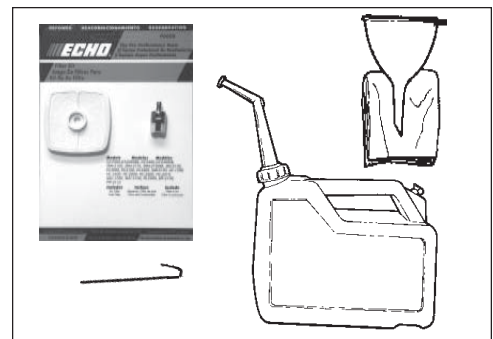

SPARK PLUG

Level 2.

Parts Required: Spark Plug, NGKBPM-7A (15901010630-PPT-2100)
NGKBPM-7Y (15901019630-PPT-2400)

1. Remove spark plug and check for fouling, worn and rounded center electrode.
2. Clean the plug or replace with a new one. DO NOT sand blast to clean. Remaining sand will damage engine.
3. Adjust spark plug gap by bending outer electrode.
4. Tighten spark plug to 145-155 kg/cm (125-135 in. lb.).

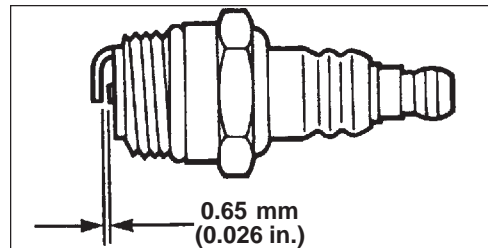
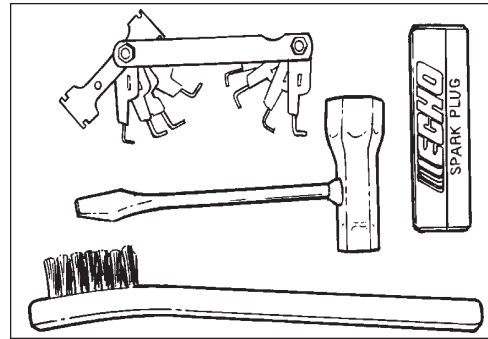

COOLING SYSTEM CLEANING

Level 3.

Parts Required: None.

IMPORTANT

To maintain proper engine operating temperatures, cooling air must pass freely through the cylinder fin area. This flow of air carries combustion heat away from the engine.

Overheating and engine seizure can occur when:

- Air intakes are blocked, preventing cooling air from reaching the cylinder.
- Dust and grass build up on the outside of the cylinder. This build up insulates the engine and prevents the heat from leaving.

Removal of cooling passage blockages or cleaning of cooling fins is considered "Normal Maintenance". Any failure attributed to lack of maintenance is not warranted.

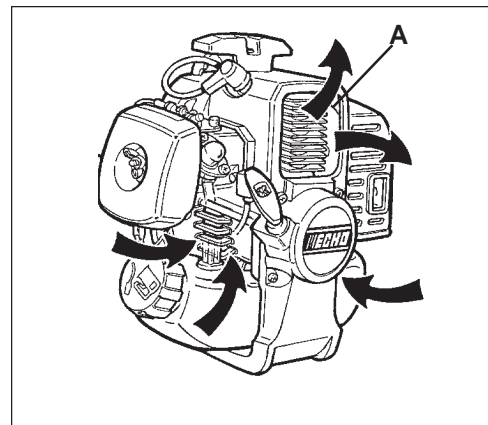
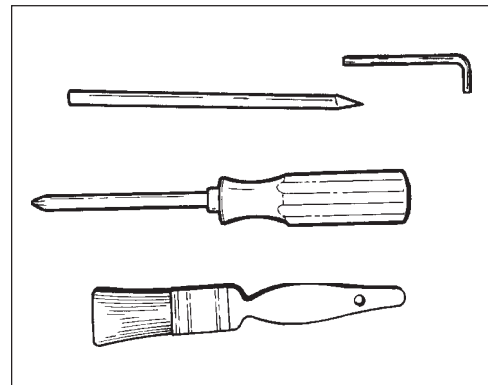

1. Remove spark plug lead from spark plug and throttle linkage end from the carburetor swivel.
2. Remove the four screws that retain the engine cover (A). Two at the top of the recoil starter, two on either side of the front. Lift the cover from the engine and lay to the front of the power pruner.

NOTE

The throttle linkage remains assembled to the engine cover and the spark plug lead and grommet remain installed.

3. Use the wooden stick or brush to remove dirt form cylinder fins.
4. Remove grass and leaves from the grid between the recoil starter and fuel tank.
5. Assemble components in reverse order.

NOTE

When installing the engine cover, be certain the tab of the metal deflector shield is in the slot of the engine cover.

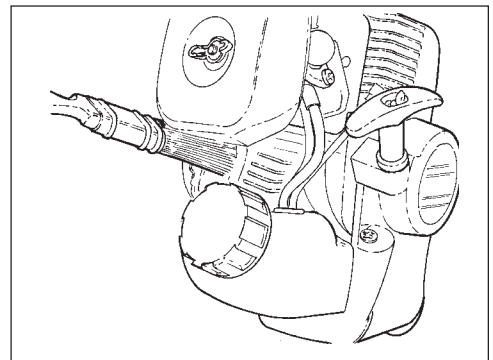
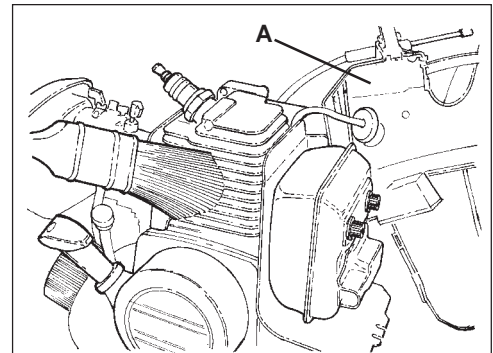

EXHAUST SYSTEM

Spark Arrestor Screen

Level 2.

Parts Required: Screen P/N 14586240630, Gasket Lid P/N 14586642031

1. Remove engine cover (A). See "Cleaning Cooling System" pages 24 & 25 for step by step instructions.
2. Place piston at Top Dead Center (TDC) to prevent carbon/dirt from entering cylinder.
3. Remove spark arrestor screen cover (B), screen holder (C), gasket (D) and screen (E) from muffler body.
4. Clean carbon deposits from screen and muffler components.
5. Replace screen if it is cracked, plugged or has holes burned through.
6. Assemble components in reverse order.

NOTE

When installing the engine cover, be certain the tab of the metal deflector shield is in the slot of the engine cover.

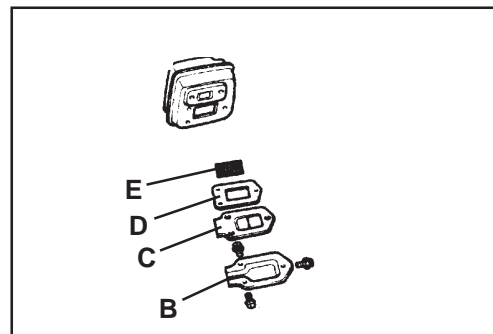
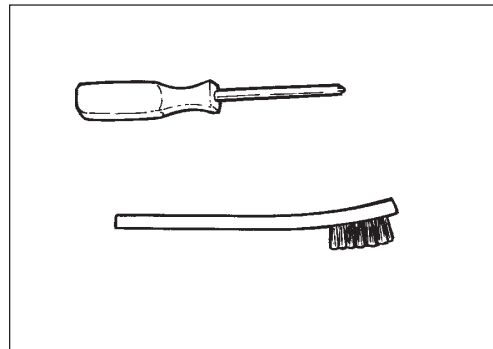

CARBURETOR ADJUSTMENT

Emission Models

Level 2.

Parts required: None.

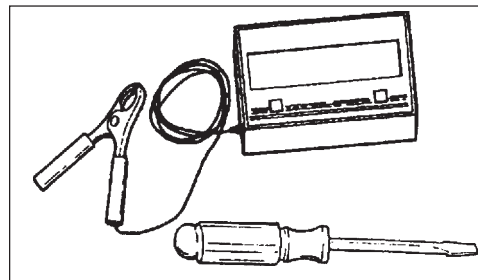

NOTE

Every unit is run at the factory and the carburetor is set in compliance with EPA Phase 1 and California Emission Regulations. In addition, the carburetor is equipped with HI (A) and LO (B) needle adjustment limiters that prevent settings outside acceptable limits.

1. Before adjusting the carburetor, clean or replace the air filter and spark arrester screen.
2. Start engine and run for several minutes to reach operating temperature.
3. Stop engine. Turn HI (A) speed needle CCW (counter clockwise) to stop. Turn LO (B) speed needle midway between full CCW and CW (clockwise) stops.
4. Idle Speed Adjustment.
-Start engine and turn idle (C) speed adjustment screw CW until the saw chain begins to turn, then turn the screw CCW until saw chain stops turning. Turn screw CCW an additional 1/4 turn.
5. Accelerate to full throttle for 2-3 seconds to clear excess fuel from engine then return to idle. Accelerate to full throttle to check for smooth transition from idle to full throttle. If engine hesitates, turn LO (B) needle CCW an additional 1/8 turn and repeat acceleration. Continue adjusting until smooth acceleration results.
6. Check HI speed RPM at W.O.T. (Wide Open Throttle). HI speed RPM should be set to specifications found on page 13 "Specifications" of this manual.
7. Check idle speed and reset if necessary. If a tachometer is available, idle speed should be set to the specification found on page 13 "Specifications" of this manual.

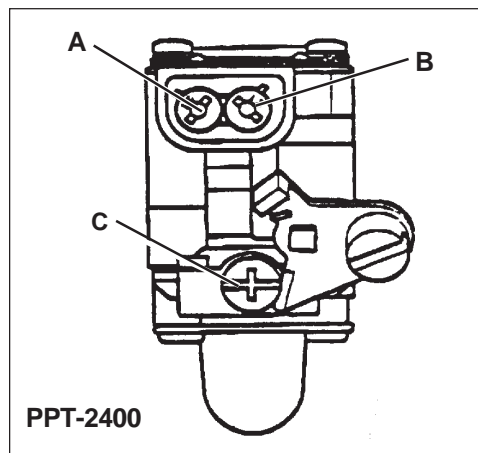
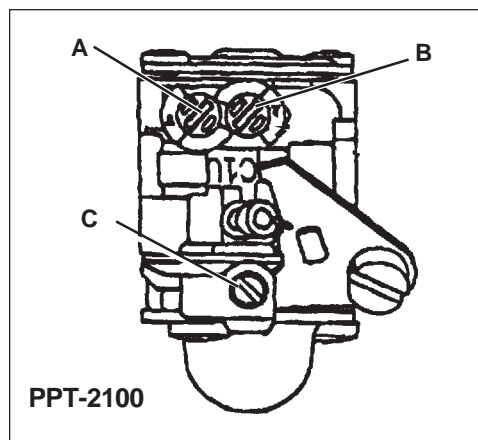

WARNING DANGER

When carburetor adjustment is completed, cutting attachment should not move at idle, otherwise serious personal injury may result.

CARBURETOR ADJUSTMENT

Non Emissions Models

NOTE

If carburetor has limiter caps follow "Carburetor Adjustment" procedures for Emission models on previous page.

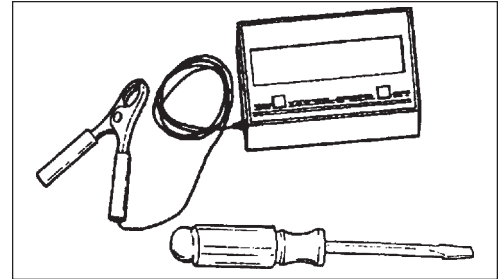

Idle Speed Adjustment

Turn "idle" speed adjustment screw (C) CW (clockwise) until saw chain begins to turn, then turn screw out CCW (counter clockwise) until saw chain stops turning. Turn screw out, CCW an additional 1/4 turn.

WARNING  DANGER

Cutting attachment must not turn when unit is idling, otherwise serious personal injury may result.

Basic Setting

1. Stop engine and turn both LO (B) and HI (A) needles in, CW until they stop and are lightly seated.

IMPORTANT

DO NOT over tighten needles. Forcing them to tighten will damage the carburetor.

2. Turn needles out CCW
 PPT-2100 LO (B) 1-3/8 turns; HI (A) 1-7/8 turns
 PPT-2400 LO (B) 2-1/2 turns; HI (A) 2-1/4 turns

Fine Tuning (Requires Accurate Tachometer)

1. Start engine and allow to warm to operating temperature (minimum 2 - 3 minutes) varying engine speed from idle to full throttle.
2. Always begin fine tuning with LO (B) needle.
 - a. Lean drop-off - With engine idling, turn LO (B) needle slowly CW (in) to lean drop-off point. RPM will increase, then abruptly drop-off. Note this position. (1)
 - b. Rich drop-off - With engine idling, slowly turn LO (B) needle CCW (out) to rich drop-off point. RPM will increase then gradually slow and drop-off. Note this position. (2)
 - c. Final setting - Set needle at mid point between lean rich drop-off points. (3)
 - d. Turn needle 1/8 turn CCW (out) making mixture slightly richer. (4)
3. HI speed adjustment.
 Adjust HI (A) needle with tachometer. Refer to Wide Open Throttle RPM settings listed in "Specifications" on page 13.
4. Check idle speed and reset if necessary. If tachometer is available, idle speed should be set to the specifications found on page 13 "Specifications" of this manual.

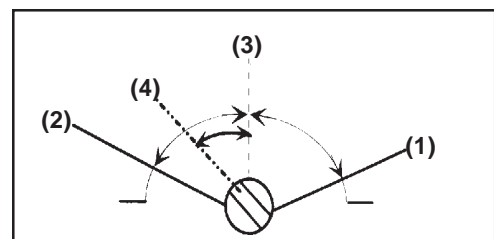
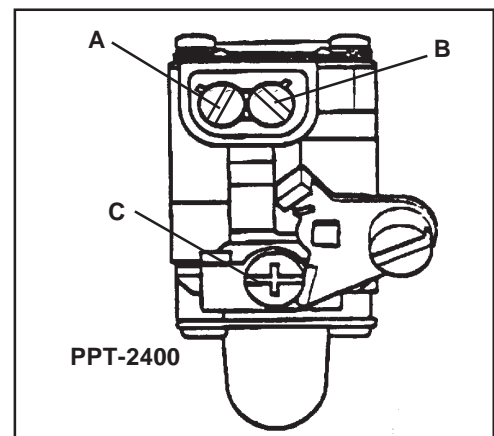
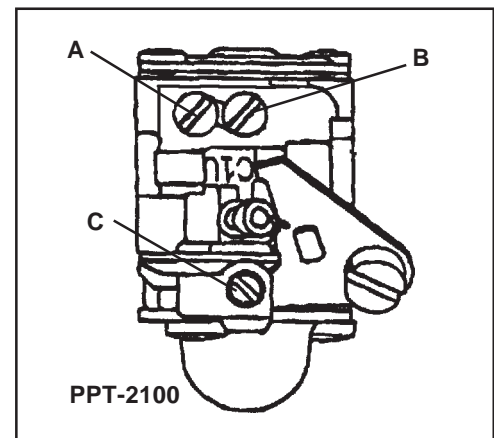

WARNING  DANGER

When carburetor adjustment is completed, cutting attachment should not move at idle, otherwise serious personal injury may result.

GUIDE BAR AND SAW CHAIN REPLACEMENT

WARNING DANGER

Never try to replace or adjust guide bar and saw chain with engine running. This saw chain is VERY sharp, wear heavy gloves to protect your hands when handling it. Wear eye protection meeting CE or ANSI Z87.1 specification.

Guide Bar Replacement / Installation

Level 3

- Loosen two (2) 11mm (7/16 in.) guide bar bolts (A) and relieve saw chain tension turning screw (B) counter clockwise.
- Remove sprocket cover.
- Free saw chain from sprocket and remove from guide bar. If guide bar is okay proceed to saw chain installation.
- Slide guide bar forward and remove from cutting attachment. Install new guide bar sliding it onto the cutting attachment as far as possible.

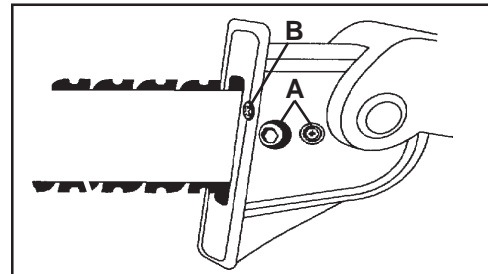

Saw Chain Installation

Level 3

- Install new saw chain onto guide bar. Make sure cutting links are faced towards the nose of the guide bar.
- Engage saw chain with sprocket.
- Replace sprocket cover.
- Follow instruction on adjusting saw chain tension page 16.

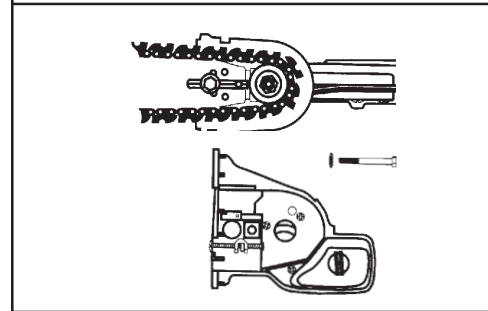

FILING SAW CHAIN

Level 3.

IMPORTANT

Dull or damaged cutters will result in poor cutting performance, increased vibration and premature saw chain failure.

WARNING DANGER

Always stop engine and wear gloves when filing saw chain, otherwise serious personal injury may result.

1. Set round file (A) in cutter at 30° angle. One fifth (1/5) of the file should be exposed above top cutter edge.
2. Keep file horizontal in cutter and file in one direction.
3. File until cutter top and side bevel edges are sharp without nicks.
4. Place depth gauge tool (B) firmly on top of cutter with .025" slot and end against front cutter raker. File cutter raker with flat file until flush with top of depth gauge.
5. Finish cutter sharpening by rounding front raker edge (C) with flat file.
6. Properly filed cutter is as shown.
7. Apply clean oil and rotate saw chain slowly to wash away filings.
8. If saw chain is coated or clogged with resin, clean in kerosene then soak in oil.

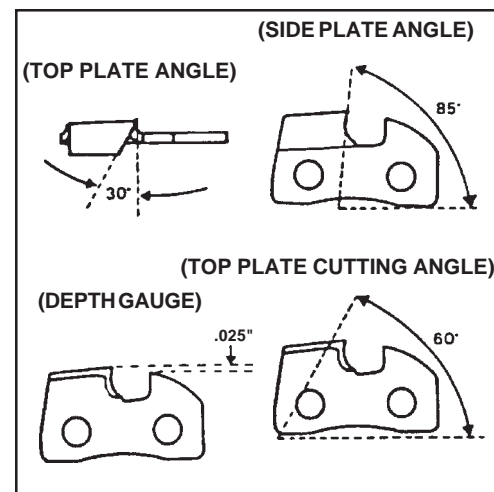
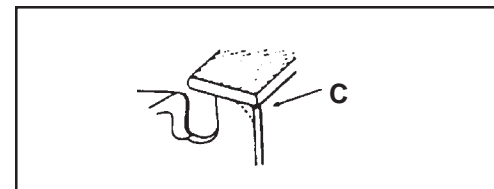
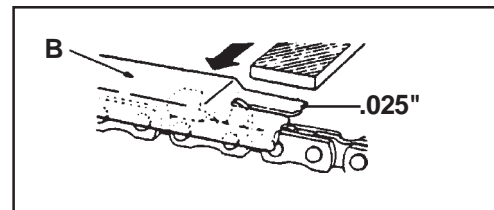
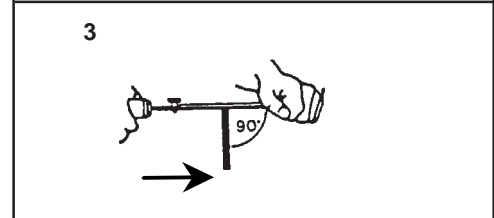
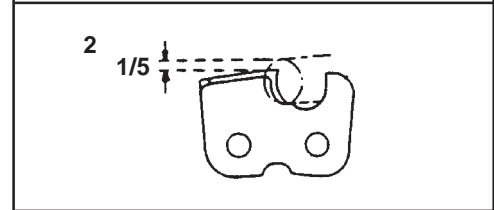
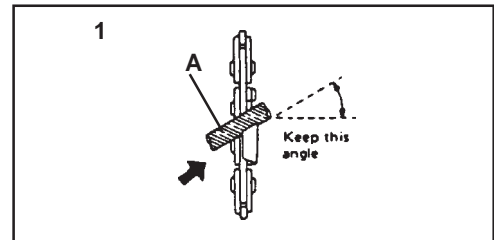

TROUBLESHOOTING

Problem		Cause	Remedy	
Engine — starts hard — does not start				
Engine Cranks	Fuel at carburetor	No fuel at carburetor	Fuel strainer clogged Fuel line clogged Carburetor	Clean Clean See your Echo dealer
	Fuel at cylinder	No fuel at cylinder	Carburetor	See your Echo dealer
		Muffler wet with fuel	Fuel mixture is too rich	Open choke Clean/replace air filter Adjust carburetor See your Echo dealer
	Spark at end of plug wire	No spark at end of plug wire	Stop switch off Electrical problem Interlock switch	Turn switch on See your Echo dealer See your Echo dealer
	Spark at plug	No spark at plug	Spark gap incorrect Covered with carbon Fouled with fuel Spark plug defective	Adjust. 0.65 mm (0.026 in.) Clean or replace Clean or replace Replace plug
Engine does not crank			Internal engine problem	See your Echo dealer
Engine runs	Dies or Accelerates poorly		Air filter dirty Fuel filter dirty Fuel vent plugged Spark plug Carburetor Cooling system plugged Exhaust port/spark arrestor screen plugged	Clean or replace Replace Replace Clean and adjust/replace Adjust Clean Clean

STORAGE

Long Term Storage (over 30 days)

Do not store your unit for a prolonged period of time (30 days or longer) without performing protective storage maintenance which includes the following:

1. Store unit in a dry, dust free place, out of the reach of children.

WARNING  **DANGER**

Do not store in enclosure where fuel fumes may accumulate or reach an open flame or spark or serious personal injury may result.

2. Move stop switch button (A) backward to STOP position.
3. Remove accumulation of grease, oil, dirt and debris from exterior of unit.
4. Perform all periodic lubrication and services that are required.
5. Tighten all the screws and nuts.
6. **Drain** the fuel tank **completely** and pull the recoil starter handle several times to remove fuel from the carburetor.
7. Remove the spark plug and pour 7 cc (1/4 oz.) [1/2 tablespoon] of fresh, clean, two-stroke engine oil into the cylinder through the spark plug hole.
 - A. Place a clean cloth over the spark plug hole.
 - B. Pull the recoil starter handle 2-3 times to distribute the oil inside the engine.
 - C. Observe the piston location through the spark plug hole. Pull the recoil handle slowly until the piston reaches the top of its travel and leave it there.
8. Install the spark plug (do not connect spark plug cable).
9. Install the guide bar cover on guide bar and saw chain.

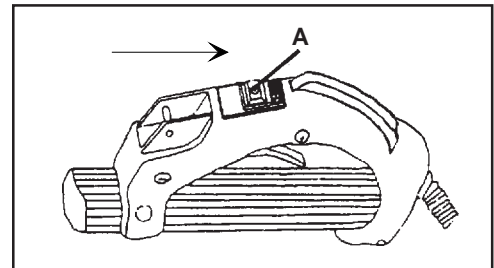

SERVICING INFORMATION

PARTS

Genuine ECHO Parts and ECHO Re Power Parts and Assemblies for your ECHO products are available only from an Authorized ECHO Dealer. When you do need to buy parts **always** have the Model Number, Type number and Serial Number of the unit with you. You can find all three numbers on the engine housing. For future reference, write them in the space provided below.

Model No. _____ Type No. _____ SN. _____

SERVICE

Service of this product during the warranty period must be performed by an Authorized ECHO Service Dealer. For the name and address of the Authorized ECHO Service Dealer nearest you, ask your retailer or call: 1-800-432-ECHO. When presenting your unit for Warranty service/repairs, proof of purchase is required.

WARRANTY CARD

This card is our means of registering all original owners of ECHO equipment. The card plus proof of purchase provides you the assurance that authorized warranty work will be done. It also provides a direct link between you and ECHO if we find it necessary to contact you.

ADDITIONAL OR REPLACEMENT MANUALS

Operator's and Parts Manuals are available for purchase from your ECHO dealer or directly from ECHO. [See ordering instructions below.]

ORDERING INSTRUCTIONS

To obtain a Parts Catalog or Operator's Manual send a check or money order for \$2.00 per Parts Catalog or \$1.50 per Operator's Manual made payable to ECHO, INCORPORATED. State on a sheet of paper the model number and serial number of the ECHO unit you have, part number of the manual (if known), your name and address and mail to address above.

Available Parts Catalog

PPT-2100 Type 1/1E S/N 503550 & Up 99922203003

PPT-2400 Type 1/1E S/N 505900 & Up 99922203004

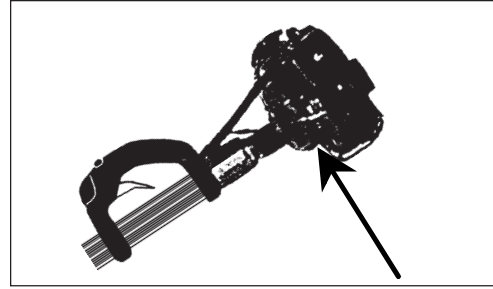

DEALER?
Call
1-800-432-ECHO

ECHO LIMITED WARRANTY REGISTRATION CARD <small>(Copy of Limited Warranty Statement included with Operator's Manual)</small>																																					
PLEASE PRINT																																					
PURCHASER'S NAME (HOMEOwner OR BUSINESS): _____																																					
ADDRESS: _____																																					
CITY: _____ STATE: _____ ZIP CODE: _____																																					
TITLE: <input type="checkbox"/> BUYER <input type="checkbox"/> OWNER <input type="checkbox"/> RENT YOURS/LEASING																																					
MAKE OF LINE: <input type="checkbox"/> ECHO <input type="checkbox"/> OTHER _____																																					
MODEL NO. (LINE & TYPE): _____																																					
SERIAL NO. (LINE & TYPE): _____																																					
DEALER'S NAME: _____																																					
CITY: _____ STATE: _____ ZIP CODE: _____																																					
YOUR PURCH: _____ SERIAL NUMBER OF ITEM: _____ CHECK PURCHASE: _____																																					
CUSTOMER SIGNATURE: _____ SELLER SIGNATURE (IF APPLICABLE): _____																																					
<table border="0"> <tr> <td colspan="2">A. PRIMARY USE OF TOOL:</td> <td colspan="2">ECHO INCORPORATED</td> </tr> <tr> <td><input type="checkbox"/> HOMEOWNER</td> <td><input type="checkbox"/> FLEECE MAINTENANCE</td> <td><input type="checkbox"/> ATLAS VIDEO CENTER</td> <td></td> </tr> <tr> <td><input type="checkbox"/> MUNICIPALITY</td> <td><input type="checkbox"/> LANDSCAPE</td> <td><input type="checkbox"/> AG EQUIPMENT</td> <td></td> </tr> <tr> <td><input type="checkbox"/> FORESTRY</td> <td><input type="checkbox"/> CONSTRUCTION</td> <td><input type="checkbox"/> OTHER</td> <td></td> </tr> </table>		A. PRIMARY USE OF TOOL:		ECHO INCORPORATED		<input type="checkbox"/> HOMEOWNER	<input type="checkbox"/> FLEECE MAINTENANCE	<input type="checkbox"/> ATLAS VIDEO CENTER		<input type="checkbox"/> MUNICIPALITY	<input type="checkbox"/> LANDSCAPE	<input type="checkbox"/> AG EQUIPMENT		<input type="checkbox"/> FORESTRY	<input type="checkbox"/> CONSTRUCTION	<input type="checkbox"/> OTHER																					
A. PRIMARY USE OF TOOL:		ECHO INCORPORATED																																			
<input type="checkbox"/> HOMEOWNER	<input type="checkbox"/> FLEECE MAINTENANCE	<input type="checkbox"/> ATLAS VIDEO CENTER																																			
<input type="checkbox"/> MUNICIPALITY	<input type="checkbox"/> LANDSCAPE	<input type="checkbox"/> AG EQUIPMENT																																			
<input type="checkbox"/> FORESTRY	<input type="checkbox"/> CONSTRUCTION	<input type="checkbox"/> OTHER																																			
<table border="0"> <tr> <td colspan="2">B. WHAT IS LIMITED YOUR DECISION TO BUY ECHO PRODUCT?</td> <td colspan="2">11. <input type="checkbox"/> SPECIAL TECHNOLOGY</td> </tr> <tr> <td><input type="checkbox"/> ECHO BRAND</td> <td><input type="checkbox"/> INCASINE AD.</td> <td><input type="checkbox"/> PRICE</td> <td></td> </tr> <tr> <td colspan="2">C. SELECT OPERATIONAL INFORMATION REQUIRED FROM PRODUCTS</td> <td colspan="2">12. <input type="checkbox"/> OTHER</td> </tr> <tr> <td><input type="checkbox"/> OPERATOR'S MANUAL</td> <td><input type="checkbox"/> DEALER</td> <td><input type="checkbox"/> USER'S MANUALS</td> <td></td> </tr> <tr> <td><input type="checkbox"/> USER'S MANUALS</td> <td><input type="checkbox"/> SAFETY MANUAL</td> <td><input type="checkbox"/> SAFETY MANUALS</td> <td></td> </tr> <tr> <td colspan="2">D. WHERE DO YOU HAVE YOUR EQUIPMENT STORED?</td> <td colspan="2">13. <input type="checkbox"/> IN GARAGE</td> </tr> <tr> <td><input type="checkbox"/> IN GARAGE</td> <td><input type="checkbox"/> IN SHED</td> <td><input type="checkbox"/> IN OTHER</td> <td></td> </tr> <tr> <td colspan="2">E. HAVE YOU REVIEWED THE SAFETY/OPERATOR'S MANUAL VIDEO OVERVIEW?</td> <td colspan="2">14. <input type="checkbox"/> YES</td> </tr> <tr> <td><input type="checkbox"/> YES</td> <td><input type="checkbox"/> NO</td> <td><input type="checkbox"/> NO</td> <td></td> </tr> </table>		B. WHAT IS LIMITED YOUR DECISION TO BUY ECHO PRODUCT?		11. <input type="checkbox"/> SPECIAL TECHNOLOGY		<input type="checkbox"/> ECHO BRAND	<input type="checkbox"/> INCASINE AD.	<input type="checkbox"/> PRICE		C. SELECT OPERATIONAL INFORMATION REQUIRED FROM PRODUCTS		12. <input type="checkbox"/> OTHER		<input type="checkbox"/> OPERATOR'S MANUAL	<input type="checkbox"/> DEALER	<input type="checkbox"/> USER'S MANUALS		<input type="checkbox"/> USER'S MANUALS	<input type="checkbox"/> SAFETY MANUAL	<input type="checkbox"/> SAFETY MANUALS		D. WHERE DO YOU HAVE YOUR EQUIPMENT STORED?		13. <input type="checkbox"/> IN GARAGE		<input type="checkbox"/> IN GARAGE	<input type="checkbox"/> IN SHED	<input type="checkbox"/> IN OTHER		E. HAVE YOU REVIEWED THE SAFETY/OPERATOR'S MANUAL VIDEO OVERVIEW?		14. <input type="checkbox"/> YES		<input type="checkbox"/> YES	<input type="checkbox"/> NO	<input type="checkbox"/> NO	
B. WHAT IS LIMITED YOUR DECISION TO BUY ECHO PRODUCT?		11. <input type="checkbox"/> SPECIAL TECHNOLOGY																																			
<input type="checkbox"/> ECHO BRAND	<input type="checkbox"/> INCASINE AD.	<input type="checkbox"/> PRICE																																			
C. SELECT OPERATIONAL INFORMATION REQUIRED FROM PRODUCTS		12. <input type="checkbox"/> OTHER																																			
<input type="checkbox"/> OPERATOR'S MANUAL	<input type="checkbox"/> DEALER	<input type="checkbox"/> USER'S MANUALS																																			
<input type="checkbox"/> USER'S MANUALS	<input type="checkbox"/> SAFETY MANUAL	<input type="checkbox"/> SAFETY MANUALS																																			
D. WHERE DO YOU HAVE YOUR EQUIPMENT STORED?		13. <input type="checkbox"/> IN GARAGE																																			
<input type="checkbox"/> IN GARAGE	<input type="checkbox"/> IN SHED	<input type="checkbox"/> IN OTHER																																			
E. HAVE YOU REVIEWED THE SAFETY/OPERATOR'S MANUAL VIDEO OVERVIEW?		14. <input type="checkbox"/> YES																																			
<input type="checkbox"/> YES	<input type="checkbox"/> NO	<input type="checkbox"/> NO																																			
<p>TO RECEIVE A COPY OF THE ECHO SAFETY VIDEO OVERVIEW ON THE REGISTRATION FORM, SEND IN FOR SHIPPING AND HANDLING TO: ECHO INCORPORATED, 400 OAKWOOD ROAD, LAKE ZURICH, IL 60047</p>																																					

ECHO Incorporated
400 Oakwood Road
Lake Zurich, IL 60047

Technical Publications Orders



ECHO, INCORPORATED

400 OAKWOOD ROAD
LAKE ZURICH, IL 60047



**SUPPLEMENT TO OPERATOR'S MANUAL
PART NUMBER 89865024661 (X7502301401)
FOR MODELS: PPT-2100 S/N 507000 & UP
PPT-2400 S/N 518000 & UP**

CUTTING ATTACHMENT INSTALLATION INSTRUCTIONS

The enclosed pages include important assembly and adjustment procedures for your new Power Pruner.

Please replace original pages 10, 13 - 16, 18, and 29 in the Operator's Manual with revised pages 10A, 13A - 16A, 18A and 29A for proper and safe operation.

ECHO CONSUMER PRODUCT SUPPORT

If you require assistance or have questions concerning the application, operation or maintenance of this product you may call the ECHO Consumer Product Support Department at 1-800-673-1558 from 8:00 am to 5:00 pm (Central Standard Time) Monday through Friday. Before calling, please know the model and serial number of your unit to help your Consumer Product Support Representative.



**ECHO, INCORPORATED
400 OAKWOOD ROAD
LAKE ZURICH, IL 60047**

SUP22203149

**99922203149
05/99**

DESCRIPTION

Due to packaging restriction the ECHO product you have purchased requires some assembly.

After opening the carton, check for damage. Immediately notify your retailer or ECHO Dealer of damaged or missing parts. Use the contents list to check for missing parts.

CONTENTS LIST

- ___ Power Head
- ___ Shaft Tube Assembly
- ___ Cutting Attachment W/ Guide Bar and Saw Chain
- ___ Plastic Bag
- ___ Operator's Manual
- ___ Safety Manual
- ___ How to Prune Manual
- ___ Warranty Registration Card
- ___ Warranty Statement
- ___ Plastic Bag
- ___ T-Wrench (combination screwdriver/spark plug socket)
- ___ 3 mm hex wrench
- ___ 8 x 10 mm Spanner
- ___ Safety Glasses
- ___ 2-Stroke Oil Bottle (2.6 oz.)
- ___ Shoulder Harness
- ___ Guide Bar Cover

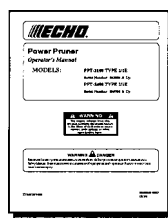
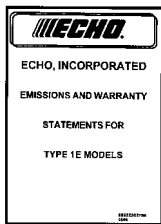

EMISSION CONTROL - Emissions Models

The emission control system for this engine is EM (Engine Modification).

IMPORTANT ENGINE INFORMATION
 ENGINE FAMILY : TEH021UB24RA
 DISPLACEMENT : 21.2cc
 THIS ENGINE MEETS U.S. EPA PHI AND
 1995 - 1999 CALIFORNIA EMISSION
 REGULATIONS FOR ULGE ENGINES.
 REFER TO OWNER'S MANUAL FOR
 MAINTENANCE SPECIFICATIONS AND
 ADJUSTMENTS.

E KIRITZ CORP.

Emission Control Label (located on Engine) (EXAMPLE ONLY, information on label varies by FAMILY).

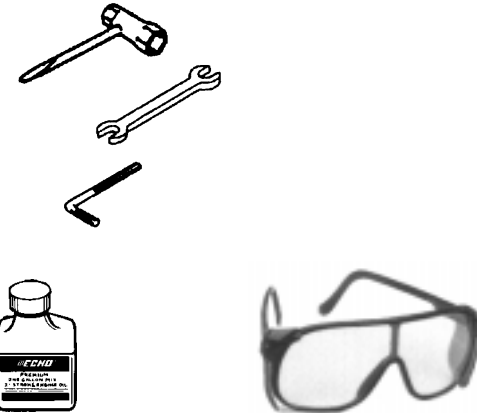

ECHO LIMITED WARRANTY REGISTRATION CARD / TARJETA DE DESCRIPCION DE GARANTIA LIMITADA	
<small>(Copy of Limited Warranty Statement included with Operator's Manual)</small>	
Please Print/Por Favor Escriba Con Letra De Imprenta	
Purchase / Nombre del Comprador o Numero/Nombre del Comprador (Duchó de Carn o Negocio)	
Address/Direccion	
City/Ciudad	Zip Code/Codigo Postal
State/Estado	Date of Purchase/Fecha de Compra
Name/Nombre Purchased	Title/Numero/Numero del Distribuidor
Model Number/Numero del Modelo	Serial No. and/or Type No. /Numero de serie Y/O numero de tipo
Customer Signature/Firma del Cliente	Dealer Signature If Applicable/Firma del Distribuidor (Si Se Aplica)
<p>Registering your purchase enables us to contact you in the unlikely event of a service update or product recall and verifies your ownership in the event of theft of loss.</p> <p style="text-align: center;">Do not write in the area.</p>	
<p>A. Primary use of tool/uso principal de la herramienta: 1.) Homeowner 2.) Landscaper 3.) Professional Dueño de casa Jardinero Profesional</p> <p>B. Safety/operational information received with product? ¿Que información de operación/seguridad recibió con el producto? 1.) Operator's Manual 2.) Safety glasses Manual del Operador Gafas de Seguridad</p> <p>C. Have you reviewed the Brush Cutter/Trimmer Safety Video overview? ¿Ha visto el video de seguridad para información general sobre el control de emisiones/seguridad? 1.) Yes/No 2.) No Disponible en any authorized Echo dealer. Ver en cualquier distribuidor autorizado de Echo.</p>	
<p>TO PURCHASE A COPY OF THE ECHO SAFETY VIDEO OVERVIEW ON THE BRUSHCUTTER/TRIMMER SAFETY MANUAL, CONTACT:</p> <p>PARA COMPRAR UNA COPIA DEL VIDEO DE INFORMACION GENERAL Y UNICAMENTE GENERAL DE ECHO SOBRE EL MANUAL DE SEGURIDAD DEL CONTROL DE EMISIONES/SEGURIDAD, PONGASE EN CONTACTO CON:</p> <p style="text-align: center;">ECHO, INCORPORATED ATTN: VIDEO OFFICE 400 CRYSTAL RD. LAKE ZURICH, IL 60057-1564</p>	

IMPORTANT This spark ignition system complies with Canadian ICES-002.

SPECIFICATIONS

MODEL	PPT-2100	PPT-2400
Length (Standard)	2.26 m (7 ft., 5 in.)	2.74 m (9 ft.)
Length (Extended)	3.41 m (11 ft., 2.25 in.)	3.91 m (2 ft., 9.75 in.)
Length w/extension	5.00 m (16 ft., 5 in.)	5.49 m (18 ft.)
Width	.22 m (8.75 in.)	
Height	.23 m (9.0 in.)	
Weight (dry)	7.4 kg (16.3 lb.)	7.7 kg (16.9 lb.)
Engine Type	Air cooled, two-stroke, single cylinder gasoline engine	
Bore	32.2 mm (1.268 in.)	34.0 mm (1.339 in.)
Stroke	26.0 mm (1.04 in.)	26.0 mm (1.04 in.)
Displacement	21.2 cc (1.29 cu. in.)	23.6 cc (1.44 cu. in.)
Exhaust System	Spark Arrestor Muffler	
Carburetor	Diaphragm, w/primer bulb	
Ignition System	CDI (capacitor discharge ignition)	
Spark Plug	NGK BPM-7A Gap 0.65 mm (0.026 in.)	NGK BPM-7Y Gap 0.65 mm (0.026 in.)
Fuel	Mixed (Gasoline and Two-stroke Oil)	
Fuel/Oil Ratio	50:1 ECHO High Performance, two-stroke air cooled engine oil	
Gasoline	89 Octane unleaded. DO NOT use fuel containing methyl alcohol, more than 10% ethyl alcohol or 15% MTBE.	
Fuel Tank Capacity	0.4 lit. (14.0 US fl. oz.)	
Starter System	Automatic Recoil Starter	
Clutch	Centrifugal Type	
Sprocket Type	6 tooth spur, 9.53 mm (3/8") pitch	
Power Transmission Shaft Assembly	Aluminum Extrusion	
Gear Case Ratio	1.5:1	
Oiling System	Automatic	
Saw Chain Oil Capacity	225 ml (7.6 oz.)	
Handle	Right hand grip w/throttle trigger and lockout	
Shoulder Harness	Standard	
Idle Speed (RPM)	2600 - 3100	
Wide Open Throttle Speed (RPM)	8000 - 9000	11,000 - 12,000
Guide Bar and Saw Chain (91 VS)	254 mm (10 in.) ; 9.53 mm (3/8") pitch	305 mm (12 in.) ; 9.53 mm (3/8") pitch

Specifications, descriptions and illustrative material in this literature are as accurate as known at the time of publication, but are subject to change without notice. Illustrations may include optional equipment and accessories, and may not include all standard equipment.

ASSEMBLY

SHAFT TUBE / POWER HEAD

Tools Required: 10x19mm (13/32x3/4in) T-wrench, 8x10mm Wrench, Hex Wrench

Parts Required: Power Head, Shaft Tube Assembly; Cutting Attachment

1. Loosen bolt (A).
2. Match square socket in engine shaft with square power transmission shaft (B) and slide together until engine rests against the machine surface of lower shaft tube housing coupler (C).
3. Rotate lower shaft tube housing to align engine and rear handle assembly in an upright position.
4. Tighten bolt (A) securely so engine will not rotate on lower shaft tube.

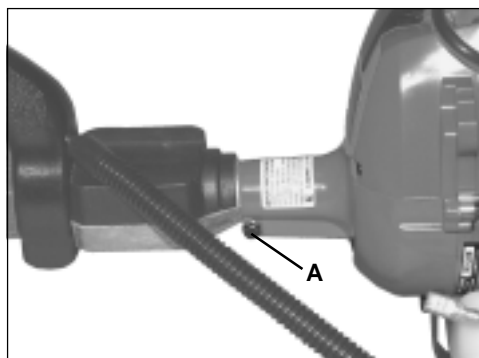
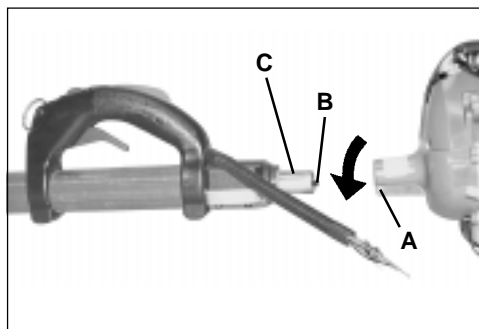
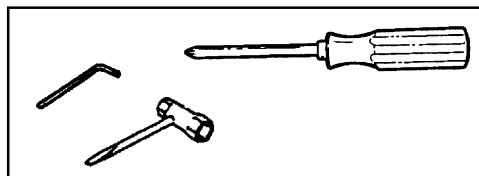

CUTTING ATTACHMENT TO SHAFT TUBE INSTALLATION

WARNING  **DANGER**

Saw Chain is sharp! Always wear gloves when handling assembly, otherwise serious personal injury may result.

1. Loosen the four (4) screws (D) and locator screw (E) on cutting attachment.

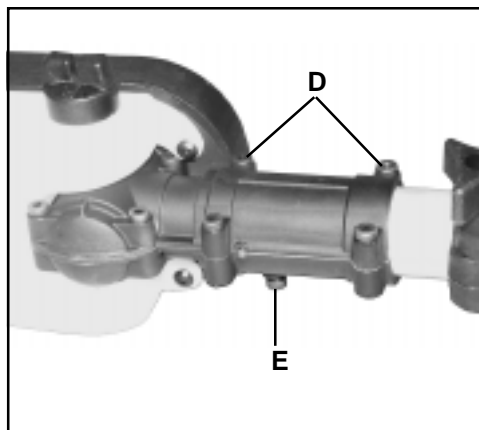

2. Loosen center clamp knob (F) turning counter clockwise.
3. Pull upper shaft tube (G) out of fiberglass lower shaft tube 127-152 mm (5-6 in.), then slide (G) back into fiberglass lower shaft tube exposing inner power transmission shaft (H). Align and join star shaped drive end of inner power transmission shaft (H) with cutting attachment shaft (I).
4. Align ridges on upper shaft tube (G) with seams in cutting attachment.
5. Slide together aligning locator screw (E) in cutting attachment with locating hole (J) in upper shaft tube.
6. Tighten locator screw (E). Tighten four (4) cutting attachment screws (D).
7. Extend upper shaft tube to desired length. Tighten center clamp knob (F) turning clockwise.

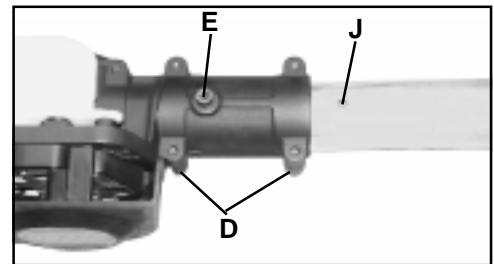
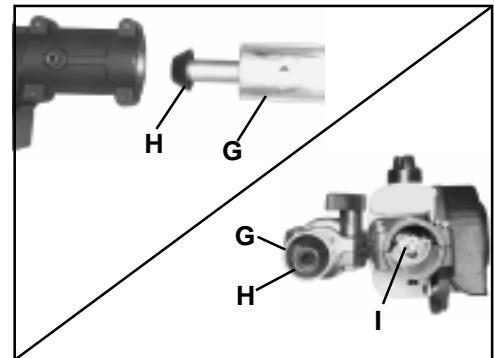
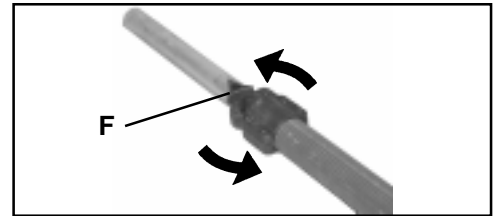

THROTTLE LINKAGE INSTALLATION

NOTE

The engine is delivered separated from shaft tube. The throttle linkage and stop switch wires are attached to the rear handle.

1. Loosen outer 10mm nut (E) on throttle linkage.
2. Insert throttle linkage in fan cover slot (A).
3. Finger tighten nut (E) and attach the inner linkage to the swivel (B) on the carburetor throttle plate.

NOTE

It is important that the head of the throttle linkage fits inside the slot well of the swivel (B).

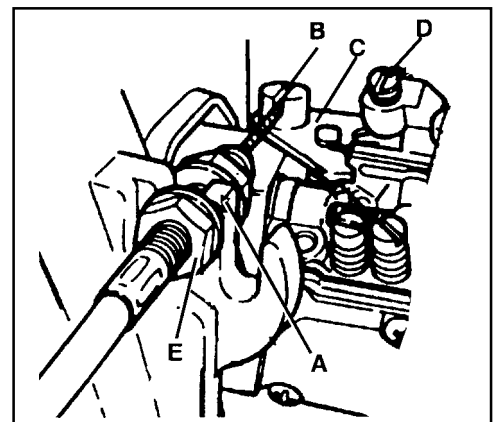

4. Tighten the 10mm linkage nuts (E).
5. Check throttle for freedom of movement and make sure it returns to idle position. If the throttle linkage does not allow the carburetor throttle plate (C) to return to idle against idle screw (D), loosen linkage nuts; turn throttle linkage nut (E) counter clockwise until throttle plate (C) rests against idle screw (D). Hold linkage nut (E) from turning and tighten other linkage nut.

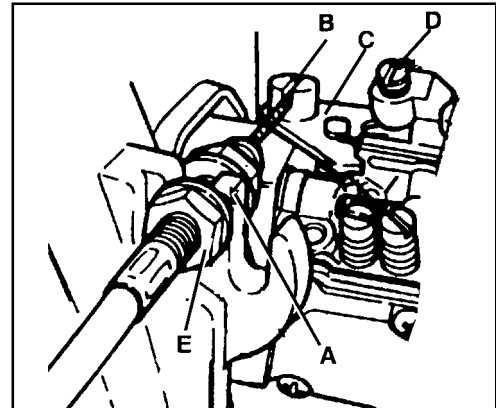

6. Connect ground wire terminal under screw (F) on fan housing.
7. Connect stop switch wire to stop wire (G) on engine.

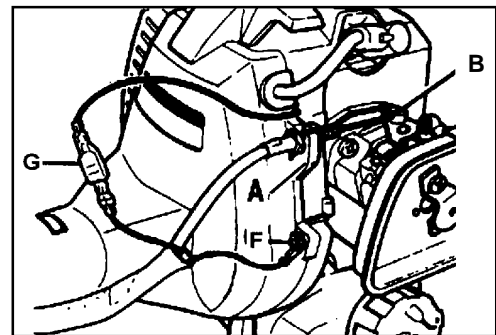

SAW CHAIN TENSION ADJUSTMENT

Tools Required: 10x19mm (13/32x3/4in.) T-wrench provided

WARNING DANGER

Always wear gloves when handling saw chain, otherwise serious personal injury may result.

To Adjust Saw Chain Tension.

1. Loosen two (2) 10 mm (13/32 in.) guide bar nuts (A) located on cutting attachment using the T-wrench provided.
2. Turn saw chain tensioner screw (B) (located next to guide bar in sprocket cover) clockwise to tighten saw chain on guide bar. Turning screw counter clockwise will loosen saw chain on guide bar.
3. Tighten guide bar nuts firmly. Move saw chain backwards on guide bar by hand. Saw chain should move freely on guide bar if it is in proper mesh with sprocket.

Keep the saw chain lubricated and properly adjusted and the guide bar nuts tightened firmly at all times. If saw chain is difficult to rotate or binds on guide bar, it is too tight.

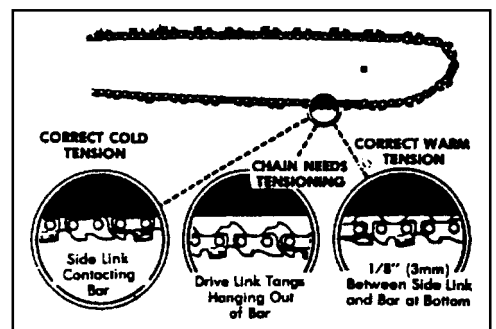
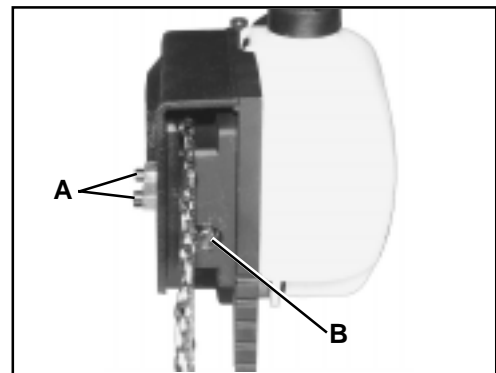

IMPORTANT

Stored fuel ages. Do not mix more fuel than you expect to use in thirty (30) days, ninety (90) days when a fuel stabilizer is added.

IMPORTANT

Stored two-stroke fuel may separate. ALWAYS shake fuel container thoroughly before each use.

S	M	T	W	T	F	S
1	2	3	4	5	6	7
8	9	10	11	12	13	14
15	16	17	18	19	20	21
22	23	24	25	26	27	28
29	30	31				

LUBRICATING THE GUIDE BAR AND SAW CHAIN

Automatic Oiling System

1. Wipe debris from around oil fill cap.
2. Remove oil fill cap and fill reservoir with a quality, low viscosity guide bar and saw chain oil.

NOTE

The discharge volume of the automatic oiler is preset to deliver 3 to 4 cc/min. at normal operating RPM. During heavy or dry cutting conditions the oil discharge volume may be adjusted to assure adequate lubrication. Refill the oil reservoir with each tank of fuel.

IMPORTANT

To prevent plastic deterioration, do not use synthetic or silicone based oil.



ADJUSTING AUTOMATIC OILER

Tools required: 10x19mm (13/32x3/4) T-Wrench provided

1. Remove two (2) 10 mm guide bar retaining nuts and sprocket cover.
2. From bottom of gear case, turn adjustment screw (A) clockwise to decrease oil volume - counter clockwise to increase oil volume.

NOTE

Very little visible oil on the saw chain will provide sufficient lubrication.

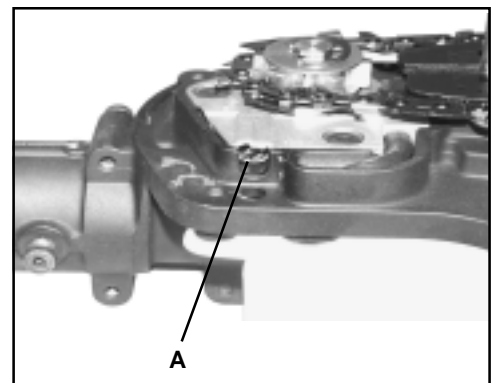

GUIDE BAR AND SAW CHAIN REPLACEMENT

WARNING DANGER

Never try to replace or adjust guide bar and saw chain with engine running. This saw chain is **VERY** sharp, wear heavy gloves to protect your hands when handling it. Wear eye protection meeting CE or ANSI Z87.1 specification.

Guide Bar Replacement / Installation

Level 3

Tools required: 10mm (13/32 in.) Socket, Screwdriver

- Loosen two (2) 10mm (13/32 in.) guide bar nuts (A) and relieve saw chain tension turning screw (B) counter clockwise.
- Remove sprocket cover.
- Free saw chain from sprocket and remove from guide bar. If guide bar is okay proceed to saw chain installation.
- Slide guide bar forward and remove from cutting attachment. Install new guide bar sliding it onto the cutting attachment as far as possible.
- Turn saw chain adjustment screw until adjusting pin (C) fits into round hole in guide bar.

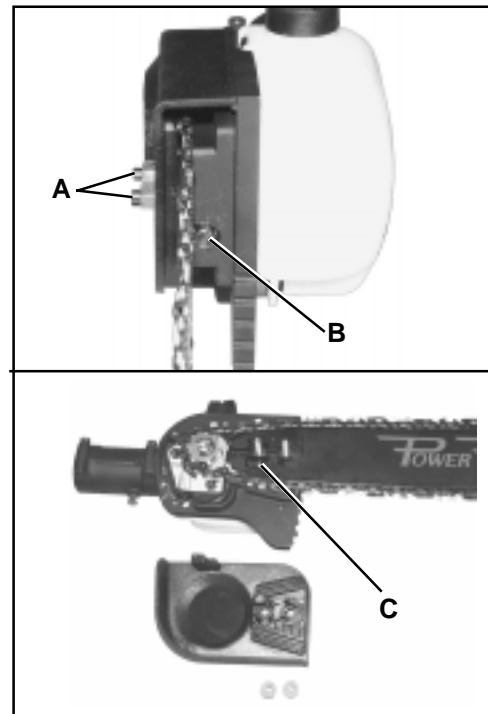

Saw Chain Installation

Level 3

- Install new saw chain onto guide bar. Make sure cutting links are faced towards the nose of the guide bar.
- Engage saw chain with sprocket.
- Replace sprocket cover and guide bar nuts.
- Follow instruction on adjusting saw chain tension page 16.

Free Manuals Download Website

<http://myh66.com>

<http://usermanuals.us>

<http://www.somanuals.com>

<http://www.4manuals.cc>

<http://www.manual-lib.com>

<http://www.404manual.com>

<http://www.luxmanual.com>

<http://aubethermostatmanual.com>

Golf course search by state

<http://golfingnear.com>

Email search by domain

<http://emailbydomain.com>

Auto manuals search

<http://auto.somanuals.com>

TV manuals search

<http://tv.somanuals.com>