



# Power Edger

## *Operator's Manual*

### MODELS

**PE-2000 Type 1/1E**

Serial Number 001001 & Up

**PE-2000 Type 2E**

Serial Number 508036 & Up

**PE-2400 Type 1/1E**

Serial Number 001001 & Up

**PE-3100 Type 1/1E**

Serial Number 001001 & Up

### WARNING DANGER



The muffler or catalytic muffler and surrounding cover may become extremely hot.

Always keep clear of exhaust and muffler area, otherwise serious personal injury may occur.



### WARNING

The engine exhaust from this product contains chemicals known to the State of California to cause cancer, birth defects or other reproductive harm.



### WARNING DANGER

Read rules for safe operation and instructions carefully. ECHO provides an Operator's Manual and a Safety Manual. Both must be read and understood for proper and safe operation.

X7502124502

89861058832  
08/01

## INTRODUCTION

Welcome to the ECHO family. This ECHO product was designed and manufactured to provide long life and on-the-job-dependability. Read and understand this manual and the SAFETY MANUAL you found in the same package. You will find both easy to use and full of helpful operations tips and SAFETY messages.

### THE OPERATOR'S MANUAL

Contains specifications and information for operation, starting, stopping, maintenance, storage and assembly specific to this product.

### THE SAFETY MANUAL

Explains possible hazards involved with the use of Edgers and the measures you should take to make their use safer.

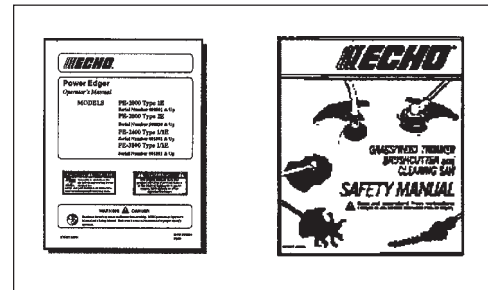

## TABLE OF CONTENTS

Introduction .....	2	- Operating Techniques .....	16
- The Operator's Manual .....	2	Maintenance .....	17
- The Safety Manual .....	2	- Skill Levels .....	17
Manual Safety Symbols and Important Information ..	3	- Maintenance Intervals .....	17
Safety .....	3	- Air filter .....	18
- Decals .....	4	- Fuel Filter .....	18
- International Symbols .....	4	- Spark Plug .....	19
Safety Instructions .....	4	- Cooling System .....	19
- Personal Condition and Safety Equipment .....	4	- Exhaust System .....	20
- Extended Operation/Extreme Conditions .....	5	- Carburetor Adjustment Emission .....	21
- Equipment .....	5	- Carburetor Adjustment Non Emission .....	22
- Safe Operation .....	6	- Lubrication .....	23
Emission Control .....	6	Troubleshooting .....	25
Description .....	7	Storage .....	26
- Contents .....	7	Servicing Information .....	28
Assembly .....	10	- Parts .....	28
- Specifications .....	10	- Service .....	28
- Drive Shaft/Power Head .....	11	- Echo Consumer Product Support .....	28
- Throttle Cable .....	11	- Warranty Card .....	28
- Loop Handle .....	12	- Additional or Replacement Manuals .....	28
Pre-Operation .....	13		
- Fuel .....	13		
Operation .....	14		
- Starting Cold Engine .....	14		
- Starting Warm Engine .....	15		
- Stopping Engine .....	15		

Specifications, descriptions, and illustrative material in this literature are as accurate as known at the time of publication, but are subject to change without notice. Illustrations may include optional equipment and accessories, and may not include all standard equipment.

## MANUAL SAFETY SYMBOLS AND IMPORTANT INFORMATION

Throughout this manual and on the product itself, you will find safety alerts and helpful information messages preceded by symbols or key words. The following is an explanation of those symbols and key words.



This symbol accompanied by the words **WARNING** and **DANGER** calls attention to an act or condition that can lead to serious personal injury to operator and bystanders



The circle with the slash symbol means whatever is shown within the circle is prohibited.



### IMPORTANT

The enclosed message provides information necessary for the protection of the unit.

### NOTE

This enclosed message provides tips for use, care and maintenance of the unit.

## SAFETY

### DECALS

Locate these safety decals on your unit. The complete unit illustration found in the "DESCRIPTION" section will help you locate them. Make sure the decals are legible and that you understand and follow the instructions on them. If a decal cannot be read, a new one can be ordered from your ECHO Dealer. See PARTS ORDERING instructions for specific information.

These decals are in English only:



P/N 89016006361

### Shaft Decal

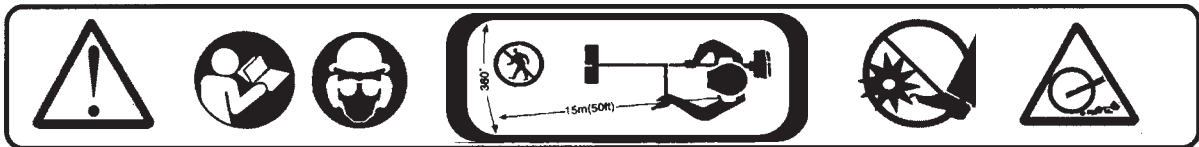

P/N 89016025560

### Guard Decal

#### - WARNING - DANGER -

• When used improperly this edger could cause serious personal injury. Read and follow all safety precautions in the owner's manual. • Never operate without eye protection. • Always inspect area for hidden or throwable objects. Never use in gravel. • Stay clear of rotating blade at all times. Keep bystanders at least 50' away. • Stop engine before adjusting cutting height or performing any service. • Never operate with unit positioned on left side of body. • Use only ECHO approved replacement blades on this unit. • Do not use edger blade on any brush cutter. • Edger attachment and blade are intended for edging only. • After replacing or servicing blade, arbors, nut and cotter pins must be assembled properly. P/N 89016052631

P/N 89016052631

## INTERNATIONAL SYMBOLS

Symbol form/ shape	Symbol description/ application	Symbol form/ shape	Symbol description/ application
	Read and understand Operator's Manual.		Fuel and oil mixture
	Wear eyes, ears and head protection		Finger Severing
	Hot Surface		Wear hand protection. Use two handed.
	Safety/Alert		DO NOT smoke near fuel.
	Avoid all power lines. This unit is not insulated against electrical current.		DO NOT allow flames or sparks near fuel.
		Keep bystanders away 15 m (50 ft.)	

Symbol form/ shape	Symbol description/ application	Symbol form/ shape	Symbol description/ application
	Keep feet away from blade		Direction of blade
	Thrown objects		Emergency stop
	Wear slip resistant foot wear.		Engine choke control.
	Primer bulb		Ignition ON/OFF
	Carburetor adjustment - High speed mixture		Carburetor adjustment - Idle speed
	Carburetor adjustment - Low speed mixture		

## SAFETY INSTRUCTIONS

### PERSONAL CONDITION AND SAFETY EQUIPMENT

## WARNING DANGER

Edger users risk injury to themselves and others if the edger is used improperly or safety precautions are not followed. Proper clothing and safety gear must be worn when operating an edger.

### *Eye Protection*

Wear eye protection that meets ANSI Z87.1 or CE requirements whenever you operate the edger.

### *Hand Protection*

Wear no-slip, heavy-duty work gloves to improve your grip on the edger handles. Gloves also reduce the transmission of machine vibration to your hands.

### *Hearing Protection*

ECHO recommends wearing hearing protection whenever unit is used.

### *Proper Clothing*

Wear snug fitting, durable clothing:

- Pants should have long legs, shirts with long sleeves.
- DONOTWEARSHORTS,
- DONOTWEARTIES,SCARVES,JEWELRY.

Wear sturdy work shoes with non-skid soles:

- DONOTWEAROPENTOEDSHOES,
- DONOTOPERATEUNITBAREFOOTED.

### *Hot Humid Weather*

Heavy protective clothing can increase operator fatigue which may lead to heat stroke. Schedule heavy work for early morning or late afternoon hours when temperatures are cooler.

## EXTENDED OPERATION/EXTREME CONDITIONS

### *Vibration and Cold*

It is believed that a condition called Raynaud's Phenomenon, which affects the fingers of certain individuals, may be brought about by exposure to vibration and cold. Exposure to vibration and cold may cause tingling and burning sensations, followed by loss of color and numbness in the fingers. The following precautions are strongly recommended because the minimum exposure which might trigger the ailment is unknown.

- Keep your body warm, especially the head, neck, feet, ankles, hands, and wrists.
- Maintain good blood circulation by performing vigorous arm exercises during frequent work breaks, and also by not smoking.
- Limit the hours of operation. Try to fill each day with jobs where operating the edger or other hand-held power equipment is not required.
- If you experience discomfort, redness, and swelling of the fingers, followed by whitening and loss of feeling, consult your physician before further exposing yourself to cold and vibration.

### *Repetitive Stress Injuries*

It is believed that overusing the muscles and tendons of the fingers, hands, arms, and shoulders may cause soreness, swelling, numbness, weakness, and extreme pain in those areas. Certain repetitive hand activities may put you at a high risk for developing a Repetitive Stress Injury (RSI). An extreme RSI condition is Carpal Tunnel Syndrome (CTS), which could occur when your wrist swells and squeezes a vital nerve that runs through the area. Some believe that prolonged exposure to vibration may contribute to CTS. CTS can cause severe pain for months or even years.

To reduce the risk of RSI/CTS, do the following:

- Avoid using your wrist in a bent, extended or twisted position. Instead try to maintain a straight wrist position. Also, when grasping, use your whole hand, not just the thumb and index finger.
- Take periodic breaks to minimize repetition and rest your hands.
- Reduce the speed and force with which you do the repetitive movement.
- Do exercises to strengthen the hand and arm muscles.
- Immediately stop using all power equipment and consult a doctor if you feel tingling, numbness or pain in the fingers, hands, wrists, or arms. The sooner RSI/CTS is diagnosed, the more likely permanent nerve and muscle damage can be prevented.

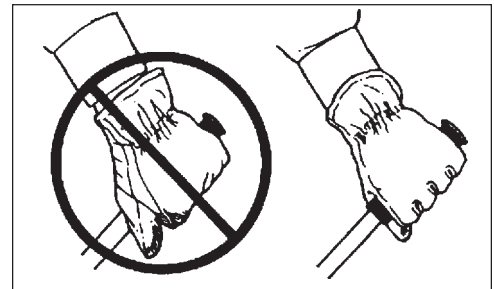

## EQUIPMENT

- Check unit for loose/missing nuts, bolts and screws. Tighten and/or replace as needed.
- Inspect fuel lines, tank and area around carburetor for fuel leaks. DO NOT operate unit if leaks are found.
- Inspect shield for damage and is **securely** in place. Replace if shield is damaged or missing.
- Check that the cutting attachment is firmly attached and in safe operating condition.
- Check that front handle is adjusted for safe, comfortable operation. See Assembly for proper adjustment.
- Keep exhaust area clear of flammable debris. Avoid contact during and immediately after operation.

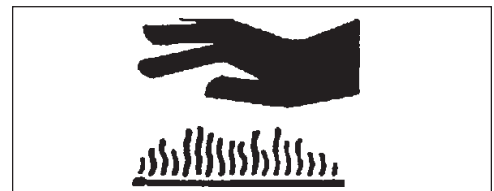

## SAFE OPERATION

### WARNING DANGER

Do not operate this product indoors or in inadequately ventilated areas. Engine exhaust contains poisonous emissions and can cause serious injury or death.

- Provide all operators of this equipment with the Operator's Manual and Safety Manual for instructions on safe operation.

#### Keep A Firm Grip

- Hold the left and right handles with both hands, with thumbs and fingers tightly encircling the handles

#### Keep A Solid Stance

- Maintain footing and balance at all times. Do not stand on slippery, uneven or unstable surfaces. Do not work in odd positions or on ladders. Do not over-reach.



## EMISSION CONTROL

The emission control system for this engine is EM (Engine Modification).

**IMPORTANT ENGINE INFORMATION**  
ENGINE FAMILY: TEH024UB24RC  
DISPLACEMENT: 23.6 CC  
THIS ENGINE MEETS U.S. EPA PH1 AND 1996 -  
1998 CALIFORNIA EMISSION REGULATIONS  
FOR ULGE ENGINES. REFER TO OWNER'S  
MANUAL FOR MAINTENANCE SPECIFICATIONS  
AND ADJUSTMENTS.



**KIORTZ CORP.** 

An Emission Control Label is located on the engine. (This is an EXAMPLE ONLY, information on label varies by engine family).

## DESCRIPTION

The ECHO product you purchased has been factory pre-assembled for your convenience. Due to packaging restrictions, shield installation and positioning of the front handle are necessary.

After opening the carton, check for damage. Immediately notify your retailer or ECHO Dealer of damaged or missing parts. Use the contents list to check for missing parts.

## CONTENTS

- \_\_1, Edger Assembly
- \_\_1, Power Head
- \_\_1, Drive Shaft Assembly
- \_\_1, Plastic Bag (Co-Pack)
- \_\_1, Operators Manual
- \_\_1, Safety Manual
- \_\_1, Warranty Registration Card
- \_\_1, ECHO Emissions and Warranty Statement
- \_\_1, 50:1 1 Gal. ECHO Oil Mix
- \_\_1, Front Handle
- \_\_2, bolt 5x40mm
- \_\_2, nut 5
- \_\_1, split pin
- \_\_1, Srench (Combination Spark Plug Socket/Screwdriver
- \_\_1, Locking Tool
- \_\_1, 10 mm Spanner Wrench
- \_\_1, Safety Glasses

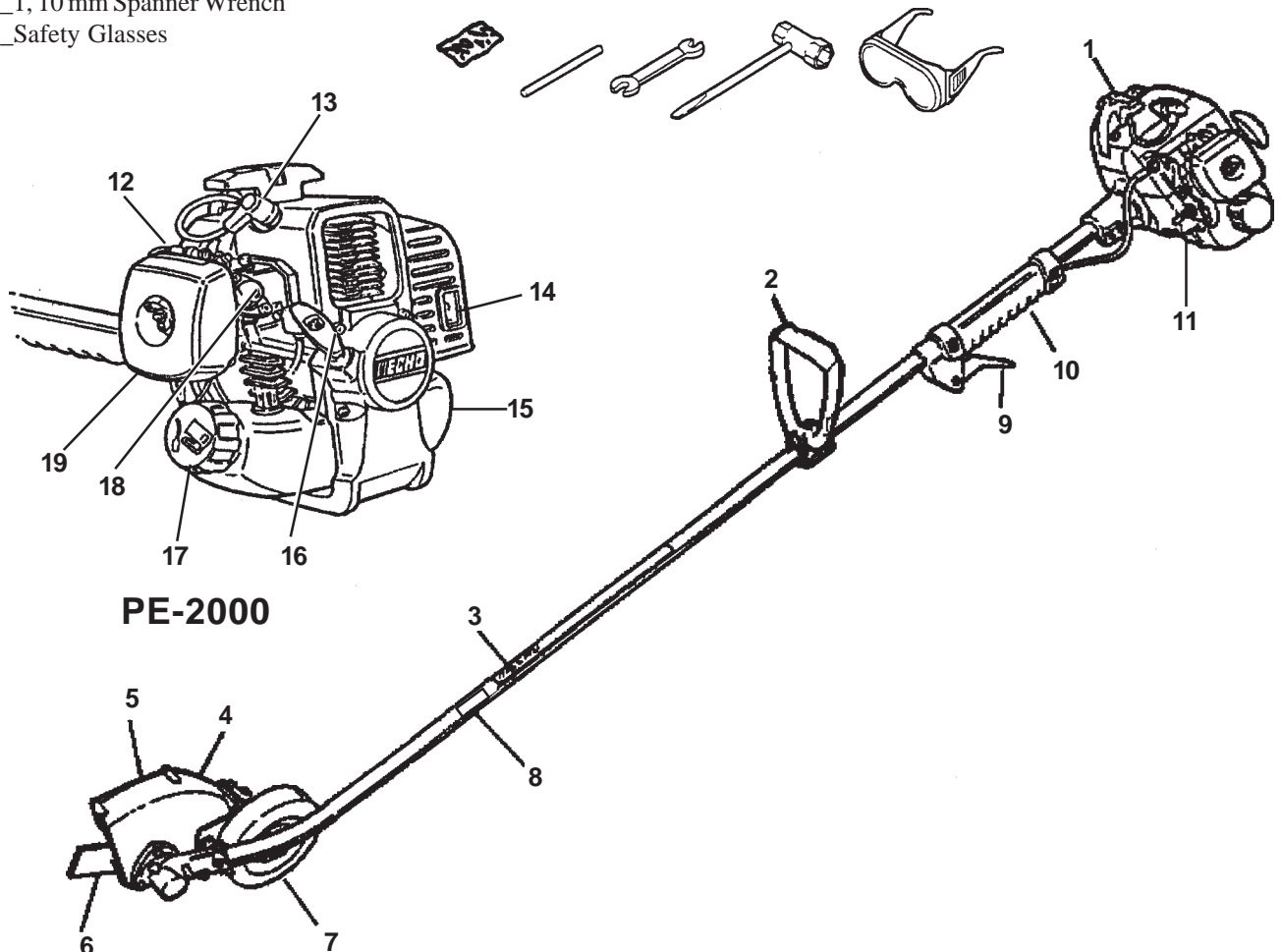
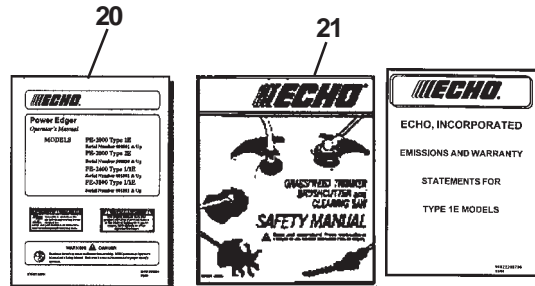

## CONTENTS

- 1, Edger Assembly
- 1, Power Head
- 1, Drive Shaft Assembly
- 1, Plastic Bag (Co-Pack)
- 1, Operators Manual
- 1, Safety Manual
- 1, Warranty Registration Card
- 1, ECHO Emissions and Warranty Statement
- 1,50:1 1 Gal. ECHO Oil Mix
- 1, Front Handle
- 4, 5X35 mm screws
- 4, 5 mm nuts
- 1, Srench (Combination Spark Plug Socket/Screwdriver)
- 1, split pin
- 1, 3 mm Hexagon Wrench
- 1, Locking Tool
- 1, 10 mm Spanner Wrench
- Safety Glasses

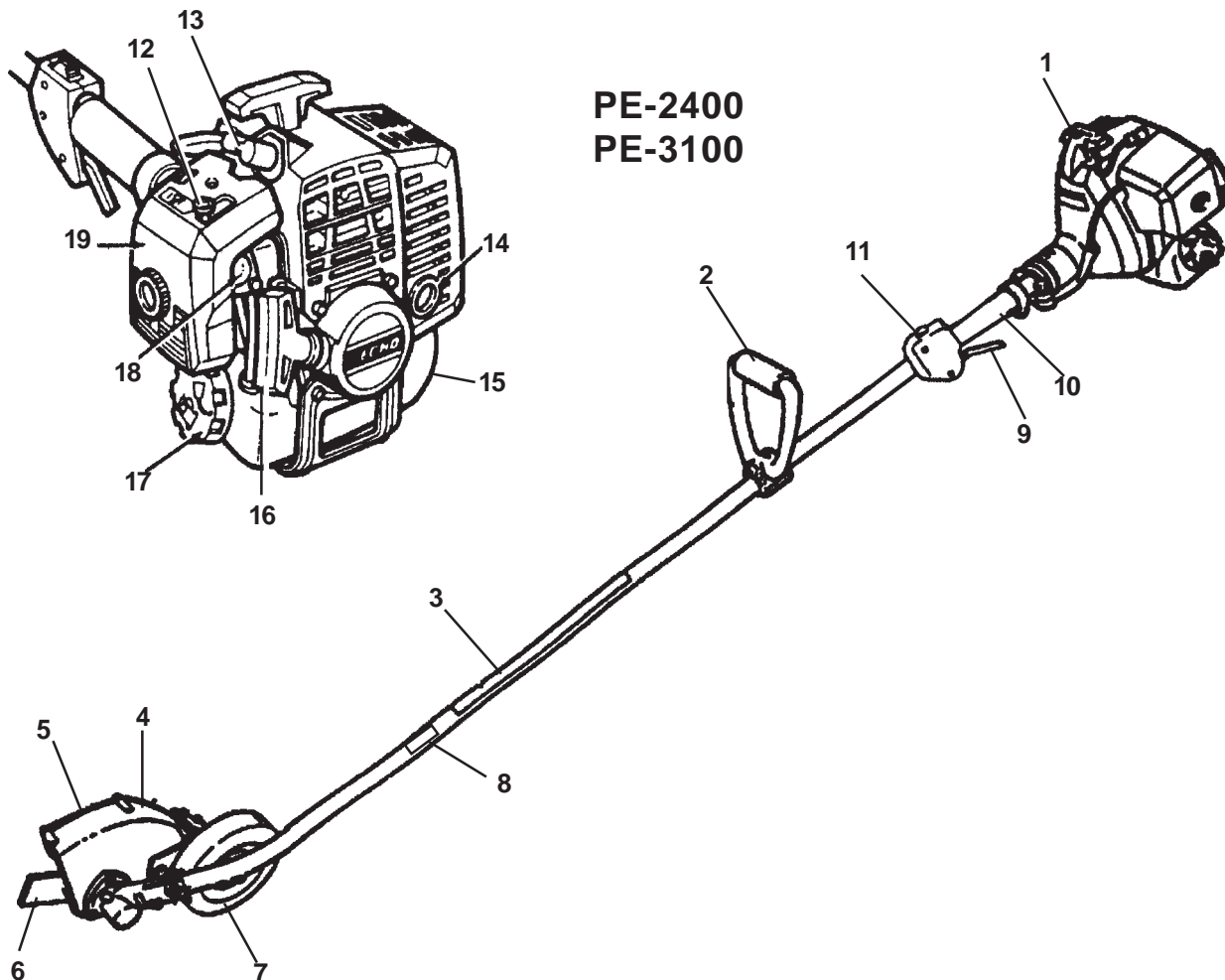
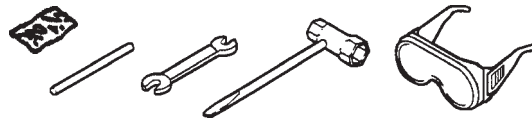
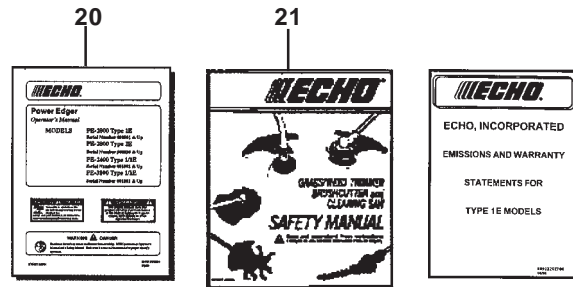



1. **TOP GUARD** - Protects arm from the hot engine.
2. **FRONT HANDLE** - The front handle can be repositioned for comfortable operation by loosening the screws and moving the handle.
3. **SHAFTDECAL** (See page 3)
4. **GUARDDECAL** (See page 3)
5. **DEBRIS SHIELD/FLAP** - Mounted over the cutting attachment. Helps protect operator by deflecting debris produced during the edging operation.
6. **BLADE** - Rotates to provide cutting action.
7. **WHEEL** - Adjustable up/down, sets depth of blade.
8. **DRIVE SHAFT ASSEMBLY** - Contains a specially designed liner and the flexible drive shaft.
9. **THROTTLE TRIGGER** - Spring loaded to return to idle when released. When accelerating, press trigger gradually for best operating technique.
10. **GRIP** - Rear (right hand) handle.
11. **STOPSWITCH** -  
PE-2000 - "Toggle Switch" mounted on the engine. Move switch UP to RUN, DOWN to STOP.  
PE-2400/3100 - "Slide Switch" mounted on top of the throttle Trigger Housing. Move switch FORWARD to RUN, BACK to STOP.
12. **CHOKE** - The choke control is located on the top of the air filter case (PE-2400, 3100), or on the side of the air filter case (PE-2000).  
PE-2000 - Move lever to "COLD START" to close choke for cold starting. Move lever to "RUN" position to open choke.  
PE-2400/3100 - Pull choke knob up to close choke for cold starting. Push knob down to "RUN" position to open choke.
13. **SPARK PLUG** - Provides spark to ignite fuel mixture.
14. **MUFFLER/SPARK ARRESTOR** - The spark arrestor muffler controls the exhaust noise and prevents hot, glowing particles of carbon from leaving the muffler.
15. **FUEL TANK** - Contains fuel and fuel filter.
16. **RECOIL STARTER HANDLE** - Pull recoil handle slowly until starter engages, then quickly and firmly. **DO NOT** let handle snap back or damage to unit will occur.
17. **FUEL TANK CAP** - Cover and seals fuel tank.
18. **PRIMER BULB** - Pumping primer bulb before starting engine draws fresh fuel from the fuel tank priming the carburetor for starting. Pump primer bulb until fuel is visible and flows freely in the clear fuel tank return line. Pump bulb an additional 4 or 5 times.
19. **AIR CLEANER** - Contains replaceable felt element.
20. **OPERATORS MANUAL** - Read and understand this manual before assembly or operation. Keep manual in a safe location for future reference, i.e., operation, maintenance, storage and specifications.
21. **SAFETY MANUAL** - Read and understand this manual before assembly or operation, and keep in a safe place for future reference to learn proper, safe operating techniques.

## ASSEMBLY SPECIFICATIONS

MODEL	PE-2000 1E/2E	PE-2400 1/E	PE-3100 1/E
Length	1753 mm (69.0 in.)	1770 mm (69.7 in.)	1795 mm (70.7 in.)
Width	330 mm (13.0 in.)	330 mm (13.0 in.)	330 mm (13.0 in.)
Height	300 mm (11.8 in.)	300 mm (11.8 in.)	300 mm (11.8 in.)
Weight (dry w/cutter head)	5.5 kg (12.2 lb.)	5.9 kg (13.0 lb.)	7.1 kg (15.6 lb.)
Engine Type	Air cooled, two-stroke, single cylinder gasoline engine		
Bore	32.2 mm (1.268 in.)	34.0 mm (1.34 in.)	36.0 mm (1.42 in.)
Stroke	26.0 mm (1.024 in.)	26.0 mm (1.024 in.)	30.0 mm (1.18 in.)
Displacement	21.2 cc (1.29 cu. in.)	23.6 cc (1.44 cu. in.)	30.5 cc (1.89 cu. in.)
Exhaust	*Spark Arrestor Muffler		
Carburetor diaphragm w/purge	Zama model C1U	Walbro model WT	Walbro model WT
Ignition System	CDI (capacitor discharge ignition)		
Spark Plug	NGK BPM-7A, 0.65mm (0.026 in.)	NGK BPM-7Y or Champion CJ-7Y 0.65mm (0.026 in.)	
Fuel	Mixed (Gasoline and Two-stroke Oil)		
Fuel/Oil Ratio	50:1 ECHO High Performance, two-stroke air cooled engine oil		
Gasoline	89 Octane unleaded. DO NOT use fuel containing methyl alcohol, more than 10% ethyl alcohol or 15% MTBE.		
Oil	50:1 ECHO High Performance, two-stroke air cooled engine oil		
Fuel Tank Capacity	0.4 lit. (14.0 US fl. oz.)	0.4 lit. (14.0 US fl. oz.)	0.8 lit. (27.1 US fl. oz.)
Starter System	Automatic Rewind Starter		
Clutch	Centrifugal Type		
Drive Shaft	1/4 in. flexible shaft		
Rotation Direction	Clockwise viewed from side		
Edger Head	Metal blade		
Blade Length	203.2 mm (8.0 in.)		
Blade Width	50.8 mm (2 in.)		
Blade Thickness	2.5 mm (0.9 in.)		4.5 mm (0.180 in.)
Handle	Left - D-loop, Right -Grip		
Vibration Reduction	Rubber Cushion		
Idle Speed	2500 - 3100 RPM	2500 - 3100 RPM	2400 - 3000 RPM
Wide Open Throttle Speed	9000 - 10000 RPM	10000 - 11000 RPM	9500 - 11000 RPM

## DRIVE SHAFT/POWER HEAD

*Tools Required:* 8mm x 10mm Open End Wrench (PE-2000, PE-2400),  
4mm Hex Wrench (PE-3100)

1. Stand engine on a level surface.
- 2a. (PE-2000/2400) Loosen the two bolts (A) at drive shaft end of engine.
- 2b. (PE-3100) Loosen two bolts (A) at drive shaft end of engine and remove center drive shaft location bolt (B).
3. Carefully fit drive shaft assembly to engine, making sure that inner drive shaft engages into clutch mount.

### NOTE

The line on the drive shaft housing must be in contact with the engine (arrow  $\Delta$  on drive shaft indicates line).

- 4a. (PE-2000/2400) Rotate the drive shaft housing until edger housing is in line with the engine.
- 4b. (PE-3100) Rotate drive shaft housing until locating hole lines up with center location hole in clamp and install center bolt (B).
5. Tighten bolts (A).

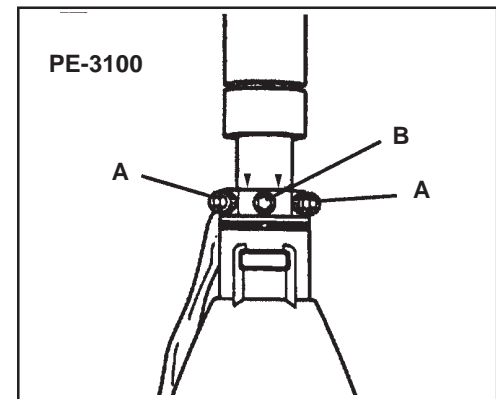
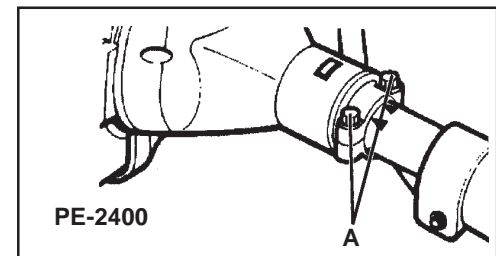
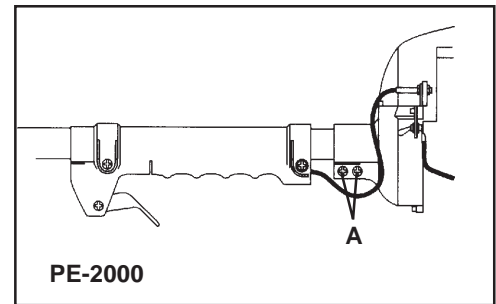

## THROTTLE LINKAGE

*Tools Required:* 8mm x 10mm Open End Wrench (All Models), 3mm Wrench (PE-2400)

1. Close choke and remove air filter cover.
2. Loosen nut (A) and place threaded end of throttle linkage in bracket slot. Finger tighten nut (A). Place inner cable in slot of carburetor (B).
3. Check throttle action, for freedom of movement and that the inner throttle linkage allows the carburetor throttle plate (E) to return to idle stop. Adjust cable nut counter clockwise to increase inner throttle linkage length and allow throttle plate to rest against stop.
4. Tighten nut (A).

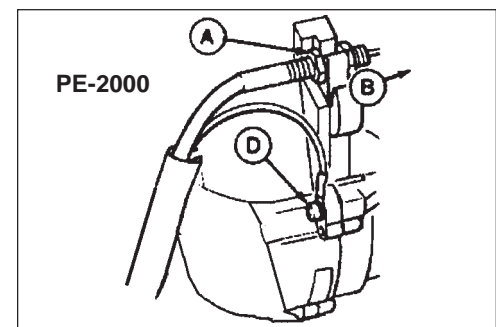

**NOTE**

Steps 5, 6 & 7 required for PE-2400 and PE-3100 only.

5. Connect ignition leads (C).
6. (PE-2400) Secure ground lead under screw (D) on housing.
7. Install air filter and cover.

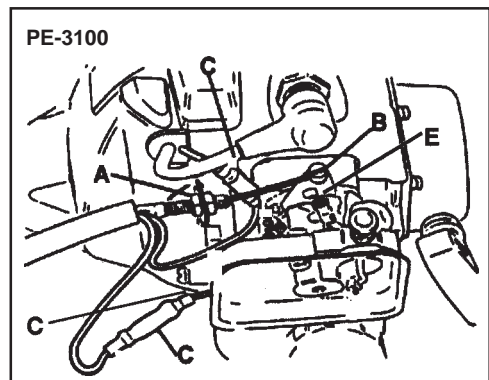
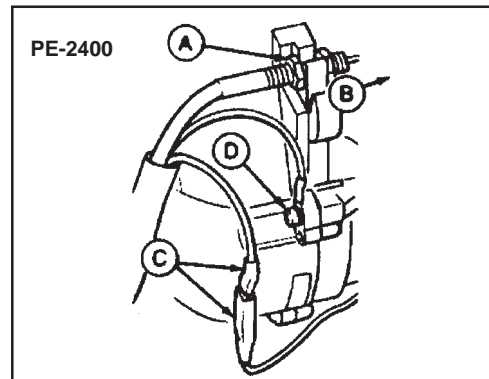

## FRONT HANDLE

*Tools Required: Cross-Head Screwdriver*

**(PE-2000)**

1. Assemble loop handle (A) and bottom bracket (B) loosely using screws (C) and nuts (D) to loop handle collar (E), located on drive shaft (F).
2. Position handle in comfortable operating position and tighten screws (C).

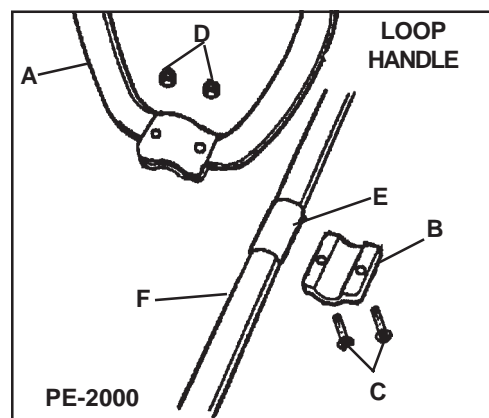

**(PE-2400, 3100)**

1. Assemble front handle and bracket loosely to drive shaft.
2. Position front handle in comfortable operating position and tighten screws.

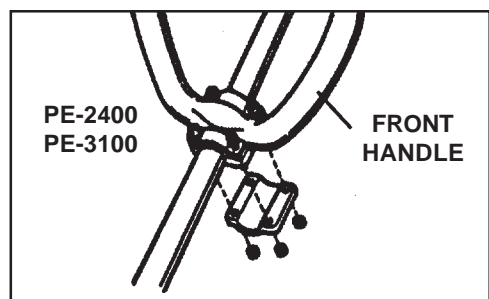

## PRE-OPERATION

### FUEL

#### *Fuel Requirements*

**Gasoline** - Use 89 Octane [ (R+M) ÷ 2 ] gasoline known to be good quality. Gasoline may contain up to 10% Ethanol (grain alcohol) or 15% MTBE (methyl tertiary-butyl ether). Gasoline containing methanol (wood alcohol) is **NOT** approved.

**Two-Stroke Oil - Two Stroke Oil** - A two-stroke engine oil meeting ISO-L-EGD (ISO/CD 13738) and J.A.S.O. FC Standards, must be used. Echo brand Premium 50:1 oil meets these standards. Engine problems due to inadequate lubrication caused by failure to use an ISO-L-EGD and J.A.S.O. FC certified oil, such as Echo Premium 50:1 Two-stroke Oil, will void the two-stroke engine warranty. (Emission related parts only are covered for two years, regardless of two-stroke oil used, per the statement listed in the EPA Phase I/California Emission Defect Warranty Explanation.)

#### **IMPORTANT**

Echo Premium 2-Stroke Oil may be mixed at 50:1 ratio for application in all Echo engines sold in the past regardless of ratio specified in those manuals.

#### Mixing Instructions

1. Fill an approved fuel container with half of the required amount of gasoline.
2. Add 2-stroke oil to gasoline.
3. Close container and shake to mix oil with gasoline.
4. Add remaining gasoline and remix.
5. Install fuel container cap and wipe any spilled fuel from container and surrounding area.

#### *Handling Fuel*

### **WARNING** **DANGER**

Fuel is **VERY** flammable. Use extreme care when mixing, storing or handling, or serious personal injury may result.

- Use an approved fuel container.
- **DO NOT** smoke near fuel.
- **DO NOT** allow flames or sparks near fuel.
- Fuel tanks/cans may be under pressure. Always loosen fuel caps slowly allowing pressure to equalize.
- **NEVER** refuel a unit when the engine is **HOT!**
- **NEVER** refuel a unit with the engine running.
- **DO NOT** fill fuel tanks indoors. **ALWAYS** fill fuel tanks outdoors over bare ground.
- Securely tighten fuel cap after refueling.
- Inspect for fuel leakage. If fuel leakage is found, do not start or operate unit until leakage is repaired.

#### **IMPORTANT**

Spilled fuel is a leading cause of hydrocarbon emissions. Some states may require the use of automatic fuel shut-off containers to reduce fuel spillage. Contact your ECHO dealer for ordering information.

#### *After refueling*

- Wipe any spilled fuel from the unit.
- Move at least 3 m (10 ft.) from refueling location before starting the engine.

#### *After use*

- **DO NOT** store a unit with fuel in its tank. Leaks can occur. Return unused fuel to an approved fuel storage container.

#### *Storage*

Fuel storage laws vary by locality. Contact your local government for the laws affecting your area. As a precaution, store fuel in an approved, air tight container. Store in a well ventilated, unoccupied building, away from sparks and flames. Do not store fuel longer than 30 days.

#### **IMPORTANT**

Stored fuel ages. Do not mix more fuel than you expect to use in thirty (30) days, ninety (90) days when a fuel stabilizer is added.

#### **IMPORTANT**

Stored two-stroke fuel may separate. **ALWAYS** shake fuel container thoroughly before each use.

## OPERATION

### STARTING COLD ENGINE

#### NOTE

- Check unit for loose nuts, bolts and screws before starting.
- Always clear work area of debris before starting operation.
- Always position the unit firmly on the ground before starting.
- When pulling recoil starter rope, use short pulls, 1/2 to 2/3 of rope length.
- Do not allow the recoil starter handle to snap back against the housing.
- Always hold the unit firmly.

#### WARNING DANGER

When engine starts, the blade may rotate, even with throttle trigger in idle (Release) position.

1. *Stop Switch*  
Move stop switch button (A) away from the STOP position.
2. *Choke*  
Move choke (B) to "Cold Start" position.
3. *Primer Bulb*  
Pump primer bulb (C) until fuel is visible in the "Clear" fuel return line. Pump bulb an additional 4 or 5 times.

#### WARNING DANGER

Inspect starting area for hazards such as rocks, glass, debris etc. which could be contacted by the cutting attachment when starting. Keep helpers and bystanders at least 15 m (50 ft.) from starting area, otherwise serious personal injury may result.

4. *Recoil Starter*  
Lay trimmer on a flat, clear area. Firmly grasp throttle grip with left hand and fully depress throttle trigger to wide open position. Rapidly pull recoil starter handle/rope (D) until engine fires (or maximum five [5] pulls).
5. *Choke*  
After engine fires (or five [5] pulls), move choke lever back to "RUN" position. Hold throttle trigger fully depressed and pull recoil starter handle/rope until engine starts and runs. Release throttle trigger and allow unit to warm up at idle for several minutes.

#### NOTE

If engine does not start with choke in "RUN" position after 4 pulls, repeat instructions.

6. *Throttle Trigger*  
After engine warm up, gradually depress throttle trigger to increase engine RPM to operating speed.

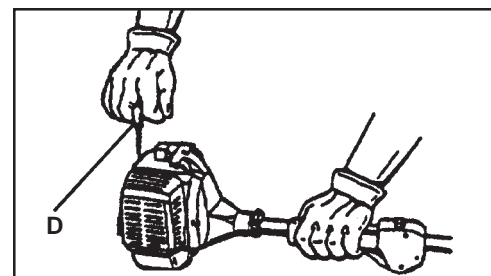
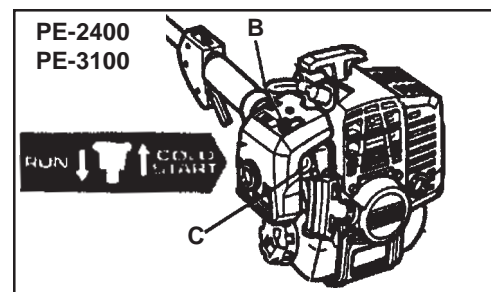
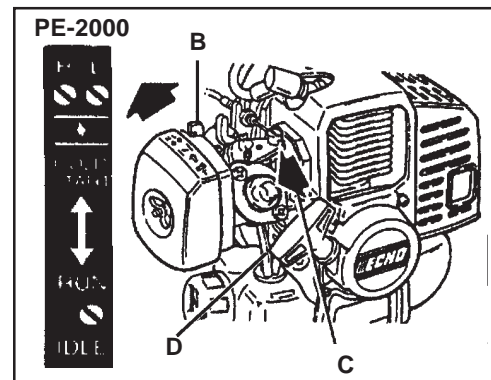
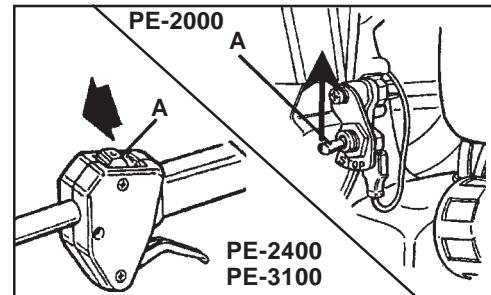

## STARTING WARM ENGINE

### WARNING DANGER

Blade should not move at idle. If blade moves, readjust carburetor according to Carburetor Adjustment instructions in the manual or see your ECHO dealer, otherwise serious personal injury may result.

1. *Stop Switch*  
Move stop switch button (A) away from the STOP position.
2. *Primer Bulb*  
Pump primer bulb (C) until fuel is visible in the "Clear" fuel return line. Pump bulb an additional 4 or 5 times.
3. *Recoil Starter*  
Starting - Lay trimmer on a flat, clear area and pull recoil starter handle/rope (D) until engine fires.

### NOTE

If the engine does not start after 4 pulls, use Cold Start Procedure.

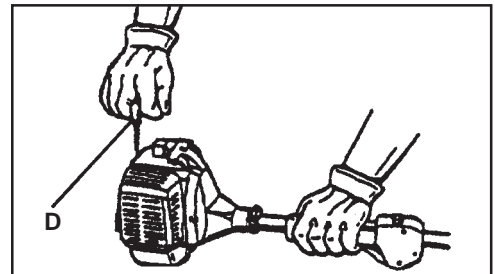
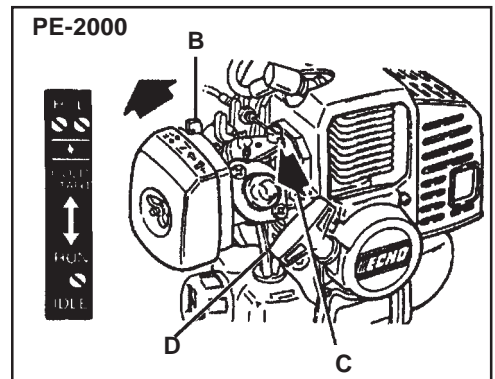
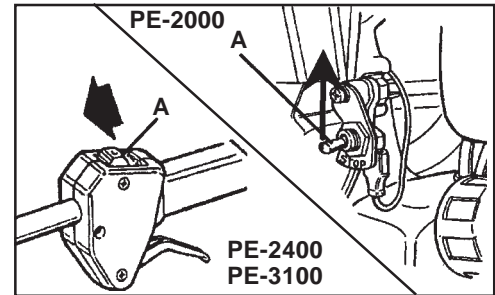

## STOPPING ENGINE

1. *Throttle Trigger*  
Release throttle trigger and allow engine to idle.
2. *Stop Switch*  
Place stop switch in STOP position.

### WARNING DANGER

If engine does not stop, close choke to stall engine. Have your ECHO Dealer inspect and repair stop switch before using edger again or serious personal injury may result.

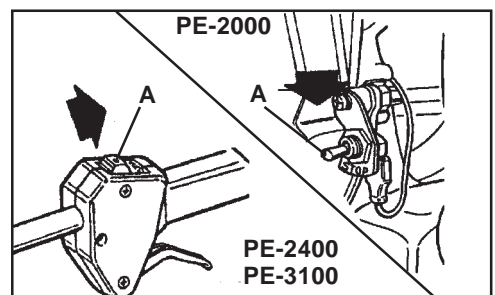

## OPERATING TECHNIQUES

1. Before edging, water the area to soften the ground to make edging easier.
2. Before edging, check the area and remove all obstacles and objects that could be thrown.
3. Plan to edge regularly to make it easier to keep a neat edge and to avoid having to make more than one pass.

### NOTE

Blade depth may have to be adjusted due to differences in height between the hard surface and the top of the grass.

### WARNING DANGER

Never adjust blade height with engine running, otherwise serious personal injury may result.

4. Adjust the blade's depth of cut to produce a fine cut between sidewalk and grass using a minimum blade depth, usually with about 1/2 in. of the blade into the ground.
5. Before edging, plan your direction of travel so that the unit will always be positioned on your right side and so that you walk on a hard surface whenever possible.
6. Hold edger as shown.

### WARNING DANGER

Before edging, be sure to read and understand the entire Operator's Manual to avoid the chance of serious injury.

7. When starting to edge, run the engine at full throttle, and lower the blade gently into the ground, being careful not to hit the concrete with the blade.
8. Don't force the blade. Move as quickly as the blade will allow.

### WARNING DANGER

The complete unit, specifically the drive shaft assembly may become very hot (too hot to touch) during use. Avoid contact during and immediately after operation, otherwise serious personal injury may result.

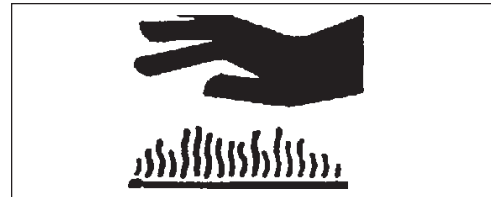
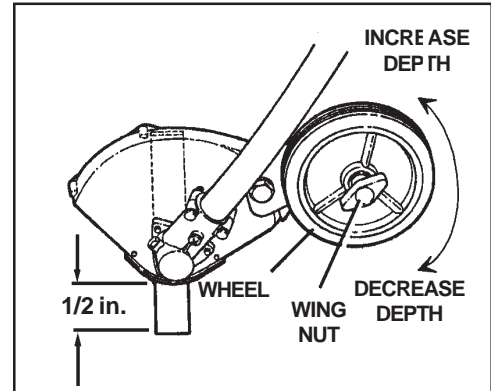



## MAINTENANCE

Your ECHO edger is designed to provide many hours of trouble free service. Regular scheduled maintenance will help your edger achieve that goal. If you are unsure or are not equipped with the necessary tools, you may want to take your unit to an ECHO Service Dealer for maintenance. To help you decide whether you want to DO-IT-YOURSELF or have the ECHO Dealer do it, each maintenance task has been graded. If the task is not listed, see your ECHO Dealer for repairs.

### SKILL LEVEL

- Level 1** = Easy to do. Most required tools come with unit.
- Level 2** = Moderate difficulty. Some specialized tools may be required.
- Level 3** = Experience required. Specialized tools are required. ECHO recommends that the unit be returned to your ECHO dealer for service.

ECHO offers **REPOWER™** Maintenance Kits and Parts to make your maintenance job easier. Just below each task heading are listed the various part numbers required for that task. See your ECHO dealer for these parts.

### MAINTENANCE INTERVALS

COMPONENT/ SYSTEM	MAINTENANCE PROCEDURE	REQ'D SKILL LEVEL	DAILY OR BEFORE USE	EVERY REFUEL	3 MONTHS OR 90 HOURS	6 MONTHS OR 270 HOURS	YEARLY 600 HOURS
<b>Recommended Echo Dealer Maintenance Procedures</b>							
Cylinder Exhaust Port	Inspect/Clean/Decarbon	<b>3</b>			I / C		
<b>Do-It-Yourself Maintenance Procedures</b>							
Air Filter	Inspect/Clean/Replace	<b>1</b>	I / C		R*		
Choke	Inspect/Clean	<b>2</b>	I / C				
Fuel Filter	Inspect/Replace	<b>1</b>			I		R *
Fuel System, leaks	Inspect/Replace	<b>1</b>	I	I / R *			
Cooling System	Inspect/Clean	<b>2</b>	I / C				
Muffler Spark Arrestor	Inspect/Replace	<b>2</b>	I / C		I / R*		
Drive Shaft	Grease	<b>2</b>			I (1)		
Gear Housing	Grease	<b>2</b>			I (2)		
Recoil Starter Rope	Inspect/Clean	<b>1</b>	I / C *				I / R*
Spark Plug	Inspect/Clean	<b>2</b>			I / C	R *	
Blade Replacement	Inspect/Replace	<b>1</b>	I	I	I / R*		
Screws/Nuts/Bolts	Inspect/Tighten/Replace	<b>1</b>	I / R *				

**MAINTENANCE PROCEDURE LETTER CODES: I = INSPECT, R = REPLACE, C = CLEAN**

**IMPORTANT NOTE** - Time intervals shown are maximum. Actual use and your experience will determine the frequency of required maintenance.

**MAINTENANCE PROCEDURE NOTES:**

(1) Apply ECHO® LUBE™ every 50 hours of use.

(2) Apply ECHO® LUBE™ every 15-25 hours of use.

\* All recommendations to replace are based on the finding of damage or wear during inspection..

## AIR FILTER

### Level 1.

**Tools required:** Cleaning brush, 25 or 50 mm (1 or 2 in.) medium bristle paint brush.

**Parts required:** (PE-2000) 90008 REPOWER AIR & FUEL FILTER KIT  
(PE-2400/3100) 90030 REPOWER AIR & FUEL FILTER KIT

1. Close choke (Cold Start Position). This prevents dirt from entering the carburetor throat when the air filter is removed. Brush accumulated dirt from the air cleaner area.
2. Remove the air cleaner cover. Clean and inspect the element for damage. If element is fuel soaked and very dirty, replace.
3. If element can be cleaned and reused, be certain it:
  - still fits the cavity in the air cleaner cover.
  - is installed with the original side out.

#### NOTE

Carburetor adjustment may be needed after air filter cleaning/replacement. See Carburetor Adjustment Section.

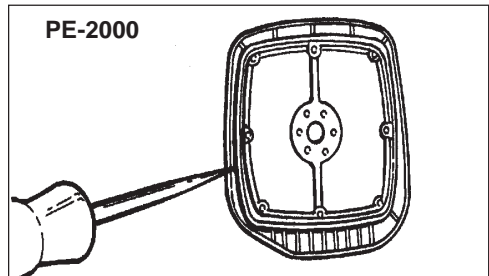
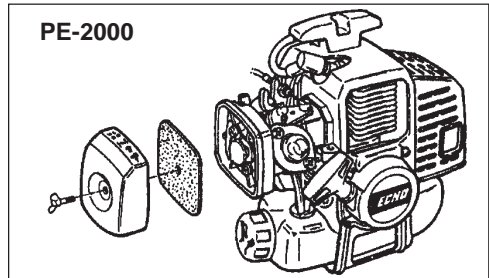

## FUEL FILTER

### Level 1.

**Tools required:** Fuel line hook, 200-250 mm (8-10 in.) length of wire with one end bent into a hook. Clean rag, funnel, and an approved fuel container.

**Parts required:** (PE-2000) 90008 REPOWER AIR & FUEL FILTER KIT  
(PE-2400/3100) 90030 REPOWER AIR & FUEL FILTER KIT

#### WARNING DANGER

Fuel is **VERY** flammable. Use extreme care when mixing, storing or handling.

1. Use a clean rag to remove loose dirt from around fuel cap and empty fuel tank.
2. Use the "fuel line hook" to pull the fuel line and filter from the tank.
3. Remove the filter from the line and install the new filter.

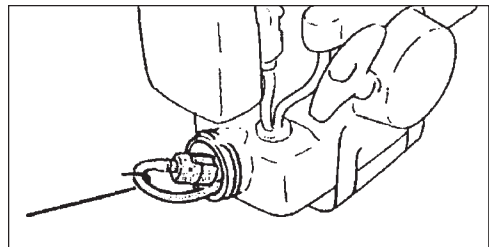

## SPARK PLUG

### Level 2.

**Tools required:** Srench (combination socket wrench and screwdriver) and Feeler gauge (preferably a wire gauge), Soft Metal Brush

**Parts Required:** Spark Plug, PE-2000 NGKBPM-7A  
PE-2400,3100 NGKBPM-7Y

1. Remove spark plug and check for fouling, worn and rounded center electrode.
2. Clean the plug or replace with a new one. DO NOT sand blast to clean. Remaining sand will damage engine.
3. Adjust spark plug gap by bending outer electrode.
4. Tighten spark plug to 145-155 kg/cm (125-135 in. lb.).

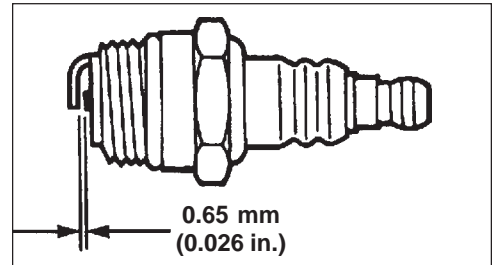
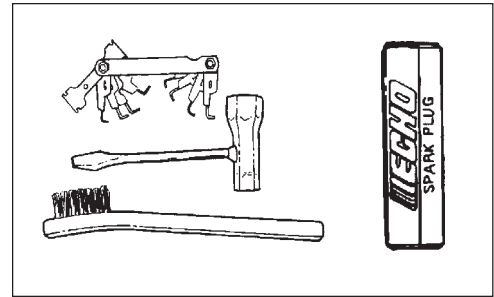

## COOLING SYSTEMS CLEANING

### Level 3.

**Tools required:** Cross Head Screwdriver, 3 and 4 mm Hex Wrench, Cleaning Brush, 25 or 50 mm (1 or 2 in.) medium bristle paint brush, Pointed Wood Stick.

**Parts Required:** None.

#### IMPORTANT

To maintain proper engine operating temperatures, cooling air must pass freely through the cylinder fin area. This flow of air carries combustion heat away from the engine.

Overheating and engine seizure can occur when:

- Air intakes are blocked, preventing cooling air from reaching the cylinder.
- Dust and grass build up on the outside of the cylinder. This build up insulates the engine and prevents the heat from leaving.

Removal of cooling passage blockages or cleaning of cooling fins is considered "Normal Maintenance." Any failure attributed to lack of maintenance is not warranted.

1. Remove spark plug lead and throttle linkage end from the carburetor swivel.
2. Remove the four screws that retain the cover. Two at the top of the recoil starter, two on either side of the front. Lift the engine cover (A) from the engine and lay to the front of the edger.

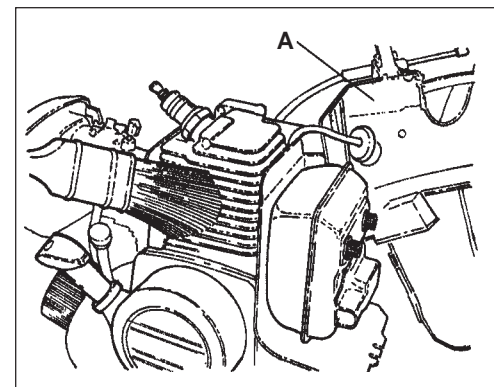
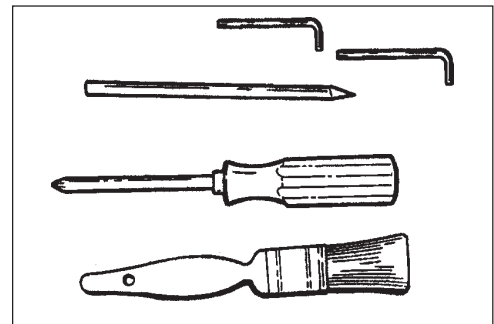

## NOTE

The throttle linkage remains assembled to the cover and the spark plug lead and grommet remain installed.

## IMPORTANT

DO NOT use a metal scraper to remove dirt from the cylinder fins.

3. Use the wooden stick or brush to remove dirt from the cylinder fins.
4. Remove grass and leaves from the grid between the recoil starter and fuel tank.
5. When installing the cover, be certain the tab of the metal deflector shield is in the slot of the cover.

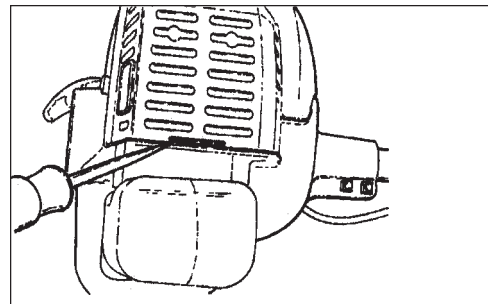
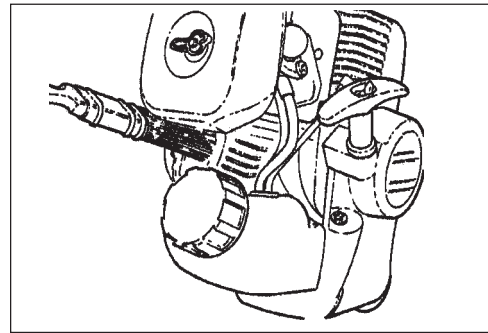

## EXHAUST SYSTEM

### Level 2.

**Tools Required:** Cross Head Screwdriver, 4mm Hex Wrench, Soft Metal Brush

**Parts Required:** (PE-2000/2400)(1) 14586652031 Spark Arrestor Screen.  
(PE-3100)(1) 14590555730 Spark Arrestor Screen.

1. Remove engine cover (A). See "Cooling Systems Cleaning" for step by step instructions.
2. Remove muffler cover (B), screen holder (C) PE-2000/2400 only, gasket (D) and screen (E) from muffler body.
3. Clean carbon deposits from screen and muffler components.
4. Replace screen if it is cracked, plugged or has holes burned through.
5. Reassemble parts with new gasket in reverse order.

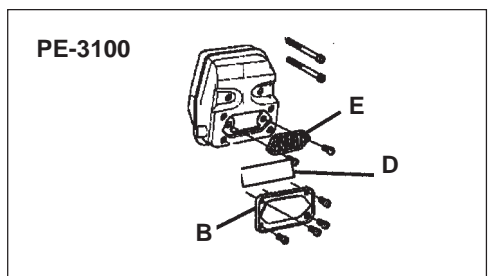
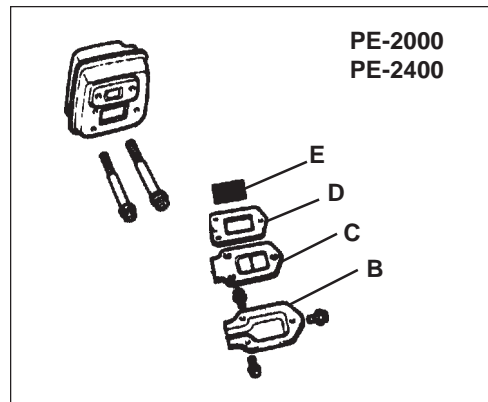
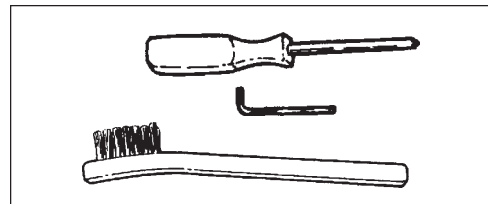

## CARBURETOR ADJUSTMENT

### Type 1E Emission Models

#### Level 2.

Parts required: None.

#### NOTE

Every unit is run at the factory and the carburetor is set in compliance with EPA Phase 1 and California Emission Regulations. In addition, the carburetor is equipped with HI (A) and LO (B) needle adjustment limiters that prevent settings outside acceptable limits.

1. Before adjusting the carburetor, clean or replace the air filter and spark arrester screen.
2. Start engine and run for several minutes to reach operating temperature.
3. Stop engine. Turn HI (A) speed needle CCW (counter clockwise) to stop. Turn LO (B) speed needle midway between full CCW and CW (clockwise) stops.
4. Idle Speed Adjustment.  
-Start engine and turn idle (C) speed adjustment screw CW until the blade begins to turn, then turn the screw CCW until blade stops turning. Turn screw CCW an additional 1/4 turn.
5. Accelerate to full throttle for 2-3 seconds to clear excess fuel from engine then return to idle. Accelerate to full throttle to check for smooth transition from idle to full throttle. If engine hesitates, turn LO (B) needle CCW an additional 1/8 turn and repeat acceleration. Continue adjusting until smooth acceleration results.
6. Check HI speed RPM at W.O.T. (Wide Open Throttle). HI speed RPM should be set to specifications found on page 10 "Specifications" of this manual.
7. Check idle speed and reset if necessary. If a tachometer is available, idle speed should be set to the specification found on page 10 "Specifications" of this manual.

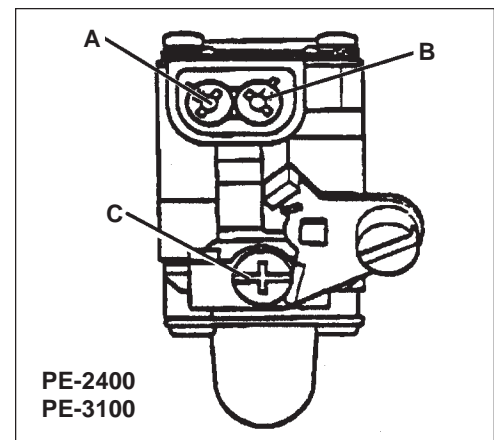
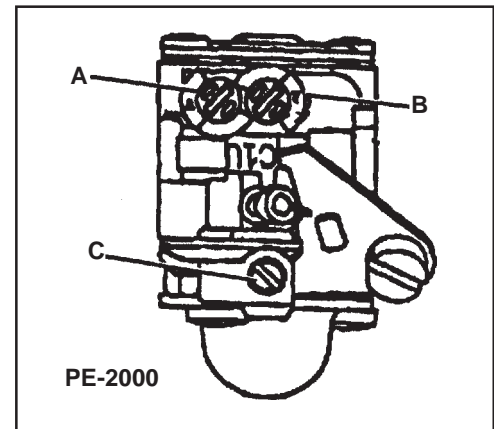
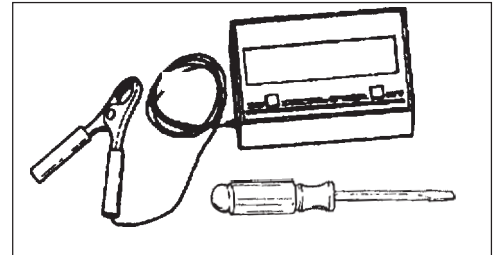

### WARNING DANGER

When carburetor adjustment is completed, blade should not move at idle, otherwise serious personal injury may result.

## CARBURETOR ADJUSTMENT

### Type 1 Non-Emission Models

#### NOTE

If carburetor has limiter caps follow "Carburetor Adjustment" procedures for Type 1E models on previous page.

### Idle Speed Adjustment

Turn "idle" speed adjustment screw (C) CW (clockwise) until cutting attachment begins to turn, then turn screw out CCW (counter clockwise) until cutting attachment stops turning. Turn screw out, CCW an additional 1/4 turn.

## WARNING DANGER

Blade must not turn when unit is idling, otherwise serious personal injury may result.

### Basic Setting

1. Stop engine and turn both LO (B) and HI (A) needles in, CW until they stop and are lightly seated.

#### IMPORTANT

**DO NOT** over tighten needles. Forcing them to tighten will damage the carburetor.

2. Turn needles out CCW  
 PE-2000 LO (B) 1-3/8 turns; HI (A) 1-7/8 turns  
 PE-2400 LO (B) 2-1/2 turns; HI (A) 2-1/4 turns  
 PE-3100 LO (B) 1-1/8 turns; HI (A) 1-1/8 turns

### Fine Tuning

#### (Requires Accurate Tachometer)

1. Start engine and allow to warm to operating temperature (minimum 2 - 3 minutes) varying engine speed from idle to full throttle.
2. Always begin fine tuning with LO (B) needle.
  - a. Lean drop-off - With engine idling, turn LO (B) needle slowly CW (in) to lean drop-off point. RPM will increase, then abruptly drop-off. Note this position. (1)
  - b. Rich drop-off - With engine idling, slowly turn LO (B) needle CCW (out) to rich drop-off point. RPM will increase then gradually slow and drop-off. Note this position. (2)
  - c. Final setting - Set needle at mid point between lean rich drop-off points. (3)
  - d. Turn needle 1/8 turn CCW (out) making mixture slightly richer. (4)
3. HI speed adjustment.  
 Adjust HI (A) needle with tachometer. Refer to Wide Open Throttle RPM settings listed in "Specifications" on page 10.
4. Check idle speed and reset if necessary. If tachometer is available, idle speed should be set to the specifications found on page 10 "Specifications" of this manual.

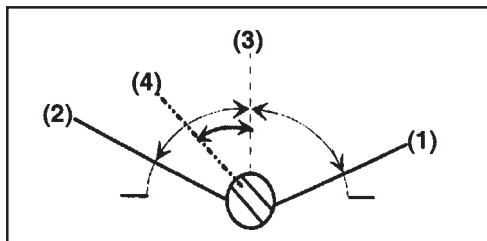
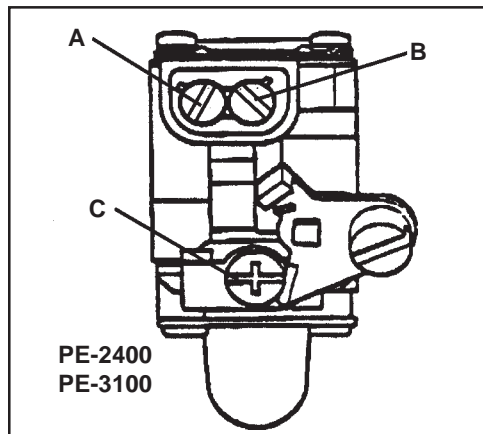
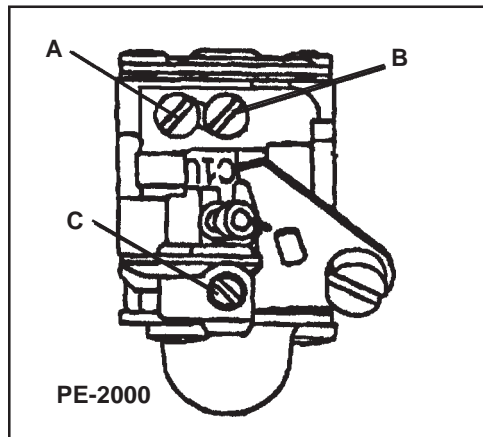
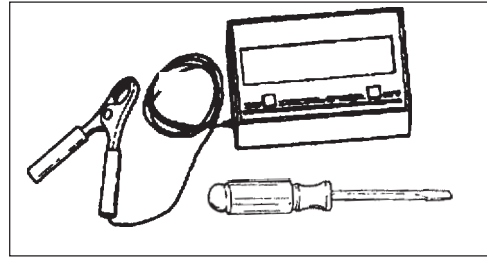

## WARNING DANGER

When carburetor adjustment is completed, the blade should not turn at idle, otherwise serious personal injury may result.

## LUBRICATION

### Level 1.

*Tools Required:* Srench, Locking Tool, Screwdriver, 8 mm Open End Wrench

*Parts Required:* EchoLube™ 8 oz. (P/N 91014) or Lithium Base Grease, Blade

#### NOTE

Grease gear case every 50 hours of use. Replace blade when it is worn shorter than 6". Remove blade and holders before greasing to prevent damage to gear and bearings.

1. Shut engine off.
2. Remove split pin (A).
3. Rotate blade until holes in inner blade adapter (B) and gear box align. Insert locking tool supplied to lock PTO shaft (C).

#### NOTE

Shield cover not shown for illustration clarity.

#### NOTE

Blade nut (D) is left hand thread.

4. Remove blade nut (D) in a clockwise direction using box wrench supplied. Remove outer blade adapter (E), blade (F) and inner blade adapter (B).
5. Remove plug (G) and grease gear housing. Do not over fill - grease will emerge between PTO shaft (C) and seal when overfull. Use good quality lithium multigrease.

#### NOTE

Shield cover not shown for illustration clarity.

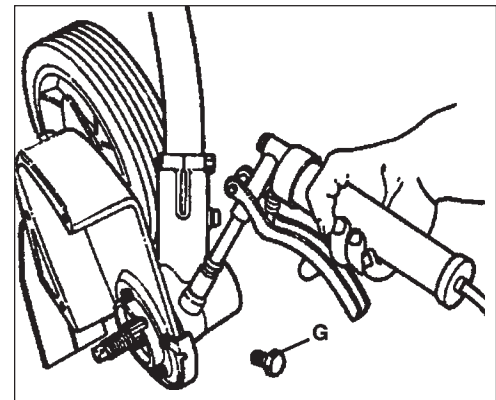
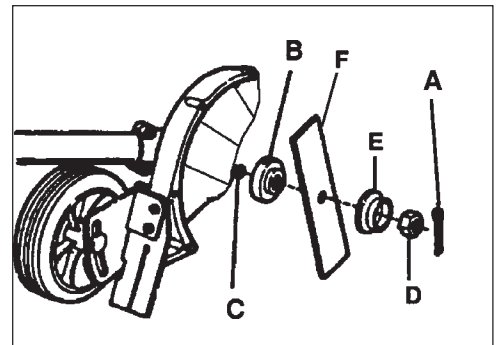
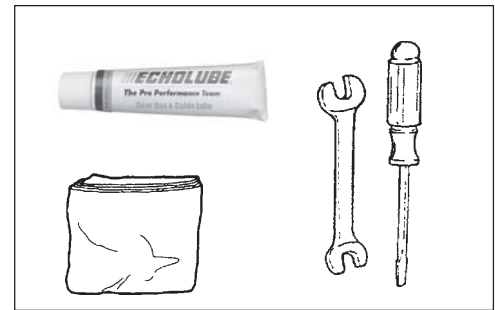

6. Install inner blade adapter (B) onto PTO shaft (C).
7. Install and center blade (F) onto inner adapter (B).

**WARNING**  **DANGER**

Use only ECHO approved attachments. Serious injury may result from the use of a non approved attachment combination. Read and comply with all safety instructions listed in this manual and safety manual. ECHO, INC. will not be responsible for the failure of cutting devices, attachments or accessories which have not been tested and approved by ECHO.

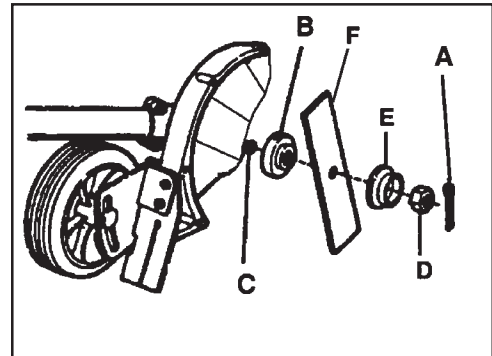

8. Install outer adapter (E) and nut (D). Tighten nut (D) firmly, counterclockwise (CCW).

**IMPORTANT**

Never reuse old split pin.

9. Install new split pin (A) (#89850201130) to secure nut.



## TROUBLESHOOTING

ENGINE PROBLEM TROUBLESHOOTING CHART				
Problem	Check	Status	Cause	Remedy
Engine cranks - starts hard/ doesn't start	Fuel at carburetor	No fuel at carburetor	Fuel strainer clogged Fuel line clogged Carburetor	Clean or replace Clean or replace See your Echo dealer
	Fuel at cylinder	No fuel at cylinder	Carburetor	See your Echo dealer
		Muffler wet with fuel	Fuel Mixture too rich	Open choke Clean/replace air filter Adjust carburetor See your Echo dealer
	Spark at end of plug wire	No spark	Stop switch off Electrical problem Interlock switch	Turn switch to ON See your Echo dealer See your Echo dealer
	Spark at plug	No spark	Spark gap incorrect Covered with carbon Fouled with fuel Plug defective	Adjust to .65mm (0.026 in.) Clean or replace Clean or replace Replace plug
Engine runs, but dies or does not accelerate properly	Air filter	Air filter dirty	Normal wear	Clean or replace
	Fuel filter	Fuel filter dirty	Contaminants/residues in fuel	Replace
	Fuel vent	Fuel vent plugged	Contaminants/residues in fuel	Clean or replace
	Spark Plug	Plug dirty/worn	Normal wear	Clean and adjust or replace
	Carburetor	Improper adjustment	Vibration	Adjust
	Cooling System	Cooling system dirty/plugged	Extended operation in dirty/dusty locations	Clean
	Spark Arrestor Screen	Spark arrestor screen plugged	Normal wear	Replace
Engine does not crank	N/A	N/A	Internal engine problem	See your Echo dealer

**WARNING**  **DANGER**

Fuel vapors are **extremely** flammable and may cause fire and/or explosion. **Never** test for ignition spark near an open spark plug opening, otherwise serious personal injury may result.

## STORAGE

### WARNING DANGER

During operation the muffler or catalytic muffler and surrounding cover become hot. Always keep exhaust area clear of flammable debris during transportation or when storing, otherwise serious property damage or personal injury may result.

### *Long Term Storage (over 30 days)*

Do not store your unit for a prolonged period of time (30 days or longer) without performing protective storage maintenance which includes the following:

1. Store unit in a dry, dust free place, out of the reach of children.

### WARNING DANGER

Do not store in enclosure where fuel fumes may accumulate or reach an open flame or spark.

2. Place the stop switch in the "STOP" position.
3. Remove accumulation of grease, oil, dirt and debris from exterior of unit.
4. Perform all periodic lubrication and services that are required.
5. Tighten all the screws and nuts.
6. **Drain** the fuel tank **completely** and pull the recoil starter handle several times to remove fuel from the carburetor.
7. Remove the spark plug and pour 7 cc (1/4 oz.) (1/2 tablespoon) of fresh, clean, two-stroke engine oil into the cylinder through the spark plug hole.
  - A. Place a clean cloth over the spark plug hole.
  - B. Pull the recoil starter handle 2-3 times to distribute the oil inside the engine.
  - C. Observe the piston location through the spark plug hole. Pull the recoil handle slowly until the piston reaches the top of its travel and leave it there.
8. Install the spark plug (do not connect ignition cable).

**NOTES**

# SERVICING INFORMATION

## PARTS

Genuine ECHO Parts and ECHO Re Power Parts and Assemblies for your ECHO products are available only from an Authorized ECHO Dealer. When you do need to buy parts **always** have the Model Number, Type number and Serial Number of the unit with you. You can find all three numbers on the engine housing. For future reference, write them in the space provided below.

Model No. \_\_\_\_\_ Type No. \_\_\_\_\_ SN. \_\_\_\_\_

## SERVICE

Service of this product during the warranty period must be performed by an Authorized ECHO Service Dealer. For the name and address of the Authorized ECHO Service Dealer nearest you, ask your retailer or call: 1-800-432-ECHO (3246). Dealer information is also available on our Web Site. When presenting your unit for Warranty service/repairs, proof of purchase is required.

## ECHO CONSUMER PRODUCT SUPPORT

If you require assistance or have questions concerning the application, operation or maintenance of this product you may call the ECHO Consumer Product Support Department at 1-800-673-1558 from 8:30 am to 4:30 pm (Central Standard Time) Monday through Friday. Before calling, please know the model and serial number of your unit to help your Consumer Product Support Representative.

## WARRANTY REGISTRATION

You may register your Echo equipment using the warranty registration card or register on-line at [www.echo-usa.com](http://www.echo-usa.com). Registering provides a direct link between you and ECHO if we find it necessary to contact you.

## ADDITIONAL OR REPLACEMENT MANUALS

**Safety Manuals** in English/Spanish or English/French are available free of charge, from your ECHO dealer or at [www.echo-usa.com](http://www.echo-usa.com).

**Operator's and Parts Manuals** are available by:

- Downloading free from [www.echo-usa.com](http://www.echo-usa.com)
- Purchasing from your Echo Dealer.
- Sending a check or money order for \$2.00 per Parts Catalog or \$1.50 per Operator's Manual made payable to ECHO, INCORPORATED. State on a sheet of paper the model number and serial number of the ECHO unit you have, part number of the manual (if known), your name and address and mail to address above.

**Safety Videos** are available from your Echo dealer. A \$5.00 shipping charge will be required for each video.

### Available Parts Catalogs

PE-2000 Type 1E	S/N 001001 & Up	Part Number 99922202766
PE-2000 Type 2E	S/N 001001 & Up	Part Number 99922202991
PE-2400 Type 1E	S/N 001001 & Up	Part Number 99922202767
PE-3100 Type 1E	S/N 001001 & Up	Part Number 99922202929

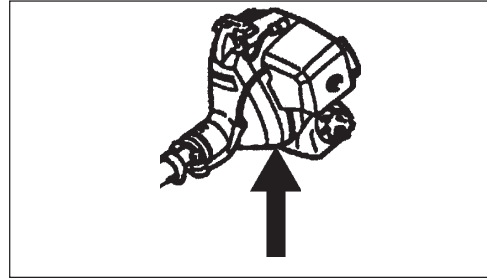

**DEALER?**  
Call  
**1-800-432-ECHO**  
or  
**[www.echo-usa.com](http://www.echo-usa.com)**

**CONSUMER PRODUCT  
SUPPORT**  
**1-800-673-1558**  
**8:30 - 4:30 Mon - Fri C.S.T.**

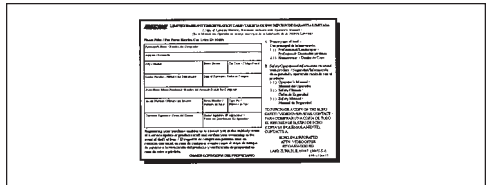

# **ECHO**

**ECHO, INCORPORATED**

400 OAKWOOD ROAD  
LAKE ZURICH, IL 60047

**[www.echo-usa.com](http://www.echo-usa.com)**

## Free Manuals Download Website

<http://myh66.com>

<http://usermanuals.us>

<http://www.somanuals.com>

<http://www.4manuals.cc>

<http://www.manual-lib.com>

<http://www.404manual.com>

<http://www.luxmanual.com>

<http://aubethermostatmanual.com>

Golf course search by state

<http://golfingnear.com>

Email search by domain

<http://emailbydomain.com>

Auto manuals search

<http://auto.somanuals.com>

TV manuals search

<http://tv.somanuals.com>