

ECLIPSE[®]

REAR CAMERA

MODEL **BEC105**

INSTALLATION MANUAL

Be sure to read this installation manual thoroughly prior to installation and making connections. If installation methods or non-standard parts not specified in this installation manual are used, accidents or injury may result.

Professional techniques and experience are required in order to install this system. It is recommended that you contact the place of purchase for installation to be carried out. After reading the installation manual thoroughly, keep them in a safe place for later reference.

To dealers:

Give this installation manual to the customer after installation and all connections have been completed.

Contents

Before installation

Components	2
For your safety in using the BEC105	2
Points to note after installing the rear camera	4
Installation Diagram	5

Installation

Installing the Rear Camera	6
Camera Angle Adjustment	11

Connections

System Connection Example	12
---------------------------	----

 **FUJITSU TEN**

Components

Check that all of the following components are present

Rear Camera Components

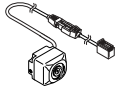

① Rear camera
x 1



② Bracket
x 1



③ Screw
(M3x6)x 2

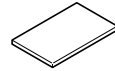

④ Double-sided tape
(Spare) x 1



⑤ Cable rail
x 6

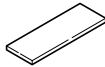

⑥ Harness affixing tape
x 2



⑦ Waterproof cushion
x 1

*The rear camera cable includes a 3-pin intermediate connector (male-female) to improve ease of installation.

For your safety in using the BEC105

Warnings and caution signs, illustrated below, are posted throughout this manual as well as on the BEC105.

They show safe and correct ways to handle the product to prevent personal injury to you and others and avoid damage to property.

Before reading through the manual, take time to read through and learn the important information listed in this section.



Warning

This "WARNING" sign indicates a situation in which incorrect handling may result in death or serious personal injury.



Caution

This "CAUTION" sign indicates a situation in which incorrect handling may result in personal injury or may result solely in damage to property.



Tip

This section contains information that can help to prevent problems and damage to the unit, and also contain other useful information.

Warning

- This unit is intended for operation in DC 12volt, negative-grounded vehicles only. Never use it in 24- volt vehicles such as heavy trucks or diesel vehicles with cold-region specifications.
- Do not install this product in locations where it may interfere with the operation of the steering wheel, shift lever, brake pedal, etc. Otherwise, an accident or injury may result.
- To prevent damage to the vehicle, confirm the locations of hoses, electrical wiring, and the fuel tank prior to drilling holes to install this product. Also, take care so that the product does not interfere and/or not come in contact with them. Otherwise, a fire may result.
- When using an existing nut and/or bolt from the vehicle to ground this product, do not use any that secure parts of the steering or braking systems. Otherwise, an accident may result.
- Be sure to disconnect the negative terminal of the vehicle's battery before prior to any installation work. If you do not do this, the positive and negative circuit may become shorted and electric shocks or injury may result.
- Bundle cables and harnesses with electrical tape or wire ties to prevent them from interfering with moving parts. If they should entangle with the steering wheel, shift lever or brake pedal, an accident may result.
- Do not disassemble or rebuild this product. Doing so may cause an accident, fire or electrical shock.
- If an abnormal situation occurs, such as foreign matter entering or liquid splashing on the product, or smoke or a strange odor emitting from the unit, shut off the product immediately and consult the dealer from whom you purchased it. Continued operation may cause an accident, fire or electrical shock.
- Do not install this product in locations where it may obstruct the driver's view, or where it may endanger passengers in the vehicle. Otherwise, an accident or injury may result.
- If using a drill to make holes, wear protective goggles to protect your eyes, otherwise debris may get into your eyes and cause injury or blindness.

Caution

- Do not allow the cable to touch metallic objects when routing it. If it touches metallic objects, they may become damaged and fire or electric shocks may result.
- Keep the cable away from hot objects when routing them. If the cable touches hot parts of the vehicle, the insulation may melt and cause short-circuits, which could result in fire or electric shocks.
- If changing the installation location of the camera, ask the place of purchase in order to ensure safe operation. Removing and installing the camera requires specialized skills.
- The camera cannot be used for any purpose other than as a vehicle-mounted camera. Incorrect use of the camera may result in electric shocks or injury.
- The purpose of this camera is to enable the driver to check behind the vehicle at times such as when reversing the vehicle or parking it. It should not be used for any other purpose.
- Always be sure to check that the surrounding area is safe when reversing the vehicle.
- Specialized training and experience is required in order to install and connect the camera. To ensure safety, ask the place of purchase to provide any installation and connection work. If the unit is connected incorrectly, serious damage to the vehicle may result.
- When installing this product, be sure to use the supplied mounting hardware. If parts other than those supplied are used, the unit may be damaged internally, or may not be held in place securely and become dislodged.
- Avoid installing the camera in places where it cannot be installed securely or may be subjected to excessive vibration. If this is not observed, the camera may fall off and cause traffic accidents and injury.
- Connect the camera according to the instructions given in this manual. If the camera is not connected correctly, fire or other accidents may result.
- Be careful not to allow the cable to touch threaded parts of the camera and moving parts such as seat rails when routing them, otherwise the cable may become damaged and short-circuits may occur which could result in fire, electric shocks or other accidents.

Points to note after installing the rear camera

- Method of use -

- Do not place too much reliance on the back-eye camera.
- The backeye camera is meant to be used as a supplementary aid to help in avoiding obstructions.
- If the lens is obscured by raindrops or similar, it may reduce in the effectiveness of the camera.
- The position of the images displayed on the screen will vary depending on the vehicle conditions (such as number of passengers and laden weight). Be sure to check for safety behind and around the vehicle while driving.
- Never reverse the vehicle while watching only the images produced by the camera. Be sure to use the interior mirror and door mirrors also to check for safety behind and around the vehicle.
- The characteristics of the camera lens will make all obstructions on the screen appear differently from their actual positions and distances.

- Handling -

- Do not subject the camera to strong shocks by hitting it firmly or knocking it against other objects. If this is not observed, it may damage the camera or cause problems with operation.
- Do not subject the camera lens to naked flames or sudden changes in temperature (example, "hair dryer") or hot water, otherwise it may damage the camera or cause problems with operation.
- Avoid using in direct sunlight for long periods of time. If this is not observed, burn-in of images may occur.
- The initial image that is displayed from the rear of the vehicle will be a white image (it may vary depending on the model of camera connected), but the image will gradually stabilize.
- If the camera is used for long periods of time, the increase in temperature may cause white marks or horizontal lines to appear. This is a characteristic of the CCD and is normal.
- Flickering may occur in the images if the camera is used underneath fluorescent light in 50 Hz power supply areas. This is normal and is not the sign of a malfunction.
- Do not clean the backeye camera unit and lens, the bracket, or the camera cable with volatile chemicals such as alcohol, kerosene, thinner or gasoline. Using such chemicals may cause warping, discoloration or other damage.
- Do not use cleaning substances that contain abrasive powders. Using such substances will damage the camera.
- If the lens area becomes dirty, wipe it gently with a soft cloth moistened with water. If the lens is rubbed firmly with a dry cloth, it may scratch the lens.
- Do not damage the camera cable. Water vapor or water may get inside the camera through the damaged section and cause problems with operation, fire, or electric shocks.
- If washing the vehicle with the backeye camera installed, do not apply water directly to the cabling to avoid water getting inside the vehicle compartment.
- Do not wash the backeye camera unit using automatic vehicle washing equipment or high-pressure washing equipment. If such equipment is used, the camera may fall off or water may remain inside the camera. This could result in problems with operation, fire, or electric shocks.
- Periodically inspect the camera and the bracket. Check that the mounting screws are not loose and that the adhesive areas are not peeling away. If the mounting screws are loose, they should be tightened. If this is not done, the camera may come off and fall down, or pedestrians may touch it resulting in problems with operation.
- If sunlight shines directly into the camera or other strong light (such as sunlight reflected from the bumper or headlights) shines into the camera, it may cause vertical lines (smearing) to appear at the top and bottom of the light source. This is normal and is not the sign of a problem.

Installation Diagram

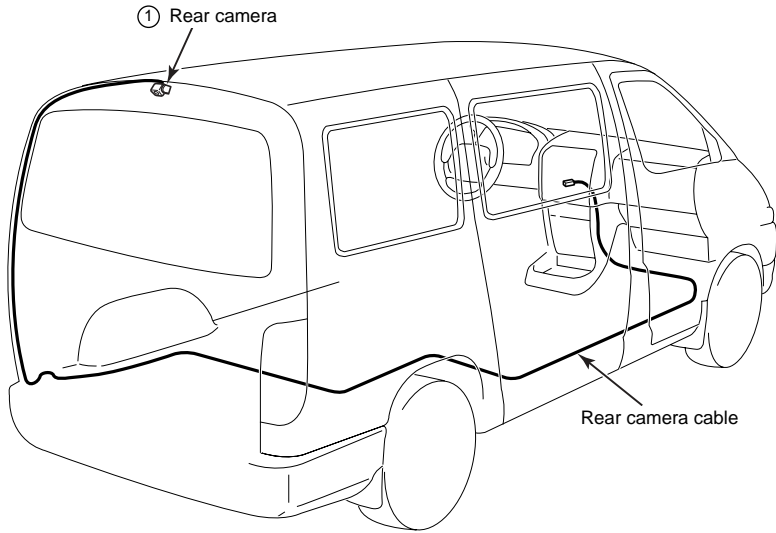

Installing the Rear camera

Notes on installation

Warning

- The cables should be secured with tape or a similar securing method to prevent any obstructions while driving. If they get wound around components such as the steering wheel, shifting lever or brake pedal, accidents may result.
- Install the rear camera bracket so that the entire mounting side surface can be affixed securely to the vehicle. If the contact surface area is insufficient, the camera may fall off while driving.
- Install the rear camera and the camera cable so that it does not interfere with the opening and closing of the back door.
- Do not install the camera where it will obstruct the driver's vision or where it will be an obstacle or obstruction while driving, otherwise traffic accidents may result.

Tip

- Before installing -

- If the weather is very humid, do not install the camera outdoors.
(Humidity will cause the adhesive to become weaker and the camera may fall off while driving.)
- Be sure to read the installation manual for the main unit that the camera is being connect to.

- When performing the installation -

- For 24 hours after installing the camera, the vehicle can be driven without problems, but avoid spraying the camera with water or exposing it to rain. Let it sit naturally without applying any excessive force to it.
- The adhesive force of the double-sided tape will be reduced at low temperatures (20°C) or less. Use a hair dryer or a similar technique to warm the double-sided tape before attaching it.
- Do not use a dryer or a similar device on at the rear camera or lens.

Tip

- Check the installation position prior to installing to ensure that the rear camera and the camera cable does not interfere with the opening and closing of the back door.
- Do not peel the double-sided tape away from its backing paper.

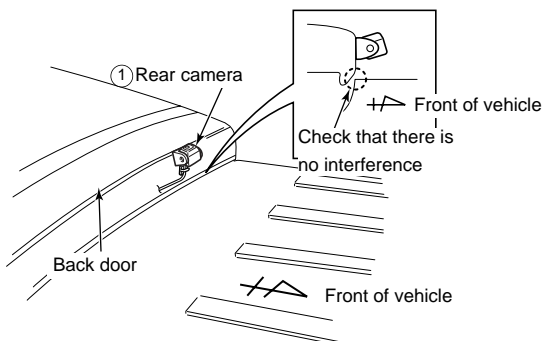

- 1** Decide on the installation position for the rear camera.



Tip

Note the following when deciding on the installation position for the rear camera.

position for the rear camera.

- Provisionally attach the rear camera with tape and adjust its angle (see page 11) in a position to view the rear of the vehicle. When the double-sided tape has been used once, the adhesive will be reduced if it is used again.
- Install the rear camera in a position where light from sources such as a high mounted brake light will not shine into the camera lens.

- If installing underneath a rear spoiler (example) -

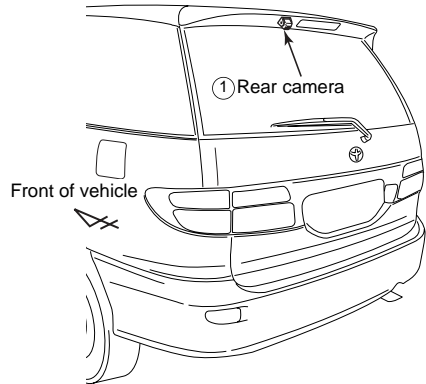

- If installing directly to the back door (example) -

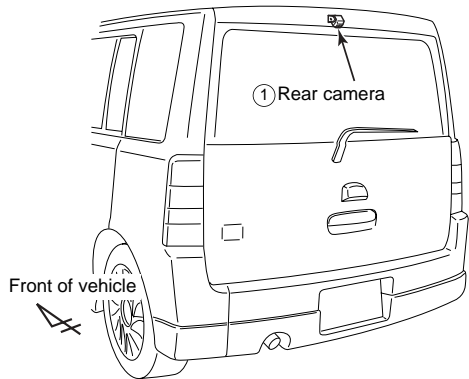

- If installing underneath a rear spoiler (example) -

2 Wipe the installation surface free of any dirt, water or grease.

3 Peel off the backing paper from the double-sided tape on the bracket, and affix the bracket to a flat part of the rear spoiler.

Tip

- After affixing the bracket, push the bracket firmly on the mounted surface ensure that it is securely attached.
- The adhesive strength of the double-sided tape will be reduced at low temperatures (20°C) or less. Use a hair dryer or a similar technique to warm the double-sided tape before attaching it.

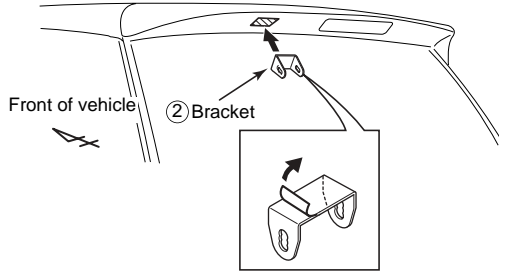

- If installing underneath a rear spoiler (example) -

4 Install the rear camera to the bracket.

Tip

- Install so that the "ECLIPSE" logo is facing upward.

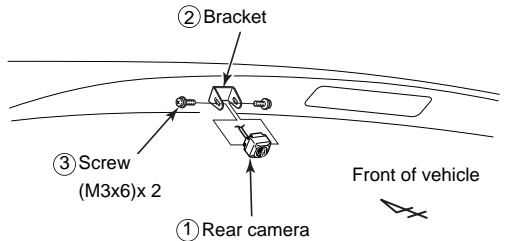

- If installing underneath a rear spoiler (example) -

5 Pull the rear camera cable inside the back door while securing it with the cable rails and commercially-available clamp.

Tip

- The cable rails should be cut to appropriate lengths.

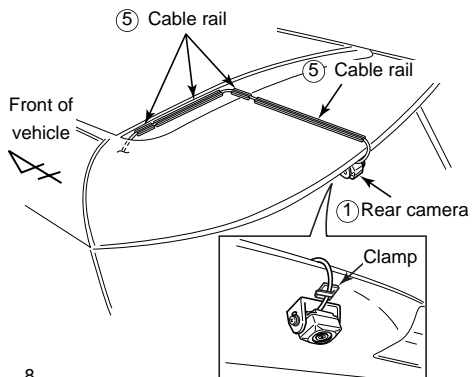

– If installing underneath a rear spoiler (example) –

- 6 Wipe the installation surface free of any dirt, water or grease.
- 7 Peel off the backing paper from the double-sided tape on the bracket, and affix the bracket to a flat part of the back door.

 **Tip**

- After affixing the bracket, push the bracket firmly on the mounted surface ensure that it is securely attached.
- The adhesive strength of the double-sided tape will be reduced at low temperatures (20°C) or less. Use a hair dryer or a similar technique to warm the double-sided tape before attaching it.

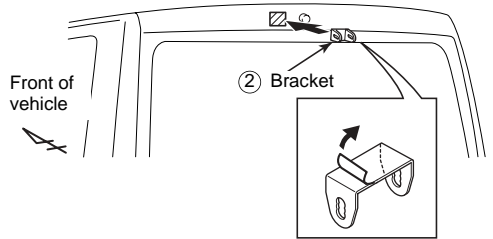

– If installing directly to the back door (example) –

- 8 Install the rear camera to the bracket.

 **Tip**

- Install so that the "ECLIPSE" logo is facing upward.

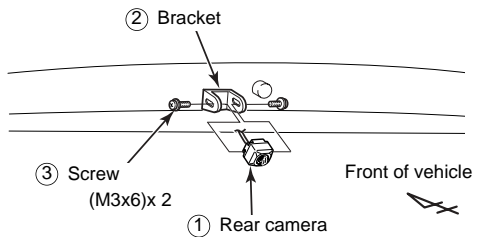

– If installing directly to the back door (example) –

- 9 Pull the rear camera cable inside the back door while securing it with the cable rails.

 **Tip**

- The cable rails should be cut to appropriate lengths.

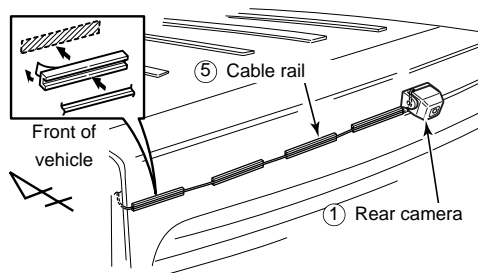

- 10** Route the rear camera cable while securing it with the cable rails, commercially-available cable tie, and commercially-available clamp.

Tip

- The cable rails should be cut to appropriate lengths.

Warning

- Confirm that the rear camera cable does not get pulled and that the cable ties and clamps do not come off when the back door is opened and closed.
- Take care when routing the cable through the trunk to ensure that rainwater cannot get inside the vehicle.

- 11** Place the cable into the slit of the waterproof cushion.
- 12** Attach the waterproof cushion to the weatherstrip.

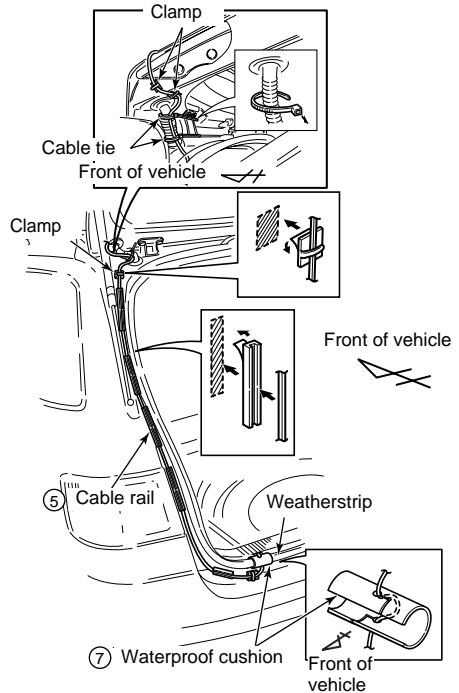

- 13** Route the rear camera cable while securing it with the harness affixing tape.
- 14** Cut the luggage finish plate so that the camera cable does not get caught on it.

Tip

- Check that there is no rib on the underside of the luggage finish plate at the notch position.

Warning

- Take care when routing the cable through the trunk to ensure that rainwater cannot get inside the vehicle.

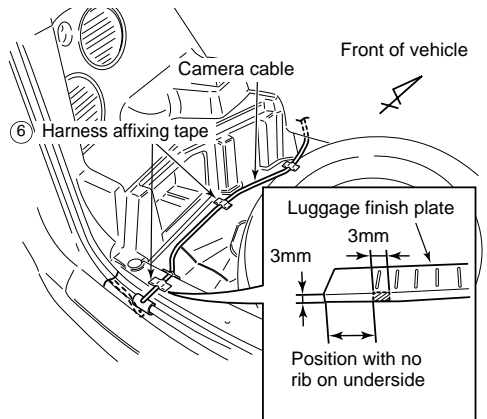

- 15** Route the rear camera cable through to the main unit.
- 16** Wrap the intermediate connector of the rear camera cable with harness affixing tape to dampen any noise.

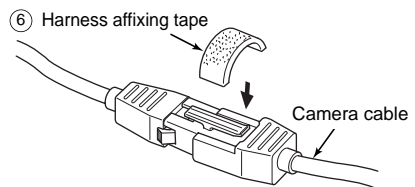

Camera Angle Adjustment

⚠ Warning

- When adjusting the camera images, apply the vehicle's parking brake and be sure to chock the wheels of the vehicle so that the vehicle will not move, otherwise accidents or injuries may occur.

- 1 After connecting the rear camera cable to the main unit, connect the battery cable.
- 2 Move the selector lever to the R position to display images from behind the vehicle.
- 3 Loosen the adjustment screw and adjust the angle of the camera so that the rear of the vehicle (rear window, back door, rear bumper, etc.) are visible as shown in the diagram.

- Main unit -

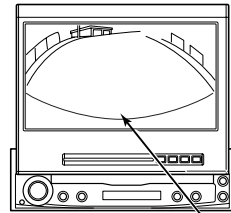

Rear of vehicle

- 4 After adjusting the angle, securely tighten the adjustment screw.
At this time, secure the bracket adjustment screw so that it is at either end of the slot in the bracket.

👉 Tip

- Prior to adjusting the rear camera angle, check that gear was shifted into Park or Neutral position.
- Be careful not to pull on the cable when adjusting the angle of the rear camera.
- Check the adjustment screw regularly and re-tighten if it becomes loose.

- Angle adjustment -

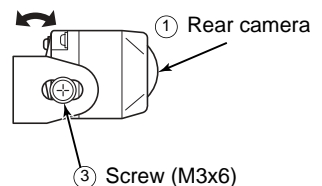

- Mounting adjustment -



System connection example

⚠ Warning

- Never cut the insulation on the power cable or use it to power any other equipment. If the rated current capacity of the power cable is exceeded, fire and electric shocks may result.
- The cables should be bound together with tape or with a similar technique so that they do not interfere with driving. If they become wound around parts such as the steering wheel, shifting lever or brake pedal, accidents may result.

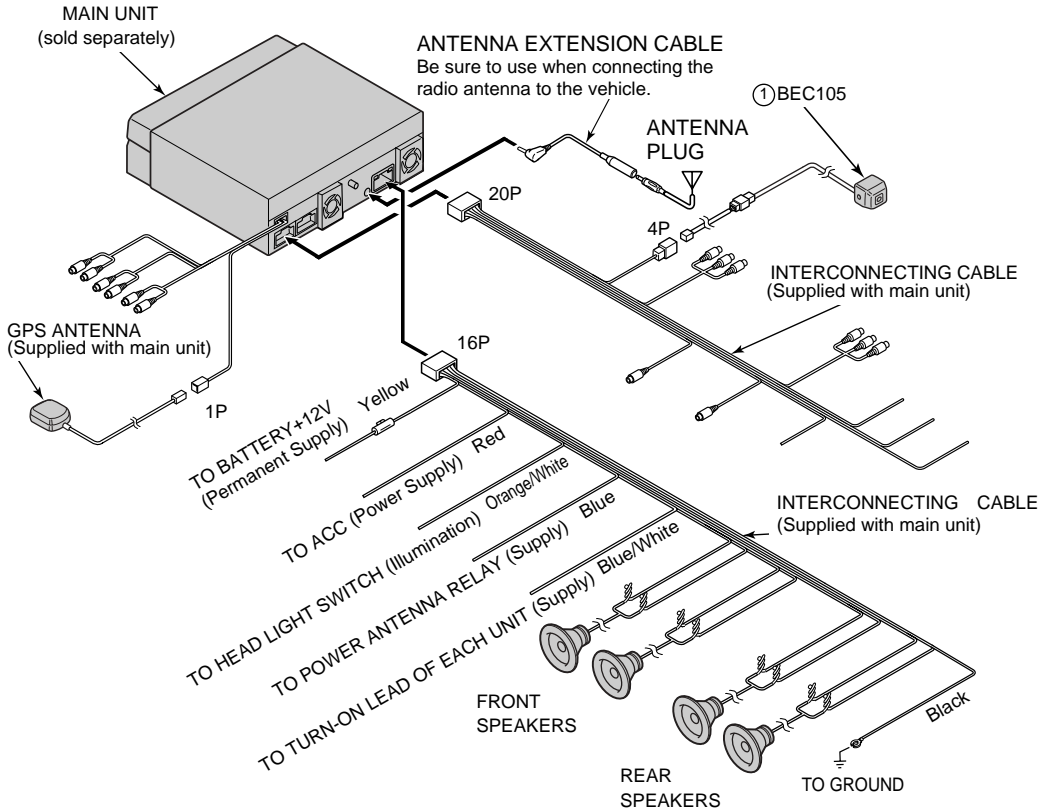

👉 Tip

- Install all components and route the cables before connecting up the main unit.
- The terminals at the rear of the main unit will vary depending on the type of main unit used. Always be sure to refer to the installation manual for the main unit.
- If any cables are unconnected, wrap their ends with PVC tape or a similar technique to insulate them.

090003-28750700
0507DE (CN)

Free Manuals Download Website

<http://myh66.com>

<http://usermanuals.us>

<http://www.somanuals.com>

<http://www.4manuals.cc>

<http://www.manual-lib.com>

<http://www.404manual.com>

<http://www.luxmanual.com>

<http://aubethermostatmanual.com>

Golf course search by state

<http://golfingnear.com>

Email search by domain

<http://emailbydomain.com>

Auto manuals search

<http://auto.somanuals.com>

TV manuals search

<http://tv.somanuals.com>