

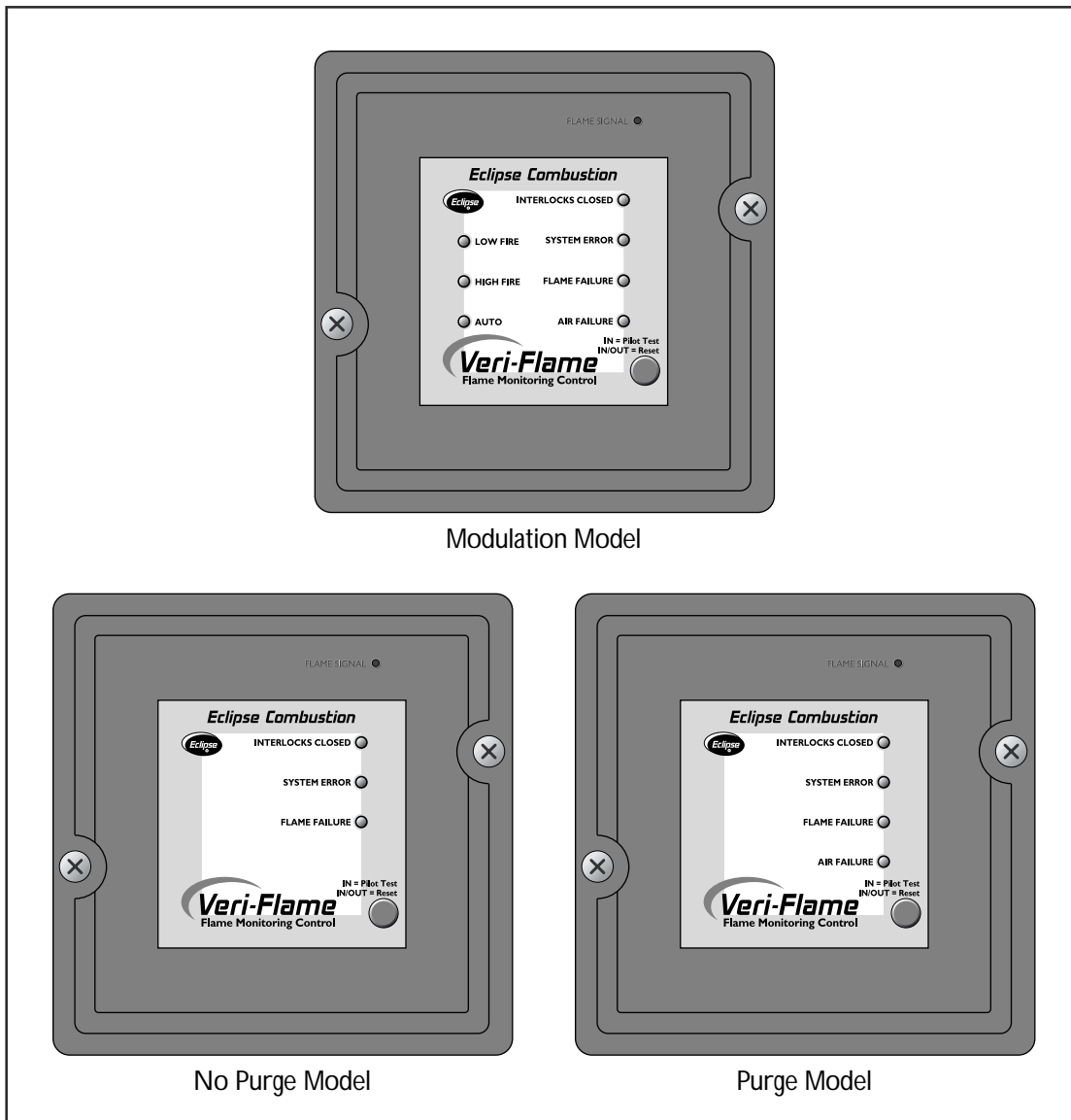

VeriFlame Single Burner Monitoring System

Model 5600

Version 1.21



COPYRIGHT

Copyright 1997 by Eclipse Combustion, Inc. All rights reserved worldwide. This publication is protected by federal regulation and shall not be copied, distributed, transmitted, transcribed or translated into any human or computer language, in any form or by any means, to any third parties, without the express written consent of Eclipse Combustion, Inc., Rockford, Illinois, U.S.A.

DISCLAIMER NOTICE

In accordance with the manufacturer's policy of continual product improvement, the product presented in this brochure is subject to change without notice or obligation.

The material in this manual is believed adequate for the intended use of the product. If the product is used for purposes other than those specified herein, confirmation of validity and suitability must be obtained. Eclipse Combustion, Inc. warrants that the product itself does not infringe upon any United States patents. No further warranty is expressed or implied.

We have made every effort to make this manual as accurate and complete as possible. Should you find errors or omissions, please bring them to our attention so that we may correct them. In this way we hope to improve our product documentation for the benefit of our customers. Please send your corrections and comments to our Marketing Communications Manager.

LIABILITY AND WARRANTY

It must be understood that Eclipse Combustion's liability for its products, whether due to breach of warranty, negligence, strict liability, or otherwise, is limited to the furnishing of burner monitoring system replacement parts and Eclipse Combustion will not be liable for any other injury, loss, damage or expenses, whether direct or consequential, including but not limited to loss of use, income of, or damage to material arising in connection with the sale, installation, use of, inability to use or the repair or replacement of Eclipse Combustion's products.

Eclipse Combustion, Inc., for a period of one year from shipment, warrants each Veri-Flame burner monitoring system to the original purchaser to be free from defects in material and workmanship under normal use as defined hereafter. Any operation expressly prohibited in this Guide, any adjustment or assembly procedures not recommended or authorized in these instructions, shall void the warranty.

About this manual

AUDIENCE

This manual has been written for the people who select and install the product and the technicians who work on it. They are expected to have previous experience with this kind of equipment.

SCOPE

This manual contains essential information for the proper installation and operation of the Eclipse Veri-Flame Burner Monitoring System.

Following the instructions in this manual should assure trouble-free installation and operation of the monitoring system. Read this manual carefully. Make sure that you understand its structure and contents. Obey all the safety instructions.

Do not deviate from any instructions or application limits in this manual without written consent from Eclipse Combustion, Inc.

If you do not understand any part of the information in this manual, do not continue. Contact your Eclipse sales office or Eclipse Combustion, Inc., Rockford, Illinois.

DOCUMENT CONVENTIONS

There are several special symbols in this document. You must know their meaning and importance.

The explanation of these symbols follows. Please read it thoroughly.



Danger:

Indicates hazards or unsafe practices which WILL result in severe personal injury or even death.

Only qualified and well trained personnel are allowed to carry out these instructions or procedures.

Act with great care and follow the instructions.



Warning:

Indicates hazards or unsafe practices which could result in severe personal injury or damage.

Act with great care and follow the instructions.



Caution:

Indicates hazards or unsafe practices which could result in damage to the machine or minor personal injury.

Act carefully.



Note:

Indicates an important part of the text.

Read the text thoroughly.

HOW TO GET HELP

If you need help, you can contact your local Eclipse Combustion sales office.
You can also contact Eclipse Combustion, Inc. at:

1665 Elmwood Road
Rockford, Illinois 61103 USA

Phone: 815-877-3031

Fax: 815-877-3336

E-mail: eclipse@eclipsenet.com

<http://www.eclipsenet.com>



Table of Contents

	About this manual	3
	Table of contents	5
1	Introduction	8
	Product Description	8
2	Specifications	9
	Introduction	9
	Specifications	9
	Dimensions	9
3	DIP Switch Selection	12
	Introduction	12
	DIP Switch Location	12
	DIP Switch Access	12
	No Purge DIP Switch Settings	12
	Modulation & Purge DIP Switch Settings	13
4	Function Summary	14
	Introduction	14
	Standard Features	14
	Combustion Air Flow Check	14
	Main Fuel Valve Closed switch	14
	Low Fire Start	14
	High Fire/High Fire Purge Check	14
	Recycle Mode	14
	Pilot Test Mode	14
	Interrupted or Intermittent Pilot	15
	Post Purge	15
	Spark, Pilot Flame & Main Flame Separation	15
	System Error & Lockout Conditions	15
	High to Low Fire Purge Modulation Capability with High to Low Fire Position Switch Interlocks	16

4	Optional Features	16
	Pilot Test Mode Sequence	16
	Air Switch Input Hold	16
	Remote Display & Power Supply	16
	Status Lights & Push-buttons	17
	Interlocks Closed	17
	Air Failure	17
	System Error	17
	Burner On	17
	Flame Failure	17
	Low Fire	17
	High Fire	17
	Auto	17
	Test/Reset	17
5	System Installation	18
	Introduction	18
	Interlocks and Limit Switch Input	18
	Combustion Air Switch Input	18
	Ignition Wiring	18
	Low Fire Input	19
	Main Valve Closed switch	19
	High Fire Input	19
	Remote Reset	19
	Remote Display & Power Supply	19
	Purge and No Purge Wiring Diagram (Figure 5.1)	20
	Modulation Wiring Diagram (Figure 5.2)	20
	Typical Connections for all Models (Figure 5.3)	21
6	Sensor Installation	24
	Introduction	24
	Sensor Wiring	24
	Flame Rods	25
	Scanners	25
	Scanner Sighting Considerations	25
7	Test Procedures	26
	Introduction	26
	Flame Signal Strength	26
	Minimum Pilot Test	26
	Pilot Flame Failure Test	27
	Main Flame Failure Test	27
	Spark Sighting Test	27
	Limits & Interlock Tests	27

8	Maintenance & Troubleshooting	28
	Introduction	28
	Maintenance	28
	Monthly Checklist	28
	Yearly Checklist	28
	Troubleshooting	29
	LED Status	30
	LED Status & Conditions for No Purge Models (Table 8.1)	30
	LED Status & Conditions for Purge Models (Table 8.2)	31
	LED Status & Conditions for Modulation Models (Table 8.3)	32
9	Remote Display Messages	33
	Introduction	33
	Veri-Flame Operating Sequence (Table 9.1)	34
	Remote Display Diagnostic Messages (Table 9.2)	38
	Appendix	41
	Conversion Factors	41
	Illustrated Parts List	42

Introduction

1

PRODUCT DESCRIPTION

The Eclipse Combustion Veri-Flame Single Burner Monitoring System controls the start-up sequence and monitors the flame of single gas, oil, or combination gas/oil burners. There are three different models to the Veri-Flame line: the no purge, the purge and the modulation models. Each model features field selectable trial for ignition (TFI). Each model is also available for use with four types of flame sensor: ultraviolet (UV), self-check UV, infrared (IR) and flame rod.

The **Veri-Flame No Purge** and **Purge** models are available in three different series—5602, 5603 and 5605. The 5602 Series is UL listed, CSA certified, FM approved and IRI acceptable; the 5605 Series is UL listed, FM approved and IRI acceptable. The 5603 Series is for 240VAC applications not requiring US or Canadian certifications.

The **Veri-Flame Modulation** model is available in two different series: 5602 and 5603. Both series are capable of modulation (high and low fire purging). The 5602 Series is UL listed, CSA certified, FM approved and IRI acceptable. The 5603 Series is for 240VAC applications not requiring US or Canadian certifications.

Figure 1.1 Veri-Flame Single Burner Monitoring System (Purge Unit Shown)





Specifications

INTRODUCTION

This section gives a detailed overview of Veri-Flame specifications and dimensions.

Specifications





PARAMETER	DESCRIPTION			
Supply	<ul style="list-style-type: none"> Series 5602 & 5605: 120 VAC (+10%, -15%), 50/60 Hz standard. Series 5603: 240 VAC (+10%, -15%), 50/60 Hz standard. Internal power consumption: 12 VA (excluding external connected loads). 			
Temperature Ranges	Unit	Model Nos.	Temperature Range	
	Veri-Flame	All Models	-40° to +60°C (-40° to +140°F)	
	90° U.V. Scanner	5600-90A	-20° to +60°C (0° to 140°F)	
	U.V. Scanner	5600-91	-20° to +125°C (0° to +257°F)	
	NEMA4 UV Scanner	5600-91N4	-20° to +125°C (0° to +257°F)	
	I.R. Scanner	5600-92B	-40° to +110°C (-40° to +230°F)	
	UV/IR Scanner	5600-92SC	-20° to +80°C (0° to +176°F)	
	Self-Check U.V.	5602-91	-20° to +60°C (0° to +140°F)	
	Remote Display	5602DB	0° to 50°C (32° to 122°F)	
Remote Display	5602DBP	0° to 50°C (32° to 122°F)		
Flame Failure Response	3 seconds ±0.5 seconds.			
Trial For Ignition (TFI)	<i>No Purge & Purge Models:</i> Series 5602 & 5603: five or 10 seconds selectable. Series 5605: ten or 15 seconds selectable. Modulating Model: 5 or 10 seconds selectable			
Pilot Interrupt (if selected)	10 seconds.			
Purge Time	Selectable from 0-225 seconds in 15 second increments.			
Output Ratings for 120 VAC (maximum total connected load not to exceed 15 amps)	Function	Terminals	UL, CSA Inductive Load	Relay Contact Rating Resistive Load
	Gas Valve	3, 5	175VA, 1/10 HP	10 amps
	Ignition	4	375 VA	10 amps
	Motor or Contactor	8	470 VA, 1/2 HP	16 amps
Control Signal	A, 10, 11, 12, 13	175VA	10 amps	
Output Ratings for 240 VAC (maximum total connected load not to exceed 15 amps)	Function	Terminals	Relay Contact Rating Resistive Load	
	Valves, Ignition	3, 4, 5,	5 amps	
	Motors or Contactor	8	16 amps	
	Alarm	A	5 amps	
Control	10, 11, 12, 13	5 amps		

(continued onto next page)

Specifications (continued)

PARAMETER	DESCRIPTION
Approvals (See chart below.)	<ul style="list-style-type: none"> • No Purge & Purge Models: Series 5602: UL listed, CSA certified, FM approved and IRI acceptable. Series 5603: No approvals. Series 5605: UL listed, FM approved and IRI acceptable. • Modulating Models: Series 5602: UL recognized (must be mounted in panel), CSA certified, FM approved and IRI acceptable. Series 5603: No approvals.
Shipping Weight	<ul style="list-style-type: none"> • 1.4 kilograms (3 lbs.) for all Veri-Flame models. • 0.9 kilograms (2 lbs.) for Models 5602-10 & 5602-10-1 bases. • 1.2 kilograms (2.6 lbs.) for Model 5602-40 base.

Approval Information

	UL Listed, Guide No. MCCZ, File MH12613
	UL Recognized, Guide No. MCCZ2, File MH12613
	CSA Certified, Class No. 2632 01, File 37456
	FM Approved, Class No. 7610, Report 1Y2A4.AF

Dimensions

Veri-Flame Unit/All Models

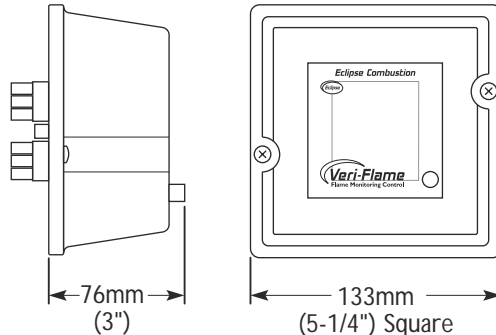

Veri-Flame Bases/Purge & No Purge Models

Model Number 5602-10

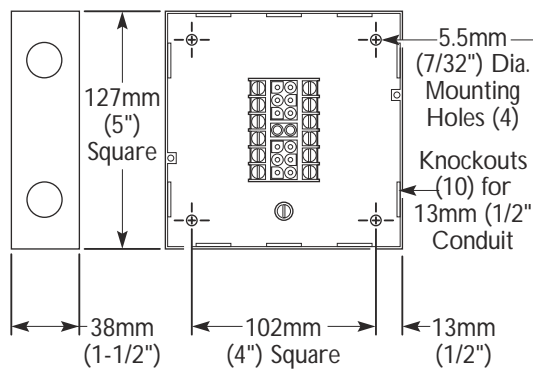

Model Number 5602-10-1

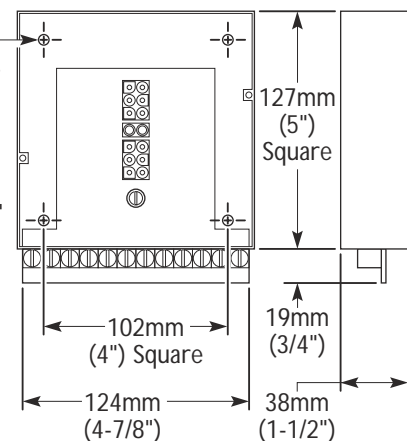

Dimensions (continued)

Veri-Flame/Modulating Model with Base Model Number 5602-40

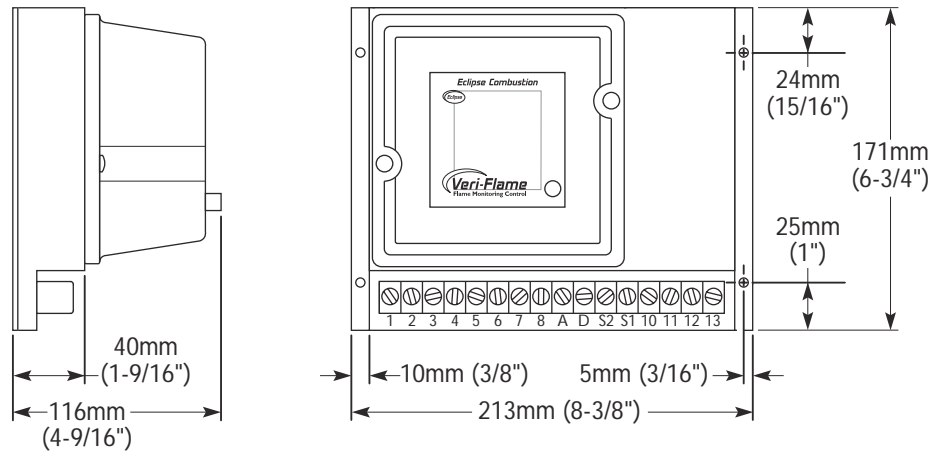

Remote Display Model Number 5602-DB

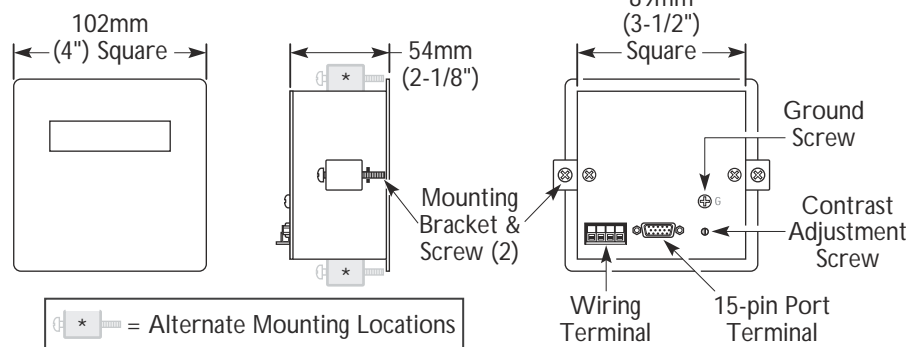

24VDC Power Supply for Remote Display 5602-DB

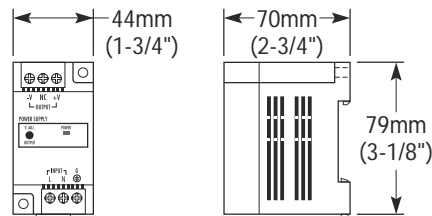

Remote Display Model Number 5602-DBP

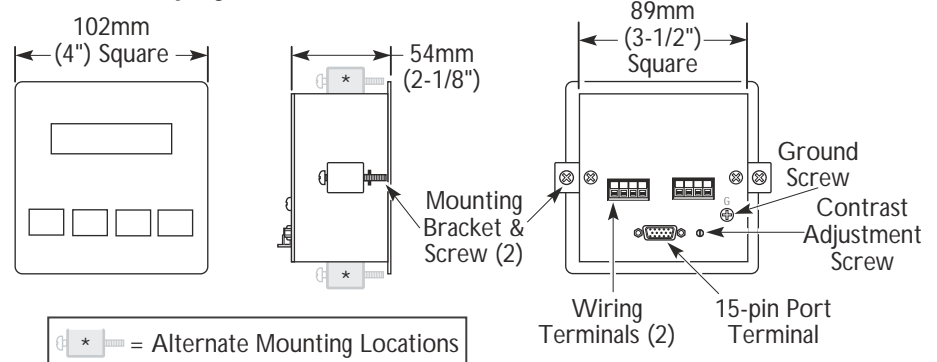

DIP Switch Selection

3

INTRODUCTION

This section details the location, selection and description of the Veri-Flame DIP switches, which allow for sequence and timing functions as well as system configuration.



Caution

To avoid electric shock, shut off the power supply when installing or removing any control device. Flame monitoring systems must be installed by a qualified, licensed technician.

DIP Switch Location

All of the DIP switches are located in the back of each Veri-Flame unit (see Figure 3.1 on page 13, or the photograph on page 8).

DIP Switch Access

To gain access to the DIP switches, the Veri-Flame must be separated from the back box (for visual reference, please refer to "Dimensions" on page 10). This separation will expose the DIP switches on the back of the Veri-Flame unit.

No Purge DIP Switch Settings

No Purge models of the Veri-Flame only use three of the eight DIP switches, as shown in the labels in Figure 3.2 on page 13. They are as follows:

SW1: Recycling mode selection (On = Recycling; Off = Non-recycling)

SW2: Pilot selection (On = Intermittent, where pilot remains on during burner cycle; Off = Interrupted, where pilot valve closes after main burner is established).

SW3: Trial-for-ignition (TFI) range selection (For 5602/5603 units: On = 10 seconds; Off = 5 seconds. **For 5605 units:** On = 10 seconds; Off = 15 seconds).

Modulation & Purge DIP Switch Settings

Modulation and purge models of the Veri-Flame use all of the eight DIP switches, as illustrated in Figure 3.2 on page 13. They are as follows:

SW1: Recycling mode selection (On = Recycling; Off = Non-recycling)

SW2: Pilot selection (On = Intermittent, where pilot remains on during burner cycle; Off = Interrupted, where pilot valve closes after main burner is established).

SW3: Trial-for-ignition (TFI) range selection (**For 5602/5603 units:** On = 10 seconds; Off = 5 seconds. **For 5605 units:** On = 10 seconds; Off = 15 seconds).

SW4 through 7: Purge time selection. Total purge time is the sum of each switch selected.

SW8: Post purge selection. (On = 15 second post purge).

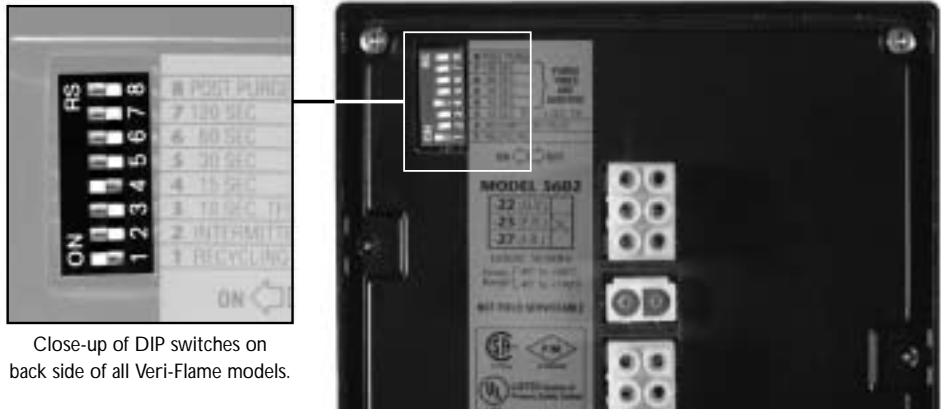

Figure 3.1 DIP Switch Location





Close-up of DIP switches on back side of all Veri-Flame models.

Figure 3.2 DIP Switch Labels with Selections



No Purge Models

8	} NOT USED
7	
6	
5	
4	
3	10 SEC. TFI / 5 SEC. TFI
2	INTERMITTENT PILOT
1	RECYCLING
ON <input type="checkbox"/> OFF <input type="checkbox"/>	
MODEL 5602	
-32 (U.V.)	
-33 (F.R.)	
-37 (I.R.)	
120VAC 50/60Hz Temp. \bar{f} 40° to +60°C Range \bar{L} 40° to +140°F	
NOT FIELD SERVICEABLE	
 	
MADE IN	



8	} NOT USED
7	
6	
5	
4	
3	10 SEC. TFI / 5 SEC. TFI
2	INTERMITTENT PILOT
1	RECYCLING
ON <input type="checkbox"/> OFF <input type="checkbox"/>	
MODEL 5603	
-32 (U.V.)	
-33 (F.R.)	
-37 (I.R.)	
205-265VAC 50/60Hz Temp. \bar{f} 40° to +60°C Range \bar{L} 40° to +140°F	
NOT FIELD SERVICEABLE	
MADE IN	

8	} NOT USED
7	
6	
5	
4	
3	10 SEC. TFI / 15 SEC. TFI
2	INTERMITTENT PILOT
1	RECYCLING
ON <input type="checkbox"/> OFF <input type="checkbox"/>	
MODEL 5605	
-32 (U.V.)	
-33 (F.R.)	
-37 (I.R.)	
120VAC 50/60Hz Temp. \bar{f} 40° to +60°C Range \bar{L} 40° to +140°F	
NOT FIELD SERVICEABLE	
 	
MADE IN	



Purge Models

8	POST PURGE	} PURGE TIMES ARE ADDITIVE
7	120 SEC.	
6	60 SEC.	
5	30 SEC.	
4	15 SEC.	
3	10 SEC. TFI / 5 SEC. TFI	
2	INTERMITTENT PILOT	
1	RECYCLING	
ON <input type="checkbox"/> OFF <input type="checkbox"/>		
MODEL 5602		
-22 (U.V.)		
-23 (F.R.)		
-27 (I.R.)		
120VAC 50/60Hz Temp. \bar{f} 40° to +60°C Range \bar{L} 40° to +140°F		
NOT FIELD SERVICEABLE		
 		
MADE IN		

8	POST PURGE	} PURGE TIMES ARE ADDITIVE
7	120 SEC.	
6	60 SEC.	
5	30 SEC.	
4	15 SEC.	
3	10 SEC. TFI / 5 SEC. TFI	
2	INTERMITTENT PILOT	
1	RECYCLING	
ON <input type="checkbox"/> OFF <input type="checkbox"/>		
MODEL 5603		
-22 (U.V.)		
-23 (F.R.)		
-27 (I.R.)		
205-265VAC 50/60Hz Temp. \bar{f} 40° to +60°C Range \bar{L} 40° to +140°F		
NOT FIELD SERVICEABLE		
MADE IN		

8	POST PURGE	} PURGE TIMES ARE ADDITIVE
7	120 SEC.	
6	60 SEC.	
5	30 SEC.	
4	15 SEC.	
3	10 SEC. TFI / 15 SEC. TFI	
2	INTERMITTENT PILOT	
1	RECYCLING	
ON <input type="checkbox"/> OFF <input type="checkbox"/>		
MODEL 5605		
-22 (U.V.)		
-23 (F.R.)		
-27 (I.R.)		
120VAC 50/60Hz Temp. \bar{f} 40° to +60°C Range \bar{L} 40° to +140°F		
NOT FIELD SERVICEABLE		
 		
MADE IN		

Modulation Models

8	POST PURGE	} PURGE TIMES ARE ADDITIVE
7	120 SEC.	
6	60 SEC.	
5	30 SEC.	
4	15 SEC.	
3	10 SEC. TFI / 5 SEC. TFI	
2	INTERMITTENT PILOT	
1	RECYCLING	
ON <input type="checkbox"/> OFF <input type="checkbox"/>		
MODEL 5602		
-42 (U.V.)		
-43 (F.R.)		
-47 (I.R.)		
120VAC 50/60Hz Temp. \bar{f} 40° to +60°C Range \bar{L} 40° to +140°F		
NOT FIELD SERVICEABLE		
 		
MADE IN		

8	POST PURGE	} PURGE TIMES ARE ADDITIVE
7	120 SEC.	
6	60 SEC.	
5	30 SEC.	
4	15 SEC.	
3	10 SEC. TFI / 5 SEC. TFI	
2	INTERMITTENT PILOT	
1	RECYCLING	
ON <input type="checkbox"/> OFF <input type="checkbox"/>		
MODEL 5603		
-42 (U.V.)		
-43 (F.R.)		
-47 (I.R.)		
205-265VAC 50/60Hz Temp. \bar{f} 40° to +60°C Range \bar{L} 40° to +140°F		
NOT FIELD SERVICEABLE		
MADE IN		



Function Summary

4

INTRODUCTION

This section describes the features of the Veri-Flame. It is broken into three categories: Standard features, Optional features and the LED Indicator Lights on the front cover. Refer to Figure 5.5 for sequence diagrams.

STANDARD FEATURES

The following function features are standard on the Veri-Flame models as noted:

Interlocks and Limit Switch Input (Terminal 7)

This input is considered the normal operation control or run input to the Veri-Flame system. Interlocks are generally pressure or temperature switches which, when activated, start the burner. Limit switches are generally pressure, temperature and other switches which, when activated, stop the burner. The interlocks and limit switches are wired in series. A break in this circuit will shut the burner down, but will not produce an alarm.

Combustion Air Switch Input (Terminal 6)

For purge and modulation models: This input is for monitoring the combustion air switch separately from other interlocks and limits. The Veri-Flame checks the air flow switch input is open before start-up, closed during operation, and open again at burner shutdown, thus preventing operation with an air switch that is defective, maladjusted or jumped. This input has about a 2 second delay to filter out and ignore a momentary interruption.

The input will be proven open before start-up and after shutdown. If the input is improperly powered before the fan output is energized, the system error light will blink. The input must de-energize within 30 seconds or the Veri-Flame will lockout.

After the fan output has energized, the air switch input must be made within 10 seconds. If not proven, then the system will lockout, the alarm output and the air failure light will come on. However, if the unit has the optional air switch input hold feature, the sequence is held indefinitely without causing a lockout. When the air switch input is made, then the sequence continues.

If the air switch opens during the main firing cycle, the system will either lockout or recycle, depending on the DIP switch recycle selection.

Main Fuel Valve Closed Switch (Terminal V)

Purge and No-Purge models: the Veri-Flame can be interlocked with the main valve closed switch. This feature checks the switch position before start-up and after shutdown to insure proper valve operation when the jumper on the base is cut.

Low Fire Start

For modulation models: when wired, the system checks for the low fire start position prior to light-off.

Main Fuel Valve Closed/ High Fire Purge Check (Terminal D)

Recycle Mode

Pilot Test Mode



Test Mode
(Button In)

Run Mode
(Button Out)

Interrupted or Intermittent Pilot

Post Purge

Spark, Pilot Flame & Main Flame Separation

System Errors & Lockout Conditions

For modulation models: This feature is enabled when the jumper on the base is cut. The system checks that the high fire position switch and the main valve closed switch are both made at the end of the high fire purge.

For all models: when selected, the Veri-Flame will restart the sequence after flame or air failure. The recycle mode allows the system to re-initiate the start-up sequence automatically provided the main burner has been operating for at least 35 seconds. If the pilot flame fails to light during recycling, the system will lock out and annunciate a pilot flame fail. If the recycle is successful and the main burner is operational for at least 35 seconds, the system is ready for another recycle. At no time will the system recycle in the event of pilot flame fail.

For all models: this mode is entered by depressing the TEST/RESET button on the front cover. In the pilot test mode, the Veri-Flame will hold the sequence once the pilot flame is established (i.e., the main valve is not energized). When in the pilot test mode, the green "Interlocks Closed" light **blinks**.

To exit the pilot test mode, simply push the TEST/RESET button again and the Veri-Flame will exit the pilot test mode (the green "Interlocks Closed" light **stops blinking but remains lit**) and restart the sequence.

For all models: pilot mode is selected using the DIP switch SW2. An interrupted pilot shuts off 10 seconds after the main valve opens. An intermittent pilot continues during the entire main flame firing cycle.

For purge and modulation models: post purge is enabled by DIP switch SW8. A post purge maintains the combustion air fan output for 15 seconds after the interlocks and limit switch input have opened.

For all models: during the trial for ignition period (TFI), the pilot valve and ignition coil remains energized. At the end of the TFI, the pilot flame remains on and the ignition coil is de-energized. After a five second delay to prove the pilot flame, the main gas valve is energized.

A **system error** (illuminated by the red "System Error" LED on the front cover) prevents gas ignition. The unit will continue its sequence after the error is cleared. A **lockout condition** energizes the alarm output and de-energizes the gas valve and ignition outputs. The unit must be reset to clear the alarm and start the sequence. To reset, the button must be pressed twice so that the button is in the out position.

The following system errors result in immediate lockout conditions:

- 1) Wiring error which puts external voltage on the output terminals (**for all models**).
- 2) Welded internal contacts or other malfunctions in the Veri-Flame (**for all models**).
- 3) Main fuel valve (**for all models**)—open after cycle shutdown or before start-up. The system error light blinks twice and then remains on. The fan output terminal 8 will energize.

System Errors & Lockout Conditions (Continued)

- 4) Low fire fail (**for modulating model**)—low fire switch open prior to trial for ignition.
- 5) High fire fail (**for modulating model**)—high fire switch is not closed at the end of high fire purge.

The following situations will result in a lockout condition:

- 6) Air failure (**for purge and modulation models**) – loss of combustion air anytime during the operational cycle. The Air Failure LED will be on for this condition. (See “Recycle Mode”).
- 7) Pilot flame fail (**for all models**) loss of flame during the trial for pilot ignition period. The Flame Failure LED will be on for this condition.
- 8) Main flame fail (**for all models**) loss of flame during the main burner trial for ignition or run period (recycling not selected). The Flame Failure LED will be on for this condition.

The following result in lockout conditions after 30 seconds, the system error light blinks about 14 times and then remains on:

- 9) If a flame is detected out of sequence, which may be caused by:
 - a) a faulty scanner (**for all models**);
 - b) electrical interference on the sensor wiring (**for all models**);
 - c) a flame exists in the burner or in the line of sight of a scanner, due to a gas leak, product fire or other condition (**for all models**).
- 10) Air flow switch closed before start-up (**for purge and modulation models**).

High to Low Fire Purge Modulation Capability with High to Low Fire Position Switch Interlocks

For modulation models: the modulation feature incorporates a high fire purge time and a low fire purge time into the purge sequence. This feature allows the Veri-Flame to sequence internal dry contacts which can be used by the customer requiring a high fire purge of the combustion chamber before ignition.

The high fire and low fire purge times are selectable by means of DIP switches (see Section 3, “DIP Switch Settings” on page 12):

SW4 15 seconds	SW6 60 seconds
SW5 30 seconds	SW7 120 seconds

The selected times are additive and apply to both the high fire and low fire purge times (that is, high and low fire times are always identical).

The modulation terminals will sequence as follows:

Sequence Step	Internal Contact Connections	
Power Off	Terminal 10 (Common)	Terminal 11 (Auto)
Power On, Limits Open	Terminal 10 (Common)	Terminal 12 (Low Fire)
Purge To High Fire	Terminal 10 (Common)	Terminal 13 (High Fire)
Purge To Low Fire	Terminal 10 (Common)	Terminal 12 (Low Fire)
Automatic Modulation	Terminal 10 (Common)	Terminal 11 (Auto)
Alarm and Lockout	Terminal 10 (Common)	Terminal 12 (Low Fire)

The Automatic step occurs when the burners are operating and allows the burner firing rate to be controlled by an automatic temperature controller.

OPTIONAL FEATURES

Air Switch Input Hold

The following features are available on select models, or when optional equipment is purchased.

For purge/modulation models: holds the sequence indefinitely until air switch input is confirmed without affecting the air failure function and causing a lockout.

Remote Display & Power Supply

Two models of remote display are available. The model 5602DB operates on 24VDC and has no keypad. The model 5602DBP operates on 120VAC and has a keypad for reset function. The display is door panel mounted and features a liquid crystal display in a ¼ DIN housing. The unit connects to the Veri-Flame by a cable to the flame signal test jack, and receives a serial communication on each sequence state change. The display incorporates the following functions:

- 1) Provides status messages for the Veri-Flame sequence (see section 9).
- 2) Indicates lockout conditions when they occur, as well as the amount of time into the sequence when the lockout occurred (see section 9).
- 3) Provides continuous monitoring of the burner's flame signal strength and run time during main burner operation.

Manual Reset on Power Outage

This optional feature requires a reset on initial application of power or after an interruption of power. The system error light blinks rapidly (about 4 times per second) and a remote display will show "PUSH RESET TO START". The reset button must be pressed in and out to start

STATUS LIGHTS & PUSH-BUTTON

All of the status lights and the TEST/RESET push-button are located on the front cover of the Veri-Flame. This section describes their respective functions.

Interlocks Closed

For all models: this green LED illuminates when the operation limits are made. These limits are wired in series to terminal 7. This input becomes energized to begin the burner sequence. When in the test mode, this LED blinks (see "Pilot Test Mode" on page 15).

Air Failure

For purge and modulation models: this red LED illuminates whenever combustion air is lost during the operational cycle of the Veri-Flame.

System Error

For all models: this red LED illuminates when a system error is detected (see "System Errors & Lockout Conditions" on pages 15-16).

Flame Failure

For all models: this red LED illuminates when a pilot or main flame fails.

Low Fire

For modulation models: this yellow LED illuminates during the low fire period of the purge cycle.

High Fire

For modulation models: this red LED illuminates during the high fire period of the purge cycle.

Auto

For modulation models: this green LED illuminates during the automatic period which occurs 20 seconds after the main valve is energized.

Test/Reset

For all models: this push-button is used to activate the pilot test mode or to reset the Veri-Flame unit.

Flame Signal

For all models: this red LED is located behind the signal test port and illuminates when a flame signal is present.

System Installation

5

INTRODUCTION

In this section, the necessary procedures are detailed to integrate a Veri-Flame into a burner system; Figures 5.1 and 5.2 illustrate the various terminal strips mentioned.



Note:

Shut off the power supply before the Veri-Flame is removed or replaced from the base.



Caution:

Installation and maintenance must conform with the National Electrical Code and all other national and local codes and authorities having jurisdiction. Flame monitoring systems must be installed by a qualified, licensed technician.

Interlocks and Limit Switch Input

Wire external interlock, control, and limit switches in series to this input. Guard against induced voltage levels to wiring connected to this input. In some extreme wiring runs, reduction of induced voltages may require a load (relay or light) connected to terminal 7 to avoid system error lockouts. This input is the power source for the valve and ignition output terminals. Be sure all switches wired to this input can handle the current required by the total of all loads connected to terminals 3, 4, and 5.

Combustion Air Switch Input

For purge and modulation models: Wire any switches and contacts in series to this terminal for proving air flow function and relating to the air failure light. Power must not be immediately present at terminal 6 when power is first applied to terminals 1 or 7.

If this terminal is not used, place a jumper between the combustion blower output (terminal 8) and the air switch input (terminal 6).

If the combustion air blower is controlled outside of the Veri-Flame system, then a three way solenoid valve must be connected between the air switch port and the blower sensing port. The valve de-energized state should vent the switch to ambient pressure. The energized state then connects the air switch to the blower sensing port. Power the valve from the blower output terminal 8. If accepted by local codes, the air switch could be wired between the combustion blower output and the air switch input. Connecting the air switch in this manner will satisfy the open contact (air short) check on the switch.

Ignition Wiring

Route ignition wiring a sufficient distance from all sensors and other low voltage wiring to avoid electrical interference, which may cause erratic operation of the Veri-Flame system. Keep the high voltage wire run from the ignition transformer as short as possible. The best condition is to mount the ignition transformer close to the burner and keep a low impedance path from the burner ground to the case of the transformer. Make sure the high voltage lead and ground return paths do not create a loop antenna around the Veri-Flame and sensor wiring.

Low Fire Input

For modulation models: it is possible to wire the system for checking low fire start position prior to pilot ignition. To use this feature, the low fire start switch must be connected between terminal 3 and the pilot valve (see Figure 5.2). On direct spark burners, a by-pass contact must be wired around the low fire switch, see relay and contact CR in Figure 5.3.

Main Valve Closed Switch

The system can be wired to check for the main valve closed switch on the main gas valve prior to start-up and after the end of the burner cycle.

For purge and no purge models: the main valve closed switch must be connected to Terminal V and **the jumper in the base must be cut** (see Figure 5.4 on page 22).

For modulation models: the main valve closed switch must be wired in series between the air flow switch and the high purge damper switch (see Figure 5.1 on page 20). **To use this feature, the jumper in the base must be cut.**

High Purge Input

For modulation models: the system can be wired to check for high purge position during the high fire purge portion of the sequence. **To use this feature, the red jumper in the base must be cut** and the high purge position switch must be connected from terminal 6 to D. If this feature is not used, the jumper in the base remains intact or a jumper must be installed between terminals 1 and D. Please note that the yellow jumper on the base has no effect whether cut or intact.

Remote Reset

This feature permits remote mounting of a switch to reset the Veri-Flame. To use this feature, a normally closed remote reset switch must be wired so power is interrupted to terminal 1. When it is depressed or actuated, the connection to terminal 1 is momentarily interrupted and resets the Veri-Flame.

Remote Display & Power Supply

Identify the model of remote display (see page 11) and wire according to figure 5.3. Mount through a ¼ DIN cutout using the two supplied brackets in either the top and bottom or the side slots. Locate the display and wiring to minimize electrical interference. Applying and disconnecting the display power supply should coincide with power to terminal 1 of the Veri-Flame. Use the appropriate cable (Eclipse part #20318) to connect to the test jack and to the S2 terminal of the Veri-Flame wiring base. Do not attempt to parallel the test jack signal to other devices when using a remote display. The LCD display contrast can be adjusted on the back with a small blade screwdriver.

Figure 5.1 No Purge and Purge Wiring Diagrams

No Purge Models

Purge Models

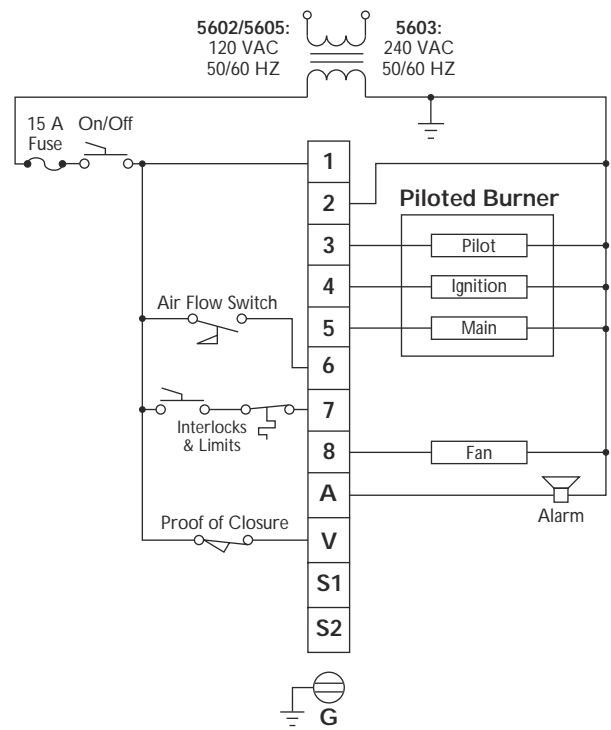
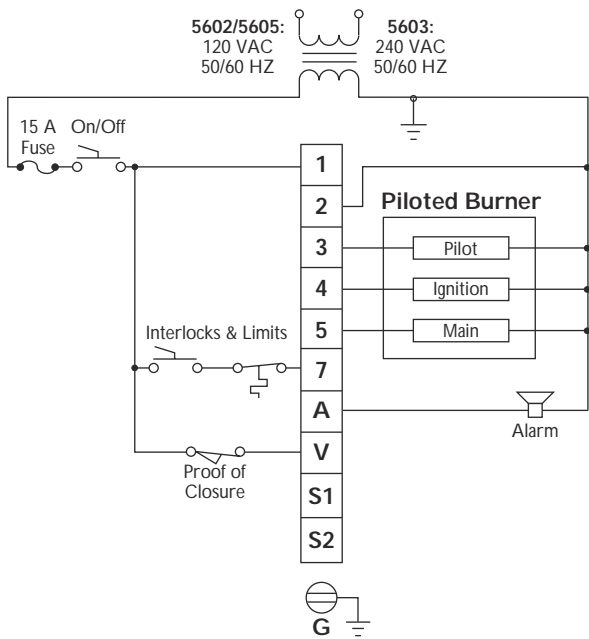

Figure 5.2 Modulation Wiring Diagram

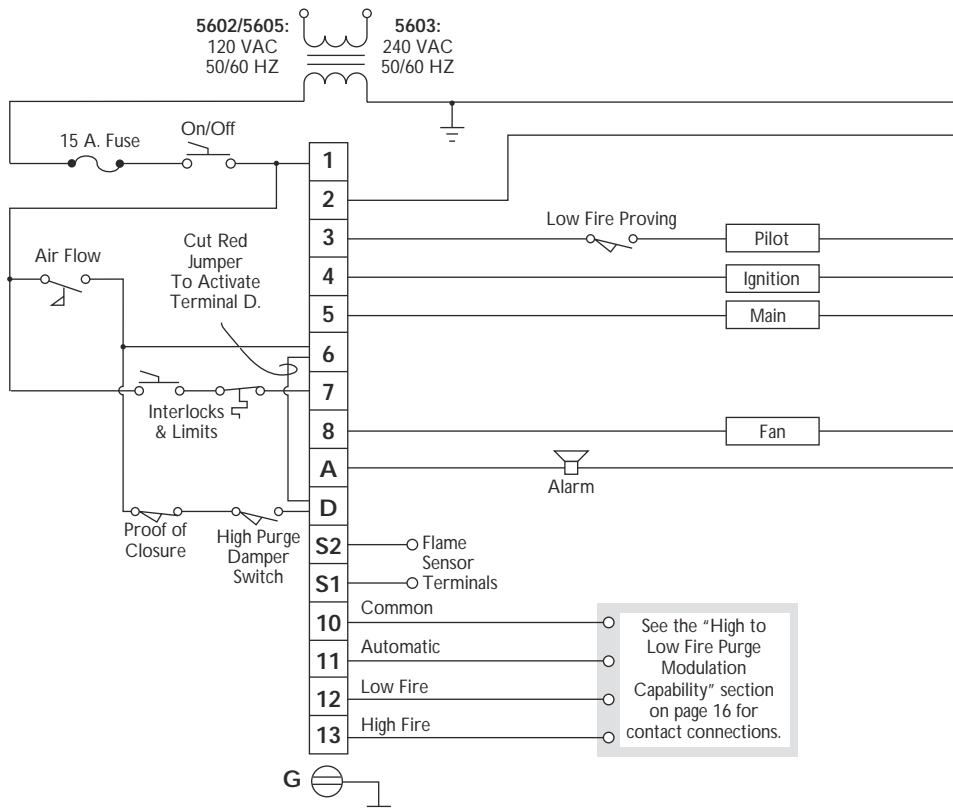
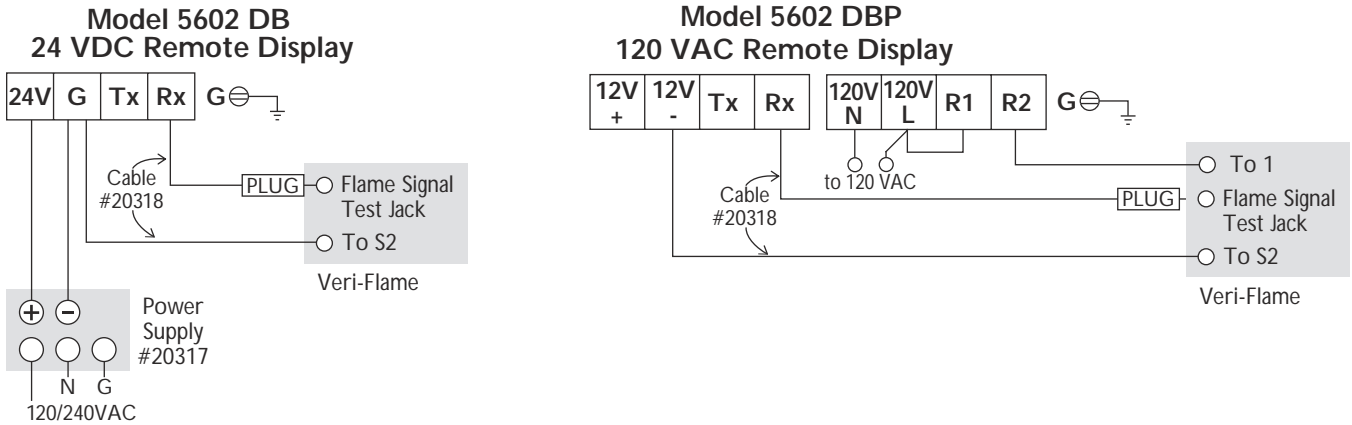
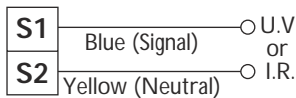

Figure 5.3 Typical Connections For All Models



U.V./I.R.



Solid State U.V./I.R.

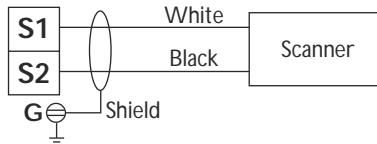

Flame Rod

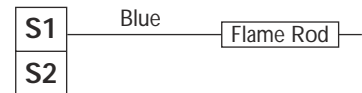

**Self Check U.V. 5602-91
(Requires 5602-91-7 cable)**

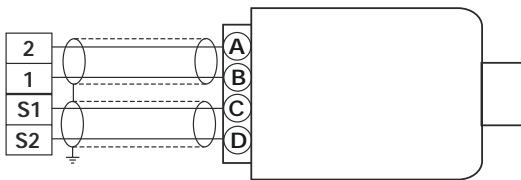

Direct Spark

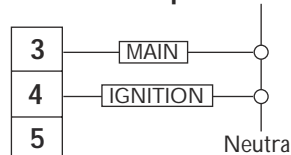

Note: Intermittent pilot must be selected, DIP-SW2 = ON

**Direct Spark with
Low Fire Start**

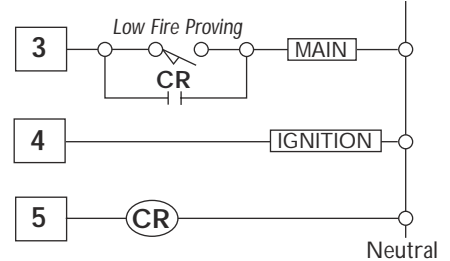

Note: Intermittent pilot must be selected, DIP-SW2 = ON
CR is a control relay used to bypass the low fire switch after the burner is lit.



Notes for Figures 5.1, 5.2 & 5.3:

1. Ground, shielding and conduit must not be connected to terminal S2.
2. Control circuit wires must meet 90°C (194°F) specification minimum and must be No. 16 AWG or larger and in accordance with all applicable codes.
3. Flame sensor wires must be individually run in their own separate conduit; flame sensor wires CANNOT be run together in a common conduit or wire-way (See Section 6).
4. Flame signal should read between 4 and 10VDC with a digital volt meter. Drop off is approximately 4.0 VDC. Positive test jack point is on the cover marked "Flame Signal" with negative point being the ground.
5. Purge time, TFI, intermittent/interrupted pilot, and recycle/non-recycle selections are made with a DIP switch located on the rear plate of the control unit.
6. Neutral must be grounded.

Figure 5.4 Purge and No Purge Bases

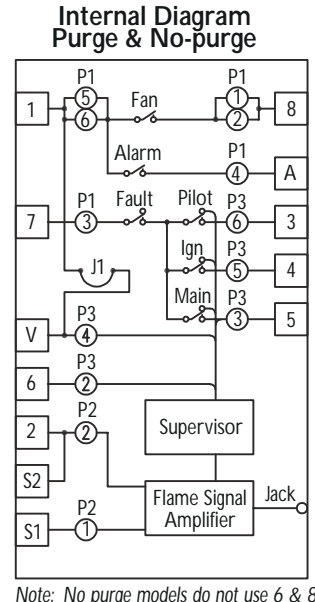
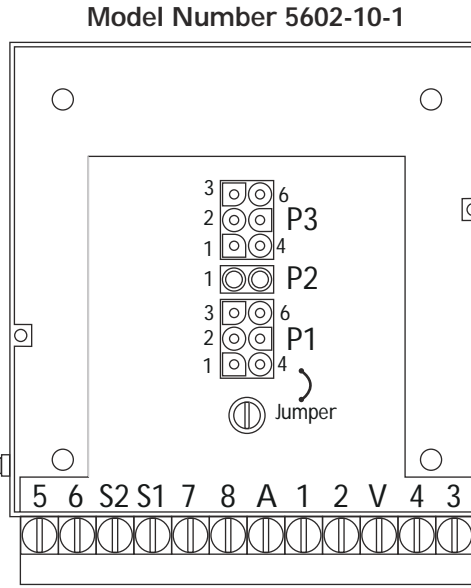
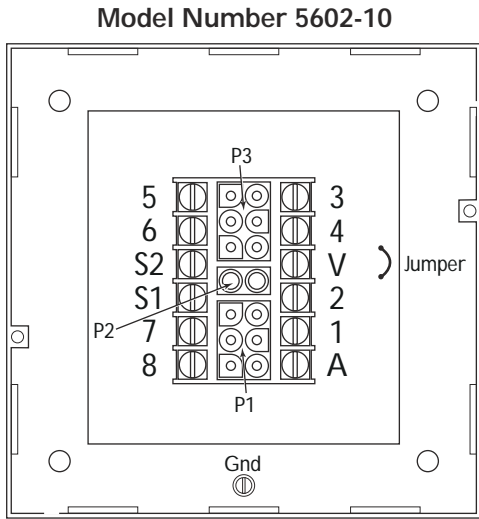

NOTE: Ground Terminal not present in plastic base.

Modulating Base

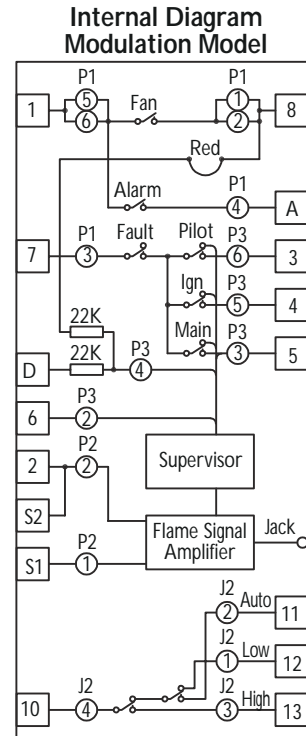
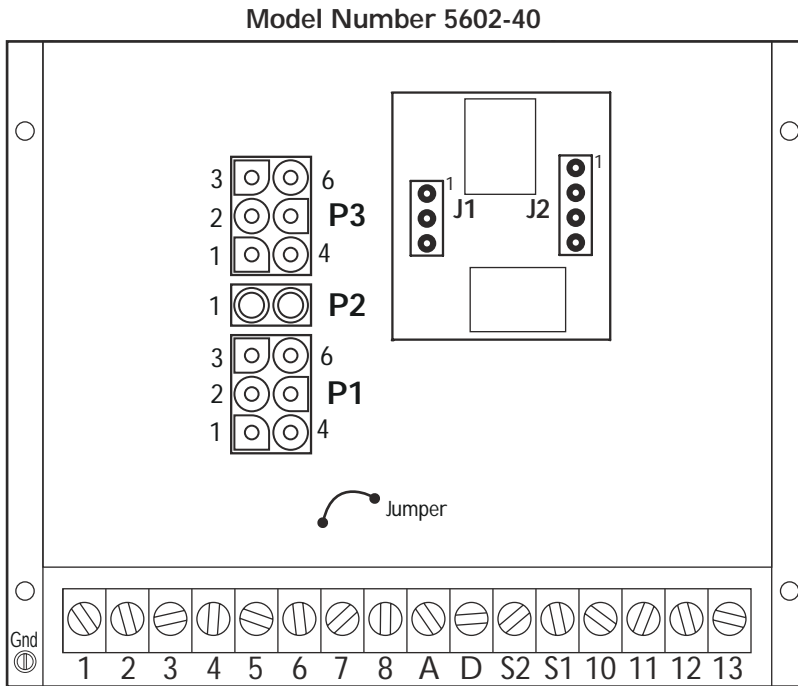
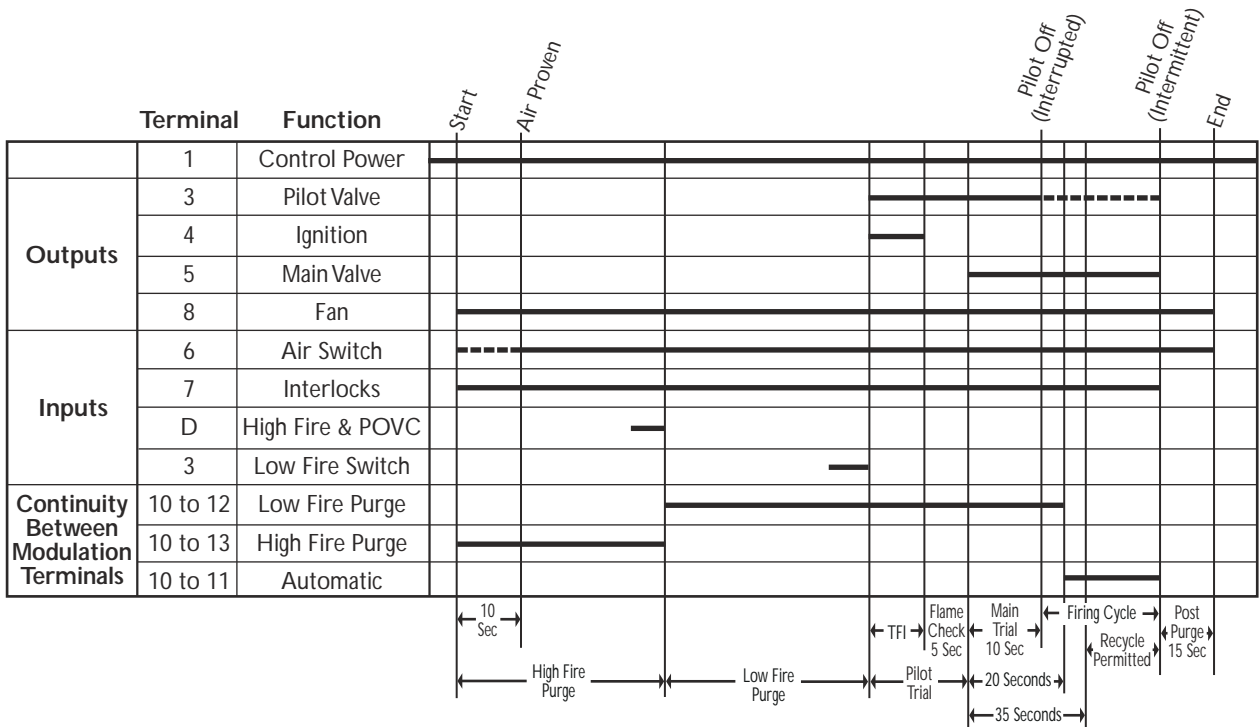
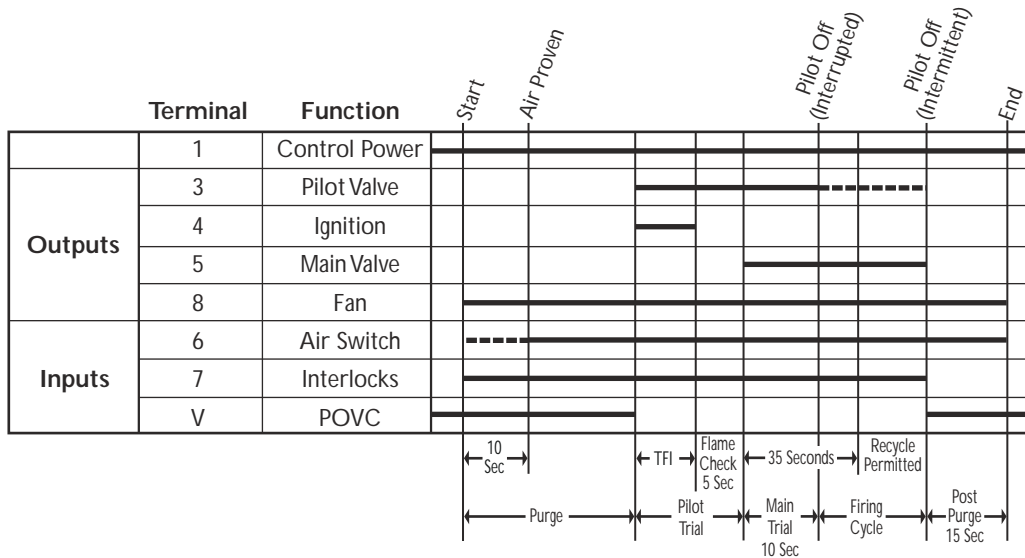
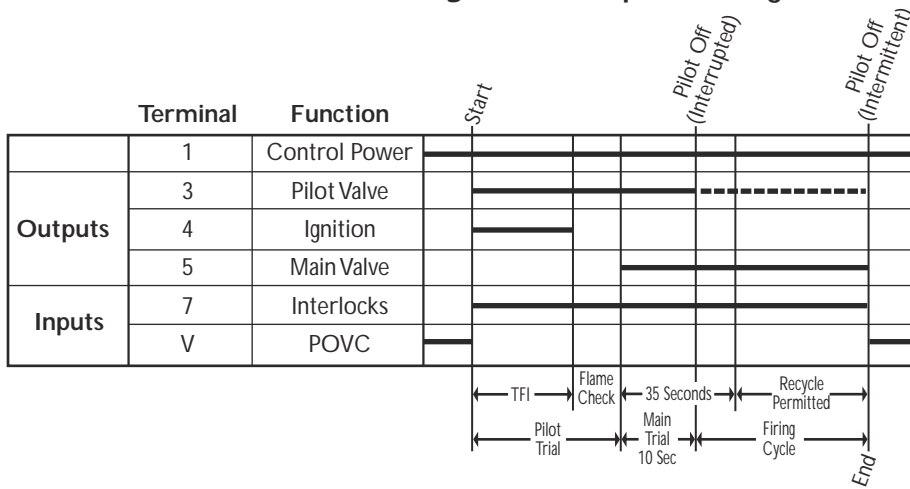

Figure 5.5 Sequence Diagrams



Sensor Installation

6

INTRODUCTION

This section describes the proper wiring, installation and sighting considerations for all sensors that can be used with a Veri-Flame.



Warning

Incorrect sensor installation may cause the sensor to generate a false flame signal, possibly resulting in the collection of unburned fuel in the combustion chamber. This unburned fuel creates the potential for explosions which can result in injuries, death and property damage. Be certain that the flame sensor detects acceptable pilot and main flames only.

Sensor Wiring

Route sensor wiring a sufficient distance from ignition and other high voltage or high current wiring to avoid electrical interference. Interference from ground currents, nearby conductors, radio-frequency emitters (wireless devices), and inverter drives can induce false flame signals. Shielded cables can help reduce interference with the shield connected to ground at the control end only. The wire type and its capacitance (picofarads or microfarads) to ground may cause low signal problems, so a grounded shield may decrease the signal due to the cable's internal capacitance. Multiple U.V. tube-type sensor leads run together without shielding may interfere or "cross talk", so the shield or flexible armor must be grounded to prevent this situation. For flame rod sensor runs approximately 100 feet (30 meters) or greater, use Eclipse part number 21741 coax cable. To achieve the maximum wiring distance, the shield should not be grounded (keep in mind that an ungrounded shield provides less protection against electrical interference).



Note:

Unshielded sensor wiring must not be run in common with other wires; it must be run in separate conduit. Use #14 to #18 AWG wire suitable for 90°C (194°F) and 600 volt insulation. Multiple unshielded flame sensor wiring must not be run together in a common conduit or wireway. Multiple shielded flame sensor cables can be run in a common conduit.

Flame Rods

Flame rods should be used only on gas burners. They accumulate soot on oil burners, causing nuisance shutdowns and unsafe operating conditions.

See the burner manufacturer's literature for flame rod mounting location. When installing flame rods, please consider the following:

Figure 6.1 Flame Rod Position

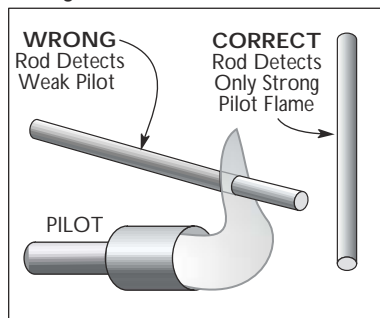

Scanners



Warning

Use only Eclipse scanner models as listed in the Illustrated Parts List at the end of this document.

- 1) Keep the flame rod as short as possible and at least 13 mm (1/2") away from any refractory.
- 2) Position the rod into the side of both the pilot and main flames, preferably at a descending angle to minimize drooping of the flame rod against burner parts, as shown in Figure 6.1. Flame rod position must adequately detect the pilot flame at all burner draft conditions. Extend the rod 13 mm (1/2") into nonluminous flames, such as blue flames from burning an air/gas mixture. For partially luminous flames, such as atmospheric air/gas mixtures, place the rod at the edge of the flame.
- 3) Provide a burner/flame grounding area that is at least four times greater than the flame rod area contacting the flame. The flame rod/burner ground ratio and position of the rod in the flame may need adjustment to yield maximum flame signal strength.
- 4) Ignition interference from the spark plug may increase or decrease the flame signal strength. Reversing the ignition transformer primary leads may reduce this effect. Changing the spark gap or adding grounding area between the flame rod and spark plug may eliminate the interference.

When installing scanners, please consider the following:

- 1) Position the scanner within 457 mm (18") of the flame. Consult factory for longer distances.
- 2) Bushing threads are 1/2 inch F.N.P.T. for all scanner models except 5602-91 which has 1 inch F.N.P.T. bushing threads.
- 3) The ambient temperature limits of each scanner varies; check the literature for the specific scanner model. For higher temperatures, use Eclipse heat block seal 23HBS for 1/2" N.P.T. scanners and if necessary, add cooling purge air.
- 4) An optional magnifying lens may also be used to increase the flame signal strength in difficult sighting situations.

Scanner Sighting Considerations

Figure 6.2 U.V. Scanner Sighting

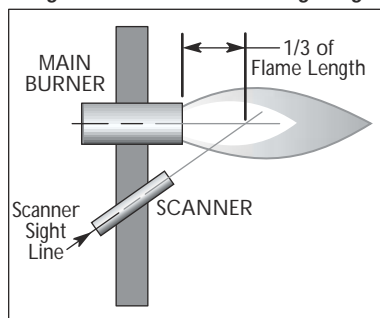

Aim scanners at the third of the flame closest to the burner nozzle, as shown in Figure 6.2 (oil flames typically have less UV radiation in the outer flame). The scanner should view the intersection of the pilot and main flames. When sighting scanners, please consider the following:

- 1) Sight the scanner away from the ignition spark. Sighting the spark or its reflections from burner internals can cause nuisance shutdowns during burner ignition. If necessary, use a scanner orifice to reduce spark pickup.
- 2) Do not allow the scanner to detect a pilot flame that is too small to ignite the main burner.
- 3) Perform a minimum pilot test when installing or adjusting any pilot or main burner system; see "Minimum Pilot Test" on page 26.
- 4) I.R. scanner model 5600-92B is ideal for oil flame applications. When used, aim the I.R. scanner at the outer oil flame for flickering detection.



Test Procedures

7

INTRODUCTION

This section describes the test procedures that must be performed after installation to insure that the Veri-Flame is operating properly; these procedures are mandatory.

Flame Signal Strength

Insert the positive probe of a 0-15 VDC, digital volt meter into the test point on the front cover of the Veri-Flame; connect the negative probe to ground. A good flame signal strength will read between 6 and 11VDC; anything below 4 VDC is inadequate. Also, the red LED inside the test point illuminates when a flame signal is indicated.

Minimum Pilot Test

Run the following test procedures to ensure that the sensor will not detect a pilot flame too small to reliably light the main flame:

- 1) Manually shut off the fuel supply to the burner, but not to the pilot.
- 2) Start the system normally.
- 3) To enter the pilot test mode, depress the test/reset button located in the lower right corner on the front cover.
- 4) The control will hold the operating sequence at the pilot flame step. Measure signal strength as described above.
- 5) Reduce pilot fuel until the flame relay drops out. Increase pilot fuel until the flame signal is greater than 4VDC, and flame relay just manages to pull in. This is the minimum pilot. If you don't think this flame will be able to safely light the main burner, realign the sensor so that it requires a larger pilot flame and repeat steps 2 through 5.
- 6) Push the test/reset button located in the lower right corner on the front cover to exit the test mode (reset) and begin the normal start-up sequence again.
- 7) When the sequence reaches the main flame trial for ignition, smoothly restore the fuel supply to the burner. If the main burner does not light within five seconds, immediately shut off the burner supply to shut down the system. Realign the sensor so that it requires a larger pilot flame. Repeat steps 1 through 6 until the main burner lights off smoothly and reliably.

Pilot Flame Failure Test

- 1) Manually shut off the fuel supply to the pilot and the main burner.
- 2) Place system in pilot test mode (please refer to page 15).
- 3) Start the system normally. The controller should lock out*; if it doesn't, then the controller is detecting a false flame signal (see Section 6). Find the problem and correct it before resuming normal operation.

Main Flame Failure Test (For Interrupted Pilot Systems)

- 1) Manually shut off the fuel supply to the main burner but not to the pilot.
- 2) Start the system normally. This should ignite the pilot and lock out* after pilot interruption. If the system does not lock out, the controller is detecting a false flame signal (see Section 6). Find the problem and correct it before resuming normal operation.

Spark Sighting Test

- 1) Manually shut off the fuel supply to the pilot and the main burner.
- 2) Start the system normally.
- 3) Measure the flame signal as described in "Flame Signal Strength" in this section.
- 4) If a flame signal greater than 4VDC is measured for more than three seconds during the trial for ignition, then the sensor is picking up a signal from the spark plug; see "Sensor Wiring" on page 24.

Limits & Interlock Tests

Periodically check all interlock and limit switches by manually tripping them during burner operation to make sure they cause the system to shut down.



Warning

Never operate a system that is improperly adjusted or has faulty interlocks or limit switches. Always replace faulty equipment with new equipment before resuming operation. Operating a system with defective safety equipment can cause explosions, injuries, and property damage.

* Indicated by the illuminated red "Flame Failure" LED on the Veri-Flame front cover.

Maintenance & Troubleshooting

8

INTRODUCTION

This section is divided into two parts:

- The first part describes the maintenance procedures.
- The second part describes troubleshooting procedures, from identifying problems to interpreting the operating conditions by the lit LEDs on the front cover.

MAINTENANCE

Preventative maintenance is the key to a reliable, safe and efficient system. The core of any preventive maintenance program is a list of periodic tasks.

In the paragraphs that follow are suggestions for a monthly list and a yearly list.



Note:

The monthly list and the yearly list are an average interval. If your environment is dirty, then the intervals may be shorter.



Caution:

Turn off power before disconnecting or installing sensors, controls or modules.

Monthly Checklist

1. Inspect flame-sensing devices for good condition and cleanliness. Keep scanner lenses clean with a soft, damp cloth, since small amounts of dust will measurably reduce the flame signal strength. Wash the flame rod electrode and insulator with soap and water, then rinse and dry thoroughly.
2. Test all the alarm systems for proper signals.
3. Check ignition spark electrodes and check proper gap.
4. Test interlock sequence of all safety equipment as described on page 27: manually make each interlock fail, noting what related equipment closes or stops as specified by the manufacturer.
Test flame safeguard by manually shutting off gas to the burner.

Yearly Checklist

1. Test (leak test) safety shut-off valves for tightness of closure.
2. Test pressure switch settings by checking switch movements against pressure setting and comparing with actual impulse pressure.
3. Visually check ignition cable and connectors.
4. Make sure that the following components are not damaged or distorted:
 - the burner nozzle
 - the spark plugs
 - the flame sensors
 - the flame tube or combustion block of the burner

TROUBLESHOOTING

PROBLEM	POSSIBLE CAUSE	SOLUTION
Cannot initiate start sequence	Main valve is not closed.	Check main valve closed switch. No voltage on V (or D).
	Air pressure switch has not made contact.	Check air pressure switch adjustment. Check air filter. Check blower rotation. Check outlet pressure from blower. No voltage on 6 after 8 is on.
	High gas pressure switch has tripped.	Check incoming gas pressure; adjust gas pressure if necessary. Check pressure switch setting and operation. No voltage to 7.
	Low gas pressure switch has tripped.	Check incoming gas pressure; adjust gas pressure if necessary. Check pressure switch setting and operation. No voltage to 7.
	Malfunction of flame safeguard system such as a shorted-out flame sensor or electrical noise in the sensor line.	Have qualified electrician investigate and rectify.
	Purge cycle not completed.	Check switch settings. Check air switch.
	Main power is off.	Make sure power is on to control system.
	No power to control unit.	Call qualified electrician to investigate.
Scrambled messages on remote display.	Electrical interference.	Check grounding in system. Separate communication cable. Move ignition circuit.
"UNSAFE AIR SHORT" message appears on display.	Improperly adjusted air switch. Air switch either shorted or wired wrong.	Check air switch settings. Check wiring to air switch.
Burner flame fails but no flame failure indication occurs.	A faulty scanner.	Check scanner as explained in checklists in "Maintenance" portion of this Section.
	Improperly connected sensor wires.	Check wiring diagram on page 20 or 21 as well as appropriate sensor information in Section 6.
	Electrical interference from other current carrying wires.	Check Note information on page 24 regarding sensor wiring.
Voltage reading greater than 15VDC at "Test Point" on Veri-Flame faceplate.	Improper grounding.	Check grounding of neutral at control power transformer.

LED STATUS

This section describes the status of operating conditions based on the LED or combination of LEDs which are lit on the front cover of each Veri-Flame model.

Table 8.1 LED Status & Conditions for Veri-Flame No Purge Models

LED(s) LIT	POSSIBLE CAUSES
INTERLOCKS CLOSED	1) The interlocks are closed (normal operation), power on terminal 7.
SYSTEM ERROR	<ol style="list-style-type: none"> 1) The flame detected is out of sequence, flame signal light is on. 2) The sensor is "runaway", flame signal light is on. 3) Inductance is detected on sensor wires, flame signal light is on. 4) Voltage wired into terminals 3, 4 or 5. 5) Internal relay contacts welded. 6) Internal controller failure. 7) Main valve closed switch defective, no power to V.
FLAME FAILURE	<ol style="list-style-type: none"> 1) Pilot flame is not established in selected TFI. 2) Main flame is not established in selected TFI. 3) Main flame fails within 35 seconds of TFI. 4) Flame failed during operation in non-recycle mode. 5) Flame failed 35 seconds after TFI and was not established after try in recycle mode.

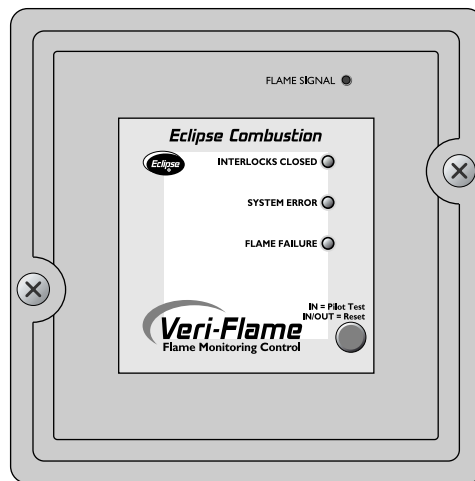

No Purge Model

Table 8.2 LED Status & Conditions for Veri-Flame Purge Models

LED(s) LIT	POSSIBLE CAUSES
INTERLOCKS CLOSED	1) The interlocks are closed (normal operation), power on terminal 7.
SYSTEM ERROR	1) The flame detected is out of sequence, flame signal light is on. 2) The sensor is "runaway", flame signal light is on. 3) Inductance is detected on sensor wires, flame signal light is on. 4) Voltage wired into terminals 3, 4 or 5. 5) Internal relay contacts welded. 6) Internal controller failure. 7) Air flow switch closed before start-up. 8) Main fuel valve switch opens after shutdown or before start-up, no power to V.
FLAME FAILURE	1) Pilot flame is not established in selected TFI. 2) Main flame is not established in selected TFI. 3) Main flame fails within 35 seconds of TFI. 4) Flame failed during operation in non-recycle mode. 5) Flame failed 35 seconds after TFI and was not established after one try in recycle mode.
AIR FAILURE	1) Air flow switch not closed within ten seconds of start-up. 2) Air flow switch is open during timing cycle. 3) Air flow switch is open during firing cycle.

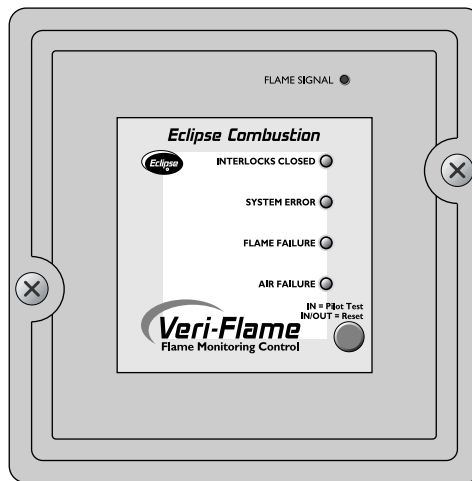

Purge Model

Table 8.3 LED Status & Conditions for Veri-Flame Modulation Models

LED(s) LIT	POSSIBLE CAUSES
INTERLOCKS CLOSED	1) The interlocks are closed (normal operation), power on terminal 7.
SYSTEM ERROR	1) The flame detected is out of sequence, flame signal light is on. 2) The sensor is "runaway", flame signal light is on. 3) Inductance is detected on sensor wires, flame signal light is on. 4) Voltage wired into terminals 3, 4 or 5. 5) Internal relay contacts welded. 6) Internal controller failure. 7) Air flow switch closed before start-up. 8) High purge damper switch and/or main fuel valve switch opens during start-up. 9) Low fire switch not made before TFI.
FLAME FAILURE	1) Pilot flame is not established in selected TFI. 2) Main flame is not established in selected TFI. 3) Main flame fails within 35 seconds of TFI. 4) Flame failed during operation in non-recycle mode. 5) Flame failed 35 seconds after TFI and was not established after try in recycle mode.
AIR FAILURE	1) Air flow switch not closed within ten seconds of start-up. 2) Air flow switch is open during timing cycle. 3) Air flow switch is open during firing cycle.
INTERLOCKS CLOSED and AUTO	1) Burner in run mode, firing rate determined by automatic controller (normal operation).
INTERLOCKS CLOSED and HIGH FIRE	1) Purge high sequence (normal operation).
INTERLOCKS CLOSED and LOW FIRE	1) Purge low sequence (normal operation).

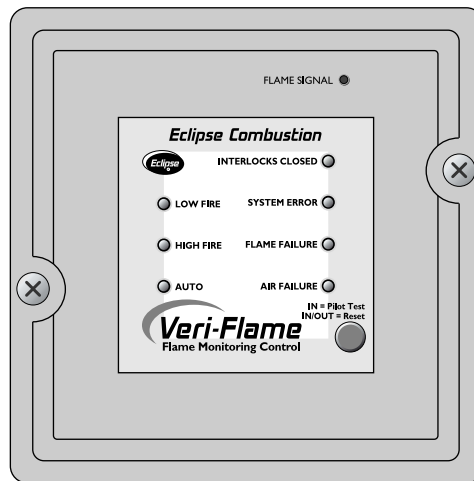

Modulation Model



Remote Display Messages

9

INTRODUCTION

This section covers how the optional remote display is used with the Veri-Flame. The remote display provides LCD messages which monitor the status of the Veri-Flame's functions as well as any lockout conditions. This section is divided into two parts or tables:

- The first table describes the start-up and shutdown monitoring sequences of the Veri-Flame and how the progress (or halt) of the sequence can be monitored by the messages on the remote display.
- The second table alphabetically lists and explains the diagnostic messages which can appear on the remote display.

Table 9.1 Veri-Flame Operating Sequence

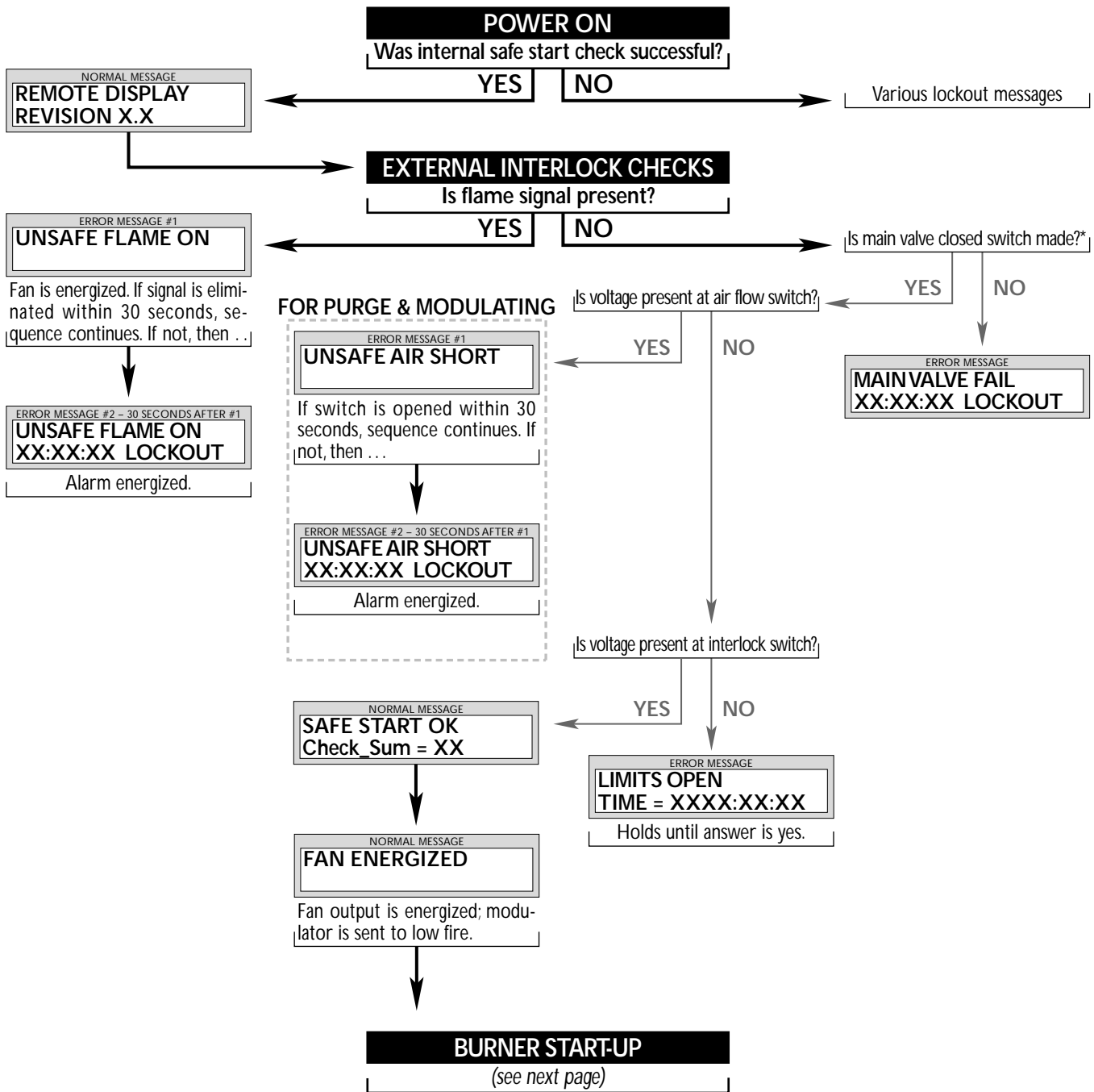

* Applies to purge and no purge models only.

Table 9.1 Veri-Flame Operating Sequence (continued)

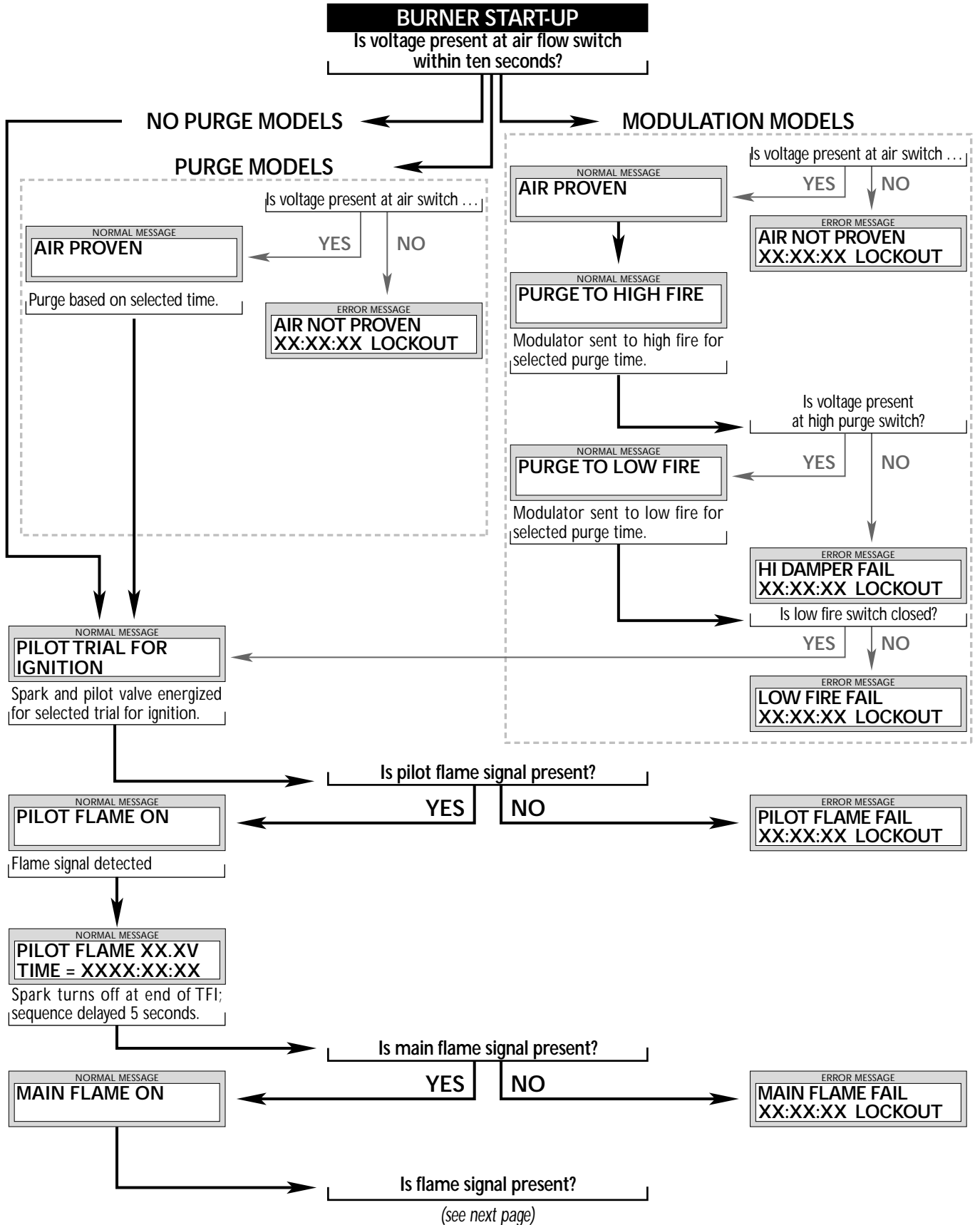

Table 9.1 Veri-Flame Operating Sequence (continued)

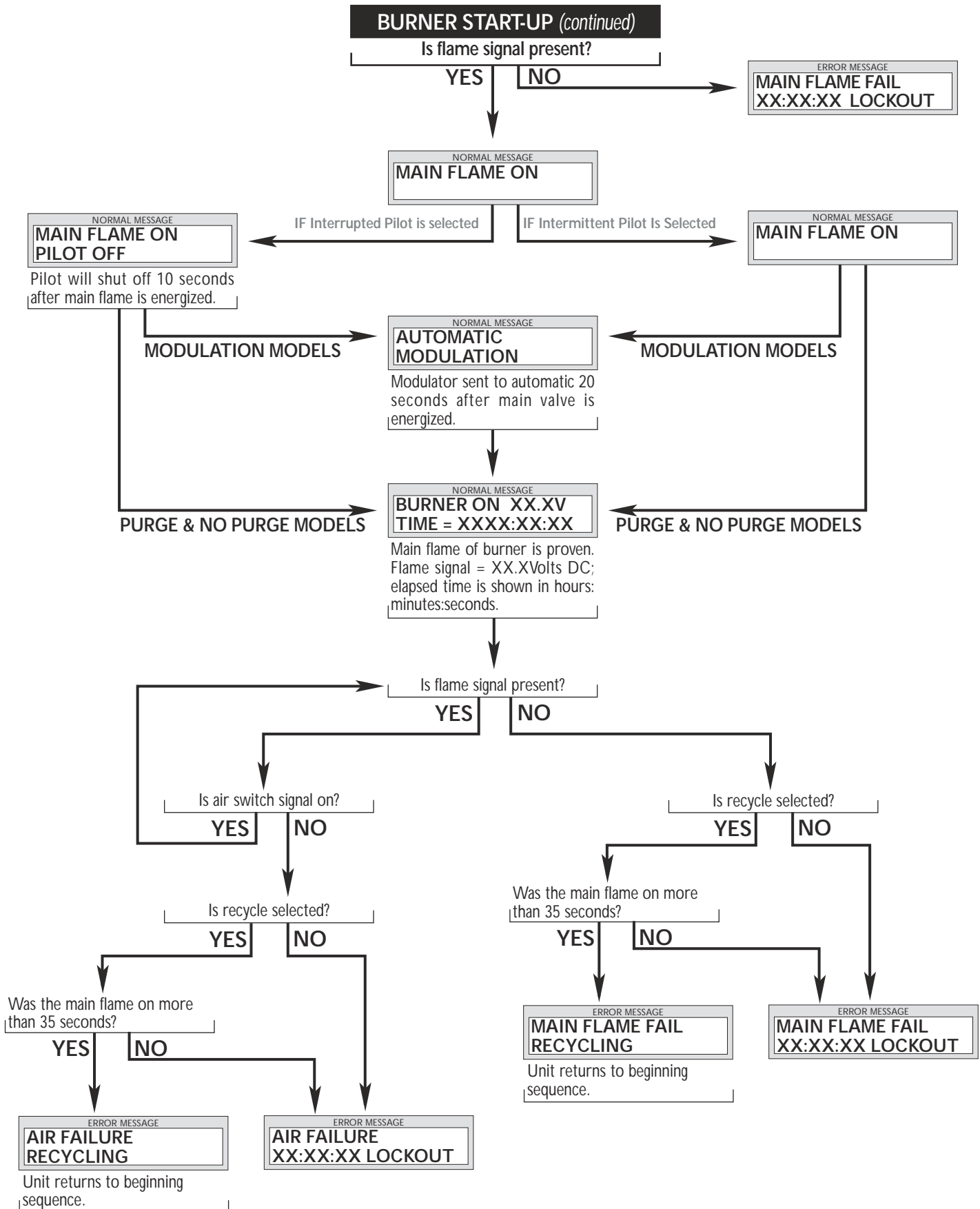
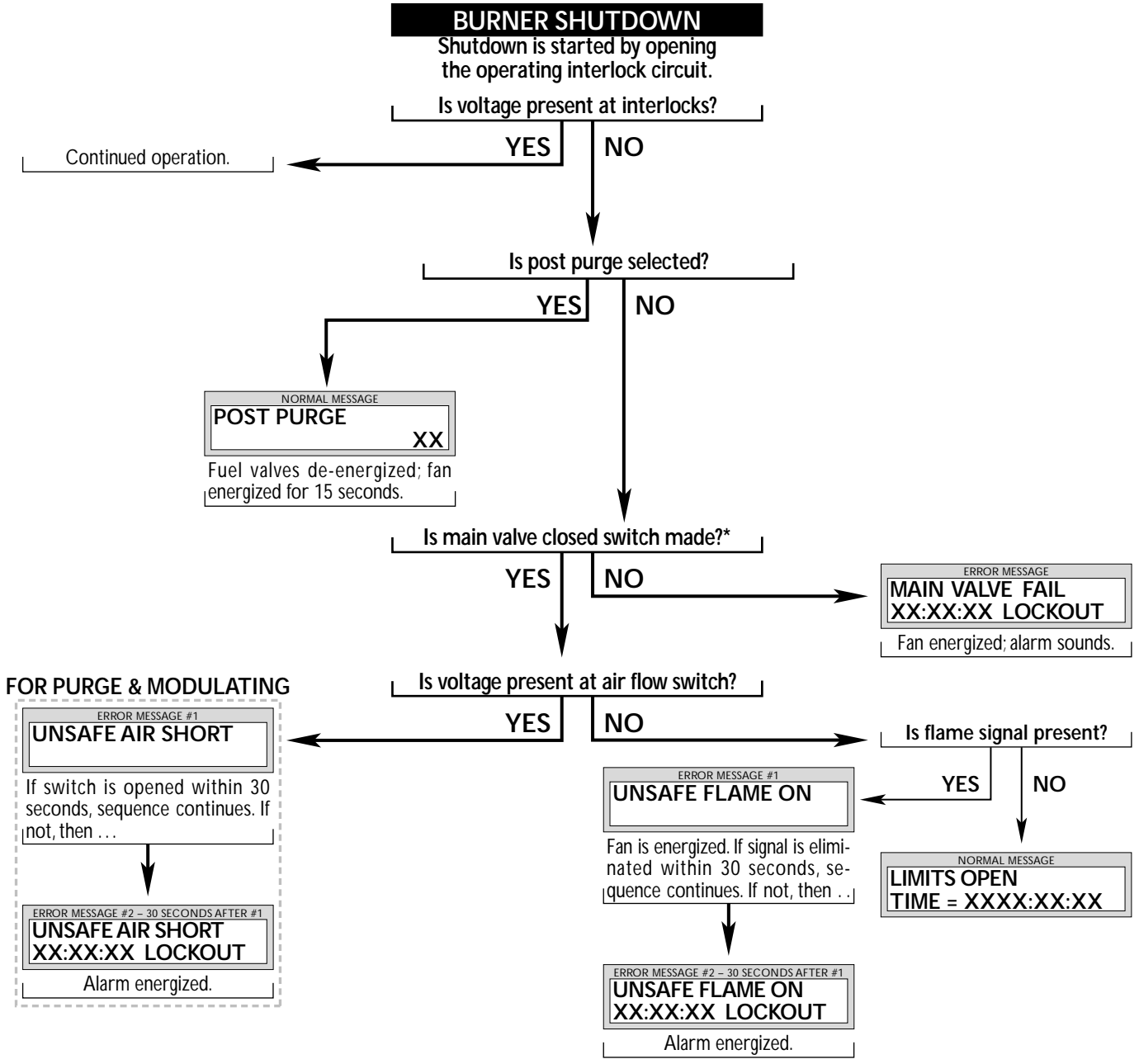

Table 9.1 Veri-Flame Operating Sequence (continued)



* Applies to purge and no purge models only.

Table 9.2 Remote Display Diagnostic Messages (Listed Alphabetically)

MESSAGE	TYPE	EXPLANATION
AIR FAILURE XX:XX:XX LOCKOUT	Lockout	For purge & modulation models: Combustion air flow limit switch opened for more than two seconds once initially proven.
AIR FAILURE RECYCLING	Status	For purge & modulation models: Combustion air flow limit switch opened; if "recycle" has been selected, the Veri-Flame will restart the sequence after air failure (see "Recycle Mode" on page 14).
AIR NOT PROVEN XX:XX:XX LOCKOUT	Lockout	For purge & modulation models: Combustion air flow limit switch did not make within ten seconds of fan being energized.
AIR PROVEN	Status	For purge & modulation models: Combustion air flow limit switch closed within ten seconds of fan being energized.
AUTOMATIC MODULATION	Status	For modulation models only: Modulating motor is sent to automatic operation.
BURNER ON XX.XV TIME=XXXX:XX:XX	Status	Main flame of burner is proven in the automatic modulation mode; flame strength is XX.XV (volts DC). Elapsed time is shown in hours:minutes:seconds.
D-INTERNAL FAIL XX:XX:XX:XX LOCKOUT	Lockout	For modulation models only: Internal control failure; replace controller.
FAN ENERGIZED	Status	For purge & modulation models: Blower motor is energized at the start of pre-purge.
FLAME FAILURE XX:XX:XX LOCKOUT	Lockout	Main flame lost during operation in the automatic modulation mode. Burner number (X) given of failed unit.
HI DAMPER/POVC XX:XX:XX LOCKOUT	Lockout	For modulation models only: High damper or high purge rate switch did not make at the end of pre-purge to high fire.
K-INTERNAL FAIL XX:XX:XX LOCKOUT	Lockout	Internal control failure; replace controller.
L-INTERNAL FAIL XX:XX:XX LOCKOUT	Lockout	Internal control failure; replace controller.
LIMITS OPEN TIME=XXXX:XX:XX	Status	The controller has completed its internal checks and is standing by for the interlocks to close.
LOW FIRE FAIL XX:XX:XX LOCKOUT	Lockout	For modulation models only: Low fire switch is open just prior to pilot trial for ignition.
MAIN FLAME FAIL XX:XX:XX LOCKOUT	Lockout	Main flame was not established during the main burner trial for ignition.
MAIN FLAME FAIL RECYCLING	Status	Main flame lost during automatic modulation; control will recycle once if "recycle" has been selected.

Table 9.2 Remote Display Diagnostic Messages (continued)

MESSAGE	TYPE	EXPLANATION
MAIN FLAME ON	Lockout	Main valve has been energized and main flame proven during trial for ignition.
MAIN FLAME ON PILOT OFF	Status	Pilot valve is de-energized and main flame is on.
MAIN VALVE FAIL XX:XX:XX LOCKOUT	Lockout	For purge and no purge models: Main valve closed switch is open before start-up or after burner shutdown.
NO PURGE SELECT XX:XX:XX LOCKOUT	Lockout	For purge & modulation models: No purge time was selected; lockout prior to purge to high fire.
PILOT FLAME FAIL XX:XX:XX LOCKOUT	Lockout	Pilot flame was not established during the pilot trial for ignition.
PILOT ON	Status	Pilot flame is proven; transformer is de-energized; remaining count-down for pilot trial for ignition is.
PILOT TRIAL FOR IGNITION	Status	Pilot valve and ignition transformer are energized; countdown for pilot trial for ignition begins.
POST PURGE	Status	For purge & modulation models: 15 second post purge is started on burner shutdown.
PROGM SWITCH ERR XX:XX:XX LOCKOUT	Lockout	DIP switch improperly set or changed during cycle.
PURGE TO HIGH FIRE	Status	For modulation models only: Modulating motor is sent to high fire.
PURGE TO LOW FIRE	Status	For modulation models only: Modulating motor is sent to low fire.
RELAY FAIL XX:XX:XX LOCKOUT	Lockout	Internal relay(s) fail initial check. Check ratings. If lockout still occurs after overload is eliminated, replace control.
SAFE START OK	Status	Control has completed internal safe-start check.
UNSAFE AIR SHORT	Status	For purge & modulation models: Combustion air switch is closed before start-up or after shutdown; control holds start-up until switch reopens; if interlocks close before switch opens, alarm is energized.
UNSAFE AIR SHORT XX:XX:XX LOCKOUT	Lockout	For purge & modulation models: Same conditions as above, except the interlocks close before the switch reopens, causing a lockout and the alarm being energized.

Table 9.2 Remote Display Diagnostic Messages (continued)

MESSAGE	TYPE	EXPLANATION
UNSAFE FLAME ON	Hold	Flame signal—actual, induced, or runaway scanner—is detected before start-up or after shutdown. The fan is energized. If the cause is corrected within 30 seconds, as in afterburn, the control will turn off the fan and continue the sequence.
UNSAFE FLAME ON XX:XX:XX LOCKOUT	Lockout	Same conditions as above, except the cause has not been corrected within 30 seconds, resulting in a lockout and the alarm being energized.
UNSAFE-FLM-PURGE	Hold	For purge & modulation models: Flame signal—actual, induced, or runaway scanner—is detected during the selected purge time period. The fan is energized. If the cause is corrected within 30 seconds, as in afterburn, the control will turn off the fan and continue the sequence.
UNSAFE-FLM-PURGE XX:XX:XX LOCKOUT	Lockout	For purge & modulation models: Same conditions as above, except the cause has not been corrected within 30 seconds, resulting in a lockout and the alarm being energized.
V-INTERNAL FAULT XX:XX:XX LOCKOUT	Lockout	Internal control failure; replace controller.
WATCHDOG FAIL XX:XX:XX LOCKOUT	Lockout	Internal control failure; replace controller.
XXXXXXX XXXXXTESTXX	Status	In combination with other messages, shows the control is in the minimum pilot test mode.



Appendix

CONVERSION FACTORS

Metric to English.

FROM	TO	MULTIPLY BY
cubic meter (m ³)	cubic foot (ft ³)	35.31
cubic meter/hour (m ³ /h)	cubic foot/hour (cfh)	35.31
degrees Celsius (°C)	degrees Fahrenheit (°F)	(°C x 1.8) + 32
kilogram (kg)	pound (lb)	2.205
kilowatt (kW)	Btu/hr	3414
meter (m)	foot (ft)	3.28
millibar (mbar)	inches water column ("wc)	0.401
millibar (mbar)	pounds/sq in (psi)	14.5 x 10 ⁻³
millimeter (mm)	inch (in)	3.94 x 10 ⁻²

Metric to Metric.

FROM	TO	MULTIPLY BY
kiloPascals (kPa)	millibar (mbar)	10
meter (m)	millimeter (mm)	1000
millibar (mbar)	kiloPascals (kPa)	0.1
millimeter (mm)	meter (m)	0.001

English to Metric.

FROM	TO	MULTIPLY BY
Btu/hr	kilowatt (kW)	0.293 x 10 ⁻³
cubic foot (ft ³)	cubic meter (m ³)	2.832 x 10 ⁻²
cubic foot/hour (cfh)	cubic meter/hour (m ³ /h)	2.832 x 10 ⁻²
degrees Fahrenheit (°F)	degrees Celsius (°C)	(°F - 32) ÷ 1.8
foot (ft)	meter (m)	0.3048
inches (in)	millimeter (mm)	25.4
inches water column ("wc)	millibar (mbar)	2.49
pound (lb)	kilogram (kg)	0.454
pounds/sq in (psi)	millibar (mbar)	68.95

ILLUSTRATED PARTS LIST

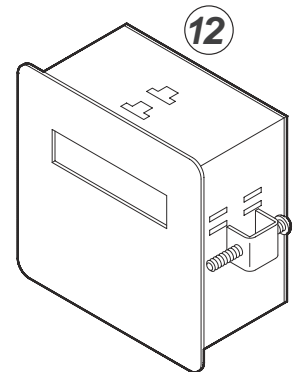
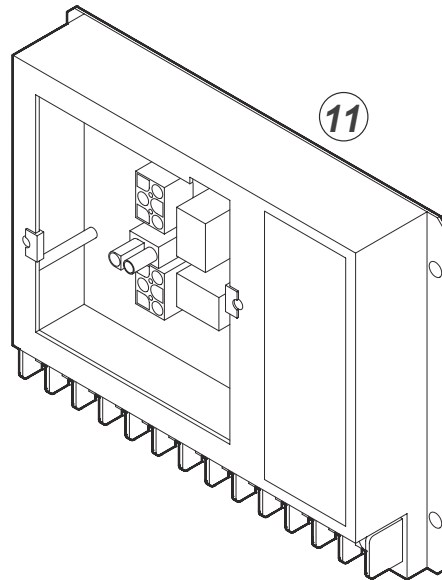
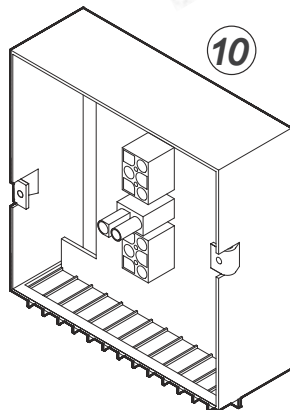
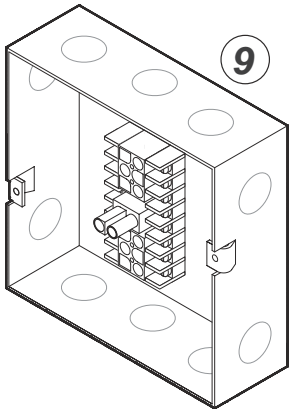
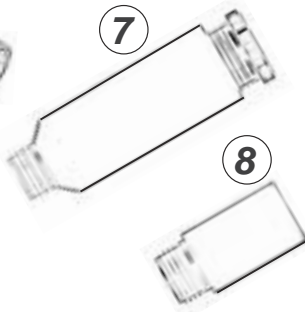
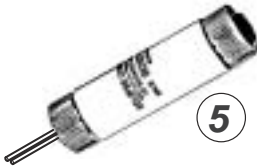
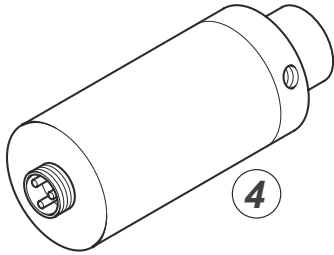
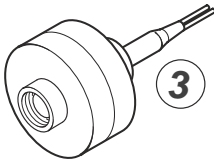
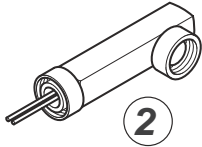
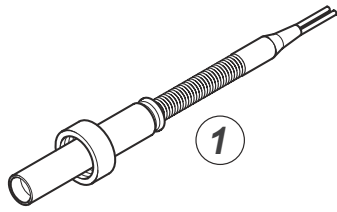

Category	Pos. No.	Description	Model Number	Part Number
Sensors	1	Straight U.V. scanner	5600-91	49600-91
	—	NEMA 4 U.V. scanner	5600-91N4	20898
	2	90° U.V. scanner	5600-90A	49600-90
	3	I.R. scanner	5600-92B	49600-92
	4	Self-check scanner	5602-91	49602-91
	5	Solid-state U.V./I.R. scanner	5600-92SC	21349
	—	10-foot cable for self-check scanner	5602-91-7	49602-91-7
	6	Scanner support (max. temp. 220°F) (1)	5600-90A SS	20722
	6	Scanner support (max. temp. 475°F) (1)	5600-90A SSH	20723
	7	Magnifying lens assembly	5600-98	49600-98
—	Lens, magnifying	—	49600-99	
—	Lens, non-magnifying (2)	—	18165	
8	Insulated coupling	5600-99	49099	
—	Cable, coax, RG62A/U for flame rod	—	21741	
Bases	9	Internal terminal base, metal	5602-10	49602-10
	10	Exposed terminal base, metal	5602-10-1	49602-10-1
	—	Internal terminal base, plastic	5602-10-P	22194
	—	Adapter Base RA890	5602-12	49602-12
	—	Adapter Base R4795	5602-14	49602-14
	11	Modulation base	5602-40	49602-40
—	Screw, mounting to plastic base	—	22110	
—	Screw, mounting to metal base	—	22385	
Test	—	Tester for Veri-Flame units	5602	49602
	—	Relay module (3)	5602-40-4	49240-2
Display	12	Remote display, 24V	5602 DB	20316
	—	Remote display, 120VAC with keypad	5602 DBP	20896
	—	Power supply, 24VDC (4)	—	20317
	—	Cable for remote display	—	20318

(1) For 90° U.V. scanner (Model No. 5600-90A), I.R. scanner (5600-92B), and solid state U.V./I.R. scanner (5600-92SC)

(2) For magnifying lens assembly (Model No. 5600-98), and self-check scanner (5602-91)

(3) Used to test modulation controls on tester (Model No. 5602) above.

(4) To be used with 20316 display only (not 20896).

ECLIPSE™
Innovative Thermal Solutions

Eclipse Combustion

www.eclipsenet.com

Free Manuals Download Website

<http://myh66.com>

<http://usermanuals.us>

<http://www.somanuals.com>

<http://www.4manuals.cc>

<http://www.manual-lib.com>

<http://www.404manual.com>

<http://www.luxmanual.com>

<http://aubethermostatmanual.com>

Golf course search by state

<http://golfingnear.com>

Email search by domain

<http://emailbydomain.com>

Auto manuals search

<http://auto.somanuals.com>

TV manuals search

<http://tv.somanuals.com>