



- **PLEASE** study these instructions carefully before installing your new camshaft. If you have any questions or problems, do not hesitate to call our **Technical Hotline at: 1-800-416-8628**.
- **CAMSHAFT:** Edelbrock Performer RPM camshafts are ground specifically for use with the corresponding Performer RPM manifold. The Performer RPM manifold #7176, and Performer RPM camshaft #7177, are designed to work as a team to give you better driveability and performance. They are dyno-matched and street-proven. For best results, use the Edelbrock manifold/camshaft package with the carburetor and headers we recommend. The Performer RPM camshafts are designed for use with modified or high performance cylinder heads or #6077 Performer RPM cylinder heads and valve train components only. H.P. adjustable rocker arms or adjustable pushrods must be used. The parts described here will physically fit 318 c.i.d. engines, but users should be advised that these parts were developed for optimum performance in engines of 340-360 cubic inches. When using a 318 c.i.d. engine, we strongly recommend the use of late model 360 cylinder heads. This is due to the extremely small intake and exhaust ports which can severely limit performance when 318 cylinder heads are used.
NOTE: Maximum performance is achieved only when the Edelbrock Performer RPM Total Power Package components are used with the following equipment:
 - Performer RPM manifold/camshaft/timing set/valve springs
 - Performer RPM cylinder heads, #6077
 - Performer Series carburetor #1407 (750 cfm)
 - fuel delivery system of sufficient capacity
 - 1-3/4" headers
 - aftermarket/re-curved distributors
- **IMPORTANT:** This instruction sheet provides general installation guidelines which can affect your warranty. Read it carefully. It is not our intent to cover each detail of installation here; a step-by-step procedure manual would be far too lengthy. We want to caution you that installing a camshaft is a complicated procedure that requires a good general knowledge of automotive engines. If you are not confident that you can complete the camshaft installation successfully, we suggest you consider having it installed by an experienced mechanic.

CAUTION: Improper installation will result in **LOW MILEAGE, POOR PERFORMANCE, COSTLY REINSTALLATION, and ENGINE DAMAGE.**

TO AVOID THESE PROBLEMS YOU MUST DO THE FOLLOWING:

Carefully study and understand all instructions.

Examine the camshaft for possible shipping damage (if damaged contact your dealer immediately).

PREPARATION CHECKLIST

• **TOOLS AND EQUIPMENT**

Use the following checklist for items needed.

box and open-end wrenches
socket set
distributor wrench
pliers (channel locks & hose clamp)
screw drivers (regular and phillips)
torque wrench
hammer
gasket scraper or putty knife
timing light
vacuum gauge
rags
water bucket
harmonic balancer puller

• **HARDWARE & PARTS TO BUY**

gaskets- Edelbrock, OEM or equivalent
pipe plugs, if needed
Edelbrock Gasgacinch, #9300
RTV Silicone
chalk
paper and pencil
radiator coolant
teflon tape
Edelbrock Performer-Link True Rolling Timing Chain and Gear Set #7803
Edelbrock Sure Seat Valve Springs, #5777
Intake gaskets- Fel-Pro Printoseal or equivalent
Manifold bolt kit #8579

INSTRUCTIONS FOR ENGINE PARTS REMOVAL

• BEFORE CAMSHAFT INSTALLATION

1. Disconnect battery.
2. For ease of installation, keep all parts in some sort of order.
WARNING: Do not remove radiator cap or radiator hose if engine is hot.
3. Drain radiator coolant, move fan shroud back and remove fan and spacer from water pump. On air conditioned vehicles, remove bolt, lower idler pulley and compressor-to-water pump mount. Disconnect hoses and brackets. Most vehicles will require radiator removal prior to cam removal. Remove water pump.
4. Disconnect all linkage from carburetor such as throttle, throttle springs, transmission, cruise control and automatic choke
5. Tag and remove vacuum lines.
6. Remove valve covers.
7. Remove distributor cap and wires, rotate engine until rotor points towards number 1 terminal in cap and pointer on front cover is on Top Dead Center (TDC) and remove distributor. Note the approximate position of the vacuum advance canister in relation to the manifold to assist in getting the distributor properly located during re-installation.
8. Remove carburetor and intake manifold. Remove fuel pump.
9. Remove rocker arms and pushrods.
10. Remove hydraulic valve lifters.
11. Remove crankshaft pulley and, using a suitable puller, crankshaft dampener.
12. Loosen oil pan and remove front cover.
NOTE: The front cover oil seal should be replaced before the front cover is re-installed.
13. Rotate engine until timing marks are aligned as shown in Figure 2.
14. Remove cam sprocket bolt, washer, and fuel pump eccentric. Slide sprocket and timing chain forward to remove.
15. Remove camshaft thrust plate noting location of oil tab. Install a long bolt in front of camshaft to facilitate removal and carefully remove camshaft. Using appropriate gear puller, remove crank sprocket.

• VALVE SPRINGS

CAUTION: WARNINGS ABOUT YOUR WARRANTY

In order for this Performer RPM cam and lifter kit to be covered under ANY WARRANTY you MUST use the correct Edelbrock Sure Seat Valve Springs. Failure to install new Edelbrock valve springs with your new Performer RPM cam could cause the cam lobes to wear excessively and could cause additional engine damage.

1. This camshaft is designed to function with Edelbrock Sure Seat valve springs #5777. Do not use dual valve springs with this camshaft. Special H.P. retainers may be necessary with your installation for proper spring height. **Do not use rotator type valve springs or retainers for this application.**

• LIFTERS

1. New lifters must be used with new camshaft. Use only the high rev lifters supplied with this kit.
2. Check to be sure that all lifters fit freely in the lifter bores and that the factory did not install oversized lifters in your block to compensate for machining errors.

• INSTALLATION INSTRUCTIONS

1. Coat cam lobes and bottoms of each lifter with MoS2 lube (supplied) to prevent cam lobe and lifter wear from occurring during initial start-up.
2. Install new camshaft with new sprockets, timing chain and lifters.

CAUTION: Use Edelbrock Performer-Plus True Rolling Timing Chain and Steel Gear Set #7803. Do not use late model timing chain & gear sets that are designed in a retarded position and are not recommended for this camshaft installation. Edelbrock Timing Sets feature three keyways for specific timing selection. Use locking compound material on the bolt threads holding timing gear to cam. Torque to factory recommendations specified in motor repair manual.

Install camshaft with timing marks lined up as recommended by factory specifications. See Figure 2.

When using Performer-Plus Timing Chain and Gear Sets (7800 series) with Edelbrock cam and lifter kits, straight up timing alignment is achieved. If any other timing gear set is used, it is necessary to check cam position for correct timing alignment. This requires indexing the camshaft with a degree wheel to verify timing alignment. O.E.M. or non-Edelbrock timing gear sets are not recommended for use with Edelbrock camshafts.

• INSTALLING PUSHRODS AND ROCKER ARMS

High performance pushrods and rocker arms are recommended for this installation.

After the cam is installed and timed correctly (see Figure 2), it will be necessary to check each pushrod for correct lifter preload.

• VALVE ADJUSTMENT

1. Turn the engine over until the No. 1 cylinder exhaust lifter starts to move up. Adjust intake rocker arm to zero clearance between rocker arm and valve tip. From this point turn adjusting nut down (clockwise) 1/4 turn more for final adjustment.
2. Turn the engine over again until the intake lifter just stops coming down. Adjust exhaust rocker arm to zero clearance between rocker arm and valve tip. From this point turn adjusting nut down (clockwise) 1/4 turn more for final adjustment.
3. The above procedure assures correct hydraulic lifter preload. Repeat this procedure for each of the other seven cylinders.
4. Re-install front cover, fuel pump, water pump, and oil pan using new gaskets.
5. Install intake manifold using new intake gasket set and torque manifold bolts to 25 ft./lbs. **CAUTION:** Remove front and rear seal dowel pins in block if so equipped.
6. Install crankshaft dampener and torque to factory specifications.

• INSTALLING DISTRIBUTOR AND TIMING ENGINE

NOTE: Before installing your distributor, check the gear drive on the distributor and oil pump for any signs of wear. If worn, be sure to replace with new or you may wear out your camshaft prematurely. This is especially true when rebuilding your engine and a high performance oil system is used, which generates a heavier load on the camshaft gear system. Edelbrock camshafts are designed to use OEM-type gears only.

1. Turn the engine over in the direction of rotation until the No. 1 intake valve closes and continue until the pointer on the front cover is approximately 5 degrees BTDC.
2. Re-install the distributor with the rotor pointing towards No. 1

terminal in the cap, and with the vacuum advance canister in its original position.

3. Lightly tighten the hold-down clamp so that the distributor can still be turned to determine final setting using a timing light with the engine running.
4. Replace valve covers, carburetor linkage and remaining vacuum and electrical connections.
5. Re-install air conditioner, if so equipped.
6. Refill radiator with coolant and re-connect battery.
7. Double check all connections, fuel lines, etc. before starting engine.

- **CAMSHAFT/LIFTER RUN-IN**

CAUTION: Change the engine oil and filter before start-up and again after the initial break-in. Do not allow the engine to run 2000 for the first 1/2 hour. Vary engine speed between 2000 rpm and 2500 rpm. Slow idle speeds may result in severe cam and lifter wear.

1. Start the engine and bring to break-in rpm.

IMPORTANT INSTRUCTIONS AFFECTING YOUR WARRANTY

- **CAM LOBE WEAR-** Cam lobe wear is almost non-existent unless mismatched parts are used or installation of the cam and lifters is done improperly. Most cam damage is caused by the timing gear coming loose due to improper torque on bolt. The bolt holding gear to camshaft should be torqued carefully and a locking compound applied to threads of bolt.

- **CAM GEARS AND CAMSHAFT END PLAY-** If cam gear becomes loose, the cam will slide back in the block, causing the lifters to hit the lobes next to them and also the cam bearing journals. If the engine is run after this happens, the bottom of the lifters and the sides of the lobes will become clipped.

When installing a camshaft, it is always important to check for proper operating clearances, especially when high performance components are used. Things to look for that can cause failure and damaged parts are as follows:

1. Improper valve-to-piston clearance (this should be no less than 0.080").
2. Rocker arm to retainer clearance (both ends; valve closed and open).
3. Proper spring settings (see dimensions with spring instruction sheet; correct dimensions mean maximum performance and longer engine life).

- **SPECIAL INSTRUCTIONS**

With the Edelbrock manifold and camshaft package plus a header installation, a carburetor jet change may be required for best performance. Due to the varied applications of year and model of vehicles, no one combination could suffice for all installations. The following procedure is only a guideline and in many cases, the manufacturing specifications for recommended carburetors or timing may be best.

- **IGNITION TIMING**

Ignition timing for this package may vary with each application. A good starting figure would be between 10 degrees to 14 degrees initial timing at idle with vacuum advance disconnected. Total advance should not exceed 32 degrees to 36 degrees with initial and centrifugal weights combined and should be at full advance at 3000 RPM. After timing is adjusted, re-connect the vacuum advance line. **NOTE:** The best combination for any particular vehicle or application must be determined by trial and error using the above information as a guideline.

- **HEADERS**

For best performance, headers are recommended. For this application, they should be 1-3/4" diameter, approximately 31" long and terminating into a 3" collector. The remainder of the exhaust system should consist of dual exhaust and tail pipes, at least 2" diameter with low back-pressure mufflers.

- **WARNING**

In order for this Performer RPM cam and lifter kit to be covered under ANY WARRANTY you MUST use the correct Edelbrock Sure Seat Valve Springs. The end flap or label from your Sure Seat Valve Spring box must be sent in with your camshaft warranty card.

Failure to install new Edelbrock Sure Seat Valve Springs with your new Performer RPM cam and lifter kit could cause the cam lobes to wear excessively and could cause additional engine damage. **IF YOU HAVE ANY QUESTIONS ABOUT THIS APPLICATION, PLEASE CONTACT OUR TECHNICAL DEPARTMENT IMMEDIATELY.**

- **PLEASE** complete and mail your warranty card. Be sure to write the model number of this product in the "Part #____" space.

THANK YOU.

- **CAUTION:** Use Edelbrock Performer-Plus Timing Chain and Gear Set #7803. Do not use late model timing chain and gear sets that are designed for emission-controlled engines. These timing sets are machined in a retarded position and are not recommended for this camshaft installation. Edelbrock Timing Sets feature three keyways for specific timing selection.

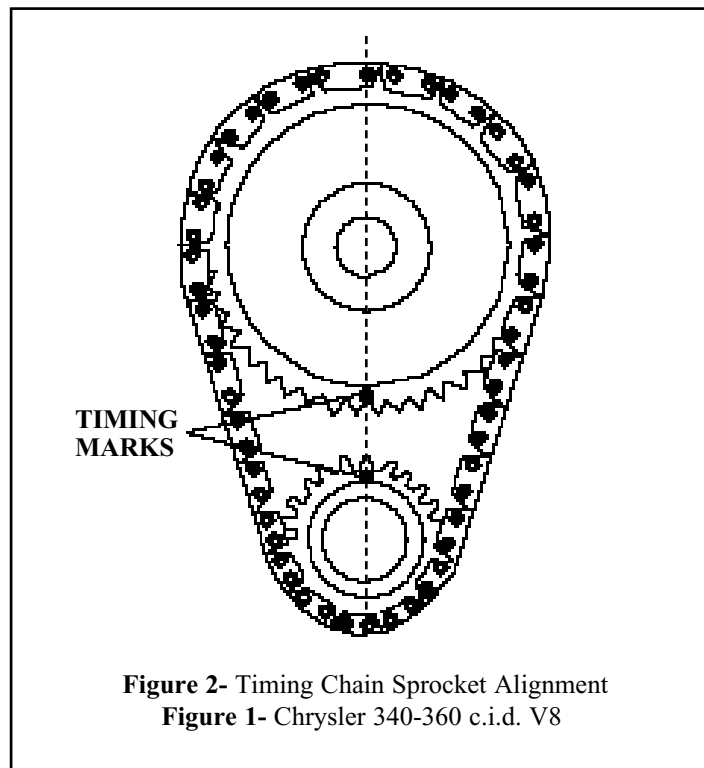
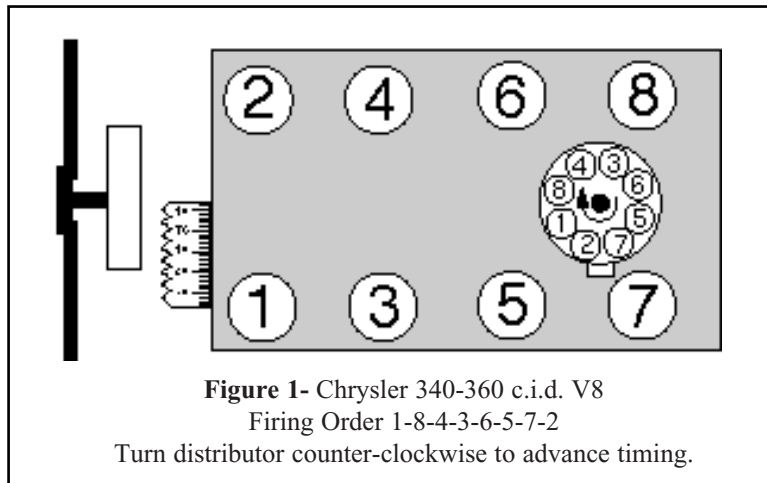

**CAMSHAFT: Performer RPM Hydraulic
CATALOG #7177**

ENGINE: Chrysler 340-360 c.i.d. V8

RPM RANGE: 1500-6500

CAUTION: Do not use dual valve springs.

Use only recommended Edelbrock Sure Seat Valve Springs #5777.

Use stock ratio rocker arms only.

Duration at .006" Lift: Intake 308° Exhaust 318°

Duration at .050" Lift: Intake 234° Exhaust 244°

Lift at cam: Intake .325" Exhaust .340"

Lift at valve: Intake .488" Exhaust .510"

Timing at .050 Lift:

	Open	Close
Intake	10° BTDC	44° ABDC
Exhaust	59° BBDC	5° ATDC

Intake Centerline: 107°

Lobe Separation: 112°

• **CAUTION:** Use Edelbrock Performer-Plus Timing Chain and Steel Gear Set #7803. Do not use late model timing chain and gear sets that are designed for emission-controlled engines. These timing sets are machined in a retarded position and are not recommended for this camshaft installation. Edelbrock Timing Sets feature three keyways for specified timing selection.

**CAMSHAFT: Performer RPM Hydraulic
CATALOG #7177**

ENGINE: Chrysler 340-360 c.i.d. V8

RPM RANGE: 1500-6500

CAUTION: Do not use dual valve springs.

Use only recommended Edelbrock Sure Seat Valve Springs #5777.

Use stock ratio rocker arms only.

Duration at .006" Lift: Intake 308° Exhaust 318°

Duration at .050" Lift: Intake 234° Exhaust 244°

Lift at cam: Intake .325" Exhaust .340"

Lift at valve: Intake .488" Exhaust .510"

Timing at .050 Lift:

	Open	Close
Intake	10° BTDC	44° ABDC
Exhaust	59° BBDC	5° ATDC

Intake Centerline: 107°

Lobe Separation: 112°

• **CAUTION:** Use Edelbrock Performer-Plus Timing Chain and Steel Gear Set #7803. Do not use late model timing chain and gear sets that are designed for emission-controlled engines. These timing sets are machined in a retarded position and are not recommended for this camshaft installation. Edelbrock Timing Sets feature three keyways for specified timing selection.

**CAMSHAFT: Performer RPM Hydraulic
CATALOG #7177**

ENGINE: Chrysler 340-360 c.i.d. V8

RPM RANGE: 1500-6500

CAUTION: Do not use dual valve springs.

Use only recommended Edelbrock Sure Seat Valve Springs #5777.

Use stock ratio rocker arms only.

Duration at .006" Lift: Intake 308° Exhaust 318°

Duration at .050" Lift: Intake 234° Exhaust 244°

Lift at cam: Intake .325" Exhaust .340"

Lift at valve: Intake .488" Exhaust .510"

Timing at .050 Lift:

	Open	Close
Intake	10° BTDC	44° ABDC
Exhaust	59° BBDC	5° ATDC

Intake Centerline: 107°

Lobe Separation: 112°

• **CAUTION:** Use Edelbrock Performer-Plus Timing Chain and Steel Gear Set #7803. Do not use late model timing chain and gear sets that are designed for emission-controlled engines. These timing sets are machined in a retarded position and are not recommended for this camshaft installation. Edelbrock Timing Sets feature three keyways for specified timing selection.

**CAMSHAFT: Performer RPM Hydraulic
CATALOG #7177**

ENGINE: Chrysler 340-360 c.i.d. V8

RPM RANGE: 1500-6500

CAUTION: Do not use dual valve springs.

Use only recommended Edelbrock Sure Seat Valve Springs #5777.

Use stock ratio rocker arms only.

Duration at .006" Lift: Intake 308° Exhaust 318°

Duration at .050" Lift: Intake 234° Exhaust 244°

Lift at cam: Intake .325" Exhaust .340"

Lift at valve: Intake .488" Exhaust .510"

Timing at .050 Lift:

	Open	Close
Intake	10° BTDC	44° ABDC
Exhaust	59° BBDC	5° ATDC

Intake Centerline: 107°

Lobe Separation: 112°

• **CAUTION:** Use Edelbrock Performer-Plus Timing Chain and Steel Gear Set #7803. Do not use late model timing chain and gear sets that are designed for emission-controlled engines. These timing sets are machined in a retarded position and are not recommended for this camshaft installation. Edelbrock Timing Sets feature three keyways for specified timing selection.

Free Manuals Download Website

<http://myh66.com>

<http://usermanuals.us>

<http://www.somanuals.com>

<http://www.4manuals.cc>

<http://www.manual-lib.com>

<http://www.404manual.com>

<http://www.luxmanual.com>

<http://aubethermostatmanual.com>

Golf course search by state

<http://golfingnear.com>

Email search by domain

<http://emailbydomain.com>

Auto manuals search

<http://auto.somanuals.com>

TV manuals search

<http://tv.somanuals.com>