



Astro LS Passenger Van



Astro LT All-Wheel-Drive Passenger Van

## WHAT ASTRO IS

With Ford Aerostar scheduled to cease production in August, Astro stands alone as the only midsize van,\* with more cargo capacity, payload capacity and a higher trailer towing rating than any typical front-wheel-drive minivan can provide.

The rear-wheel-drive Astro is a favorite with van buyers who need more room and capability than typical front-wheel-drive vans offer, but don't want the bulk of a full-size van.

Astro is available in either rear- or All-Wheel Drive, as a passenger van or a cargo van with three trim levels available for the passenger van. Astro also demonstrates its versatility through its impressive cargo hauling and towing capabilities. On the inside, Astro offers as much as 170.4 cubic feet of cargo room — enough room to haul a 4' x 8' sheet of plywood with the rear doors closed.

And, towing is no problem. When properly

equipped, Astro can tow as much as 5,500 pounds. This is due, in part, to its rear-wheel-drive platform, now unique in the midsize van segment.\*

Astro takes safety seriously, with a long list of standard safety features, such as driver and front-passenger air bags, Daytime Running Lamps (DRL) and a 4-wheel anti-lock brake system (ABS).

Under the hood is a powerful standard Vortec 4300 V6 SFI engine that produces 190 horsepower and 250 lb.-ft. of torque, giving Astro the power to perform a variety of tasks. And, with extended service intervals, Astro helps make life a little easier.

In keeping with its rugged, hardworking and versatile reputation, Astro is part of the Chevy Truck sponsorship of the U.S. Ski Team and the Sarah Will Woman's Sport Foundation, a group dedicated to providing athletic challenges to people with physical handicaps.

\*Excludes other GM vehicles.

## Astro Models

- Passenger Van, rear-wheel drive
- Passenger Van, All-Wheel Drive
- Cargo Van, rear-wheel drive
- Cargo Van, All-Wheel Drive.

Three trim levels are available for Astro Passenger Van:

- Astro (with standard trim)
- LS
- LT.

Astro Cargo Van is available only in the standard trim level.



## What's New For 1998:

- Enhanced 4-speed electronically-controlled automatic transmission with Overdrive (see page 9)
- Passlock® theft-deterrent system (see page 4)
- An improved clearcoat paint (interim availability) that helps reduce damage caused by water-spotting, acid rain and environmental etch (see page 7)
- Three new exterior colors: Medium Cadet Blue Metallic, Dark Copper Metallic and Dark Forest Green Metallic
- Two new exterior cladding colors: Dark Forest Green Metallic and Dark Copper Metallic (see page 7)
- Medium Gray replaces Gray as an interior color. (see page 6)



## Alas Poor Aerostar, We Knew Ye Well

With Ford Aerostar scheduled to cease production in August, Chevy Astro stands alone as the only true midsize van in the marketplace.\*

The remaining Astro competitors are really mini-vans, not midsize vans, and can't hold a candle to the overall capability and versatility of Astro.\*

A key to the new dominance of Astro in this market is that Aerostar was the only other midsize van with rear-wheel drive. Now alone with this distinction, Astro holds a tremendous advantage over the remaining front-wheel-drive competitors in terms of cargo hauling and towing capacity.

Here's one example of how the truck-rugged Astro platform pays off for owners: Thanks to its rear-wheel-drive configuration, Astro can tow as much as 2,000 lbs. more than Dodge Caravan or Plymouth Voyager.

With Aerostar gone, there are no midsize competitors for Astro — only minivan competitors — which include:

- Ford Windstar
- Mercury Villager
- VW EuroVan
- Mazda MPV
- Dodge Caravan
- Plymouth Voyager
- Nissan Quest
- Toyota Sienna.

\*Excludes other GM vehicles.

## MODELS AND TRIM LEVELS

### Astro Passenger Van (With Standard Trim)

Even with standard trim, Astro offers a long list of features that make it a good value, including:

- Air conditioning
- Passlock® theft-deterrent system
- 4-wheel anti-lock brake system (ABS)
- Driver and front-passenger air bags
- Delayed-entry interior lights
- Daytime Running Lamps (DRL)
- Intermittent variable wipers
- Scotchgard™ Protector (on floor carpeting and all available cloth seats and trim)
- Under-seat heat ducts
- Passenger-assist handles
- Cup holders
- Three auxiliary power outlets.

### Astro LS Passenger Van

Astro LS offers the same standard features as Astro with standard trim, plus the following:

- 8-passenger seating in Custom Cloth
- Cargo convenience net
- Solar-Ray deep-tinted glass
- Dual adjustable reading lights
- Power door locks and windows
- Body-side moldings
- Tilt-Wheel™ Adjustable Steering Column and electronic speed control with Resume Speed
- Overhead console
- Sunshades with illuminated vanity mirrors
- Power mirrors.

### Astro LT Passenger Van

The LT trim level adds the following equipment, in addition to or replacing LS features:\*

- 8-passenger seating trimmed in Special Cloth
- 6-way power driver seat
- Remote Keyless Entry
- Leather-wrapped steering wheel
- Painted luggage carrier.

### Astro Conversion Van

Chevrolet offers a comprehensive Upfitter Package (RPO YF7) for Astro that provides authorized van converters with a well-equipped basic vehicle, ready to receive the custom features and touches that enhance the enjoyment of Astro as an ideal vehicle for recreation and travel.

### Astro Cargo Van

Astro Cargo Van combines the inherent toughness of a Chevy truck and the nimble handling and efficiency of a minivan with the spacious midsize van roominess only Astro can offer. All this helps make Astro Cargo Van an attractive replacement for the short-wheelbase full-size vans that are no longer offered. Standard features include:

- Air conditioning
- Passlock theft-deterrent system
- 4-wheel anti-lock brake system (ABS)
- Driver and front-passenger air bags
- Daytime Running Lamps (DRL)
- Cup holders.

\*Some features may differ according to model.

## THE CHEVY FAMILY OF VANS

Chevrolet offers six distinctly styled vans, the broadest combination of any manufacturer in the industry. These vans



provide customers broad options in size, power, economy and utility. Chevy Express, Chevy Van, Astro Passenger and Cargo Van, Chevy Venture and the new-for-'98 Venture Cargo Minivan can be equipped to meet the needs of virtually any van customer, whether for personal or commercial use.

**Chevy Express** — With seating for as many as 15 people, Chevy Express is the ideal people mover and cargo hauler. It serves both commercial and personal applications that require “anything goes” versatility in a full-size van.

**Chevy Van** — Offering full-size van flexibility and rugged truck durability, Chevy Van provides exceptional comfort, impressive safety features, superior towing capabilities and is ideal for conversion upfitting or serious cargo-carrying applications thanks to as much as 316.8 cubic feet of cargo room.

**Astro Van** — Chevy Astro Van (passenger and cargo models) is a versatile workhorse, offering a combination of people-moving (as many as 8 passengers), cargo-carrying (as much as 170.4 cu. ft.) and trailering capabilities (as much as 5,500 lbs., when properly equipped).

**Venture** — Chevy Venture completes the Chevrolet family of vans, offering time-challenged customers optimum flexibility, comfort and convenience, while providing “space on demand,” impressive ride and handling and the most standard power of any minivan in its class.

## SAFETY

With a long history of setting automotive safety milestones, GM is a world leader in automotive safety research, development and

testing. The 1998 Astro exemplifies that dedication, providing an outstanding list of safety features. And, with a comprehensive system, emphasizing crash avoidance and occupant protection, Astro owners not only get a versatile van, but additional peace of mind, as well.

### Crash Avoidance Features

- **Standard Daytime Running Lamps (DRL)** turn on automatically when the ignition is on to increase Astro visibility to other drivers. With DRL, the lamps run at a lower intensity than regular headlamps to reduce glare to oncoming drivers. The DRL system is overridden when the vehicle's headlamps are engaged.
- **4-wheel anti-lock brake system (ABS)**, standard on Astro, automatically adjusts brake pressure to the front and rear wheels during hard-braking situations, minimizing wheel lockup and helping maintain steering control. All the driver has to do is keep the brake pedal down.
- **Brake/transmission shift interlock**, a feature of the automatic transmission, requires drivers to depress the brake pedal to shift out of Park.
- **Rear-seat safety belt child comfort guides**, standard on every Astro model, adjust the angle of safety belt crossover, making safety belts more comfortable for children and smaller sized adults riding in the intermediate or rear seats.
- **Sloping hood design** and large windshield contribute to road visibility.

### Safety ... It's in the Bag

There's been a lot of discussion regarding air bag safety. To help Astro owners with air bag safety, Chevrolet developed these guidelines:

- Infants in rear-facing child safety seats should never ride in the front seat of a vehicle with an activated passenger air bag
- Small children should ride in a child safety seat located and properly secured in the center of the vehicle's rear seat. The child safety seat should meet federal requirements for the child's age and size. (Astro offers optional built-in dual child safety seats (middle row) which eliminate the need to carry individual child safety seats.)
- Children ages 12 and younger should ride buckled up in a rear seat
- Everyone should buckle both lap and shoulder safety belts on every trip
- Driver and front-passenger seats should be moved as far back as practical
- Never place an object in the air bag deployment zone.



The Chevy family of vans includes Chevy Express (left), Chevy Van, Astro Van and Venture



## Passlock® ... The Key to Greater Security

Wouldn't it be nice if a vehicle had its own guardian angel to keep it secure when the owner is not around? Well, Astro owners get the next best thing — the security of a standard Passlock® theft-deterrent system.

With Passlock®, if an unauthorized attempt is made to start the vehicle, the ignition system is disabled for ten minutes.

So, while Passlock® doesn't have wings like most guardian angels, we're pretty confident that it can fly in the face of crime.

## SAFETY (contd.)

### Occupant Protection Features

- Standard **driver and front-passenger air bags** are designed to supplement safety belts, helping to restrain front-seat occupants in the event of a moderate to severe frontal impact.
- A standard **three-point energy-absorbing safety belt system** helps restrain outboard passengers by distributing forces to help reduce chest injury.
- Astro base and LS offer optional **built-in child safety seats** for the middle-row seating positions that enhance child safety as well as seating convenience.
- A standard **sliding-door child security lock**, positioned on the front of the sliding door, prevents the door from being opened from the inside when the lock is engaged.
- **Reinforced safety-cage construction** surrounds occupants with a cocoon-like system of structural components. This structure consists of reinforced roof rails and door pillars and beams, which are designed to minimize intrusion into the passenger compartment.
- **Front and rear crush zones** are designed to deform in a controlled manner in the event of a collision to absorb impact energy in order to reduce intrusion into the passenger compartment.
- **Energy-absorbing steering column** and instrument panel are designed to help absorb collision impact, reducing injury to the driver's body.
- **Laminated windshield safety glass** and tempered side and rear safety glass help reduce occupant injuries and ejection during a crash.

### ASTRO INTERIOR FEATURES

With an interior designed with versatility, comfort and convenience in mind, Astro has an impressive roll call of features. Offering five-, seven- or eight-passenger seating, depending on the model and seating arrangement selected, Astro also features as

much as 170.4 cubic feet of cargo room with the rear seats removed — more than any of the front-wheel-drive vans offer. Sporting an ergonomic instrument panel, Astro places complete control at your fingertips. Standard instrumentation includes speedometer, coolant temperature, fuel level, oil pressure, odometer, trip odometer and voltage level.

### Other Features Include:



- Astro now features standard Passlock® theft-deterrent system. Totally passive, if an attempt is made to start the vehicle without the proper key, the ignition system is disabled
- A standard **engine cover convenience console** includes such handy features as dual auxiliary power outlets, dual cup holders, a glove box and a map net
- Standard **air conditioning** uses CFC-free refrigerant which does not contribute to ozone depletion
- Standard **Scotchgard™ Protector** helps protect cloth seating surfaces and floor coverings from stains and makes cleanups easy
- Standard **intermittent variable wipers** allow the driver to match wiper speed with weather conditions for improved visibility
- Standard **underseat heat ducts** provide precise temperature control to help make center- and rear-row passengers comfortable
- Standard **passenger assist handles** help make vehicle entry and exit easy
- Standard **wide-opening rear and side doors** make loading and unloading easy
- Standard **door map pockets** provide convenient storage space
- A standard **ribbed load floor** on Cargo Van models helps make sliding heavy cargo easy
- **Tilt-Wheel™ Adjustable Steering**



## INTERIOR FEATURES (contd.)

- **Column**, standard on LS and LT and optional with standard trim, tailors the wheel to the most comfortable, individualized steering position
- **Rear compartment convenience net**, standard on LS and LT, helps prevent groceries and other small cargo items from sliding around
- A **Remote Keyless Entry system** (included with LT models, optional with LS, base (1SB) and Astro Cargo Van), transmits a uniquely coded high-frequency radio signal to activate power lock/unlock functions, as well as illuminated entry
- **HomeLink 3-channel transmitter**, optional on LS and LT models with available roof console, memorizes the activation codes for as much as three remote-control devices (such as garage door, gate and security lights), reducing clutter in the vehicle.

## Audio Systems

While it's impossible to forecast everyone's musical tastes, Astro offers a sound system with the technology and features designed to complement all varieties of music, from jazz to country and in-between. Uplevel cassette and compact disc player systems feature speed-compensated volume, which automatically compensates for road noise by adjusting the audio volume to the vehicle's speed, as well as automatic tone control, which sets equalizer levels with one touch for talk and a variety of music programs.

Center-row radio controls are available with the uplevel cassette and dual playback cassette/compact disc player systems. This handy feature, which includes dual audio controls and dual headphone jacks, allows center-row passengers to listen to a different music source (radio and cassette tape or compact disc, depending on sound system selected) at a different volume than front-seat passengers.

## Available Sound Systems Include:

- **Electronically tuned AM/FM stereo** with seek-scan, digital clock and six-speaker system is standard on all models
- **Electronically tuned AM/FM stereo with cassette player**, seek-scan and digital clock is available on all models
- **Electronically tuned AM/FM stereo with cassette player**, speed-compensated volume, automatic tone control, seek-scan, digital clock, TheftLock security feature and eight-speaker system is optional on all models\*
- **Electronically tuned AM/FM stereo with compact disc player**, seek-scan, digital clock, automatic tone control, speed-compensated volume, TheftLock and eight-speaker system is optional on all models\*
- **Electronically tuned AM/FM stereo with cassette player, compact disc player**, seek-scan, digital clock, automatic tone control, speed-compensated volume, TheftLock and eight-speaker system is optional on all models.\*

\*Cargo Van models offer four front-door speakers and rear speaker wiring.

## Seats

Astro features a number of seating arrangements designed to accommodate as many as eight passengers, depending upon seating configuration and model chosen. Front passengers are protected by lap and shoulder safety belts and head restraints, while passengers in the intermediate and rear bench seats have lap safety belts for all passengers and shoulder safety belts and head restraints for the outboard seating positions.

Integrated child safety seats are available for the intermediate seat's two outboard positions (optional base and on LS).

Astro LT models have available Special Leather seating surfaces (Medium Gray and Neutral only).

## All-Wheel Drive ... On A Van?

All-weather traction isn't the exclusive domain of 4x4 sport utilities and pickups. The available All-Wheel-Drive is just one of the factors that help make this midsize van so versatile.

Under normal road conditions, the All-Wheel-Drive Astro provides full-time regulation of power flow to all wheels. As it senses road conditions, the system automatically transfers torque to front or rear wheels best able to provide traction.

## Astro Drivers Aren't Left In The Dark

Astro interior lighting automatically stays on briefly after the last door is closed, or until the ignition key is turned.



## 1998 Astro

### Many Astro Owners Enjoy going Dutch

For those looking for a different kind of look and function, Astro is available with optional rear Dutch doors — split-panel doors below a one-piece liftgate window. Dutch doors offer all the versatility of a double rear door plus the enhanced visibility of a full rear window.

Operation is easy with the electric release and gas struts on the liftgate window. An intermittent rear wiper/wet-arm washer is included with the Dutch doors option and a rear defogger is optional.

### A Shining Example of Astro Value

New for 1998, Astro features an improved clearcoat paint (interim availability) that helps protect the exterior against environmental damage.

Is it really better than last year's model? Yes. The exterior of Astro now has an even greater ability to resist water-spotting, acid rain and environmental-etch damage. And, that adds significantly to the overall long-lasting durability Astro owners enjoy.

### INTERIOR FEATURES (contd)

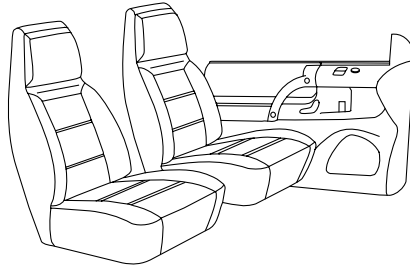

- Front high-back reclining Custom Vinyl bucket seats with adjustable 3-passenger center-row bench seat — standard on Astro Passenger Van with standard trim and Cargo Van (which includes only front seats).

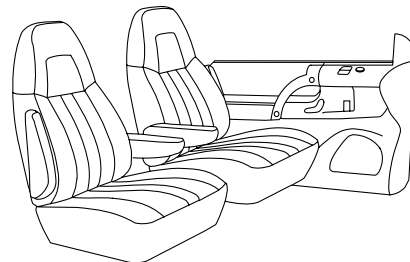

- Front high-back reclining Custom Cloth adjustable bucket seats with folding integral armrests and adjustable 3-passenger center- and rear-row bench seats — standard on LS, available with standard trim and on Cargo Van (front seats only).

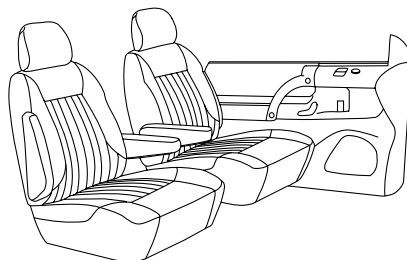

- Front reclining Special Cloth or Special Leather high-back bucket seats with folding integral armrests and adjustable headrest. Split-back center- and rear-row seats with fold-down center console, convenience tray and cup holders — standard on LT in Special Cloth, optional on LT with Special Leather seating surfaces.

### Alternate Seating Packages

- ZP7 7-passenger seating includes:  
4 high-back reclining bucket seats  
3-passenger adjustable rear-row seat.
- ZP8 8-passenger seating\* includes:  
2 high-back front reclining bucket seats and 2 3-passenger adjustable rear bench seats.\*

\*2 split-back rear bench seats with LT trim.

### Interior Colors



- Astro now features Medium Gray as an interior color choice. Other colors include:

- Navy
- Neutral
- Ruby.†

†Not available on standard Astro with 5-passenger seating.

### ASTRO EXTERIOR FEATURES

The exterior of Astro is designed for long-lasting attractiveness. Several corrosion protection techniques are employed to help ensure that the exterior will look like new for years to come.

- Two-side galvanized steel is used for all major exterior body panels (except the roof, where it is not needed) to help prevent surface rust due to minor chips and scratches.
- The Astro body, door and hood receive further corrosion protection from a seven-stage zinc phosphate wash and zinc-rich corrosion-resistant primer.
- Special sealers are applied to body seams for added corrosion protection before final assembly.
- All lower-body panels (except cladded models) receive a urethane anti-chip coating for added protection against stone damage and road debris, and hot wax is sprayed on the underbody.
  - An aluminized stainless-steel muffler and tailpipe provide enhanced durability.



## EXTERIOR FEATURES (contd.)

### Other Features Include:

- Astro Passengers models with YF7 and standard trim have a smooth front fascia and rear bumper, painted body-color
- Dramatic styling is provided by body-side cladding (standard on LS and LT; optional on Cargo Van models with YF7 Upfitter Package)
- Standard Solar-Ray tinted glass improves interior comfort and enhances protection against ultraviolet and infrared solar rays (deep tint on LS and LT models)
- The spare tire is mounted under the body to increase interior room and includes a winch-type carrier to help lower or raise the spare easily into its storage position.

## Exterior Paint

Standard basecoat/clearcoat paint on Astro resists fading and provides a high-gloss shine for long-lasting exterior beauty.



- Astro now features etch-resistant clearcoat paint (interim availability) that helps reduce damage caused by water-spotting, acid

rain and environmental etch. This clearcoat finish is used with all colors — solids and metallics.



## Exterior Colors

### New Paint Colors For '98:

- Medium Cadet Blue Metallic
- Dark Copper Metallic
- Dark Forest Green Metallic.

### Other Colors:

- Light Autumnwood Metallic
- Ivory White
- Teal Blue Metallic
- Cherry Ice Metallic
- Dark Purple Metallic

- Silvermist Metallic
- Light Carmine Red Metallic.

## DESIGN AND MANUFACTURING

Astro is manufactured at a General Motors assembly plant in Baltimore, Maryland. There, a precise combination of design technology, sophisticated assembly and statistical process control team up to assure Astro quality. Extensive use of robotics in welding, painting and other areas provide a high degree of production consistency. A computerized torque monitoring system, which verifies the correct tightening of critical nuts and bolts in the assembly process, is one of many advanced automated processes. These and other high-tech production methods translate into snug fits throughout the body, strong, seamless welds and a rich, superb-quality paint finish.

## BODY STRUCTURE

- Astro has a **unibody (integral frame) structure** that incorporates a partial front ladder-type stub-frame with the floor panels, adding rigidity without excessive weight. This design maximizes strength and payload capacity.
- The underbody, right- and left-side panels, roof panel and front end are made from **single-piece stampings**, for increased structural rigidity.
- **Single-piece construction** of the front-door frames, window frames, side- and rear-door openings protects against corrosion by eliminating vulnerable seams.
- Some parts — such as the radiator coolant reservoir, the windshield washer reservoir and the fuel tank shield — are composed primarily of plastic resin and are labeled to facilitate recycling.

## ENGINE

## Not Enough Time On Your Hands?

Let Astro help give you some of your time back. The standard Vortec 4300 V6 SFI offers a variety of time-saving (and cost-reducing), extended maintenance features that make owning Astro easy.

- Platinum-tip spark plugs give Astro the ability to travel up to 100,000 miles before the first scheduled tune-up.\*
- Extended-life coolant doesn't need to be changed up to 5 years or 150,000 miles, whichever comes first.\*
- There is no need to check engine timing.
- A single accessory drive belt helps reduce replacement costs over traditional belt designs.

### Other Astro "Easy-To-Own" Features Include:

- An aluminized stainless-steel muffler and tailpipe that provide long-lasting durability
- **Long-life automatic transmission** fluid will not need to be replaced for at least 100,000 miles under normal operating conditions\*
- Scotchgard™ Protector that helps resist stains on cloth and floor carpeting to make cleanups quick and easy
- Genuine Customer Care — Bumper to Bumper 3-year/36,000-mile limited warranty, 24-hour Roadside Assistance and, at participating dealerships, Courtesy Transportation.

\*Maintenance needs vary with different uses and driving conditions. See owner's manual for more information.



## Transmission Fluid? Don't Give It A Second Thought

Chevrolet automatic transmissions like the 4L60-E are "lubed for life," thanks to extended-life transmission fluid. This fluid should never need changing under normal operating conditions since it features a special additive that resists oxidation, provides outstanding friction characteristics and is compatible with the wide range of materials used in today's transmissions. Even the change interval for severe service — 50,000 miles — is three times that of its predecessor fluid.

## Where'd That Jerk Go?

Chevrolet automatic transmissions like the 4L60-E provide owners with a smooth driving experience.

There was a time when a smooth driving experience was reserved for luxury vehicles only, and certainly not to be expected in a van. No longer. Now, thanks to transmissions like the 4L60-E, electronic shift control helps reduce what some used to call a "somewhat jerky" operation. The electronic control makes possible very smooth shift patterns at all vehicle speeds.

So, whether the mission is taking the versatile Astro out for a family drive, or hauling a load of heavy thingamajigs across town, the 4L60-E helps assure a smooth ride.

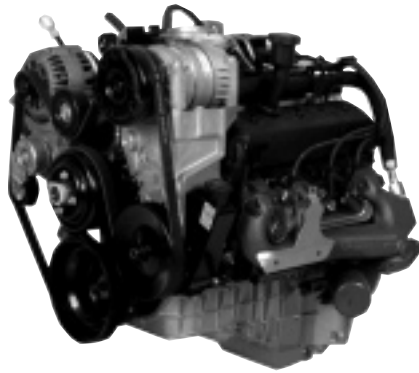

## Vortec 4300 V6 Engine (L35)

A Vortec 4300 V6 engine with Sequential Fuel Injection (SFI) is standard on Astro. This refined V6 is one of the most advanced engines in its class. It provides:

- 190 horsepower at 4400 rpm
- 250 lb.-ft. of torque at 2800 rpm.

### Extended-Life Service Items Include:

- **Platinum-tip spark plugs** for extended service intervals\*
- No need to check **engine timing** — ever
- **Extended-life coolant** good for as long as 5 years or 150,000 miles, whichever comes first\*
- **Single accessory drive belt** helps reduce replacement costs compared to traditional belt designs.

\*Maintenance needs vary with different uses and driving conditions. See owner's manual for more information.

## ON-BOARD DIAGNOSTICS SECOND GENERATION (OBD II)

On-Board Diagnostics for Astro is highly sophisticated, thanks to OBD II (On-Board Diagnostics Second Generation), a 1996 federal mandate.

- The system can mean faster, repairs for consumers. Take better engine diagnosis, for example. In low-level engine misfire, bad fuel, improper maintenance, cracked sparkplug insulation or plugged fuel injectors can all lead to a misfire diagnosis that's picked up by OBD II.

- OBD II functions by using a Vehicle

Control Module (VCM) to monitor fuel delivery, ignition timing and the emissions system to detect deterioration or malfunction.

- If a problem is detected, a Diagnostic Trouble Code (DTC) is stored and indicates the type of fault detected.
- The VCM stores and retrieves diagnostic messages to help technicians fix problems quickly and accurately.
- The VCM alerts the driver by illuminating the "Service Engine Soon" light when it detects a deterioration in the performance of any of the monitored components.
- Unlike first-generation systems that signaled only system failures, OBD II alerts the driver to have the vehicle serviced before experiencing a possible breakdown or incurring more expensive repairs.

## SEQUENTIAL FUEL INJECTION (SFI)

Sequential Fuel Injection, standard on all 1998 Astro models, is a far cry from yesterday's fuel-control systems, such as Electronic Fuel Injection or Multi-Port Fuel Injection. SFI optimizes fuel economy, power output and the ability to meet today's stringent emissions control requirements.

- SFI's secret is its high precision fuel control which uses one injector and nozzle per cylinder for optimum cylinder-to-cylinder fuel distribution.
- Each injector is fired sequentially and timed to the intake cycle for accuracy and metering control. (With non-SFI engines, fuel is typically injected twice per cycle or once per crankshaft revolution through all injectors at the same time. With SFI, the timing is much more precise, leading to performance improvements across the board.)

## SEQUENTIAL FUEL





### INJECTION (SFI) (contd.)

- A mass airflow meter constantly measures the engine's air requirements under varying conditions, such as changes in load, altitude and temperature. In an SFI system, the mass airflow meter is essential for accurate fuel delivery.
- The injector nozzle's design and optimum location produce an effective spray pattern that contributes to the engine's smooth idle and impressive fuel efficiency.

### TRANSMISSION

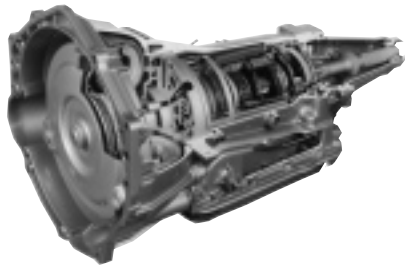

#### 4L60-E 4-Speed Electronic Automatic Transmission

GM's 4L60-E 4-speed automatic Overdrive transmission is standard equipment on Astro. The 4L60-E's "intelligent" electronic controls allow the transmission to match the engine's performance, delivering outstanding fuel efficiency.

- New is a **two-piece transmission case** that reduces vibration and noise.
- A new, **electronically controlled torque converter clutch** helps improve operating efficiency and driveability.
- A **deeper transmission oil pan** improves overall transmission durability and fluid life.

- The 4L60-E's **wide range of gear ratios** enhances both performance and fuel economy. The 3.06:1 first-gear ratio provides high torque multiplication for initial acceleration. The Overdrive 0.70:1 fourth gear lowers engine rpm at highway speeds, providing enhanced fuel economy and minimizing wear.
- The 4L60-E features electronic controls designed to provide precision and flexibility. The **Powertrain Control Module (PCM)** measures key vehicle input, including throttle position, vehicle speed, gear range, temperature and engine load. Four solenoids that are connected to the PCM control shift points and shift smoothness.
- The PCM acts as an interface between the engine and transmission to provide the feel of a **virtually "seamless" powertrain**.
- **Shift timing** is controlled electronically by signals sent to the valve body's shift solenoids, which activate the shift valves and execute the gear changes.
- A **brake/transmission shift interlock** is standard on Astro. The interlock requires the driver to apply the brake pedal to shift out of Park.
- A **second-gear start feature** provides an extra measure of control in hazardous driving conditions. The driver can reduce torque to the drive wheels by moving the gear selector to the Drive 2 position, thereby increasing control during initial acceleration on slippery surfaces.
- **4L60-E is factory-filled with long-life automatic transmission fluid** will not need to be replaced for at least 100,000 miles under normal operating conditions\*

\*Maintenance needs vary with different uses and driving conditions. See owner's manual for more information.

### ABS — Unlearning Old Habits

Buying a vehicle with **anti-lock brakes may require drivers, unfamiliar with this feature, to "unlearn" past braking habits.** Drivers, accustomed to traditional brake systems, have been taught to "pump" the brake pedal when braking hard on slippery surfaces to keep the car's wheels from locking up. With ABS, the system was designed to "pump" the brakes faster than is manually possible, automatically adjusting the brake pressure to the wheels independently to avoid wheel lockup. All the driver has to do is keep firm pressure on the brake pedal. To become familiar with the system, drivers should take the vehicle to an unoccupied parking lot (preferably one with slick pavement) and practice sudden hard-braking maneuvers to get a feel for the system.



## GM Mobility Program

Chevrolet recognizes the importance of mobility to everyone's life and, therefore, offers financial assistance to persons with disabilities through the General Motors Mobility Program. This program can provide financial assistance — as much as \$1,000 — toward the cost of any aftermarket adaptive equipment for drivers or passengers and/or vehicle “alerting devices” for deaf and hearing-impaired drivers. A special feature of the program is single-transaction GMAC financing for the vehicle and its adaptive aids. Further details are available by calling the GM Mobility Assistance Center at 1-800-323-9935. The hearing impaired can contact the Customer Assistance Center at 1-800-TDD-CHEV.

## Sarah Will Woman's Sport Foundation

As a further promotion of the General Motors Mobility Program, Astro is a proud sponsor of the Sarah Will Woman's Sport Foundation, a group dedicated to providing competitive athletic challenges to physically handicapped. Sarah Will is a skier and a member of the Barrier Breakers. Adaptively equipped Astro models are used for transportation to different athletic events.

## SUSPENSION

### Front

In keeping with its versatile nature, Astro offers different suspensions tailored to specific customer needs.

- The **torsion bars** on All-Wheel-Drive models use micro-alloyed spring steel that eliminates torsion bar adapter tubes — providing low mass and contributing to overall fuel economy.
- A **fluid drain plug** on the differential carrier makes service easy.
- All-Wheel-Drive models feature **upper and lower control arms, a stabilizer bar and torsion bars**. The torsion bars are computer-selected to optimize ride and handling.
- Rear-wheel-drive models feature an **independent front suspension** with upper and lower control arms, a stabilizer bar and computer-selected, friction-free coil springs.
- Specially tuned **32mm deflected disc shock absorbers** are standard on RWD and AWD models.

### Rear

- **Rear axle shafts** are hardened for fatigue resistance and durability.
- **Variable-rate, steel multi-leaf rear springs** provide a smooth ride and minimize jounce.  
All-Wheel-Drive models are available with two axle ratios:
  - 3.42:1 for mid-range towing needs
  - 3.73:1 for maximum torque and towing capability.Three axle ratios are available for rear-wheel-drive Astro models:
  - 3.23:1 for maximum fuel economy
  - 3.42:1 for mid-range towing needs
  - 3.73:1 for maximum torque and towing capability.

## STEERING

Astro features standard Electronic Variable Orifice (EVO) steering. EVO is an electronically controlled power steering system that improves steering ease at lower vehicle speeds (e.g., parking). At higher vehicle speeds, steering effort reverts to normal levels for better on-center feel.

## BRAKES

Power front disc/rear drum brakes are standard on Astro.

- Large (11.5-inch diameter AWD; 11.8-inch RWD) **ventilated front rotors** provide excellent brake cooling.
- **Audible pad-wear sensors** alert the driver when brake pad maintenance is needed. GM's award-winning ABS VI anti-lock brake system is standard equipment. Some things to keep in mind about anti-lock brakes:
  - ABS helps maintain steering control during severe braking situations and minimizes wheel lockup on most slippery surfaces. All the driver has to do is firmly hold the brake pedal down and steer.
  - ABS can adjust brake pressure by modulating the brakes several times per second, at a rate even the most skilled drivers can't duplicate.
  - The system automatically adjusts the brake-line pressure at the wheels. Drivers should not “pump” the brakes in emergency braking situations. Rather, they should maintain constant pressure on the brake pedal, allowing the system to work effectively.



## WHEELS AND TIRES



- 15" standard steel, painted Argent with bright hubcap.



- 15" x 6.5" styled-steel, painted (standard with 1SB, optional with standard trim and on Cargo Van).



- 15" x 6.5" chrome-cladded styled-steel (standard on LS with 1SC, optional on other models).



- 15" x 6.5" brushed aluminum (optional with standard trim, Cargo Van with YF7 Upfitter Package and LS with 1SD and LT).

## GENUINE CUSTOMER CARE

Chevrolet owners are covered by Genuine Customer Care, a comprehensive owner protection plan that includes the following:

### Bumper to Bumper Warranty

The GM 3-year/36,000-mile (whichever comes first), no-deductible, limited warranty covers repairs for all Chevrolet cars, including labor and parts, to correct any defects in material or workmanship occurring during the warranty period. Warranty features include air conditioning repair, tires, towing, no-cost warranty transfer and 6-year/100,000-mile (whichever comes first) sheet-metal rust-through protection. There also is emissions control system coverage, which varies by geographic location. The only item not covered by the warranty is normal maintenance.



**COURTESY TRANSPORTATION**  
**Courtesy Transportation**  
 Customers who purchase or lease a Chevy Astro are eligible for Courtesy Transportation (at no charge) when their vehicles are left at a participating dealership for repairs covered under the 3-year/36,000-mile Bumper to Bumper Limited Warranty. Courtesy Transportation, at participating dealers only, may include shuttle service, expense reimbursement, or, if the repairs require leaving the vehicle overnight, a vehicle rental. Owners should see their dealer for details.

**24-HR. ROADSIDE ASSISTANCE**  
**24-Hour Roadside Assistance**  
 Lost? We'll help you find your way. Locked out? We'll get you back in your Astro. Out of gas? We'll get you gas. Roadside Assistance is provided via a toll-free number 24 hours a day, 365 days a year. Roadside Assistance is offered in two levels of service, Basic Care and Courtesy Care.

**Roadside Basic Care** covers you as long as you own your Astro, and provides:

- Free towing for warranty repairs (to closest dealer)
- Over-the-phone basic technical advice
- Available dealer services at reasonable costs (i.e., wrecker services, locksmith/key service, glass repair, etc.).

**Roadside Courtesy care** is available to you for a period of three years or 36,000 miles (whichever comes first), and provides:

- Free towing (to closest dealer)
- Free locksmith/key service (when keys are lost on the road or locked inside)
- Free flat tire service, jump start, fuel delivery.

*Important — a word about this document: We have tried to make this document as comprehensive and factual as possible. We reserve the right, however, to make changes at any time, without notice, in colors, materials, equipment, specifications, models and availability. Some information may have been updated since the time of printing, June 1997. A note about air bags: Always wear safety belts, even with air bags. General Motors, GM, the GM Emblem, Chevrolet, the Chevrolet Emblem, Astro, Chevy Van, ETR, Solar-Ray, and TheftLock are registered trademarks and Chevy, Chevy Express, Passlock®, Venture and Vortec are trademarks of the General Motors Corporation. Scotchgard is a trademark of the 3M Corp. Homelink is a registered trademark of the Prince Corp. ©1997 General Motors Corporation. All rights reserved. Some artwork contained within this text is for representation purposes only.*

## History (By Model Year)

Introduced in 1985 as a "mid-size" alternative to minivans.

- 1986 — Throttle-body fuel injection on 4.3 Liter V6.
- 1987 — New Touring Package; serpentine belt engine accessory drive.
- 1988 — Anti-corrosion improvements.
- 1989 — Rear-wheel anti-lock brakes and electronic speedometer; Goodyear GT+4 tires available.
- 1990 — All-Wheel-Drive Passenger and Conversion Vans; extended wheelbase models debut; four-wheel anti-lock brakes; increased standard equipment for all trim levels.
- 1991 — 4.3-Liter V6 engine with EFI increased to 170 horsepower.
- 1992 — Enhanced-4.3 Liter Vortec V6 engine — optional on 2WD, standard on AWD; optional Dutch doors.
- 1993 — Electronically-controlled 4L60-E transmission introduced.
- 1994 — Side-door beams; driver air bag; CFC-free R-134a air conditioning refrigerant introduced.
- 1995 — New front-end appearance; standard enhanced Vortec 4.3L-V6 with CPI.
- 1996 — New interior; passenger-side air bag added; improved Vortec 4300 V6 engine.
- 1997 — Daytime Running Lamps (DRL); Electronic Variable Orifice (EVO) power steering.



# 1998 Astro Feature Availability

	Standard	LS	LT	Cargo Van
<b>INTERIOR</b>				
Air Bags - Dual	S	S	S	S
Air Conditioning - Front, With CFC-Free Refrigerant	S	S	S	S
- Front and Rear	O	O	O	NA
Convenience Group - Tilt-Wheel™ & Speed Control	O	S	S	O
- Power Windows	O	S	S	O
Door Beams - Side Impact	S	S	S	S
Door Trim - Driver and Passenger, color-keyed cloth/carpet	NA	S	S	NA
Headliner - Color-Keyed Cloth	S	S	S	NA
Gauges - Fuel level, Odometer, Oil Pressure, Speedometer, Temperature Gauge, Trip Odometer, Voltmeter	S	S	S	S
Lights, Interior - Delayed entry	S	S	S	O
Locks - Power Door	O	S	S	O
Passlock® Theft-Deterrent System	S	S	S	S
Scotchgard™ Protector	S	S	S	NA
Seating - 5-Passenger	S	NA	NA	NA
- 8-Passenger	O	S	S	NA
- 7-Passenger	O	O	O	NA
- 2-Passenger	NA	NA	NA	S
Seats - Vinyl Front Reclining Buckets & Center Bench	S	NA	NA	NA
- Cloth Front Reclining Buckets & Two Bench	O	S	NA	NA
- Special Cloth Front Reclining Buckets & Two Split-Bench	NA	NA	S	NA
- Special Leather Front Reclining Buckets & Two Split-Bench	NA	NA	O	NA
- Vinyl Front Reclining Buckets	NA	NA	NA	S
Seat Package - Armrests, Map Pocket, Lumbar Support <sup>1</sup>	O	S	S	O
Steering Wheel - Black Four-Spoke	S	S	NA	S
- Black Leather Wrapped	NA	O	S	NA
Stereo - ETR AM/FM with Digital Clock	S	S	S	S
- ETR AM/FM with Cassette Player And Digital Clock	O	O	O	O
- ETR AM/FM with Cassette And Compact Disc Players	O	O	O	O
- Rear Seat Radio Controls and Jacks	NA	O	O	NA
Storage Compartment - Left Rear Quarter, Third Seat Area	S	S	S	NA
Sunshades - Cloth w/Map Bands, Extenders	S	NA	NA	S
- Cloth w/Lighted Mirrors, Extenders	NA	S	S	NA
- Vinyl Color-Keyed w/Map Bands	NA	NA	NA	S
Warning Tone - Headlamps-On Warning Buzzer	S	S	S	S
Windows - Swing-Out on Sliding Door, LF Quarter Panel	S	S	S	O
Windows - Swing-Out on Rear Door	NA	S	S	O
Wipers - Intermittent Variable	S	S	S	S
<b>EXTERIOR</b>				
Daytime Running Lamps (DRL)	S	S	S	S
Doors - Sliding RH Side, RH and LH Rear Loading	S	S	S	S
Doors - Rear Dutch w/Liftglass	O	O	O	O
Mirrors - Below Eyeline Foldaway, Black	S	NA	NA	S
- Below Eyeline Electric Remote Control, Black	O	S	S	NA
Tires - P215/75R-15 All-Season Blackwall	S	S	S	S
- P215/75R-15 All-Season White Lettered	O	O	O	O
Wheels - Steel 15" x 6" Silver Painted w/Black Center Cap	S	NA	NA	S
- Styled-Steel 15" x 6" Silver Painted	O	O	NA	O
- Styled-Steel 15" x 6" Chrome-Cladded	O	S	O	O
- Brushed Aluminum 15" x 6"	NA	O	S	NA
<b>FUNCTIONAL</b>				
Brakes - 4-Wheel Anti-Lock (ABS)	S	S	S	S
- Power, Front Disc/Rear Drum	S	S	S	S
Cargo Capacity - Up To 170.4 cu. ft. <sup>2</sup>	S	S	S	S
Engine - Vortec 4300 V6 SFI	S	S	S	S
Fuel Capacity - 25-Gallon	S	S	S	S
Remote Keyless Entry	O	O	S	O
Suspension - Touring	O	O	O	NA
Trailer Capacity- 5500 lbs. <sup>3</sup>	O	O	O	O
Transmission - 4-Speed Electronically Controlled Automatic	S	S	S	S

S — Standard. O — Optional [some options may be available only as part of a Preferred Equipment Group (PEG)]. NA — Not available. 1 Available with cloth trim only. Included with standard trim PEG and ISC, LS, LT decor. 2 Cargo Van model and Passenger Van model when center- and rear-row seats are removed. 3 When properly equipped.

# 1998 Astro Specifications

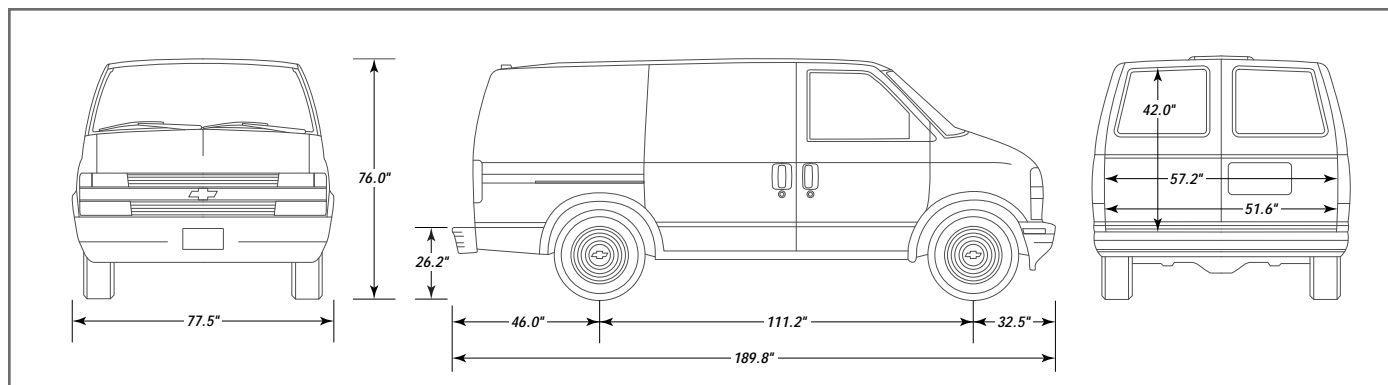

## MODEL AVAILABILITY

### Astro Van RWD/AWD

Passengers	5-8 (Passenger Van), 2 (Cargo Van)
Class	Midsized Van
Assembly Plant	Baltimore, Maryland
Primary Structure	Unibody, Integral Steel Stub Frame
Body Material	Two-Side Galvanized Steel (except roof)

## SPECIFICATIONS & CAPACITIES (inches, unless otherwise noted)

	RWD	AWD
<b>Exterior Dimensions</b>		
Wheelbase	111.2	111.2
Overall Length	189.8	189.8
Overall Height	76.0	76.0
Maximum Width	77.5	77.5
Ground to Rear Load Floor	26	26
Ground Clearance Front/Rear	6.8/7.4	6.8/7.4
<b>Interior Dimensions*</b>		
Headroom (front/mid./rear)	39.2/37.9/38.7	39.2/37.9/38.7
Legroom (front/mid./rear)	41.6/36.5/38.5	41.6/36.5/38.5
Shoulder Room (front/mid./rear)	64.0/67.1/67.1	64.0/67.1/67.1
Hip room (front/mid./rear)	64.9/50.9/57.1	64.9/50.9/57.1
<b>Capacities</b>		
Curb Weight (min.) (lbs.)	4185.5	4431.9
Maximum GVWR (lbs.)	5950	6100
Base Payload (std.) (lbs.)	1764.5	1668.1
Cargo Capacity (cu. ft.)	170.4	170.4
Max. Trailer Capacity (lbs.)	5500	5000
Fuel Tank Capacity (gal.)	25	25

\*Front interior dimensions also apply for Astro Cargo Van models.

## STEERING

	RWD	AWD
Type	Integral Power w/EVO	Integral Power w/EVO
Steering Ratio	16/14:1	16/14:1
Turning Diameter, Curb-to-Curb (ft.)	39.5	40.5



## 1998 Astro Specifications

### BRAKES

	RWD	AWD
Type	Hydraulic Power Front Disc/Rear Drum	4-Wheel ABS
Front Size (disc) (in.)	11.86 x 1.04	11.57 x 1.25
Rear Size (drum) (in.)	9.5 x 2.0	9.5 x 2.0
Booster Diaphragm	Hydro-Boost	Hydro-Boost
Parking Brake	Cable to Rear Wheels	Cable to Rear Wheels

### ENGINES

	L35
Type	Vortec 4300 V6
Block Material	Cast-Iron
Cylinder Head Material	Cast-Iron
Bore & Stroke (in./mm)	4.00 x 3.48/101.6 x 88.4
Displacement (cu. in./cc)	262/4300
Compression Ratio	9.2:1
Induction System	SFI
Valves/Cylinder	2
Lifters	Hydraulic Roller
Cam Drive	Chain
Horsepower @ rpm (SAE net)	190 @ 4400
Torque @ rpm (SAE net)	250 @ 2800
Redline (rpm)	5600
Recommended Fuel (min.)	87 Octane

### TRANSMISSIONS

Model Availability	RWD & AWD
Transmission Type	4-Speed Electronically-Controlled Automatic w/Overdrive & Torque Converter
1st	3.06
2nd	1.63
3rd	1.00
4th	0.70
Reverse	2.29

### CHASSIS

	RWD	AWD
Frame	Integral/Unibody; Partial Ladder-Type Frame Incorp. w/Floor Panels	Integral/Unibody; Partial Ladder-Type Frame Incorp. w/Floor Panels
Front	Independent w/Coil Springs	Independent w/Torsion Bars
Rear	Variable-Rate Steel Multi-Leaf Springs	Variable-Rate Steel Multi-Leaf Springs
Shocks, Front/Rear (mm)	32/32	32/32
Anti-Roll Bar, Front (mm)	32*	30
Rear Axle	Semi-Floating	Semi-Floating

\*RWD Astro Cargo Van front anti-roll bar is 28mm.

# 1998 Astro Specifications



## MILEAGE\*

Type Mileage:	4-Speed Automatic w/Vortec 4300 V6	4-Speed Automatic w/Vortec 4300 V6 AWD
City	16	15
Highway	21	19
Combined	18	17
Est. Cruising Range:		
City	400	375
Highway	525	475
Combined	450	425

\*Based on 1997 information.

## TRAILERING INFORMATION

	RWD	AWD
Trailer Classification	Medium	Medium
Gross Trailer Weight (lbs., up to)	5500	5000
Max Tongue Load (lbs.)	650	600

## WHEELS & TIRES

	RWD & AWD			
Type*	Steel	Styled-Steel	Chrome-Cladded Styled-Steel	Brushed-Aluminum
Size (in.)	15 x 6	15 x 6.5	15 x 6.5	15 x 6.5

\*15" x 6.5" Steel Wheels standard with base-level models; 15" x 6.5" Styled-Steel Wheels standard on Astro LS; 15" x 6.5" brushed-aluminum wheels standard on Astro LT. All uplevel wheels are optional on base-level model.

Tire Type	All-Season Steel-Belted Radial Blackwall
Tire Size	P215/75 R-15
Optional Tire	P215/75 R-15 White-outline lettered or P235/65R-15 White-outline lettered Touring (w/FE2 Touring Suspension Package)

All specifications are preliminary and subject to change. Chevrolet Motor Division. June, 1997.





## Free Manuals Download Website

<http://myh66.com>

<http://usermanuals.us>

<http://www.somanuals.com>

<http://www.4manuals.cc>

<http://www.manual-lib.com>

<http://www.404manual.com>

<http://www.luxmanual.com>

<http://aubethermostatmanual.com>

Golf course search by state

<http://golfingnear.com>

Email search by domain

<http://emailbydomain.com>

Auto manuals search

<http://auto.somanuals.com>

TV manuals search

<http://tv.somanuals.com>