

C232B Clock Radio with Dual Alarm

FCC Warnings

Warning: Changes or modifications to this unit not expressly approved by the party responsible for compliance could void the user's authority to operate the equipment.

NOTE: This equipment has been tested and found to comply with the limits for a Class B digital device, pursuant to Part 15 of the FCC Rules. These limits are designed to provide reasonable protection against harmful interference in a residential installation. This equipment generates, uses, and can radiate radio frequency energy and, if not installed and used in accordance with the instructions, may cause harmful interference to radio communications. However, there is no guarantee that interference will not occur in a particular installation. If this equipment does cause harmful interference to radio or television reception, which can be determined by turning the equipment off and on, the user is encouraged to try to correct the interference by one or more of the following measures:

- Reorient or relocate the receiving antenna.
- Increase the separation between the equipment and receiver.
- Connect the equipment into an outlet on a circuit different from that to which the receiver is connected.
- Consult the dealer or an experienced radio/TV technician for help.

Introduction and Setup

Power

Plug the included AC/DC power adapter into the **DC POWER INPUT** on the dock and an AC power outlet to power the dock.

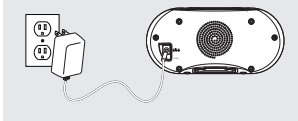

Battery Backup

The battery backup is intended for short power outages only. The clock radio's primary functions cannot run off of the battery backup alone.

Requires 2, AAA-size, batteries (not included)

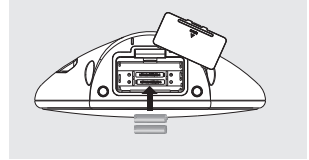

LED Display

PM Indicator
Lights when the time is in the PM.

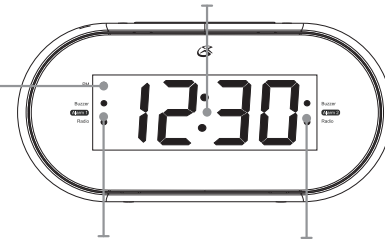

**Alarm 1 Buzzer/
Radio Indicator**
Lights when the alarm 1 is on and set to buzzer or radio.

**Alarm 2 Buzzer/
Radio Indicator**
Lights when the alarm 2 is on and set to buzzer or radio.

Dimmer
Press to dim the display.

Tuning/Min/Hour
Press to tune the radio.
Press to adjust the minute or hour when setting the clock or alarm.

Clock/Mem
In Off mode, press and hold to begin setting the time.
In radio mode, press to cycle through preset stations.

Snooze/Sleep
Press to snooze the alarm after it sounds. Press repeatedly to set the sleep timer.

Volume/AL1/AL2
Press to adjust the volume.
Press to begin setting Alarm 1 or Alarm 2.

Source/AL Off
Press and hold to turn off the radio.
Press to turn off the alarm.

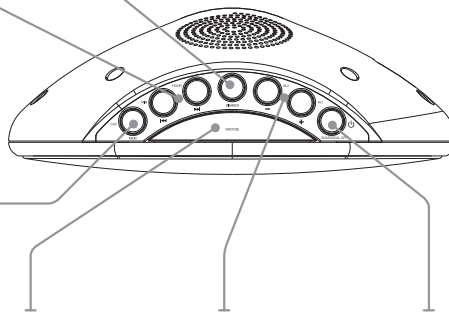

Clock and Sleep Timer

Setting the Clock

1. If in radio mode, press and hold the **Source/Al Off** button to turn the unit off.
2. Press and hold the **Clock/Mem** button until the display begins to blink, then release the button.
3. Press the **Hour** button to adjust the hour.

The PM indicator will light when the hour is set in the PM.

4. Press the **Min** button to adjust the minute.
5. Press the **Clock/Mem** button to finish setting the time.

Setting the Sleep Timer

1. Follow the instructions for [y](#).
2. Press the **Snooze/Sleep** button repeatedly to set the sleep timer (90, 80, 70, 60, 50, 40, 30, 20, 10 min or OFF).
3. Once the set sleep time has expired the clock radio will automatically power off.

Alarm

Setting the Alarm

1. If in radio mode, press the **Source/Al Off** button to turn the unit off.
2. Press and hold the **Al1** or **Al2** button until the display begins to blink, then release the button.
3. Press the **Hour** button to adjust the hour.

The PM indicator will light when the hour is set in the PM.

4. Press the **Min** button to adjust the minute.
- The Alarm 1 or Alarm 2 indicator will come on.*
5. Press the **Al1** or **Al2** buttons repeatedly to switch between Radio and Buzzer.

If the alarm is set to Radio, use the Vol+/- buttons to adjust the volume of the alarm.

6. Once the set alarm time is reached, the alarm will sound.

To set the other alarm, follow the above steps and choose the alarm not currently set.

Canceling the Alarm

1. Follow the instructions for [Setting the Alarm](#).
2. Press the **Al1** or **Al2** buttons repeatedly until the indicator is no longer lit.

Snooze and Alarm Reset

After the alarm sounds:

Press the **Snooze/Sleep** button to delay the alarm for an additional 9 minutes.

OR

Press the **Source/Al Off** button to turn the alarm off until the set alarm time is reached again.

Radio

Tuning the AM or FM Radio

1. Press the **Source/Al Off** button to turn the clock radio on.
2. Press the **Source/Al Off** button again to switch between the AM and FM radio mode.
3. Press the **Tun+** and **Tun-** buttons to adjust the radio to the desired frequency.
4. Press and hold the **Tun+** and **Tun-** buttons to search for the next available frequency.
5. Press the **Vol+/-** buttons to adjust the volume.
6. Press and hold the **Source/Al Off** to turn the radio off.

Saving a Station as a Preset

1. Follow the instructions for [Tuning the AM or FM Radio](#).
2. Tune to the desired station.
3. Press and hold the **Clock/Mem** button to save the current radio station as a preset.

Tuning to a Preset Radio Station

1. Follow the instructions for [Tuning the Radio](#) and [Saving a Station as a Preset](#).
2. Press the **Clock/Mem** button to cycle through preset radio stations.

Radio Reception

Adjust the position of the **FM Antenna** to improve FM radio reception.

An AM antenna is built into the clock radio. To improve AM radio reception, adjust the position of the clock radio.

International Support

To download this User's Guide in English, Spanish, or French, or to get answers to frequently asked questions, visit the support section at:

www.gpx.com

Para descargar este Manual del Usuario en inglés, español y francés, o para obtener respuestas a preguntas frecuentes, visite la sección de apoyo en

www.gpx.com

Pour télécharger ce guide de l'utilisateur en anglais, espagnol ou français, ou pour obtenir des réponses à des questions fréquemment posées, consultez la rubrique d'assistance sur

www.gpx.com



Free Manuals Download Website

<http://myh66.com>

<http://usermanuals.us>

<http://www.somanuals.com>

<http://www.4manuals.cc>

<http://www.manual-lib.com>

<http://www.404manual.com>

<http://www.luxmanual.com>

<http://aubethermostatmanual.com>

Golf course search by state

<http://golfingnear.com>

Email search by domain

<http://emailbydomain.com>

Auto manuals search

<http://auto.somanuals.com>

TV manuals search

<http://tv.somanuals.com>