

DG-5 The Digital Keyless Entry System Operation User's Manual

1. Features:

- ◆ 4 digit codes (5 digit codes available by special order)
- ◆ Tamper Switch Included
- ◆ Door Reed Switch Input for Anti-Trailing
- ◆ 10 user PINs
- ◆ Fully Programmable via keypad and master code
- ◆ Non-Volatile Memory
- ◆ Invalid PIN Lock-out

2. Specifications:

- ◆ Operating Voltage: 9~14 Vdc
- ◆ Current Draw: Average 20mA, Peak 70mA @ 12Vdc
- ◆ Input: One request-to-exit, and time out reed switch
- ◆ Relays: N.O./N.C./Com. Output (free voltage contact), 3A@ 125Vac or 30Vdc
- ◆ Case Material: ABS (UL94V0)
- ◆ Operating Temperature: -20~+70°C
- ◆ Ambient Humidity: 0~95% relative humidity non-condensing
- ◆ Visual Signals:
 - Green: Power on
 - Red: Relay activated
 - Yellow: Program Mode · Lock-out
- ◆ Factory Master Code: 1234
- ◆ Invalid PIN Lockout: System will shut down 60 seconds while 6 times of incorrectly password attempted.
- ◆ Relay Activation Time: (* 20)
 - Pulse mode : 1~99 seconds (01~99)
 - Latching mode (00)
- ◆ EPROM: Non-volatile memory, System will retain all programs and codes after a total loss of power.
- ◆ User PINs: (* 01~* 10) It is possible to program 10 different user PIN codes.

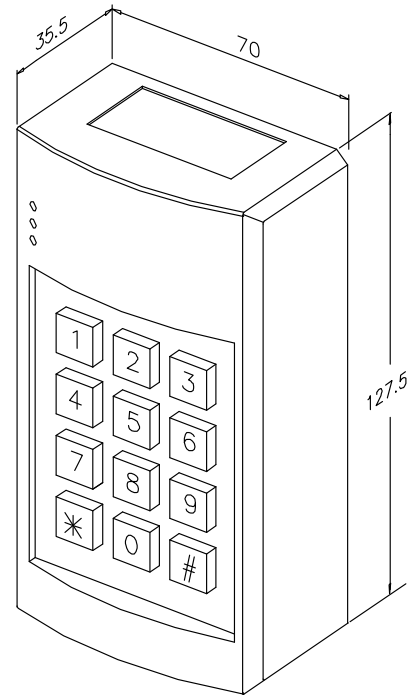

3. Program Instruction:

- ◆ **Enter Program Mode:**
 1. Enter the master code twice (Factory master is 「 1234 」)
 - 2 beeps and the Yellow LED will light up.
 - you are now in the "programming mode".
 2. **Note:** After 60 seconds if you have not entered any codes or data, the system will automatically exit from the programming mode. After 6 wrong attempts at the master code the lockout facility will operate.
- ◆ **Exiting from the program mode:**
 1. Press 「 # 」 to exit from the programming mode.

- Note:** After 60 seconds if you have not entered any codes or data, the system will automatically exit from the programming mode. After 6 wrong attempts at the master code the lockout facility will operate.

◆ **To Enter a User Code :**

Enter the Programming mode

- Enter the slot position code 「 *01~*10 」 →???? (user code 4 digit) → (beep) →enrolled→ Press # to exit from the programming mode, or program other operating.
- Note:** The codes"0000","1234" or master code are not be used for PIN code.

◆ **To Program Relocking Timer (relay) :**

Enter the Programming mode

- Press 「 *20 」 Followed by the number of seconds the relay should open→ 「 05 」 =5 seconds (01 ~99 = seconds) → (beep) →enrolled → Press 「 # 」 to exit from the programming mode, or program other operating.
- Enter 「 00 」 Sets the relay to latching mode. (Correct code entered opens the relay, and the relay stays open until the correct code is entered again).

◆ **To Delete a User Code :**

Enter the Programming mode→ Press the slot position code of your choice to delete (example "06") →Press 「 *06 」 → 「 0000 」 → (beep) →delete→Press 「 # 」 to exit from the programming mode, or programming other operating.

◆ **To Change the Master codes:**

Enter the Programming mode, Enter 「 *00 」 Followed by the new 4 digit master code→ (beep) →enrolled→Enter 「 # 」 to exit from the programming mode, or program other operating.

4. Wiring diagram:

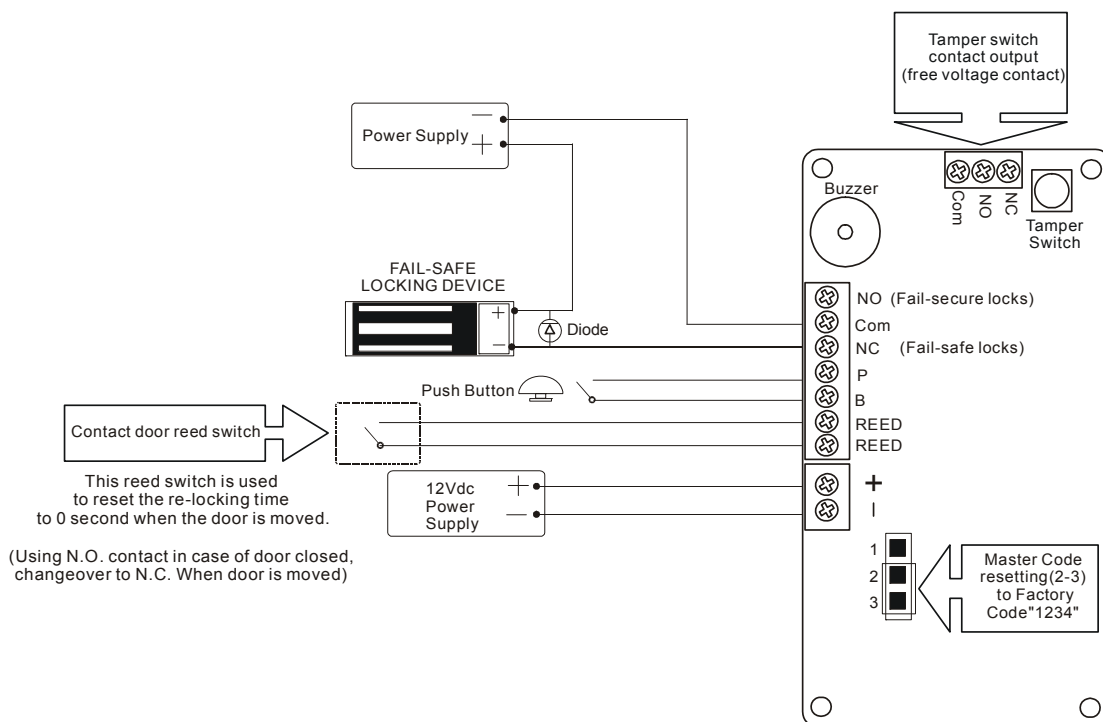

Note:

The varistor or diode must be connected across the lock terminal (electromagnet...) operated by the device. The varistor controls the overload produced by the strike coil (EMP).

Free Manuals Download Website

<http://myh66.com>

<http://usermanuals.us>

<http://www.somanuals.com>

<http://www.4manuals.cc>

<http://www.manual-lib.com>

<http://www.404manual.com>

<http://www.luxmanual.com>

<http://aubethermostatmanual.com>

Golf course search by state

<http://golfingnear.com>

Email search by domain

<http://emailbydomain.com>

Auto manuals search

<http://auto.somanuals.com>

TV manuals search

<http://tv.somanuals.com>