



UL Listed Certified for US and Canada
"Positive Pressure Fire Tests of Door Assemblies,"
ANSI/UL UL 10B and 10C,
uniform building code standard UBC 7-2 (1997).

● Features

- High reliability
- Offers up to 1200 LBS Holding Force.
- Fail- safe operation (Power to Lock).
- Five years warranty.
- Anodized aluminum housing.
- MOV provides spike and surge protection.
- Adjustable mounting plate for easy installation.
- Dual voltage 12 or 24 VDC (selectable).
- Anti-Residual magnetism designed.
- Full range of optional brackets available.

● Statement

The EM-1200 Series is high quality and safety range of standard fail-safe electromagnetic locks that is simply, works well in order to effectively secure with doors. The EM-1200 Series is surface mounted face to face locks offering up to 1200 pounds holding force with field selectable for 12V or 24V DC dual input voltage. This lock is recommended for applications which required higher levels of access and egress control and is suitable for fire doors and emergency exit doors.

It designed for single doors and are suitable for out-swing applications. Installation of in-swing door, narrow-style frames requires the used an additional bracket. With the accessories provided.

● Operating Features



EM-1200M: Bond sensor output & Status LED

Bond sensor is used to indicate the door status as in a locked or unlocked condition. Status LED is a visual feedback for user to give the true status of the lock at any time. Green light indicates the door is insecure

Bond sensor monitor output : SPDT rated: 3A@12VDC

● Specifications

- Voltage Tolerance: 15%
- Current Draw: 500mA@12Vdc, 250mA@24Vdc (at temperature 20C)
- Operating Temperature: -10~55C (14~131F)
- Humidity: 0~95% non-condensing.
- Lock's surface Temperature: (when the power is on): (current temperature +20C)
- Holding Force: Up to 1200 lbs (545 Kg)
- Dimensions:
 - Magnet:(L) 266(264), (W) 68, (D) 40 mm
 - Armature Plate:(L) 185, (W) 62, (D) 16 mm
 - Mounting Plate:(L) 266(264), (W) 40, (D) 5 mm
- Special Finishes for magnet and armature plate: Zinc
- Epoxy Potting Compound: E87252 (S), UL94V-0
- Weight (Approx.): 4.8 Kg

● Regular Installation

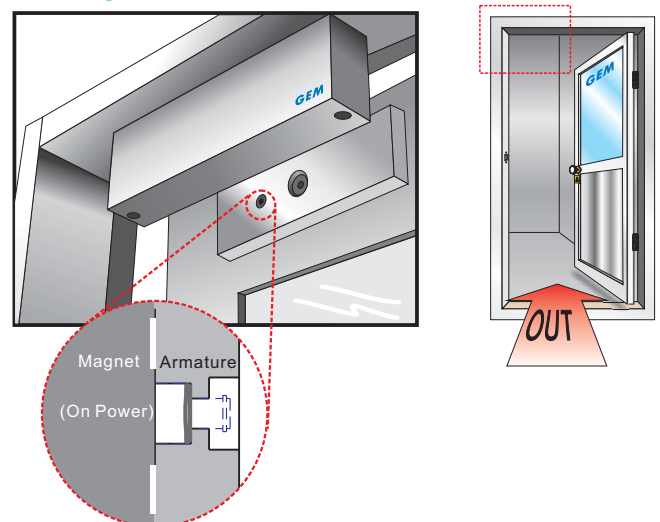

Unique Anti-Residual design

When the power is switched off, the holding force will be discontinuity and the bolt was installed in armature will pop

GIANNI INDUSTRIES, INC.

No. 13, Zhong Sing Road, Tu-Cheng Industrial Zone,
Tu-Cheng City, Taipei, Taiwan 23678
Tel: 886-2 2267 7986 / Fax: 886-2 2267 9876
E-Mail: info@gianni.com.tw
Website: gianni.tw
Copyright 2008 Gianni industries, inc. All rights reserved.
DM-CA-EM-1200 Ver. A Published on 2008.04.30



The products are manufactured under an ISO 9001 & QC 080000 Certified Quality Management Program environment back its product quality, performance and commitment to customer satisfaction.

Optional Brackets

The door swinging direction and the door frame header are used to determine whether the bracket is required and this identify is a measure of which brackets is suitable. Our optional brackets include L-bracket, LZ-bracket.

With L-bracket for narrow door frames

When "A" < 60 mm , must installed with "L" brackets.

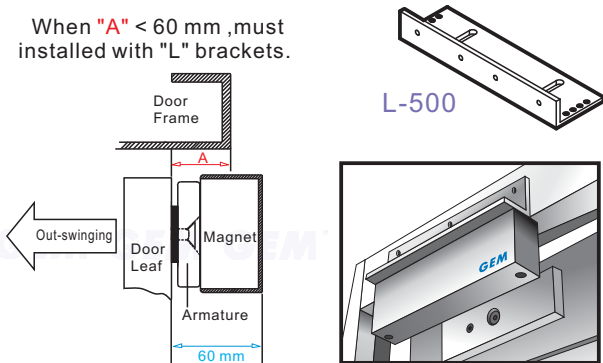

With LZ-bracket for in-swinging doors

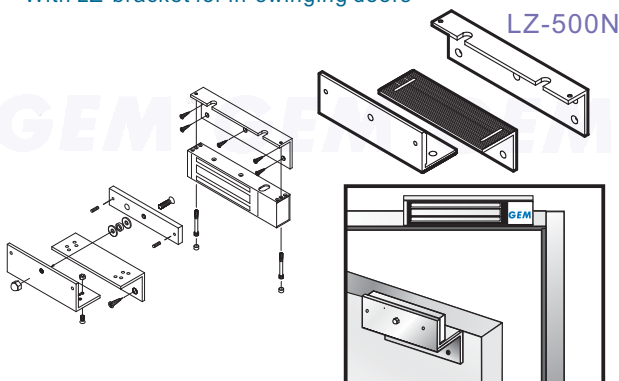

Warranty

The product is warranted against defects in material and workmanship while used in normal service for a period of 5 year from the date of sale to the original customer. The GEM policy is one of continual development and improvement; therefore GEM reserves the right to change specifications without notice.

GIANNI INDUSTRIES, INC.

No. 13, Zhong Sing Road, Tu-Cheng Industrial Zone,
Tu-Cheng City, Taipei, Taiwan 23678
Tel: 886-2 2267 7986 / Fax: 886-2 2267 9876
E-Mail: info@gianni.com.tw
Website: gianni.tw
Copyright 2008 Gianni industries, inc. All rights reserved.
DM-CA-EM-1200 Ver. A Published on 2008.04.30



The products are manufactured under an ISO 9001 & QC 080000 Certified Quality Management Program environment back its product quality, performance and commitment to customer satisfaction.

Free Manuals Download Website

<http://myh66.com>

<http://usermanuals.us>

<http://www.somanuals.com>

<http://www.4manuals.cc>

<http://www.manual-lib.com>

<http://www.404manual.com>

<http://www.luxmanual.com>

<http://aubethermostatmanual.com>

Golf course search by state

<http://golfingnear.com>

Email search by domain

<http://emailbydomain.com>

Auto manuals search

<http://auto.somanuals.com>

TV manuals search

<http://tv.somanuals.com>