



Patent:  
ZL 2006 2 0122522.X  
Nr. 20 2006 012 052.1  
M308308  
GB 06 1 6099.8  
06 07229 (France)

### ● Features

- Offers up to 800 LBS Holding Force.
- Anodized aluminum housing.
- Groove template & housing for easy installation.
- Dual voltage 12 or 24 VDC )selectable(.
- Anti-Residual magnetism designed.
- Complete mounting hardware included.

### ● Statement

The EM-NH350 electromagnet lock is an important mounting plate design breakthrough. The mounting plate is designed with a well engineered sliding mechanism that makes electromagnet considerably easy to clasp the mounting plate to allow security of use and maximize the ease of installation. Therefore, even if used for longer periods, the tricky innovation in its design will prevent the electromagnet of being falling when the screw are loosening up .

### ● Specifications

- Voltage Tolerance: 15%
- Current Draw: 500mA@12Vdc;250mA@24Vdc )at 20 degree centigrade(
- Operating Temperature from -10 to 55 degree centigrade
- Humidity: 0~95% non-condensing.
- Holding Force: Up to 800 lbs (363 Kg)
- Dimensions:
  - Magnet:(L) 265, (W) 52, (D) 29 mm
  - Armature Plate:(L) 185, (W) 45, (D) 14 mm
  - Mounting Plate:(L) 265, (W) 29, (D) 6.5 mm
- Finishes for magnet and armature plate: Zinc
- Epoxy Potting Compound: E87252 (S), UL94V-0
- Weight (Approx.): 3.0 Kg

### ● Operating Features



#### EM-NH350M: Bond sensor output & Status LED

Bond sensor is used to indicate the door status as in a locked or unlocked condition. Status LED is a visual feedback for user to give the true status of the lock at any time. Green light indicates the door is insecure

Bond sensor monitor output : SPDT rated: 3A@12VDC

### ● Special Mounting Plate design

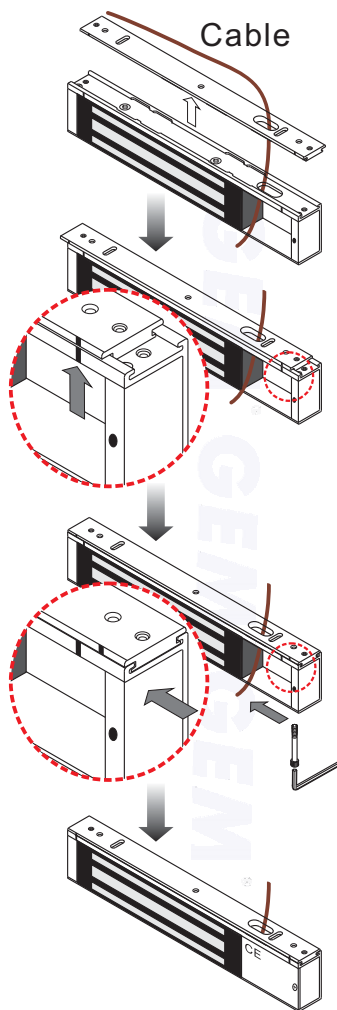

Fasten the mounting plate on the site then install electromagnet lock with power lead cable through mounting plates slot hole.

For assembling the mounting plate and the electromagnet lock into the groove, please make the mark on the mounting plate and the mark on the electromagnet lock itself to be a straight line for alignment. Either aligning from left side or from right side is feasible.

Slide the electromagnetic lock to fit with the mounting plate as the drawing. Once the correct position is encountered, use the Allen Wrench to fasten the fixing screws through the bottom of the electromagnet lock into the mounting plate.

After the electromagnet firmly assembled with the mounting plate, use the screws to fasten the lock on the site permanently.

## GIANNI INDUSTRIES, INC.

No. 13, Zhong Sing Road, Tu-Cheng Industrial Zone,  
Tu-Cheng City, Taipei, Taiwan 23678  
Tel: 886-2 2267 7986 / Fax: 886-2 2267 9876  
E-Mail: info@gianni.com.tw  
Website: gianni.tw  
Copyright 2008 Gianni industries, inc. All rights reserved.  
DM-CA-EM-NH350 Ver. D Published on 2008.08.18



The products are manufactured under an ISO 9001 & QC 080000 Certified Quality Management Program environment back its product quality, performance and commitment to customer satisfaction.

### Optional Brackets

The door swinging direction and the door frame header are used to determine whether the bracket is required and this identify is a measure of which brackets is suitable. Our optional brackets include L-bracket, LZ-bracket and U-bracket.

#### With L-bracket for narrow door frames

When "A" < 48 mm, must installed with "L" brackets.

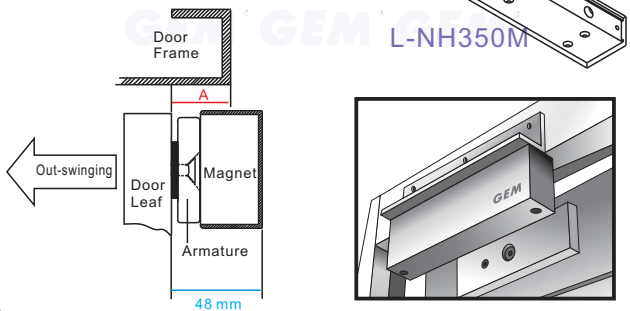

#### With LZ-bracket for in-swinging doors

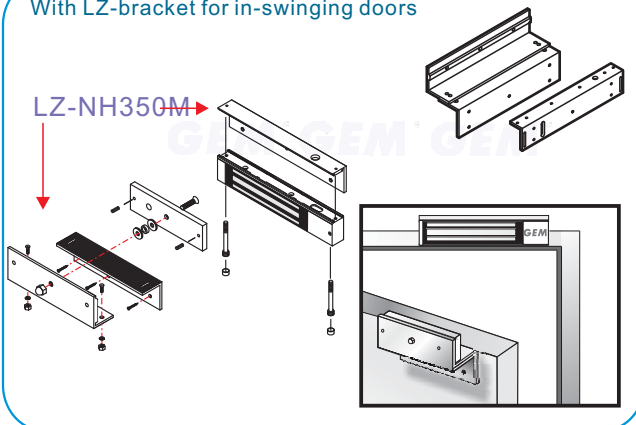

#### With U-bracket for frameless glass doors

UBK-010 For 10mm thickness of glass door  
UBK-012 For 12mm thickness of glass door

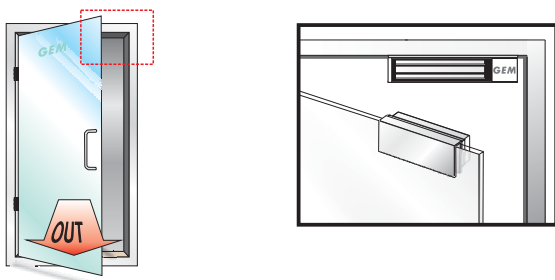

### Regular Installation

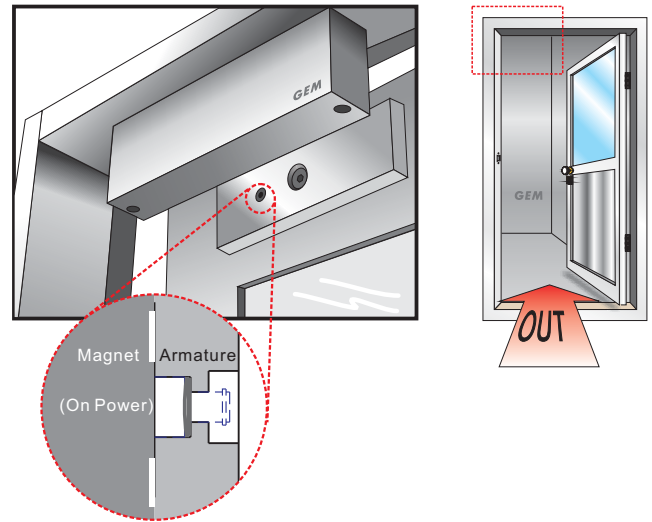

Unique Anti-Residual design

When the power is switched off, the holding force will be discontinuity and the bolt was installed in armature will pop

### Patent

ZL 2006 2 0122522.X (China)  
Nr. 20 2006 012 052.1(Germany)  
M308308 (Taiwan)  
GB 06 1 6099.8 (Great Britain)  
06 07229 (France)

### Warranty

The product is warranted against defects in material and workmanship while used in normal service for a period of 5 year from the date of sale to the original customer. The GEM policy is one of continual development and improvement; therefore GEM reserves the right to change specifications without notice.

GIANNI INDUSTRIES, INC.

No. 13, Zhong Sing Road, Tu-Cheng Industrial Zone,  
Tu-Cheng City, Taipei, Taiwan 23678  
Tel: 886-2 2267 7986 / Fax: 886-2 2267 9876  
E-Mail: info@gianni.com.tw  
Website: gianni.tw  
Copyright 2008 Gianni industries, inc. All rights reserved.  
DM-CA-EM-NH350 Ver. D Published on 2008.08.18



The products are manufactured under an ISO 9001 & QC 080000 Certified Quality Management Program environment back its product quality, performance and commitment to customer satisfaction.

## Free Manuals Download Website

<http://myh66.com>

<http://usermanuals.us>

<http://www.somanuals.com>

<http://www.4manuals.cc>

<http://www.manual-lib.com>

<http://www.404manual.com>

<http://www.luxmanual.com>

<http://aubethermostatmanual.com>

Golf course search by state

<http://golfingnear.com>

Email search by domain

<http://emailbydomain.com>

Auto manuals search

<http://auto.somanuals.com>

TV manuals search

<http://tv.somanuals.com>