



Specifications

- Voltage Tolerance: 10%
- Current Draw: 420mA@12 VDC; 210mA@24 VDC (at temperature 20 C)
- Magnetic bond sensor monitor output (GS-300M) (SPDT rated 3A@30VDC), indicates the door locked or unlocked status.
- Operating Temperature: -30~+55 C
- Humidity: 0~95% non-condensing.
- Lock's surface Temperature (when the power is on): <current temperature +20 C
- Holding Force: Up to 1200 lbs (545 Kg) in shear.
- The Gap between the Lock and Armature plate is 2 mm
- Special Finishes for magnet and armature plate: Zinc
- Epoxy Potting Compound: E87252 (S), UL94V-0
- Weight)Approx.(: 1.4 Kg

Statement

The GS-300 mini surface mount shear lock with complete housing is specially designed for surface mounting door. The housing holds the magnet should be fitted above the door and the housing holds the Armature Plate should be installed on the door. It is essential to leave a minimum gap of 2mm between the Shear Lock and the Armature Plate, in order to perform the correct operation.

Dimension

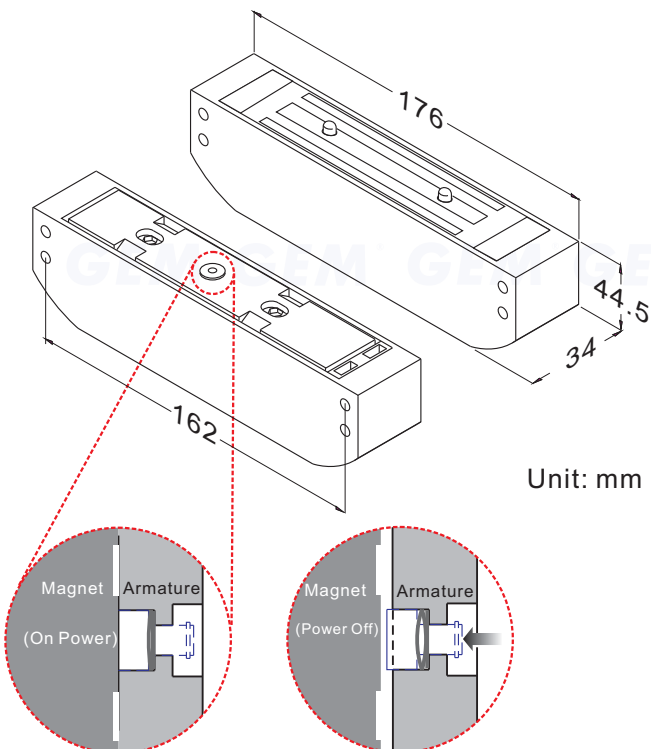

Unit: mm

Unique Anti-Residual design

When there is no power, there will be no holding force, and the push-off button will pop out immediately, to release the Electromagnetic Lock and the Armature Plate for no residual magnetism.

Surface Installation

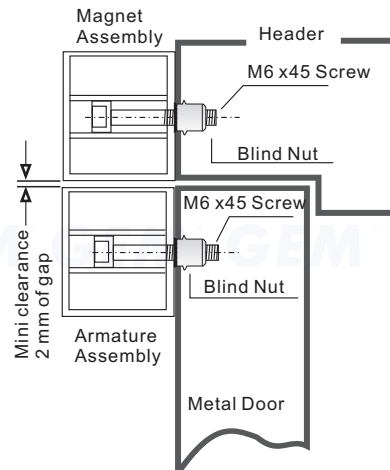
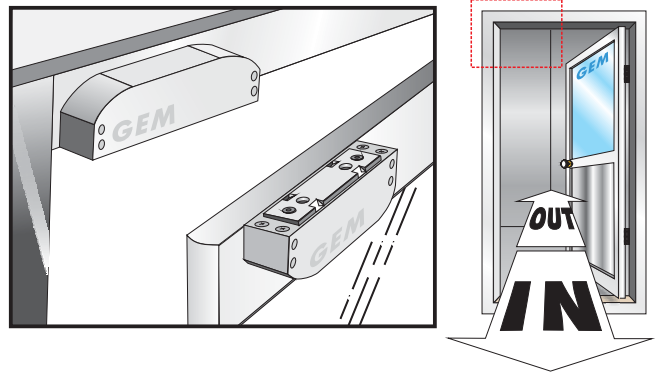

Warranty

The product is warranted against defects in material and workmanship while used in normal service for a period of 5 year from the date of sale to the original customer. The GEM policy is one of continual development and improvement; therefore GEM reserves the right to change specifications without notice.

GIANNI INDUSTRIES, INC.

No. 13, Zhong Sing Road, Tu-Cheng Industrial Zone,
Tu-Cheng City, Taipei, Taiwan 23678
Tel: 886-2 2267 7986 / Fax: 886-2 2267 9876
E-Mail: info@gianni.com.tw
Website: gianni.tw
Copyright 2008 Gianni industries, inc. All rights reserved.
DM-CA-GS-300 Ver. C Published on 2008.05.14



The products are manufactured under an ISO 9001 & QC 080000 Certified Quality Management Program environment back its product quality, performance and commitment to customer satisfaction.

Free Manuals Download Website

<http://myh66.com>

<http://usermanuals.us>

<http://www.somanuals.com>

<http://www.4manuals.cc>

<http://www.manual-lib.com>

<http://www.404manual.com>

<http://www.luxmanual.com>

<http://aubethermostatmanual.com>

Golf course search by state

<http://golfingnear.com>

Email search by domain

<http://emailbydomain.com>

Auto manuals search

<http://auto.somanuals.com>

TV manuals search

<http://tv.somanuals.com>