

Models P420A-3100 & P420A-5100

Triplex Ceramic
Plunger Pump
Operating Instructions/
Repair and Service
Manual

Corrossion Resistant Pumps

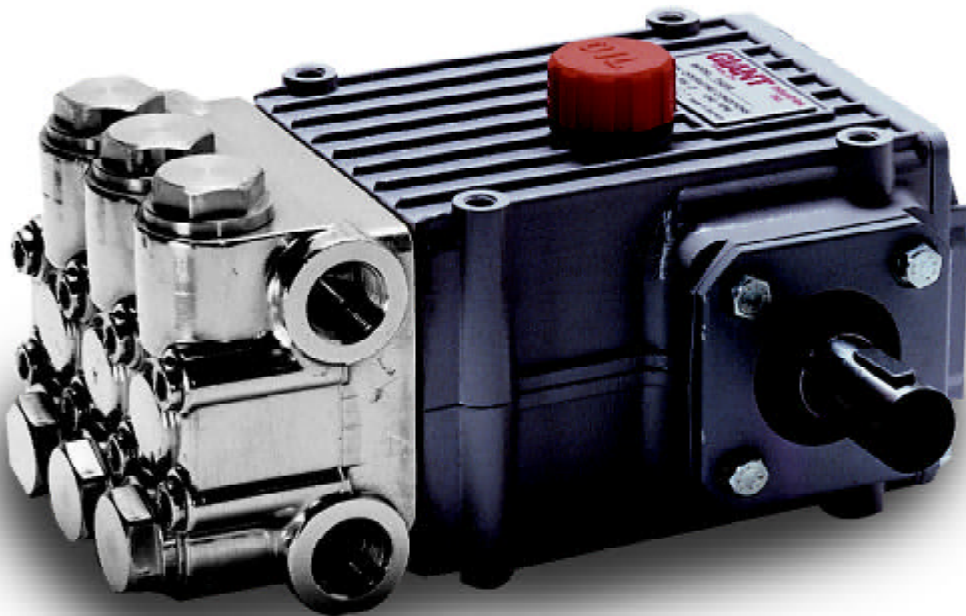

Contents:

Installation Instructions:	page 2
Specifications:	page 3
Parts List/Torque Specs:	page 4
Recommended Spare Parts List	page 4
Exploded View/Kits:	page 5
Repair Instructions:	pages 6-7
Pump mounting selection Guide:	page 7
Dimensions:	back page
Warranty Information	back page

INSTALLATION INSTRUCTIONS

Installation of the Giant Industries, Inc., pump is not a complicated procedure, but there are some basic steps common to all pumps. The following information is to be considered as a general outline for installation. If you have unique requirements, please contact Giant Industries, Inc. or your local distributor for assistance.

1. The pump should be installed flat on a base to a maximum of a 15 degree angle of inclination to ensure optimum lubrication.
2. The inlet to the pump should be sized for the flow rate of the pump with no unnecessary restrictions that can cause cavitation. Teflon tape should be used to seal all joints. If pumps are to be operated at temperatures in excess of 160° F, it is important to insure a positive head to the pump to prevent cavitation.
3. The discharge plumbing from the pump should be properly sized to the flow rate to prevent line pressure loss to the work area. It is essential to provide a safety bypass valve between the pump and the work area to protect the pump from pressure spikes in the event of a blockage or the use of a shut-off gun.

4. Use of a dampener is necessary to minimize pulsation at drive elements, plumbing, connections, and other system areas. The use of a dampener with Giant Industries, Inc. pumps is optional, although recommended by Giant Industries, Inc. to further reduce system pulsation. Dampeners can also reduce the severity of pressure spikes that occur in systems using a shut-off gun. A dampener must be positioned downstream from the unloader.

5. Crankshaft rotation on Giant Industries, Inc. pumps should be made in the direction designated by the arrows on the pump crankcase. Reverse rotation may be safely achieved by following a few guidelines available upon request from Giant Industries, Inc. Required horsepower for system operation can be obtained from the chart on page 3.

6. Before beginning operation of your pumping system, remember: Check that the crankcase and seal areas have been properly lubricated per recommended schedules. Do not run the pump dry for extended periods of time. Cavitation will result in severe damage. Always remember to check that all plumbing valves are open and that pumped media can flow freely to the inlet of the pump.

Finally, remember that high pressure operation in a pump system has many advantages. But, if it is used carelessly and without regard to its potential hazard, it can cause serious injury.

IMPORTANT OPERATING CONDITIONS

Failure to comply with any of these conditions invalidates the warranty.

1. Prior to initial operation, add oil to the crankcase so that oil level is between the two lines on the oil dipstick. **DO NOT OVERFILL.**

Use Recommended Giant Oil

Crankcase oil should be changed after the first 50 hours of operation, then at regular intervals of 500 hours or less depending on operating conditions.

2. Pump operation must not exceed rated pressure, volume, or RPM. A pressure relief device must be installed in the discharge of the system.

3. Acids, alkalines, or abrasive fluids cannot be pumped unless approval in writing is obtained before operation from Giant Industries, Inc.

4. Run the pump dry approximately 10 seconds to drain the water before exposure to freezing temperatures.

NOTE: Contact Giant Industries for Service School Information. Phone: (419)-531-4600

Specifications

Model P420A-3100/5100

Volume	Up to 13.0 GPM (49 lm)
Discharge Pressure	Up to 2000 PSI (138 bar)
.....	(at 11 GPM)
Inlet Pressure	Up to 140 PSI (9.7 bar)
Stroke	24mm
RPM	Up to 1460 RPM
Plunger Diameter	25mm
Temperature of Pumped Fluids	Up to 160 °F (71 °C)
Inlet Ports	(2) 3/4" BSPP (P420A-5100)
Inlet Ports	(2) 3/4" NPT (P420A-3100)
Discharge Ports	(2) 3/4" BSPP (P420A-5100)
Discharge Ports	(2) 3/4" NPT (P420A-3100)
Shaft Rotation	Top of pulley towards fluid end
Crankshaft Diameter	28mm
Key Width	8mm
Shaft Mounting	Either side ¹
Weight	36lbs. 11oz. (0.52 kg)
Crankcase Capacity	30fl.oz. (0.89 liters)
Volumetric Efficiency @ 1460	0.95
Mechanical Efficiency @ 1460	0.86

Consult the factory for special requirements that must be met if the pump is to operate beyond one or more of the limits specified above.

PULLEY INFORMATION

Pulley selection and pump speed are based on a 1725 RPM motor and "B" section belts. When selecting desired GPM, allow for a ±5% tolerance on pumps output due to variations in pulleys, belts and motors among manufacturers.

1. Select GPM required, then select appropriate motor and pump pulley from the same line.
2. The desired pressure is achieved by selecting the correct nozzle size that corresponds with the pump GPM.

HORSEPOWER INFORMATION

Horsepower ratings shown are the power requirements for the pump. Gas engine power outputs must be approximately twice the pump power requirements shown above.

We recommend that a 1.1 service factor be specified when selecting an electric motor as the power source. To compute specific pump horsepower requirements, use the following formula:

$$\frac{\text{GPM} \times \text{PSI}}{1450} = \text{hp}$$

P420A-3100/5100 PULLEY SELECTION & HORSEPOWER REQUIREMENTS							
PUMP PULLEY	MOTOR PULLEY	RPM	GPM	1000 PSI	1500 PSI	1700 PSI	2000 PSI
7.75	4.50	785	7.0	4.8	7.2	8.2	9.6
7.75	5.00	900	8.0	5.5	8.3	9.4	11.0
7.75	5.75	1010	9.0	6.2	9.3	10.5	12.4
7.75	6.00	1120	9.9	6.9	10.3	11.7	13.7
7.75	6.75	1240	11.0	7.6	11.4	12.9	15.2
7.75	7.75	1460	13.0	8.9	13.4	15.2	

P420A-3100/5100 PUMP PARTS LIST

<u>ITEM</u>	<u>PART</u>	<u>DESCRIPTION</u>	<u>QTY.</u>	<u>ITEM</u>	<u>PART</u>	<u>DESCRIPTION</u>	<u>QTY.</u>
1	08377	Crankcase	1	16G	07161-0100	Copper Washer	3
2	08378	Oil Fill Plug with Gasket	1	17	07314	Crosshead Pin	3
3	06479	Crankcase cover	1	19	08366	Oil Seal	3
3A	07186	Oil Sight Glass w/ Gasket	1	20	08098	Seal Case	3
4	08380	O-Ring	1	21	06613	O-Ring (P420-3100)	3
5	12137	Oil Drain Plug	1	21	07266	O-Ring (P420-5100)	3
5A	07182	Gasket for Oil Drain Plug	1	22	08059	O-Ring	3
5B	08092	Plug with Gasket	1	23	12254	V-Sleeve	3
6	08093	Screw	4	23A	08099	Spacer Ring	3
6A	08094	Spring Washer	12	23B	12255	Weep Seal	3
7	08471	Bearing Cover, Open	1	24	08376	Pressure Ring	6
8	08472	Bearing Cover, Closed	1	25	06373	Weep Return Ring	3
8A	06245	Shim	1	26	06614	Manifold (P420-3100)	1
9	01016	O-Ring	2	26	06374	Manifold (P420-5100)	1
10	08095	Screw with Washer	8	27A	06615	Valve Assembly (P420A-3100)	6
11	07459	Radial Shaft Seal	1	27A	06375	Valve Assembly (P420A-5100)	6
12	08473	Bearing	1	27	06376	Valve Seat	6
12A	08474	Bearing	1	28	08371	Valve Plate	6
13	08475	Crankshaft	1	29	06377	Valve Spring	6
14	08091	Fitting Key	1	30	08372	Valve Spring Retainer	6
15	08390	Connecting Rod Assembly	3	31	07212-0001	O-Ring, Viton (P420A-3100)	6
15A	07311	Screw with Washer	6	31	07212	O-Ring (P420A-5100)	6
16	06611	Plunger Assy. Items 16A-16G	3	32	06616	Plug (P420A-3100)	6
16A	08096	Plunger Base	3	32	06379	Plug (P420A-5100)	6
16B	08398	Plunger Pipe	3	33	07214-0001	O-Ring, Viton (P420A-3100)	6
16C	07256	Centering Sleeve	3	33	07214	O-Ring (P420-5100)	6
16D	08097	Tensioning Screwing	3	34	06612	Inner Hexagon Screw	8
16E	07023	O-Ring	3	36	13150	Plug, G 3/4" (P420-5100)	1
16F	07203	Backup Ring	3	37	13321-0100	Plug, G 1" (P420-5100)	1

P420A-3100/5100 PUMP TORQUE SPECIFICATIONS

<u>Position</u>	<u>Item#</u>	<u>Description</u>	<u>Torque Amount</u>
15A	07311	Screw with Washer	216 in.-lbs.
16D	08097	Tensioning Screw	240 in.-lbs.
32	06616/06379	Plug (P420A-3100/P420A-5100)	125 ft.-lbs.
34	06612	Inner Hexagon Screw	35 ft.-lbs.

Preventative Maintenance Check-List & Recommended Spare Parts List

<u>Check</u>	<u>Daily</u>	<u>Weekly</u>	<u>50hrs</u>	<u>Every 500 hrs</u>	<u>Every 1500 hrs</u>	<u>Every 3000 hrs</u>
Oil Level/Quality	X					
Oil Leaks	X					
Water Leaks	X					
Belts, Pulley		X				
Plumbing		X				
<u>Recommended Spare Parts</u>						
Oil Change			X	X		
Seal Spare Parts (1 kit/pump) (See page 5 for kit list)					X	
Oil Seal Kit (1 kit/pump) (See page 5 for kit list)					X	
Valve Spare Parts (1 kit/pump) (See page 5 for kit list)						X

EXPLODED VIEW - P420A-3100/5100 PUMPS

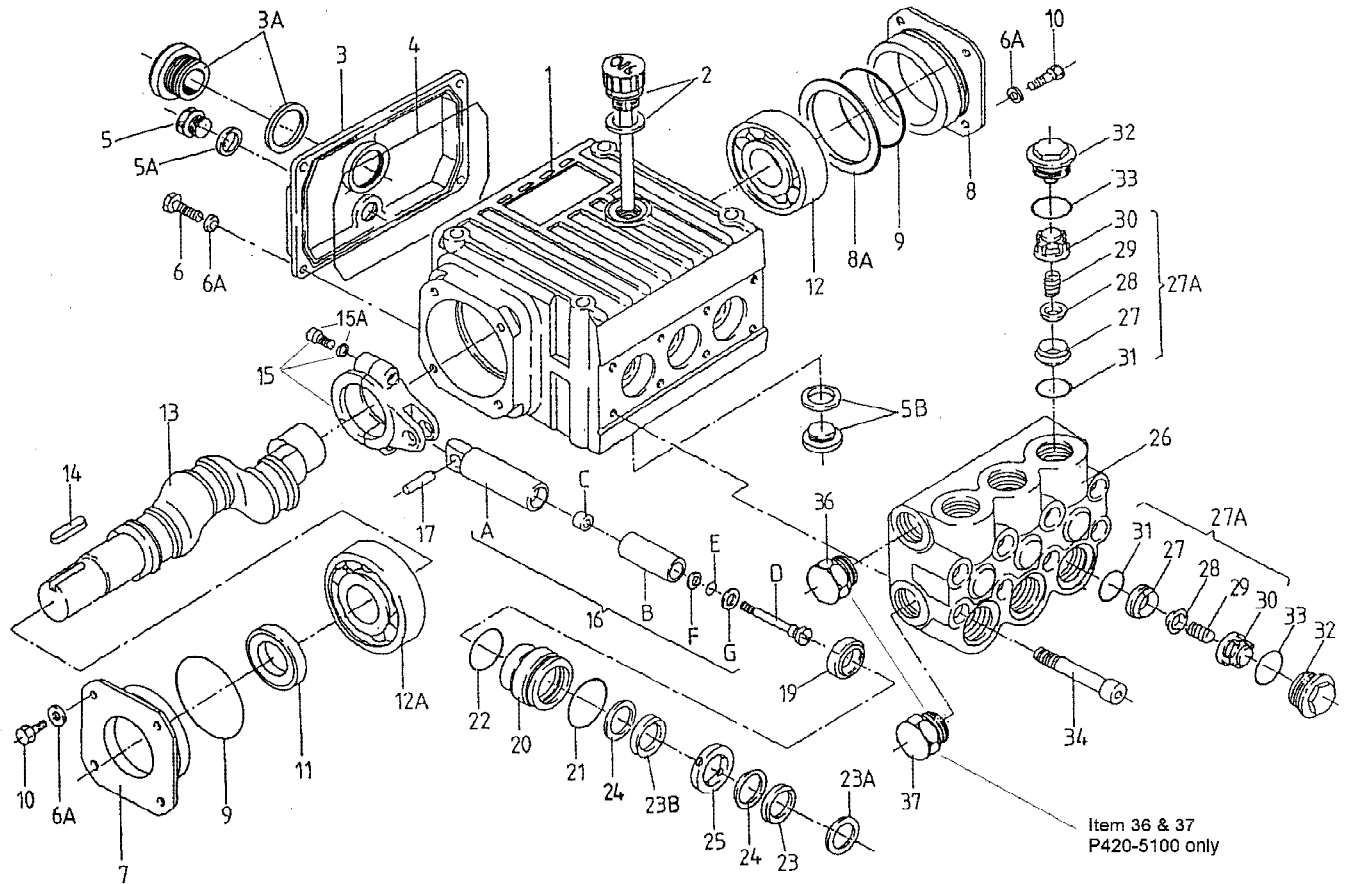

P420A-3100/5100 PUMP REPAIR KITS

Plunger Packing Kits

09542 (P420-3100)

Item	Part #	Description	Qty.
21	06613	O-Ring	3
22	08059	O-Ring	3
23	12254	V-Sleeve	3
23B	12255	Weep Seal	3
24	08376	Pressure Ring	6

Plunger Packing Kits

09140 (P420-5100)

Item	Part #	Description	Qty.
21	07266	O-Ring	3
22	08059	O-Ring	3
23	12254	V-Sleeve	3
23B	12255	Weep Seal	3
24	08376	Pressure Ring	6

Oil Seal Kit

09306

Item	Part #	Description	Qty.
19	08366	Oil Seal	3

Valve Assembly Kit (P420A-3100)

09522

Item	Part #	Description	Qty.
27A	06615	Valve Assembly, Complete	6
33	07214-0001	O-Ring, Viton	6

Valve Assembly Kit (P420A-5100)

09478

Item	Part #	Description	Qty.
27A	06375	Valve Assembly, Complete	6
33	07214	O-Ring	6

REPAIR INSTRUCTIONS - P420A-3100/5100 PUMPS

Note: Always take time to lubricate all metal and nonmetal parts with a light film of oil before reassembly. This step will ensure proper fit, at the same time protecting the pump nonmetal parts (i.e., the elastomers) from cutting and scoring.

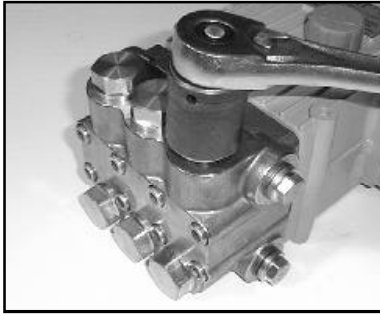

- 1) With a socket wrench, remove the three discharge valve plugs and three inlet valve plugs (32). Inspect the o-ring (33) for wear and replace if damaged.

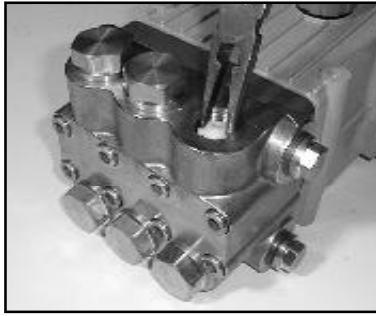

- 2) Using needle nose pliers, remove the inlet and discharge valve assemblies (27A). Note: It may become necessary to remove the valve seat (27) from the valve casing using a slidehammer.



- 3) By inserting a small screw driver between the valve seat (27) and the valve spring retainer (30), the valve assembly can be separated.



- 4) Remove the o-ring (31). Inspect all parts for wear and replace as necessary. Apply one drop of loctite 243 to the valve plugs (32) and tighten to 125 ft. lbs.

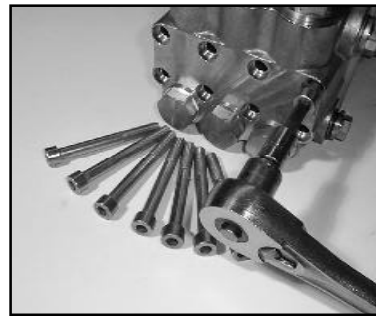

- 5) Use a 8mm allen wrench to remove the 8 socket head cap screws (34). Carefully slide the valve casing (26) out over the plungers. Remove the weep return rings (25).



- 6) Remove each seal case (20) with o-rings and oil seals (21 and 22) from the crankcase (1).

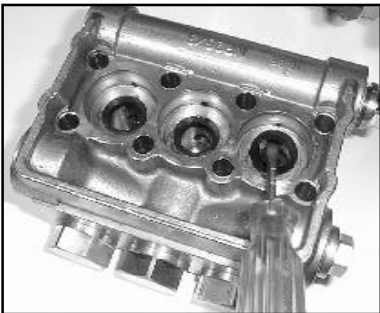

- 7) Remove the pressure rings (24), and v-sleeves (23) and spacer ring (23A) from the valve casing (26). Remove the remaining v-sleeves (23B) and pressure rings (24) from the seal case (20).

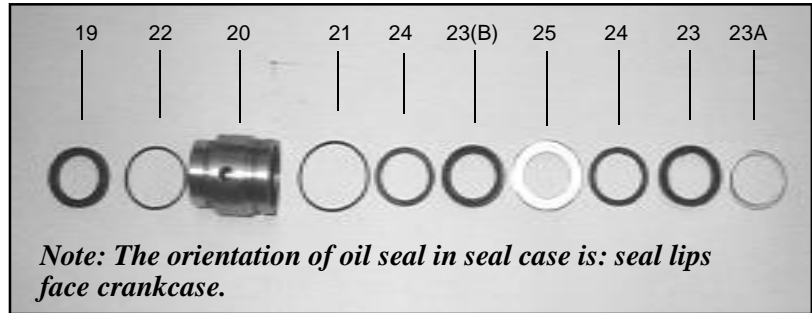

- 8) Inspect all parts for wear and replace as needed.

REASSEMBLY INSTRUCTIONS - P420A-3100/5100 PUMPS

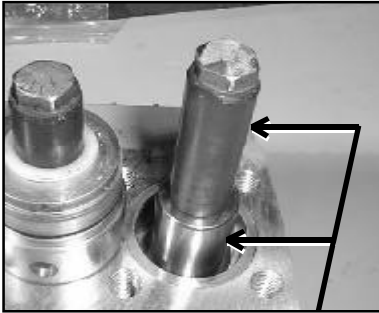

9) Check surfaces of plunger pipe (16B).



10) Place each seal case (20) with new o-rings (21 and 22) and new oil seals (19) over plungers (16) with weep hole down. Generously lubricate o-rings and oil seals before reassembly.



11) Place pressure rings and weep seals (23B) over plungers and into each seal case (20).



12) Place weep return rings (25) over the plunger (16) and pressure ring over plunger (24).

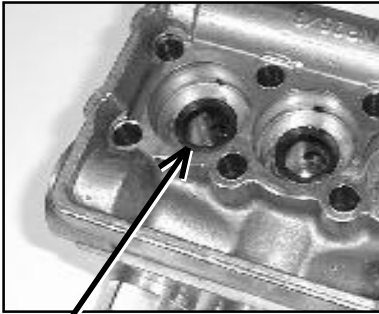

13) Generously lubricate v-sleeves. Assemble spacer rings (23A), and v-sleeves (23) into valve casing (26).

14) Slide valve casing over plungers and seat firmly. Replace the 8 socket head cap screws (34) and tighten to 35 ft.-lbs. in a crossing pattern (as shown below).

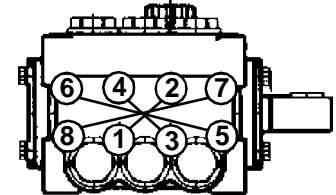

Pump Mounting Selection Guide

Bushings

07175 - 28 mm Tapered H Bushing

Pulley & Sheaves

01055 - 7.75" Cast Iron 2 gr. - AB Section

01062 - 7.75" Cast Iron - 2 gr. - AB Section

Rails

07358 - Plated Steel Channel Rails
(L=9.18" x w=1.88" x h=3.00")

Contact Giant Industries for service school information. Phone: (419) 531-4600

P420A-3100/5100 PUMP DIMENSIONS - INCHES (MM)

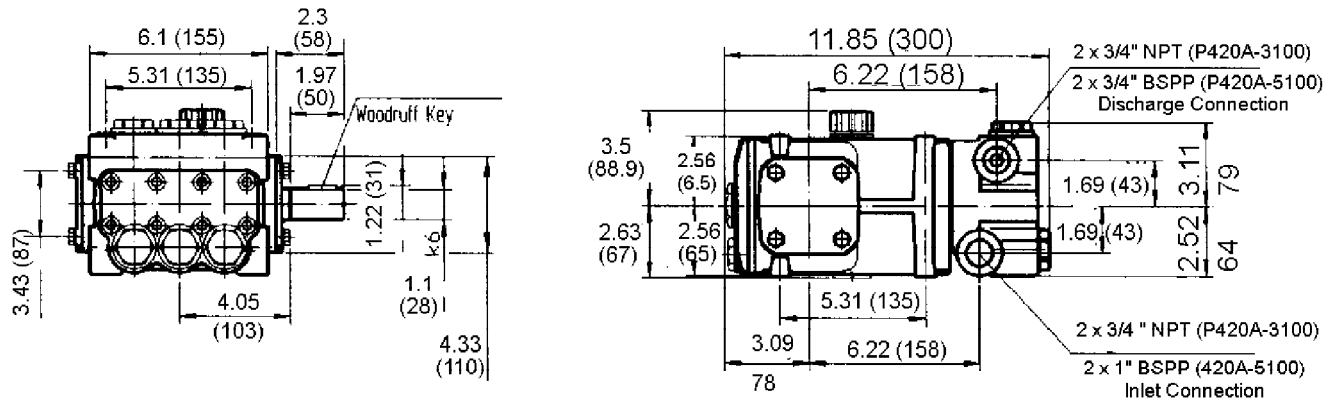

GIANT INDUSTRIES LIMITED WARRANTY

Giant Industries, Inc. pumps and accessories are warranted by the manufacturer to be free from defects in workmanship and material as follows:

1. For portable pressure washers and self-service car wash applications, the discharge manifolds will never fail, period. If they ever fail, we will replace them free of charge. Our other pump parts, used in portable pressure washers and in car wash applications, are warranted for five years from the date of shipment for all pumps used in NON-SALINE, clean water applications.
2. One (1) year from the date of shipment for all other Giant industrial and consumer pumps.
3. Six (6) months from the date of shipment for all rebuilt pumps.
4. Ninety (90) days from the date of shipment for all Giant accessories.

This warranty is limited to repair or replacement of pumps and accessories of which the manufacturer's evaluation shows were defective at the time of shipment by the manufacturer. The following items are NOT covered or will void the warranty:

1. Defects caused by negligence or fault of the buyer or third party.
2. Normal wear and tear to standard wear parts.
3. Use of repair parts other than those manufactured or authorized by Giant.
4. Improper use of the product as a component part.
5. Changes or modifications made by the customer or third party.
6. The operation of pumps and or accessories exceeding the specifications set forth in the Operations Manuals provided by Giant Industries, Inc.

Liability under this warranty is on all non-wear parts and limited to the replacement or repair of those products returned freight prepaid to Giant Industries which are deemed to be defective due to workmanship or failure of material. A Returned Goods Authorization (R.G.A.) number and completed warranty evaluation form is required prior to the return to Giant Industries of all products under warranty consideration. Call (419)-531-4600 or fax (419)-531-6836 to obtain an R.G.A. number.

Repair or replacement of defective products as provided is the sole and exclusive remedy provided hereunder and the MANUFACTURER SHALL NOT BE LIABLE FOR FURTHER LOSS, DAMAGES, OR EXPENSES, INCLUDING INCIDENTAL AND CONSEQUENTIAL DAMAGES DIRECTLY OR INDIRECTLY ARISING FROM THE SALE OR USE OF THIS PRODUCT.

THE LIMITED WARRANTY SET FORTH HEREIN IS IN LIEU OF ALL OTHER WARRANTIES OR REPRESENTATION, EXPRESS OR IMPLIED, INCLUDING WITHOUT LIMITATION ANY WARRANTIES OR MERCHANTABILITY OR FITNESS FOR A PARTICULAR PURPOSE AND ALL SUCH WARRANTIES ARE HEREBY DISCLAIMED AND EXCLUDED BY THE MANUFACTURER.



GIANT INDUSTRIES, INC., 900 N. Westwood Ave., P.O. Box 3187, Toledo, Ohio 43607
 PHONE (419) 531-4600, FAX (419) 531-6836, www.giantpumps.com
 © Copyright 2002 Giant Industries, Inc.

10/02P420A-3100/5100.PM6

Free Manuals Download Website

<http://myh66.com>

<http://usermanuals.us>

<http://www.somanuals.com>

<http://www.4manuals.cc>

<http://www.manual-lib.com>

<http://www.404manual.com>

<http://www.luxmanual.com>

<http://aubethermostatmanual.com>

Golf course search by state

<http://golfingnear.com>

Email search by domain

<http://emailbydomain.com>

Auto manuals search

<http://auto.somanuals.com>

TV manuals search

<http://tv.somanuals.com>