

GILSON MIXERS

CONCRETE MIXER MODEL 600CM

OPERATING INSTRUCTIONS & PARTS LIST

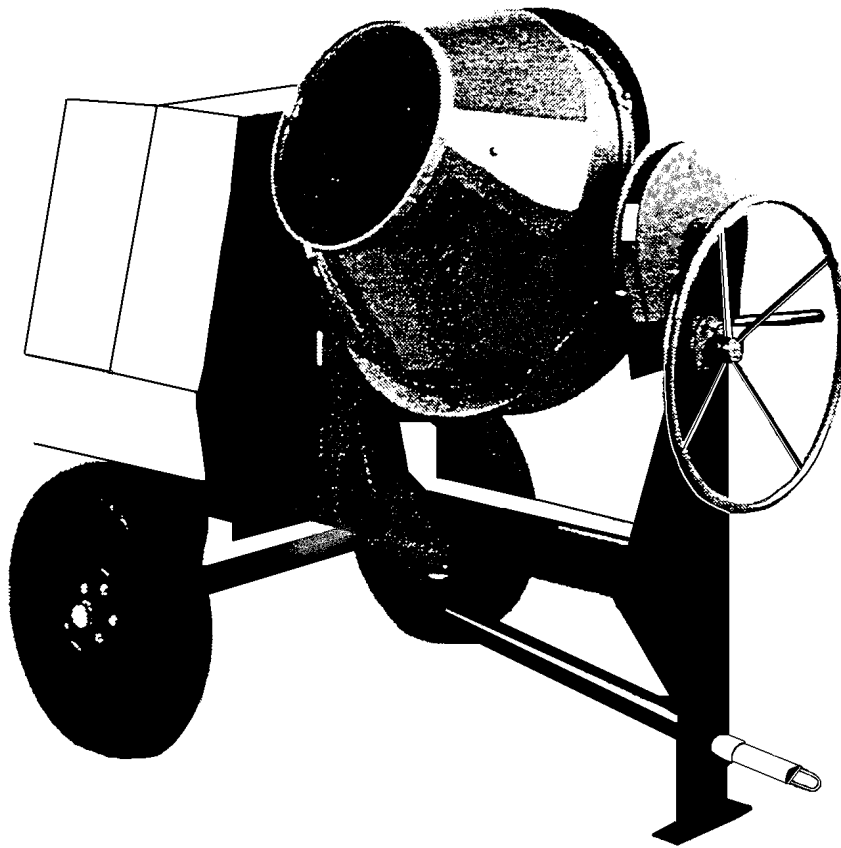

**GILSON MIXERS
BY**



4343 Easton Road · St. Joseph, MO 64503

816-233-4840 · 800-253-3676

Fax 816-233-4624 · 888-253-3676

E-Mail: cleform@ccp.com

Web Address: www.cleform.com

TO THE OWNER:

This owner's manual provides the information needed to operate and maintain this Gilson mixer. Carefully read and follow all safety and operating instructions in this manual. Also, be sure every operator of this mixer reads this manual before operating the mixer. The replacement of any part on this mixer by other than the manufacturer's authorized replacement part may adversely affect the performance, durability or safety of the product.

Be sure safety precautions are observed. Read and follow all safety and operating instructions in this operator's manual.

The manufacturer reserves the right to make changes on, or add improvements to its product at any time without prior notice or obligation. The manufacturer reserves the right to decide, upon its sole discretion and at any time, to discontinue a product.

Information regarding operation and maintenance of the engine can be found in a separate engine manual supplied with this mixer if the mixer is supplied with an engine. The engine manual provides all the information required regarding engine adjustments, operation and maintenance. Should any questions arise concerning engine operation or service, contact the nearest engine repair facility or the engine manufacturer.

NOTICE: Record the model and serial numbers of the mixer (located on the nameplate) in the spaces provided. Engine model, type and code numbers are located on the blower housing, cylinder head or backplate.

Product Model Number: _____

Product Serial Number: _____

Engine/Motor Model Number: _____

Engine/Motor Code Number: _____

Purchase Date: _____

Dealer Purchased From: _____

Dealer Address: _____

Dealer Phone Number: _____

Table of Contents

1. Warranty Information	3
2. Safety Instructions, Pre-operational Checks	4-5
3. Lubrication	5-6
4. Care of Mixer	6
5. Batch/Mix Instructions	6
6. Parts Explosions and Lists	7

HOW TO OBTAIN PARTS AND SERVICE INFORMATION

For parts and service information, contact either your local dealer or the Cleform Tool Corp. factory:

CLEFORM TOOL CORP.
4343 EASTON ROAD
ST. JOSEPH, MO 64503
800-253-3676 PHONE
888-253-3676 FAX

HOW TO ORDER PARTS

When ordering parts be sure to indicate the following information:

- **Name of each part**
- **Complete part number**
- **Quantity of each part**
- **Model Name** (Include all letters and numbers)
- **Serial Number** (Include all letters and numbers)

WARRANTY:

This mixer is warranted to the original purchaser only, to be free of defects in material and workmanship under normal use, for one year from purchase date. Cleform Tool Corp. shall without charge, repair or replace parts which are found to be defective. All transportation charges for replacement parts must be borne by the purchaser.

For Warranty service, the product must be delivered, with proof of purchase date, to the dealer of original purchase, or any factory authorized service dealer. The delivery of the unit must be made not later than 30 days after the expiration of the warranty period.

EXCLUSIONS FROM WARRANTY:

1. The following items are not covered under the GILSON MIXER One Year Limited Warranty and are warranted by the respective manufacturer:
 - A. Engines, including starters, generators, alternators and gear reducers.
 - B. Enclosed gear transmissions.
 - C. Hydraulic components, including pumps, motors and valves
 - D. A copy of the warranty and service contact information for the above items are furnished with the individual product.
2. All consequential damages, including pickup and delivery of the unit, communication, mileage charges and/or rental of a replacement unit during repairs, are not covered under this warranty, nor is any loss of income and/or other loss resulting from the failure of the product to function due to a warranty defect.
3. This warranty will not apply when the product becomes inoperative due to misuse, normal wear, neglect, improper maintenance, accident, or freight damage; has not been operated and maintained in accordance with the instructions furnished in the Operator's Manual; or has been altered or modified without approval from the factory Service Department.
4. No parts or products are to be returned to the factory without prior written approval from the factory.

All implied warranties, including those of merchantability and fitness for a particular purpose, are limited to one year from date of purchase by the original retail customer and to the extent permitted by law any and all implied warranties are excluded and disclaimed after the expiration of such period.

Some states do not allow limitations on how long an implied warranty lasts, or the exclusion of limitations of incidental or consequential damages, so the above limitations and exclusions may not apply to you.

This warranty gives you specific legal rights, and you may also have other rights, which vary from state to state.

SAFETY INSTRUCTIONS

SAFETY PRECAUTIONS:



This is the industry's safety alert symbol. This symbol calls attention to items or operations that could be dangerous. This symbol can be found throughout this manual and on safety decals on the mixer. Read these messages carefully.

The following precautions are suggested to help prevent accidents. Read and practice the following precautions before operating this equipment. Equipment should be operated only by those who are responsible and have been properly instructed.

1. Read all operating and maintenance instructions before operating or servicing mixer. **Test run empty prior to actual use.**
2. A mixer is only as safe as its operator. Give complete and undivided attention to the operation of the mixer.
3. Know how to stop the mixer and the engine instantly.
4. Always have all guards and safety devices attached and in place before operating mixer. Close engine housing during operation.
5. Keep inexperienced and unauthorized people away from the mixer at all times.
6. Never leave the mixer unattended while it is running.
7. Shut off engine or disconnect the electric motor before making any adjustments or putting hands or tools in the drum.



NEVER REACH INTO THE DRUM OR PLACE TOOLS INTO THE DRUM WHILE THE MIXER IS RUNNING.

8. Do not overfill the drum. Do not exceed the mixer's rated capacity.
9. Do not smoke while refueling the engine. Shut off the engine and allow it to cool before refueling. Do not spill fuel.
10. Block mixer wheels when mixing.
11. Use safety chains while towing mixer.
12. Keep the mixer in good operating condition. Loose or damaged parts are dangerous.
13. Avoid loose clothing that could get caught in moving parts or on control levers.



KEEP HANDS AND FEET AWAY FROM MOVING PARTS.

14. Do not add material to the drum while stopped. Start the drum before adding material.
15. Keep all warning, caution and safety instruction labels in good condition. Replace missing, damaged or illegible labels.

TOWING & SAFETY CHAINS:

For transporting the mixer, slide the tow pole out as far as possible and insert the locking pin. When operating the mixer, slide the tow pole in and lock it in place.

Make sure drum is locked in position and engine housing is closed and secured.

Cross the safety chains under the tow pole and fasten them to the tow vehicle. (fig.1)

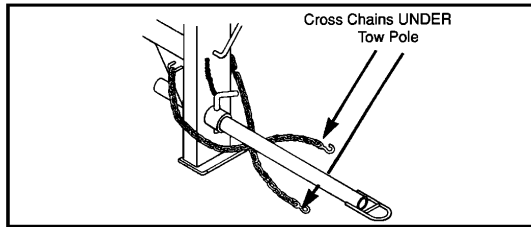

FIGURE 1

NOTE! Safety chain length may need to be altered for proper connection to tow vehicle. Reposition the hooks, DO NOT cut chain.

Allow enough slack to permit proper vehicle turning while keeping chains snug enough to prevent tow pole from contacting the ground in case the hitch uncouples.

PRIOR TO START UP:

1. Examine the mixer carefully to make sure there was no damage during shipment or since the last use. Report any damage immediately to the transportation company. Repair any damage before using the mixer.
2. Check for free rotation of the mixer drum yoke by rotating the drum through one complete dump-charge-dump cycle. Make sure no foreign objects or tools are in the drum before starting the motor.
3. Check the engine oil. Fill as required. Refer to the engine manual for oil specifications.
4. Fill the fuel tank with fresh, clean fuel. Refer to the engine manual for fuel specifications.
5. Grease all fittings as called out in the lubrication specifications.
6. Start the motor and check for smooth operation of the drum, ring gear, and pinion.

Note: After initial 10 hours of operations, check chain/belts for proper tension and sprockets/pulleys for alignment. Check these items monthly to prevent premature wear/failure.

LUBRICATION

Use lithium based grade 2 multi-purpose grease.

Drum Shaft Tube:

Drum shaft lubrication can be performed by removing the 1/8" pipe plug (item 4, fig3) and installing the appropriate grease fitting. Greasing should be done yearly.

Yoke Bearing Hangers:

Yoke bearing hangers are located on the yoke ends and are equipped with grease fittings. These bearings should be greased weekly.

Wheel Bearings:

Grease wheel bearings once per year. Thoroughly remove old grease from bearings and spindle before repacking. Pack bearings 1/2 to 2/3 full to prevent overheating.

Drum Tilt Brake Bearing:

The brake bearing casting is located near the front of the mixer and should be greased weekly.

Handwheel Bearing:

The handwheel hub bearing is located on the front of the mixer, behind the handwheel. This bearing should be greased weekly.

WARNING: DO NOT GREASE BRAKE BAND OR OUTER BRAKING SURFACE OF TILT GEAR.

Jack Shaft Bearings:

Pillow block style bearings are used on the drive train counter shaft. These bearings should be greased weekly.

Drive Chain:

The drive chain should be lubricated monthly with SAE #20 or SAE #30 oil. Apply the oil between the side plates.

Engine/Motor:

Refer to the manufacturer's engine or motor operating instructions for all maintenance and lubrication requirements and instructions.

LUBRICATION FREQUENCY CHART:

#	ITEM	FREQUENCY	FIGURE	CODE	PLACES
1	Yoke Bearing Casting	weekly	3	grease	2
2	Handwheel Hub	weekly	4	grease	1
3	Drum Tilt Brake Bearing Casting	weekly	4	grease	1
4	Drive Shaft & Jackshaft	weekly	4	grease	1
5	Drum Shaft Tube	yearly	3	grease	1
6	Wheel Bearings	yearly	1	grease	2
7	Drive Chain	monthly	4	oil	1

MIXING INSTRUCTIONS:

1. Start the drum rotating.
2. Add water.
3. Add cement and one shovelful of coarse aggregate. The coarse aggregate will break up any lumps in the cement.
4. Add remaining aggregate: crushed stone, pit-run gravel or sand.
5. Mix batch for approximately one minute. Drum speed should be about 25 r.p.m.

CARE OF MIXER:

It is important to keep the inside of the mixing drum free of hardened concrete. After discharging the last batch of concrete each day, add a pailful of water and two shovelfuls of gravel to the drum. This will scour the inside of the drum. Mix for about two minutes, discharge and rinse the drum with water.

ENGINE HOUSE, WHEEL & AXLE

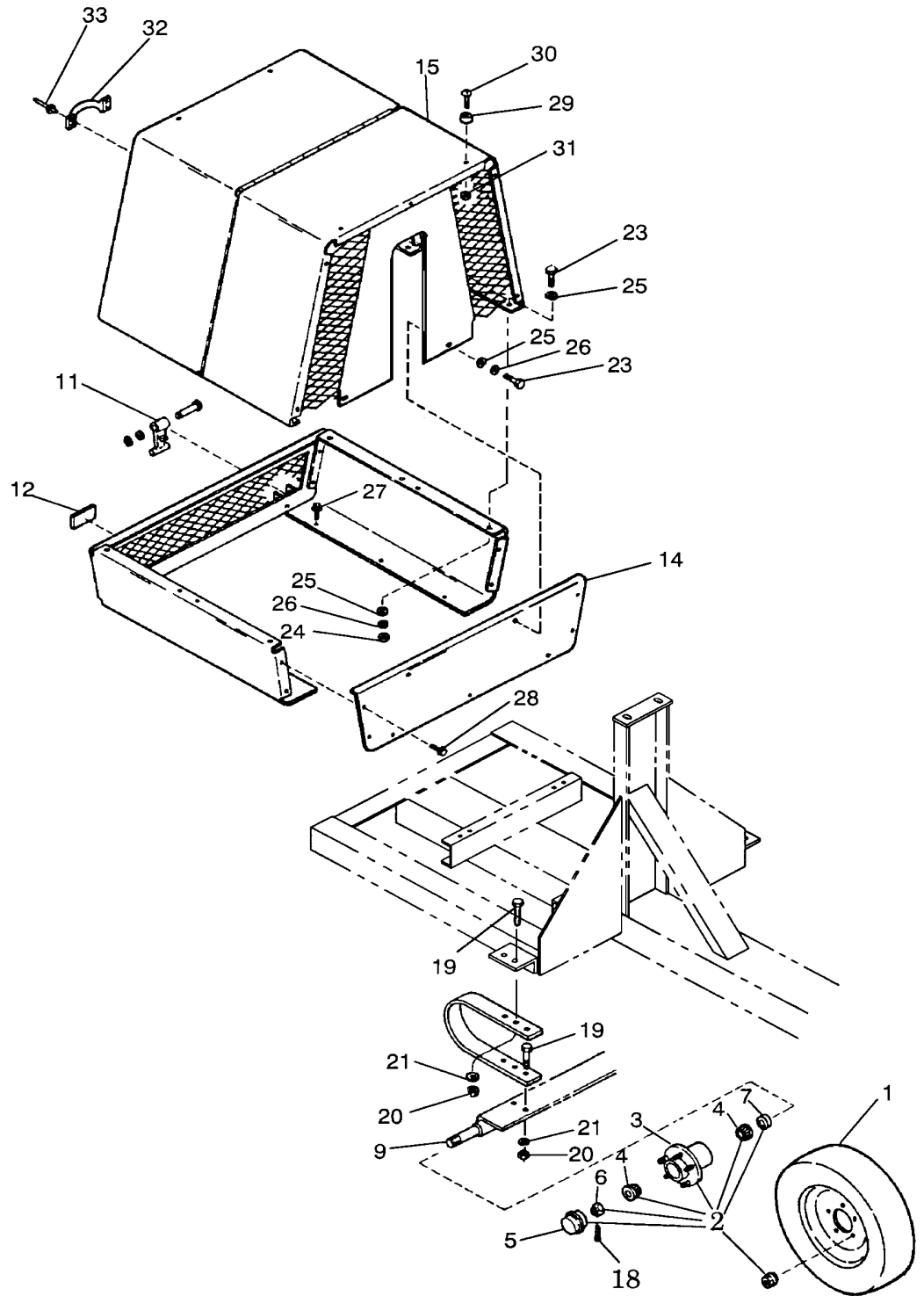

FIGURE 1

Frame, Engine Base and Tow Pole

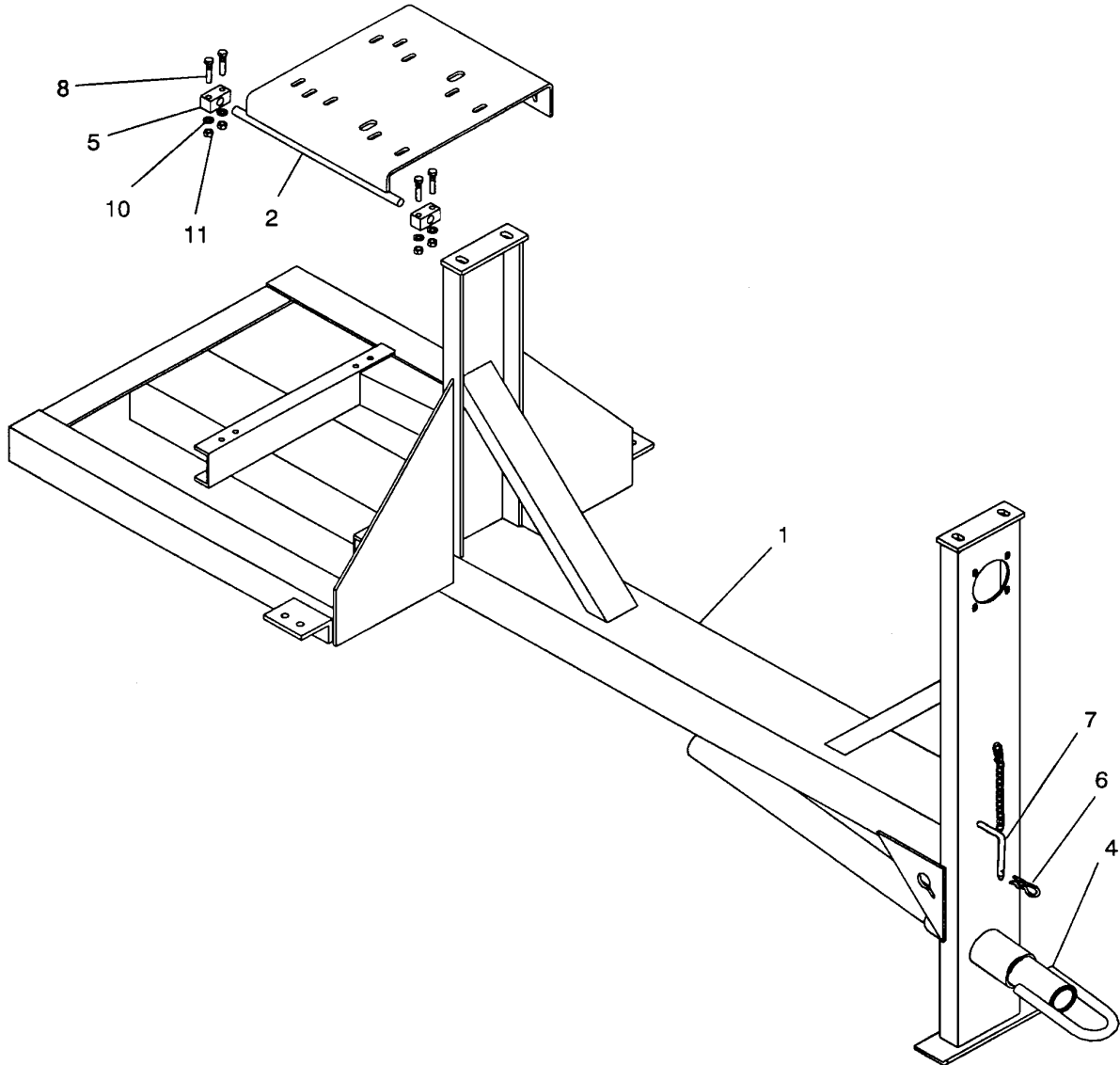

Figure 2

DRUM AND YOKE PARTS

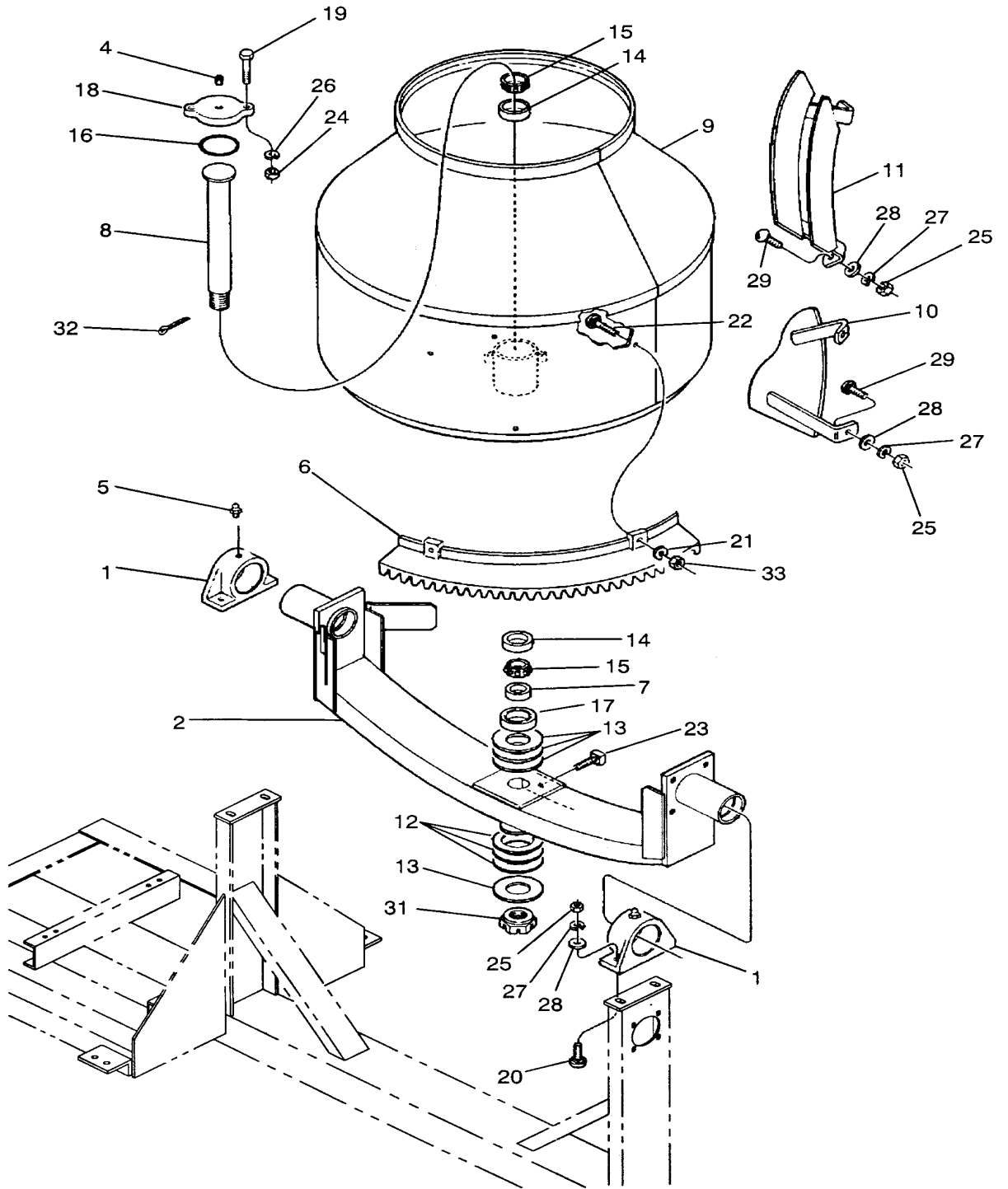

FIGURE 3

DRIVE AND TILT PARTS

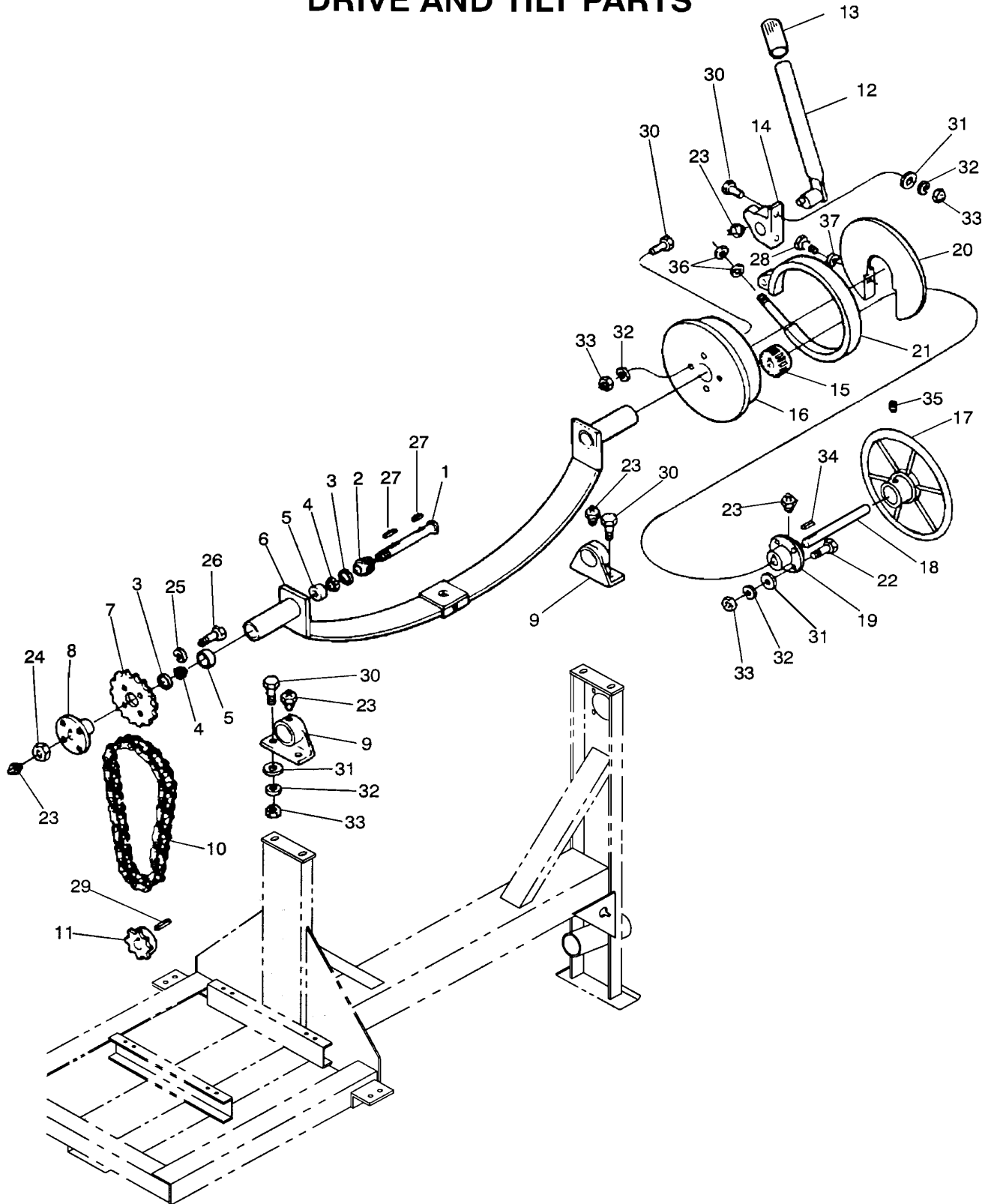

FIGURE 4

Free Manuals Download Website

<http://myh66.com>

<http://usermanuals.us>

<http://www.somanuals.com>

<http://www.4manuals.cc>

<http://www.manual-lib.com>

<http://www.404manual.com>

<http://www.luxmanual.com>

<http://aubethermostatmanual.com>

Golf course search by state

<http://golfingnear.com>

Email search by domain

<http://emailbydomain.com>

Auto manuals search

<http://auto.somanuals.com>

TV manuals search

<http://tv.somanuals.com>