

Goodman® TECHNICAL MANUAL

GPC 13 SEER R-410A Package Air Conditioners with R-410A

- Refer to Service Manual RS6300011 (Horizontal) for installation, operation, and troubleshooting information.
- All safety information must be followed as provided in the Service Manual.
- Refer to the appropriate Parts Catalog for part number information.
- Models listed on page 3.

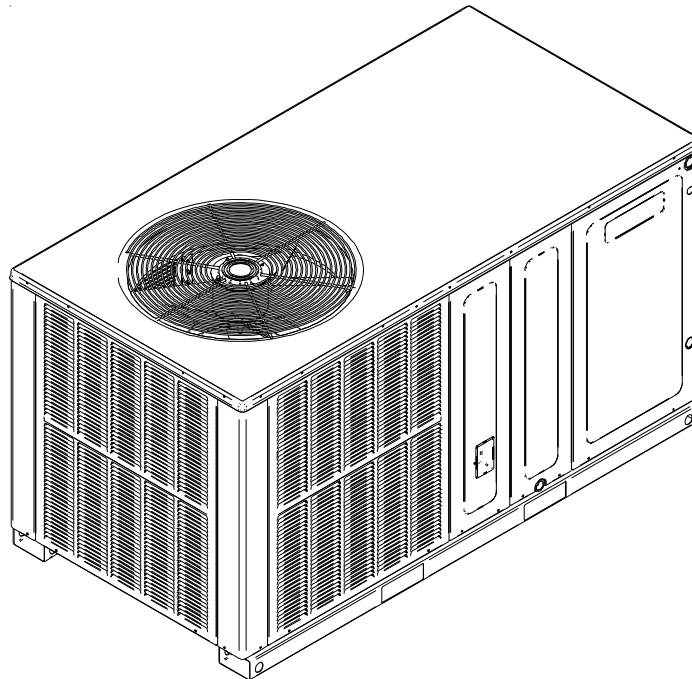

This manual is to be used by qualified, professionally trained HVAC technicians only. Goodman does not assume any responsibility for property damage or personal injury due to improper service procedures or services performed by an unqualified person.

RT6322006r6
September 2010

Copyright © 2008 - 2010 Goodman Manufacturing Company, L.P.

PRODUCT IDENTIFICATION

The model and manufacturing number are used for positive identification of component parts used in manufacturing. Please use these numbers when requesting service or parts information.

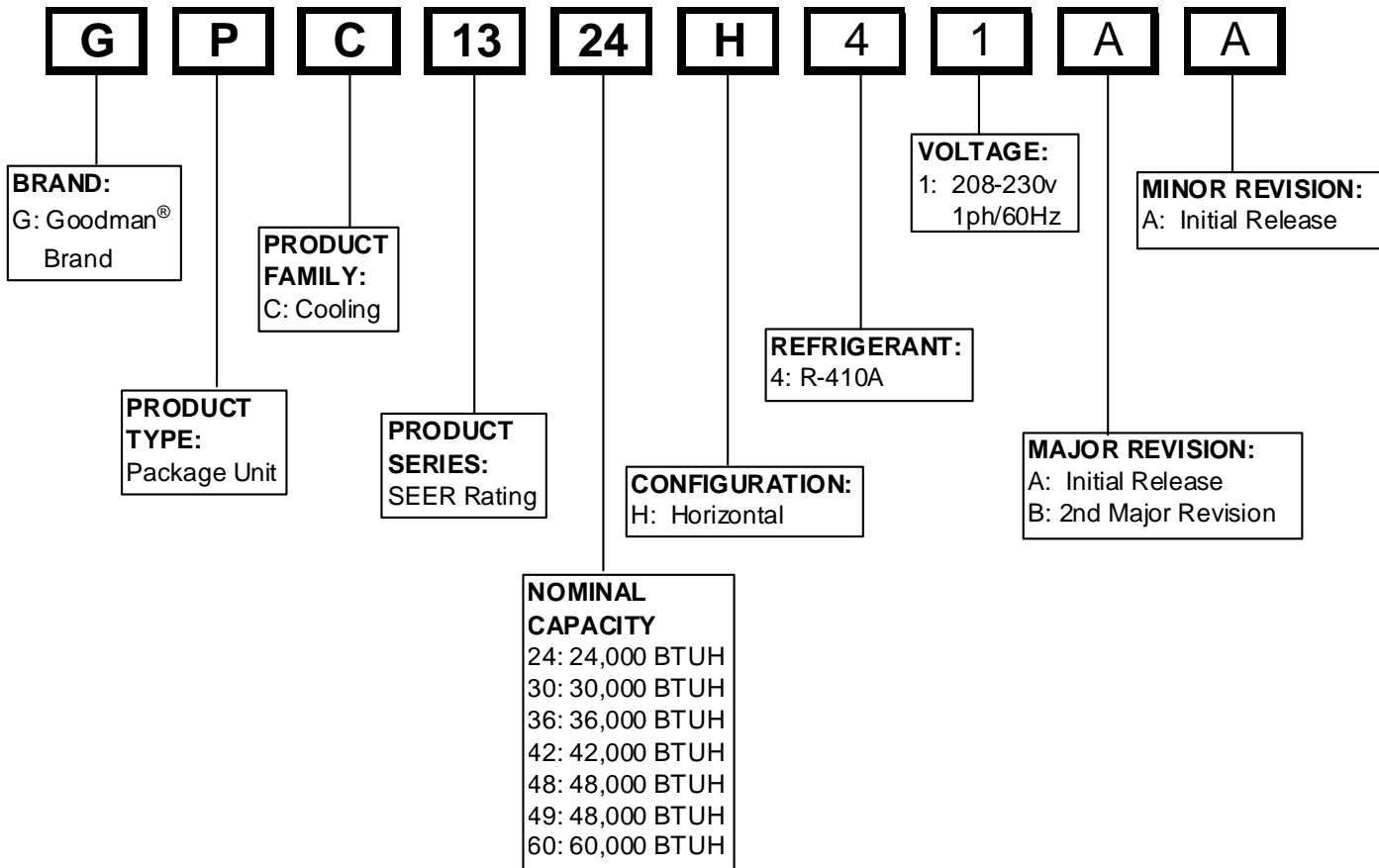

WARNING

HIGH VOLTAGE!
Disconnect ALL power before servicing or installing this unit. Multiple power sources may be present. Failure to do so may cause property damage, personal injury or death.

WARNING

Goodman will not be responsible for any injury or property damage arising from improper service or service procedures. If you install or perform service on this unit, you assume responsibility for any personal injury or property damage which may result. Many jurisdictions require a license to install or service heating and air conditioning equipment.

WARNING

Installation and repair of this unit should be performed ONLY by individuals meeting (at a minimum) the requirements of an "entry level technician" as specified by the Air-Conditioning, Heating, and Refrigeration Institute (AHRI). Attempting to install or repair this unit without such background may result in product damage, personal injury or death.

PRODUCT IDENTIFICATION

The model and manufacturing number are used for positive identification of component parts used in manufacturing. Please use these numbers when requesting service or parts information.

5MM

GPC1324H41AA

GPC1330H41AA

GPC1336H41AA

GPC1342H41AA

GPC1348H41BA

GPC1360H41BA

GPC1324H41AB

GPC1330H41AB

GPC1336H41AB

GPC1342H41AB

GPC1349H41AA

GPC1360H41BB

*5 mm model
specific information
begins on page 29.*

WARNING

The United States Environmental Protection Agency ("EPA") has issued various regulations regarding the introduction and disposal of refrigerants introduced into this unit. Failure to follow these regulations may harm the environment and can lead to the imposition of substantial fines. These regulations may vary by jurisdiction. Should questions arise, contact your local EPA office.

WARNING

Do not connect or use any device that is not design certified by Goodman for use with this unit. Serious property damage, personal injury, reduced unit performance and/or hazardous conditions may result from the use of such non-approved devices.

WARNING

To prevent the risk of property damage, personal injury, or death, do not store combustible materials or use gasoline or other flammable liquids or vapors in the vicinity of this appliance.

PRODUCT DESIGN

GPC Package Cooling Units are designed for outdoor installations only in either residential or light commercial applications.

The connecting ductwork (Supply and Return) can be connected for either horizontal or vertical airflow. In the vertical application a matching Roof Curb is recommended.

A return air filter must be installed behind the return air grille(s) or provision must be made for a filter in an accessible location within the return air duct. The minimum filter area should not be less than those sizes listed in the Specification Section. Under no circumstances should the unit be operated without return air filters.

A 3/4" PVC pipe is provided for removal of condensate water from the indoor coil. In order to provide proper condensate flow, a drain trap is supplied and shipped loose inside the unit for field installation. (Do not reduce the drain line size.)

Refrigerant flow control is achieved by use of restrictor orifices. GPC units use the FasTest Access Fitting System with a saddle that is either soldered to the suction and liquid lines or is fastened with a locking nut to the access fitting box (core) and then screwed into the saddle. **Do not remove the core from the saddle until the refrigerant charge has been removed. Failure to do so could result in property damage or personal injury.**

The single phase units use permanent split capacitor (PSC) design compressors. Starting components are therefore not required for these units. A low microfarad run capacitor assists the compressor to start and remains in the circuit during operation.

The outdoor fan and indoor blower motors are single phase capacitor type motors with the exception of the GPC1360H41* units which have X-13 indoor blower motors that are energized by a 24V signal from the thermostat and are constant torque motors with very low power consumption. The X-13 features an integral control module.

Air for condensing (cooling cycle) is drawn through the outdoor coil by a propeller fan, and is discharged vertically out the top of the unit. The outdoor coil is designed for .0 static. No additional restriction (ductwork) shall be applied.

Conditioned air is drawn through the filter(s), field installed, across the coil and back into the conditioned space by the indoor blower.

GPC1324-30H41* use Copeland Reciprocating Compressors.

- Due to their design Scroll Compressors are inherently more tolerant of liquid refrigerant. **NOTE:** Even though the compressor section of a Scroll compressor is more tolerant of liquid refrigerant, continued floodback or flooded start conditions may wash oil from the bearing surfaces causing premature bearing failure.
- Scroll Compressors use white oil which is compatible with 3GS oil which may be used if additional oil is required.
- Operating pressures and amp draws may differ from standard reciprocating compressors. This information may be found in the "Cooling Performance Data" section.

Location and Clearances

NOTE: To ensure proper condensate drainage, unit must be installed in a level position.

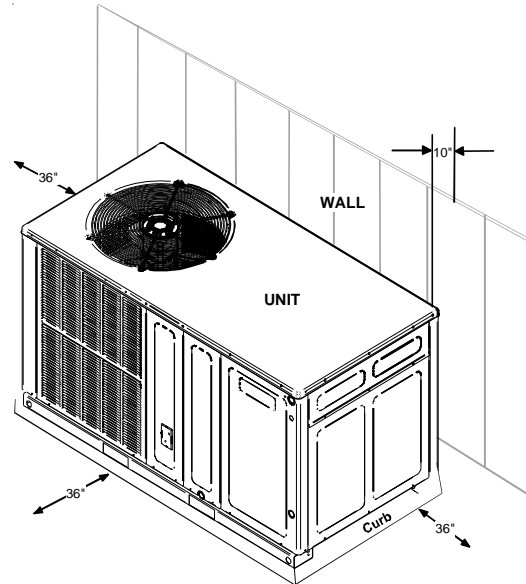

Outside Slab Installation - Horizontal (H)

Minimum clearances are required to avoid air recirculation and keep the unit operating at peak efficiency.

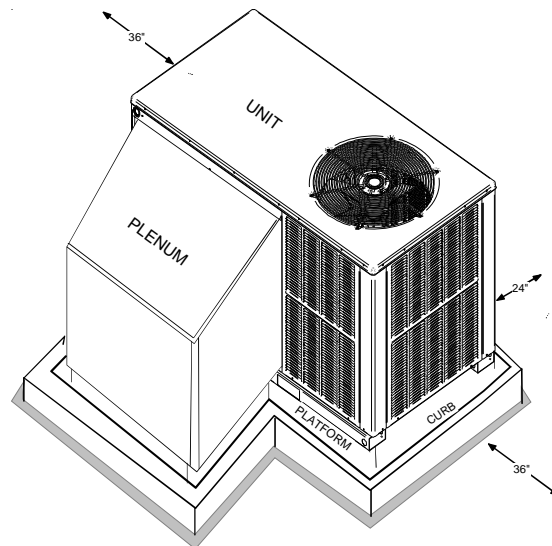

Rooftop Installation - Horizontal (H)

PRODUCT DESIGN

In installations where the unit is installed above ground level and not serviceable from the ground (Example: Roof Top installations), the installer must provide service platform for service person with rails or guards in accordance with local codes or ordinances or in their absence with the latest edition of the Uniform Mechanical Code Section 305.

NOTE: Unit can also use roof curb.

Refer to Roof Curb Installation Instructions for proper curb installation. Curbing must be installed in compliance with the National Roofing Contractors Association Manual.



WARNING

TO PREVENT POSSIBLE PROPERTY DAMAGE, THE UNIT SHOULD REMAIN IN AN UPRIGHT POSITION DURING ALL RIGGING AND MOVING OPERATIONS. TO FACILITATE LIFTING AND MOVING IF A CRANE IS USED, PLACE THE UNIT IN AN ADEQUATE CABLE SLING.

PRODUCT DIMENSIONS

GPC13[24-60]H41**

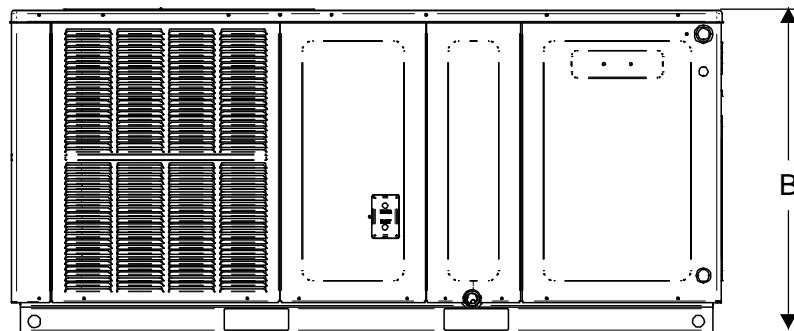
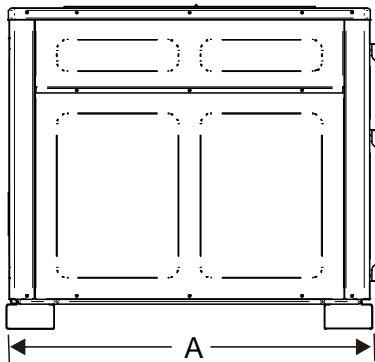
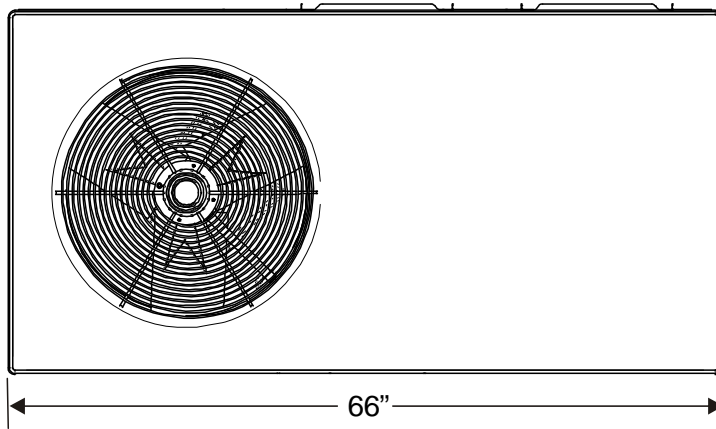

Chassis	Model	A	B
Small	GPC1324	33	30½
	GPC1330	33	30½
Medium	GPC1336	33	35½
	GPC1342	33	35½
	GPC1349	33	35½
Large	GPC1348	33	38½
	GPC1360	33	38½

Dimensions in inches

ACCESSORIES

GPC13[24-60]H41**

Part Number	Description
OT18-60A	Outdoor Thermostat Kit w/Lockout Stat
OT/EHR18-60	Emergency Heat Relay Kit
HKR	Electric Heat Kit
PCCP101-103	Roof Curb
PCP101-103	Downflow Plenum Kit
PCP101-103R8	Downflow Plenum Kit w/ R-8 Insulation
GPCED101-103	Downflow Economizer for GPC-(H) A/C - To Be Used With PCP101-103
GPHEH101-103	Downflow Economizer for GPH-(H) Heat Pump - To Be Used With PCP101-103
GPCEH101-103	Horizontal Economizer for GPC-(H) A/C
GPHEH101-103	Horizontal Economizer for GPH-(H) Heat Pump
PCMD101-103	Manual Damper - To Be Used With PCP101-103
PCMDM101-103	Motorized Damper - To Be Used With PCP101-103
GPHMD101-103	Manual Damper for Horizontal Applications
SQRPCH101	Square to Round Adapters 16"&14"
SQRPCH102-103	Square to Round Adapters 18"&14"
SQRPC101	Square to Round Adapter - For Use With PCCP101-103 Curb 16" Rounds
SQRPC102-103	Square to Round Adapter For Use With PCCP101-103 Curb 18" Rounds
PCFR101-103	External Horizontal Filter Rack
PCEF101-103	Elbow & Flashing w/ R-8 Liner
CDK36	Flush Mount Concentric Duct Kit
CDK36515	Flush Mount Concentric Duct Kit w/ Filter
CDK36530	Step Down Concentric Duct Kit
CDK36535	Step Down Concentric Duct Kit w/ Filter
CDK4872	Flush Mount Concentric Duct Kit
CDK4872515	Flush Mount Concentric Duct Kit w/ Filter
CDK4872530	Step Down Concentric Duct Kit
CDK4872535	Step Down Concentric Duct Kit w/ Filter

ELECTRICAL DATA (*Blower Only, Heat Mode)

Model and Heat Kit Usage	Circuit #1		Circuit #2		Actual kW & BTU at 240V
	Minimum Circuit Ampacity at 208 / 240V	Maximum Overcurrent Protection (amps) at 208 / 240V	Minimum Circuit Ampacity at 208 / 240V	Maximum Overcurrent Protection (amps) at 208 / 240V	
GPC1324H41*		--	--	--	--
HKR05*,C*	24 / 27	30 / 30	--	--	4.75 / 16,200
HKR08*,C*	33 / 38	40 / 40	--	--	7.0 / 23,800
HKR10*,C*	45 / 51	60 / 60	--	--	9.5 / 32,400
GPC1330H41*	2.4 / 2.4	--	--	--	--
HKR05*,C*	24 / 27	30 / 30	--	--	4.75 / 16,200
HKR08*,C*	34 / 39	40 / 40	--	--	7.0 / 23,800
HKR10*,C*	45 / 52	60 / 60	--	--	9.5 / 32,400
HKR15*,C*	45 / 52	60 / 60	22 / 25	30 / 30	14.25 / 48,600
GPC1336H41*		--	--	--	--
HKR05*,C*	24 / 27	30 / 30	--	--	4.75 / 16,200
HKR08*,C*	34 / 39	40 / 40	--	--	7.0 / 23,800
HKR10*,C*	45 / 52	60 / 60	--	--	9.5 / 32,400
HKR15*,C*	45 / 52	60 / 60	22 / 25	30 / 30	14.25 / 48,600
GPC1342H41*		--	--	--	--
HKR05*,C*	25 / 27	30 / 30	--	--	4.75 / 16,200
HKR08*,C*	34 / 39	40 / 40	--	--	7.0 / 23,800
HKR10*,C*	46 / 52	60 / 60	--	--	9.5 / 32,400
HKR15*,C*	46 / 52	60 / 60	22 / 25	30 / 30	14.25 / 48,600
HKR20*,C*	46 / 52	60 / 60	43 / 49	60 / 60	19.5 / 66,500
GPC1348H41*		--	--	--	--
HKR05*,C*	25 / 28	30 / 30	--	--	4.75 / 16,200
HKR08*,C*	34 / 40	40 / 40	--	--	7.0 / 23,800
HKR10*,C*	46 / 53	60 / 60	--	--	9.5 / 32,400
HKR15*,C*	46 / 52	60 / 60	22 / 25	30 / 30	14.25 / 48,600
HKR20*,C*	46 / 52	60 / 60	43 / 49	60 / 60	19.5 / 66,500
GPC1349H41*		--	--	--	--
HKR05*,C*	25 / 28	30 / 30	--	--	4.75 / 16,200
HKR08*,C*	34 / 40	40 / 40	--	--	7.0 / 23,800
HKR10*,C*	46 / 53	60 / 60	--	--	9.5 / 32,400
HKR15*,C*	46 / 52	60 / 60	22 / 25	30 / 30	14.25 / 48,600
HKR20*,C*	46 / 52	60 / 60	43 / 49	60 / 60	19.5 / 66,500
GPC1360H41*		--	--	--	--
HKR05*,C*	26 / 30	30 / 30	--	--	4.75 / 16,200
HKR08*,C*	36 / 40	40 / 40	--	--	7.0 / 23,800
HKR10*,C*	48 / 54	60 / 60	--	--	9.5 / 32,400
HKR15*,C*	48 / 54	60 / 60	22 / 25	30 / 30	14.25 / 48,600
HKR20*,C*	48 / 54	60 / 60	43 / 49	60 / 60	19.5 / 66,500

IMPORTANT NOTE: A separate power supply is required for the HKR heater kit.



WARNING

All wires and overcurrent protection devices are sized for use with electric heaters only and without refrigeration. If heaters are not installed with above wire size, overheating and fire could occur. See PACKAGE COOLING SPECIFICATIONS section for minimum circuit ampacity and maximum overcurrent protection during refrigeration cycle.

BLOWER PERFORMANCE DATA

GPC13[24-60]H41**

Dry Coil Data

Model	Speed	Volts	E.S.P (In. of H ₂ O)								
			0.1	0.2	0.3	0.4	0.5	0.6	0.7	0.8	
GPC1324H41**	Low	230	CFM	680	640	590	555	505	440	340	-
			WATTS	155	150	145	140	130	120	110	-
	Med	230	CFM	895	855	815	755	700	630	545	390
			WATTS	230	220	215	205	195	180	170	145
	High	230	CFM	1,185	1,130	1,070	1,010	930	850	760	650
			WATTS	350	340	325	310	295	280	265	245
GPC1330H41**	Low	230	CFM	1,150	1,080	1,025	975	925	845	-	-
			WATTS	340	330	315	305	295	280	-	-
	Med	230	CFM	1,335	1,275	1,205	1,135	1,075	985	910	845
			WATTS	425	415	400	385	370	350	330	310
	High	230	CFM	1,435	1,355	1,290	1,210	1,130	1,040	960	885
			WATTS	485	465	455	435	415	400	385	370
GPC1336H41**	Low	230	CFM	1,180	1,125	1,075	1,020	955	875	655	-
			WATTS	335	325	315	305	295	275	240	-
	Med	230	CFM	1,350	1,280	1,205	1,130	1,050	985	910	845
			WATTS	435	420	405	385	375	350	330	310
	High	230	CFM	1,450	1,370	1,290	1,205	1,130	1,040	960	885
			WATTS	495	480	465	440	425	400	385	370
GPC1342H41** GPC1349H41**	Low	230	CFM	1,425	1,410	1,355	1,310	1,245	1,170	1,080	-
			WATTS	450	445	430	420	405	390	370	-
	Med	230	CFM	1,620	1,595	1,545	1,485	1,425	1,345	1,250	1,160
			WATTS	550	540	525	510	495	475	450	425
	High	230	CFM	1,945	1,935	1,875	1,800	1,730	1,635	1,535	1,440
			WATTS	765	755	735	715	695	670	640	615
GPC1348H41**	Low	230	CFM	1,425	1,410	1,355	1,310	1,245	1,170	1,080	-
			WATTS	450	445	430	420	405	390	370	-
	Med	230	CFM	1,720	1,660	1,585	1,520	1,460	1,365	1,270	-
			WATTS	560	555	540	530	520	490	470	-
	High	230	CFM	2,110	2,060	1,980	1,895	1,795	1,705	1,590	1,500
			WATTS	785	780	765	745	720	705	665	625
GPC1360H41**	T1	230	CFM	1,775	1,635	1,645	1,515	1,510	1,450	1,430	1,400
			WATTS	395	420	435	445	455	465	470	475
	T2/T3	230	CFM	1,845	1,790	1,715	1,685	1,590	1,580	1,530	1,500
			WATTS	490	505	520	535	550	560	570	575
	T4/T5	230	CFM	2,025	1,900	1,840	1,780	1,725	1,650	1,620	1,580
			WATTS	575	595	620	630	645	655	660	670

NOTES:

1. Data shown is Dry Coil. Wet Coil Pressure Drop is approximate.
2. 0.1" H₂O, for 2 row indoor coil; 0.2" H₂O, for 3 row indoor coil; and 0.3" H₂O, for 4 row indoor coil.
3. Data shown does not include filter pressure drop, approx. 0.08" H₂O.
4. Reduce airflow by 2% for 208V operation.

BLOWER PERFORMANCE DATA

BTU OUTPUT vs TEMPERATURE RISE CHART

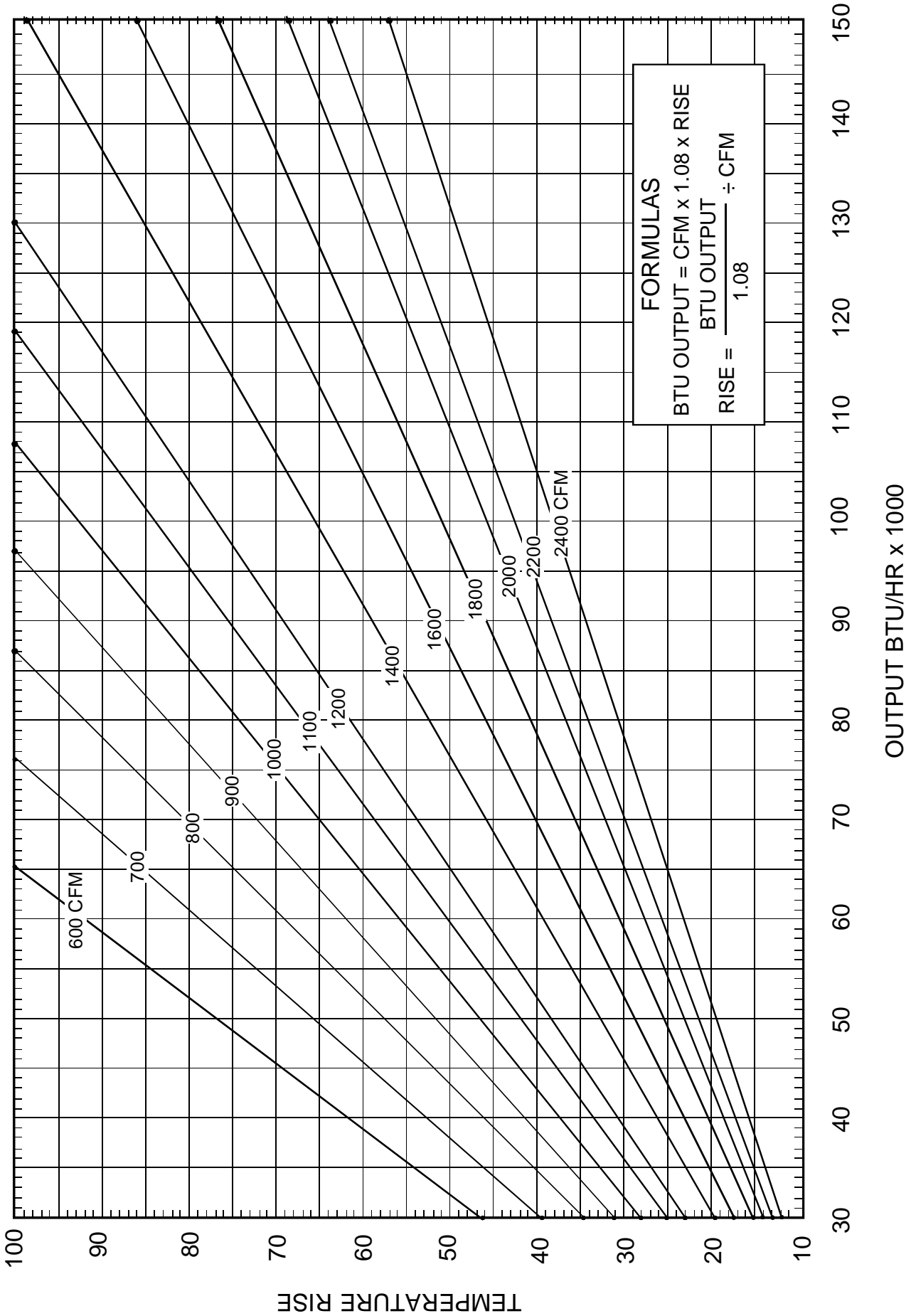

PACKAGE COOLING SPECIFICATIONS

GPC13[24-30]H41AA

		GPC1324H41*	GPC1330H41*
COOLING CAPACITY	COOLING CAPACITY, BTUH	24,000	28,600
	SEER	13.0	13.0
UNIT ELECTRICAL SPECIFICATION	VOLTAGE (NAMEPLATE)	208-230/1/60	208-230/1/60
	AMPS (TOTAL)	10.5	13.16
	MINIMUM CIRCUIT AMPACITY	12.5	15.6
	MAXIMUM OVERCURRENT PROTECTION ⁽¹⁾	20	25
COMPRESSOR	TYPE	RECIP	RECIP
	RATED LOAD AMPS	7.9	9.8
	LOCKED ROTOR AMPS	41	55
CONDENSER FAN MOTOR	HORSEPOWER	1/6	1/4
	RPM	815	830
	FULL LOAD AMPS	1.1	1.5
	LOCKED ROTOR AMPS	1.7	3.0
CONDENSER FAN	BLADE DIAMETER (INCHES) / # OF BLADES	22 / 3	22 / 3
CONDENSER COIL	FACE AREA - SQ. FT.	13.4	13.4
	NUMBER OF ROWS	1	1
	FINS PER INCH	24	24
EVAPORATOR BLOWER MOTOR	HORSEPOWER - NO. OF SPEEDS	1/4 - 3	1/3 - 3
	FULL LOAD AMPS	1.5	1.86
	LOCKED ROTOR AMPS	2.2	3.2
	MOTOR SPEED TAP - COOLING	MEDIUM	LOW
	RPM	1075	1075
EVAPORATOR BLOWER	DIAMETER X WIDTH (INCHES)	9 x 6	9 x 6
	RATED SCFM COOLING	815	1,080
	MAX EXTERNAL STATIC PRESS ("w.c.)	0.5	0.5
EVAPORATOR COIL	FACE AREA - SQ. FT.	4.6	4.6
	NUMBER OF ROWS	3	3
	FINS PER INCH	14	14
GENERAL INFORMATION	FILTER SIZE - SQ. FT. *	20 x 20 x 1	20 x 25 x 1
	DRAIN SIZE (INCHES)	3/4"	3/4"
	EXPANSION DEVICE	ORIFICE (0.059)	ORRIFICE (0.060)
	REFRIGERANT CHARGE R-410A (Oz.)	80	80
	POWER SUPPLY CONDUIT KNOCKOUT SIZE (IN.)	3/4, 1, 1-1/4	3/4, 1, 1-1/4
	LOW VOLTAGE CONDUIT KNOCKOUT SIZE (IN.)	1/2	1/2
	SHIPPING WEIGHT LBS.	310	310
	OPERATING WEIGHT LBS.	300	300

⁽¹⁾ Maximum Overcurrent Protection Device: **MUST** use Time Delay Fuse or HACR type Circuit Breaker of the same size as noted.
* Calculated external filter size based on air velocity of 300 ft/min.

Wire size should be determined in accordance with National Electrical Codes. Extensive wire runs will require larger wire sizes.
Unit specifications are subject to change without notice. **ALWAYS** refer to the units serial plate for the most up-to-date general and electrical information.

IMPORTANT: While this data is presented as a guide, it is important to electrically connect the unit and properly size wires and fuses/circuit breakers in accordance with the National Electrical Code and/or all local codes. Data shown is w/o electric heaters.

PACKAGE COOLING SPECIFICATIONS

GPC13[36-42]H41AA

		GPC1336H41*	GPC1342H41*
COOLING CAPACITY	COOLING CAPACITY, BTUH	36,000	41,000
	SEER	13.0	13.0
UNIT ELECTRICAL SPECIFICATION	VOLTAGE (NAMEPLATE)	208-230/1/60	208-230/1/60
	AMPS (TOTAL)	20.06	22.2
	MINIMUM CIRCUIT AMPACITY	24.2	26.6
	MAXIMUM OVERCURRENT PROTECTION ⁽¹⁾	40	40
COMPRESSOR	TYPE	SCROLL	SCROLL
	RATED LOAD AMPS	16.7	17.9
	LOCKED ROTOR AMPS	79	112
CONDENSER FAN MOTOR	HORSEPOWER	1/4	1/4
	RPM	830	1075
	FULL LOAD AMPS	1.5	1.4
	LOCKED ROTOR AMPS	3.0	2.9
CONDENSER FAN	BLADE DIAMETER (INCHES) / # OF BLADES	22 / 4	22 / 4
CONDENSER COIL	FACE AREA - SQ. FT.	13.4	17.0
	NUMBER OF ROWS	1	1
	FINS PER INCH	24	24
EVAPORATOR BLOWER MOTOR	HORSEPOWER - NO. OF SPEEDS	1/3 - 3	1/2 - 3
	FULL LOAD AMPS	1.86	2.87
	LOCKED ROTOR AMPS	3.2	4.9
	MOTOR SPEED TAP - COOLING	LOW	LOW
	RPM	1075	1075
EVAPORATOR BLOWER	DIAMETER X WIDTH (INCHES)	9 x 8	10 x 8
	RATED SCFM COOLING	1,205	1,410
	MAX EXTERNAL STATIC PRESS ("w.c.)	0.5	0.5
EVAPORATOR COIL	FACE AREA - SQ. FT.	5.2	6.2
	NUMBER OF ROWS	3	4
	FINS PER INCH	14	14
GENERAL INFORMATION	FILTER SIZE - SQ. FT. *	25 x 25 x 1	(2) 20 x 20 x 1
	DRAIN SIZE (INCHES)	3/4"	3/4"
	EXPANSION DEVICE	ORIFICE (0.065)	ORIFICE (0.072)
	REFRIGERANT CHARGE R-410A (Oz.)	85	105
	POWER SUPPLY CONDUIT KNOCKOUT SIZE (IN.)	3/4, 1, 1-1/4	3/4, 1, 1-1/4
	LOW VOLTAGE CONDUIT KNOCKOUT SIZE (IN.)	1/2	1/2
	SHIPPING WEIGHT LBS.	370	370
	OPERATING WEIGHT LBS.	360	360

⁽¹⁾ Maximum Overcurrent Protection Device: **MUST** use Time Delay Fuse or HACR type Circuit Breaker of the same size as noted.
* Calculated external filter size based on air velocity of 300 ft/min.

Wire size should be determined in accordance with National Electrical Codes. Extensive wire runs will require larger wire sizes.
Unit specifications are subject to change without notice. **ALWAYS** refer to the units serial plate for the most up-to-date general and electrical information.

IMPORTANT: While this data is presented as a guide, it is important to electrically connect the unit and properly size wires and fuses/circuit breakers in accordance with the National Electrical Code and/or all local codes. Data shown is w/o electric heaters.

PACKAGE COOLING SPECIFICATIONS

GPC13[48-60]H41BA

		GPC1348H41B*	GPC1360H41B*
COOLING CAPACITY	COOLING CAPACITY, BTUH	45,500	57,500
	SEER	13.0	13.0
UNIT ELECTRICAL SPECIFICATION	VOLTAGE (NAMEPLATE)	208-230/1/60	208-230/1/60
	AMPS (TOTAL)	24.17	33.6
	MINIMUM CIRCUIT AMPACITY	29.2	40.2
	MAXIMUM OVERCURRENT PROTECTION ⁽¹⁾	45	60
COMPRESSOR	TYPE	SCROLL	SCROLL
	RATED LOAD AMPS	19.9	26.4
	LOCKED ROTOR AMPS	109	134
CONDENSER FAN MOTOR	HORSEPOWER	1/4	1/4
	RPM	1075	1075
	FULL LOAD AMPS	1.4	1.4
	LOCKED ROTOR AMPS	2.9	2.9
CONDENSER FAN	BLADE DIAMETER (INCHES) /# OF BLADES	22 / 4	22 / 4
CONDENSER COIL	FACE AREA - SQ. FT.	19.1	19.1
	NUMBER OF ROWS	1	2
	FINS PER INCH	21	16
EVAPORATOR BLOWER MOTOR	HORSEPOWER - NO. OF SPEEDS	1/2 - 3	3/4 - 3
	FULL LOAD AMPS	2.87	5.8
	LOCKED ROTOR AMPS	4.9	NA
	MOTOR SPEED TAP - COOLING	MEDIUM	T2
	RPM	1075	1075
EVAPORATOR BLOWER	DIAMETER X WIDTH (INCHES)	10 x 8	11 x 8
	RATED SCFM COOLING	1,585	1,850
	MAX EXTERNAL STATIC PRESS ("w.c.)	0.5	0.5
EVAPORATOR COIL	FACE AREA - SQ. FT.	6.2	7.0
	NUMBER OF ROWS	4	4
	FINS PER INCH	14	14
GENERAL INFORMATION	FILTER SIZE - SQ. FT. *	(2) 20 x 20 x 1	(2) 20 x 25 x 1
	DRAIN SIZE (INCHES)	3/4"	3/4"
	EXPANSION DEVICE	ORRIFICE (0.076)	ORIFICE (0.088)
	REFRIGERANT CHARGE R-410A (Oz.)	110	160
	POWER SUPPLY CONDUIT KNOCKOUT SIZE (IN.)	3/4, 1, 1-1/4	3/4, 1, 1-1/4
	LOW VOLTAGE CONDUIT KNOCKOUT SIZE (IN.)	1/2	1/2
	SHIPPING WEIGHT LBS.	400	400
	OPERATING WEIGHT LBS.	390	390

⁽¹⁾ Maximum Overcurrent Protection Device: **MUST** use Time Delay Fuse or HACR type Circuit Breaker of the same size as noted.
 * Calculated external filter size based on air velocity of 300 ft/min.

Wire size should be determined in accordance with National Electrical Codes. Extensive wire runs will require larger wire sizes.
 Unit specifications are subject to change without notice. **ALWAYS** refer to the units serial plate for the most up-to-date general and electrical information.

IMPORTANT: While this data is presented as a guide, it is important to electrically connect the unit and properly size wires and fuses/circuit breakers in accordance with the National Electrical Code and/or all local codes. Data shown is w/o electric heaters.

COOLING PERFORMANCE DATA

GPC1324H41AA

MODEL: GPC1324H41A* EXPANDED PERFORMANCE DATA COOLING OPERATION

Design Subcooling, 12±3 °F @ the liquid access fitting connection AHRI 95 test conditions. Design Superheat 8±3 °F @ the compressor suction access fitting connection.

IDB*	Airflow	Outdoor Ambient Temperature																																																																																																																																																																																																																																																																																																																																																																																																																																																																																																																																																																																																																																																																																																																																																																																																																																																																																																																																																																																																																																																																																																																																																																																																																																																																																																																																																																														
		65					75					85					95					105					115																																																																																																																																																																																																																																																																																																																																																																																																																																																																																																																																																																																																																																																																																																																																																																																																																																																																																																																																																																																																																																																																																																																																																																																																																																																																																																																																																					
		59	63	67	71	75	59	63	67	71	75	59	63	67	71	75	59	63	67	71	75	59	63	67	71	75	59	63	67	71	75																																																																																																																																																																																																																																																																																																																																																																																																																																																																																																																																																																																																																																																																																																																																																																																																																																																																																																																																																																																																																																																																																																																																																																																																																																																																																																																																																	
70	980	MBh	23.5	24.4	26.7	-	23.0	23.8	26.1	-	22.4	23.2	25.5	-	21.9	22.7	24.8	-	20.8	21.5	23.6	-	19.3	20.0	21.9	-	0.78	0.65	0.45	-	0.83	0.70	0.48	-	0.86	0.72	0.50	-	0.89	0.74	0.52	-	1.7	1.5	1.1	-	1.8	1.5	1.2	-	1.7	1.5	1.1	-	1.6	1.4	1.1	-	1.83	1.74	1.79	-	1.94	1.98	2.05	-	2.04	2.08	2.15	-	2.12	2.17	2.24	-	2.20	2.24	2.32	-	7.1	7.3	7.5	-	8.2	8.3	8.6	-	8.7	8.8	9.1	-	9.1	9.3	9.6	-	9.6	9.8	10.1	-	222	239	252	-	283	305	322	-	323	347	367	-	363	391	413	-	401	432	456	-	112	119	130	-	118	126	137	-	123	131	143	-	129	137	150	-	135	144	157	-	140	149	163	-																																																																																																																																																																																																																																																																																																																																																																																																																																																																																																																																																																																																																																																																																																																																																																																																																																																																																																																																																																																																																																																																																																																																																																																																																																		
		ST	0.78	0.65	0.45	-	0.83	0.70	0.48	-	0.86	0.72	0.50	-	0.89	0.74	0.52	-	0.92	0.78	0.54	-	0.95	0.81	0.57	-	0.98	0.84	0.60	-	1.01	0.87	0.63	-	1.04	0.90	0.66	-	1.07	0.93	0.69	-	1.10	0.96	0.72	-	1.13	1.00	0.76	-	1.16	1.03	0.79	-	1.19	1.06	0.82	-	1.22	1.09	0.85	-	1.25	1.12	0.88	-	1.28	1.15	0.91	-	1.31	1.18	0.94	-	1.34	1.21	0.97	-	1.37	1.24	1.00	-	1.40	1.27	1.03	-	1.43	1.30	1.06	-	1.46	1.33	1.09	-	1.49	1.36	1.12	-	1.52	1.39	1.15	-	1.55	1.42	1.18	-	1.58	1.45	1.21	-	1.61	1.48	1.24	-	1.64	1.51	1.27	-	1.67	1.54	1.30	-	1.70	1.57	1.33	-	1.73	1.60	1.36	-	1.76	1.63	1.39	-	1.79	1.66	1.42	-	1.82	1.69	1.45	-	1.85	1.72	1.48	-	1.88	1.75	1.51	-	1.91	1.78	1.54	-	1.94	1.81	1.57	-	1.97	1.84	1.60	-	2.00	1.87	1.63	-	2.03	1.90	1.66	-	2.06	1.93	1.69	-	2.09	1.96	1.72	-	2.12	2.00	1.75	-	2.15	2.03	1.78	-	2.18	2.06	1.81	-	2.21	2.09	1.84	-	2.24	2.12	1.87	-	2.27	2.15	1.90	-	2.30	2.18	1.93	-	2.33	2.21	1.96	-	2.36	2.24	1.99	-	2.39	2.27	2.02	-	2.42	2.30	2.05	-	2.45	2.33	2.08	-	2.48	2.36	2.11	-	2.51	2.39	2.14	-	2.54	2.42	2.17	-	2.57	2.45	2.20	-	2.60	2.48	2.23	-	2.63	2.51	2.26	-	2.66	2.54	2.29	-	2.69	2.57	2.32	-	2.72	2.60	2.35	-	2.75	2.63	2.38	-	2.78	2.66	2.41	-	2.81	2.69	2.44	-	2.84	2.72	2.47	-	2.87	2.75	2.50	-	2.90	2.78	2.53	-	2.93	2.81	2.56	-	2.96	2.84	2.59	-	2.99	2.87	2.62	-	3.02	2.90	2.65	-	3.05	2.93	2.68	-	3.08	2.96	2.71	-	3.11	2.99	2.74	-	3.14	3.02	2.77	-	3.17	3.05	2.80	-	3.20	3.08	2.83	-	3.23	3.11	2.86	-	3.26	3.14	2.89	-	3.29	3.17	2.92	-	3.32	3.20	2.95	-	3.35	3.23	2.98	-	3.38	3.26	3.01	-	3.41	3.29	3.04	-	3.44	3.32	3.07	-	3.47	3.35	3.10	-	3.50	3.38	3.13	-	3.53	3.41	3.16	-	3.56	3.44	3.19	-	3.59	3.47	3.22	-	3.62	3.50	3.25	-	3.65	3.53	3.28	-	3.68	3.56	3.31	-	3.71	3.59	3.34	-	3.74	3.62	3.37	-	3.77	3.65	3.40	-	3.80	3.68	3.43	-	3.83	3.71	3.46	-	3.86	3.74	3.49	-	3.89	3.77	3.52	-	3.92	3.80	3.55	-	3.95	3.83	3.58	-	3.98	3.86	3.61	-	4.01	3.89	3.64	-	4.04	3.92	3.67	-	4.07	3.95	3.70	-	4.10	3.98	3.73	-	4.13	4.01	3.76	-	4.16	4.04	3.79	-	4.19	4.07	3.82	-	4.22	4.10	3.85	-	4.25	4.13	3.88	-	4.28	4.16	3.91	-	4.31	4.19	3.94	-	4.34	4.22	3.97	-	4.37	4.25	4.00	-	4.40	4.28	4.03	-	4.43	4.31	4.06	-	4.46	4.34	4.09	-	4.49	4.37	4.12	-	4.52	4.40	4.15	-	4.55	4.43	4.18	-	4.58	4.46	4.21	-	4.61	4.49	4.24	-	4.64	4.52	4.27	-	4.67	4.55	4.30	-	4.70	4.58	4.33	-	4.73	4.61	4.36	-	4.76	4.64	4.39	-	4.79	4.67	4.42	-	4.82	4.70	4.45	-	4.85	4.73	4.48	-	4.88	4.76	4.51	-	4.91	4.79	4.54	-	4.94	4.82	4.57	-	4.97	4.85	4.60	-	5.00	4.88	4.63	-	5.03	4.91	4.66	-	5.06	4.94	4.69	-	5.09	4.97	4.72	-	5.12	5.00	4.75	-	5.15	5.03	4.78	-	5.18	5.06	4.81	-	5.21	5.09	4.84	-	5.24	5.12	4.87	-	5.27	5.15	4.90	-	5.30	5.18	4.93	-	5.33	5.21	4.96	-	5.36	5.24	4.99	-	5.39	5.27	5.02	-	5.42	5.30	5.05	-	5.45	5.33	5.08	-	5.48	5.36	5.11	-	5.51	5.39	5.14	-	5.54	5.42	5.17	-	5.57	5.45	5.20	-	5.60	5.48	5.23	-	5.63	5.51	5.26	-	5.66	5.54	5.29	-	5.69	5.57	5.32	-	5.72	5.60	5.35	-	5.75	5.63	5.38	-	5.78	5.66	5.41	-	5.81	5.69	5.44	-	5.84	5.72	5.47	-	5.87	5.75	5.50	-	5.90	5.78	5.53	-	5.93	5.81	5.56	-	5.96	5.84	5.59	-	5.99	5.87	5.62	-	6.02	5.90	5.65	-	6.05	5.93	5.68	-	6.08	5.96	5.71	-	6.11	5.99	5.74	-	6.14	6.02	5.77	-	6.17	6.05	5.80	-	6.20	6.08	5.83	-	6.23	6.11	5.86	-	6.26	6.14	5.89	-	6.29	6.17	5.92	-	6.32	6.20	5.95	-	6.35	6.23	5.98	-	6.38	6.26	6.01	-	6.41	6.29	6.04	-	6.44	6.32	6.07	-	6.47	6.35	6.10	-	6.50	6.38	6.13	-	6.53	6.41	6.16	-	6.56	6.44	6.19	-	6.59	6.47	6.22	-	6.62	6.50	6.25	-	6.65	6.53	6.28	-	6.68	6.56	6.31	-	6.71	6.59	6.34	-	6.74	6.62	6.37	-	6.77	6.65	6.40	-	6.80	6.68	6.43	-	6.83	6.71	6.46	-	6.86	6.74	6.49	-	6.89	6.77	6.52	-	6.92	6.80	6.55	-	6.95	6.83	6.58	-	6.98	6.86	6.61	-	7.01	6.89	6.64	-	7.04	6.92	6.67	-	7.07	6.95	6.70	-	7.10	6.98	6.73	-	7.13	7.01	6.76	-	7.16	7.04	6.79	-	7.19	7.07	6.82	-	7.22	7.10	6.85	-	7.25	7.13	6.88	-	7.28	7.16	6.91	-	7.31	7.19	6.94	-	7.34	7.22	6.97	-	7.37	7.25	7.00	-	7.40	7.28	7.03	-	7.43	7.31	7.06	-	7.46	7.34	7.09	-	7.49	7.37	7.12	-	7.52	7.40	7.15	-	7.55	7.43	7.18	-	7.58	7.46	7.21	-	7.61	7.49	7.24	-	7.64	7.52	7.27	-	7.67	7.55	7.30	-	7.70	7.58	7.33	-	7.73	7.61	7.36	-	7.76	7.64	7.39	-	7.79	7.67	7.42	-	7.82	7.70	7.45	-	7.85	7.73	7.48	-	7.88	7.76	7.51	-	7.91	7.79	7.54	-	7.94	7.82	7.57	-	7.97	7.85	7.60	-	8.00	7.88	7.63	-	8.03	7.91	7.66	-	8.06	7.94	7.69	-	8.09	7.97	7.72	-	8.12	8.00	7.75	-	8.15	8.03	7.78	-	8.18	8.06	7.81	-	8.21	8.09	7.84	-	8.24	8.12	7.87	-	8.27	8.15	7.90	-	8.30	8.18	7.93	-	8.33	8.21	7.96	-	8.36	8.24	7.99	-	8.39	8.27	8.02	-	8.42	8.30	8.05	-	8.45	8.33	8.08	-	8.48	8.36	8.11	-	8.51	8.39	8.14	-	8.54	8.42	8.17	-	8.57	8.45	8.20	-	8.60	8.48	8.23	-	8.63	8.51	8.26	-	8.66	8.54	8.29	-	8.69	8.57	8.32	-	8.72	8.60	8.35	-	8.75	8.63	8.38	-	8.78	8.66	8.41	-	8.81	8.69	8.44	-	8.84	8.72	8.47	-	8.87	8.75	8.50	-	8.90	8.78	8.53	-	8.93	8.81	8.56	-	8.96	8.84	8.59	-	8.99	8.87	8.62	-	9.02	8.90	8.65	-	9.05	8.93	8.68	-	9.08	8.96	8.71	-	9.11	8.99	8.74	-	9.14	9.02	8.77	-	9.17	9.05	8.80	-	9.20	9.08	8.83	-	9.23	9.11	8.86	-	9.26	9.14	8.89	-	9.29	9.17	8.92	-	9.32	9.20	8.95	-	9.35	9.23	8.98	-	9.38	9.26	9.01	-	9.41	9.29	9.04	-	9.44	9.32	9.07	-	9.47	9.35	9.10	-	9.50	9.38	9.13	-	9.53	9.41	9.16	-	9.56	9.44	9.19	-	9.59	9.47	9.22	-	9.62	9.50	9.25	-	9.65	9.53	9.28	-	9.68	9.56	9.31	-	9.71	9.59	9.34	-	9.74	9.62	9.37	-	9.77	9.65	9.40	-	9.80	9.68	9.43	-	9.83	9.71	9.46	-	9.86	9.74	9.49	-	9.89	9.77	9.52	-	9.92	9.80	9.55	-	9.95	9.83	9.58	-	9.98	9.86	9.61	-	10.01	9.89	9.64	-	10.04	9.92	9.67	-	10.07	9.95	9.70	-	10.10	9.98	9.73	-	10.13	10.01	9.76	-	10.16	10.04	9.79	-	10.19	10.07	9.82	-	10.22	10.10	9.85	-	10.25	10.13	9.88	-	10.28	10.16	9.91	-	10.31	10.19	9.94	-	10.34	10.22	9.97	-	10.37	10.25	10.00	-	10.40	10.28	10.03	-	10.43	10.31	10.06	-	10.46	10.34	10.09	-	10.49	10.37	10.12	-	10.52	10.40	10.15	-	10.55	10.43	10.18	-	10.58	10.46	10.21	-	10.61	10.49	10.24	-	10.64	10.52	10.27	-	10.67	10.55	10.30	-	10.70	10.58	10.33	-	10.73	10.6

COOLING PERFORMANCE DATA

GPC1324H41AA

EXPANDED PERFORMANCE DATA

EXPANDED PERFORMANCE DATA

MODEL: GPC1324H41A*

COOLING OPERATION

Design Subcooling, 12±3 °F @ the liquid access fitting connection AHRI 95 test conditions. Design Superheat 8±3 °F @ the compressor suction access fitting connection.

IDB*	Airflow	Outdoor Ambient Temperature																								
		65					75					85					105					115				
		59	63	67	71	75	59	63	67	71	75	59	63	67	71	75	59	63	67	71	75	59	63	67	71	75
980	MBh	24.3	24.9	26.6	28.4	23.8	24.3	26.0	27.7	23.2	23.7	25.3	27.1	22.6	23.1	24.7	26.4	21.5	22.0	23.5	25.1	19.9	20.4	21.8	23.3	
	ST	1.00	0.92	0.75	0.56	1.00	0.95	0.77	0.58	1.00	1.00	0.79	0.59	1.00	1.00	0.82	0.61	1.00	1.00	0.85	0.63	1.00	1.00	0.86	0.64	
	Delta T	23	21	19	15	22	22	19	15	22	22	19	15	20	21	19	15	20	21	19	15	19	19	17	14	
	KW	1.73	1.77	1.82	1.88	1.86	1.90	1.96	2.02	1.97	2.02	2.08	2.15	2.07	2.12	2.19	2.26	2.16	2.21	2.28	2.35	2.23	2.28	2.36	2.43	
	AMPS	7.2	7.4	7.6	7.8	7.7	7.9	8.1	8.4	8.3	8.5	8.7	9.0	8.8	9.0	9.3	9.6	9.3	9.5	9.8	10.1	9.8	10.0	10.3	10.7	
	HI PR	227	244	257	269	254	274	289	301	289	311	329	343	329	354	374	390	371	399	421	439	409	441	465	485	
	LO PR	114	122	133	141	121	128	140	149	126	134	146	155	132	140	153	163	138	147	160	171	143	152	166	177	
	MBh	23.6	24.1	25.8	27.6	23.1	23.6	25.2	26.9	22.5	23.0	24.6	26.3	22.0	22.5	24.0	25.7	20.9	21.3	22.8	24.4	19.3	19.8	21.1	22.6	
	ST	0.93	0.87	0.71	0.53	0.97	0.91	0.74	0.55	0.99	0.93	0.76	0.56	1.00	0.96	0.78	0.58	1.00	0.99	0.81	0.61	1.00	1.00	0.82	0.61	
	875	Delta T	23	22	19	15	23	22	20	16	23	22	20	16	23	23	20	16	22	22	19	15	20	21	18	14
KW		1.72	1.75	1.81	1.86	1.85	1.88	1.94	2.00	1.96	2.00	2.06	2.13	2.06	2.10	2.17	2.24	2.14	2.19	2.26	2.33	2.21	2.26	2.34	2.41	
AMPS		7.2	7.3	7.5	7.8	7.7	7.8	8.1	8.3	8.2	8.4	8.7	8.9	8.7	8.9	9.2	9.5	9.2	9.4	9.7	10.0	9.7	9.9	10.2	10.6	
HI PR		224	241	255	266	252	271	286	298	286	308	325	339	326	351	371	386	367	395	417	435	405	436	461	480	
LO PR		113	120	131	140	120	127	139	148	124	132	144	154	131	139	152	161	137	146	159	169	141	151	164	175	
MBh		22.5	22.9	24.5	26.2	21.9	22.4	23.9	25.6	21.4	21.9	23.4	25.0	20.9	21.3	22.8	24.4	19.8	20.3	21.7	23.2	18.4	18.8	20.1	21.4	
ST		0.89	0.84	0.68	0.51	0.92	0.87	0.71	0.53	0.95	0.89	0.72	0.54	0.98	0.92	0.75	0.56	1.02	0.95	0.78	0.58	1.02	0.96	0.78	0.58	
Delta T		24	23	20	16	24	23	20	16	24	23	20	16	24	23	20	16	24	23	20	16	22	22	19	15	
KW		1.69	1.73	1.78	1.83	1.82	1.85	1.91	1.97	1.93	1.97	2.03	2.09	2.02	2.07	2.13	2.20	2.11	2.15	2.22	2.29	2.18	2.23	2.30	2.37	
AMPS		7.1	7.2	7.4	7.6	7.6	7.7	7.9	8.2	8.1	8.3	8.5	8.8	8.6	8.8	9.0	9.3	9.1	9.3	9.5	9.9	9.5	9.8	10.0	10.4	
770	HI PR	220	237	250	261	247	265	280	292	281	302	319	333	320	344	363	379	360	387	409	426	397	427	451	471	
	LO PR	111	118	129	137	117	125	136	145	122	130	141	151	128	136	149	158	134	143	156	166	139	148	161	172	

980	MBh	24.8	25.2	26.4	28.2	24.2	24.7	25.8	27.6	23.6	24.1	25.2	26.9	23.0	23.5	24.6	26.2	21.9	22.3	23.4	24.9	20.3	20.7	21.6	23.1
	ST	1.00	0.99	0.89	0.72	1.00	1.00	0.92	0.75	1.00	1.00	0.95	0.77	1.00	1.00	0.98	0.79	1.00	1.00	0.90	0.82	1.00	1.00	0.86	0.83
	Delta T	23	23	22	19	23	23	22	19	22	23	22	19	22	22	23	20	21	21	22	19	19	19	20	18
	KW	1.74	1.78	1.84	1.89	1.87	1.91	1.97	2.04	1.99	2.03	2.10	2.16	2.09	2.14	2.20	2.28	2.18	2.22	2.30	2.37	2.25	2.30	2.38	2.45
	AMPS	7.3	7.4	7.6	7.9	7.8	8.0	8.2	8.4	8.4	8.5	8.8	9.1	8.9	9.1	9.3	9.6	9.4	9.6	9.9	10.2	9.9	10.1	10.4	10.7
	HI PR	229	246	260	271	257	276	292	304	292	314	332	346	333	358	378	394	374	403	425	444	413	445	470	490
	LO PR	115	123	134	143	122	130	142	151	127	135	147	157	133	142	155	165	140	148	162	173	144	154	168	179
	MBh	24.0	24.5	25.7	27.4	23.5	23.9	25.1	26.8	22.9	23.4	24.5	26.1	22.4	22.8	23.9	25.5	21.2	21.7	22.7	24.2	19.7	20.1	21.0	22.4
	ST	0.98	0.94	0.85	0.69	1.00	0.98	0.88	0.71	1.00	1.00	0.90	0.73	1.00	1.00	0.93	0.76	1.00	1.00	0.97	0.79	1.00	1.00	0.98	0.79
	875	Delta T	25	24	23	20	25	25	23	20	24	25	23	20	24	24	23	20	22	23	23	20	21	21	22
KW		1.73	1.77	1.82	1.88	1.86	1.90	1.96	2.02	1.97	2.02	2.08	2.15	2.07	2.12	2.19	2.26	2.16	2.21	2.28	2.35	2.23	2.28	2.36	2.43
AMPS		7.2	7.4	7.6	7.8	7.7	7.9	8.1	8.4	8.3	8.5	8.7	9.0	8.8	9.0	9.3	9.6	9.3	9.5	9.8	10.1	9.8	10.0	10.3	10.7
HI PR		227	244	257	269	254	274	289	301	289	311	329	343	329	354	374	390	371	399	421	439	409	441	465	485
LO PR		114	122	133	141	121	128	140	149	126	134	146	155	132	140	153	163	138	147	160	171	143	152	166	177
MBh		22.8	23.3	24.4	26.0	22.3	22.7	23.8	25.4	21.8	22.2	23.3	24.8	21.2	21.7	22.7	24.2	20.2	20.6	21.6	23.0	18.7	19.1	20.0	21.3
ST		0.94	0.90	0.81	0.66	0.97	0.94	0.84	0.68	0.99	0.96	0.87	0.70	1.00	0.99	0.89	0.72	1.00	1.00	0.93	0.75	1.00	1.00	0.94	0.76
Delta T		26	25	24	21	26	25	24	21	26	25	24	21	25	26	24	21	24	25	24	21	22	23	22	19
KW		1.71	1.74	1.79	1.85	1.83	1.87	1.93	1.99	1.94	1.98	2.05	2.11	2.04	2.08	2.15	2.22	2.12	2.17	2.24	2.31	2.20	2.24	2.32	2.39
AMPS		7.1	7.3	7.5	7.7	7.6	7.8	8.0	8.2	8.2	8.3	8.6	8.9	8.7	8.8	9.1	9.4	9.1	9.3	9.6	9.9	9.6	9.8	10.1	10.5
770	HI PR	222	239	252	263	249	268	283	295	283	305	322	336	323	347	367	383	363	391	413	430	401	432	456	475
	LO PR	112	119	130	139	118	126	137	146	123	131	143	152	129	137	150	160	135	144	157	167	140	149	163	173

* NOTE: Shaded area is AHRI Rating Conditions
 High and low pressures are measured at the liquid and suction access fittings.
 IDB: Entering Indoor Dry Bulb Temperature
 KW = Total system power
 AMPS: Unit amps (comp.+ evaporator + condenser fan motors)

COOLING PERFORMANCE DATA

GPC1330H41AA

EXPANDED PERFORMANCE DATA

EXPANDED PERFORMANCE DATA

MODEL: GPC1330H41A*

Design Subcooling, 12±3 °F @ the liquid access fitting connection AHRI 95 test conditions. Design Superheat 8±3 °F @ the compressor suction access fitting connection.

IDB*	Airflow	Outdoor Ambient Temperature																								
		65					75					85					105					115				
		59	63	67	71	75	59	63	67	71	75	59	63	67	71	75	59	63	67	71	75	59	63	67	71	75
70	MBh	28.2	29.3	32.0	-	27.6	28.6	31.3	-	26.9	27.9	30.6	-	26.3	27.2	29.8	-	24.9	25.8	28.3	-	23.1	23.9	26.2	-	
	ST	0.79	0.66	0.46	-	0.82	0.68	0.47	-	0.84	0.70	0.49	-	0.87	0.72	0.50	-	0.90	0.75	0.52	-	0.91	0.76	0.53	-	
	Delta T	1.7	1.5	1.1	-	1.8	1.5	1.2	-	1.8	1.5	1.2	-	1.8	1.5	1.2	-	1.7	1.5	1.1	-	1.6	1.4	1.1	-	
	KW	2.07	2.11	2.17	-	2.22	2.26	2.33	-	2.35	2.40	2.47	-	2.46	2.52	2.59	-	2.56	2.62	2.70	-	2.65	2.70	2.79	-	
	AMPS	8.8	9.0	9.2	-	9.4	9.6	9.8	-	10.0	10.2	10.5	-	10.6	10.8	11.1	-	11.2	11.4	11.8	-	11.8	12.0	12.4	-	
	HI PR	232	249	263	-	260	280	295	-	296	318	336	-	337	362	382	-	379	407	430	-	418	450	475	-	
1050	LOPR	111	118	129	-	118	125	137	-	122	130	142	-	128	137	149	-	135	143	156	-	139	148	162	-	
	MBh	27.4	28.4	31.1	-	26.8	27.7	30.4	-	26.1	27.1	29.7	-	25.5	26.4	28.9	-	24.2	25.1	27.5	-	22.4	23.2	25.5	-	
	ST	0.75	0.63	0.44	-	0.78	0.65	0.45	-	0.80	0.67	0.46	-	0.83	0.69	0.48	-	0.86	0.72	0.50	-	0.87	0.72	0.50	-	
	Delta T	1.8	1.6	1.2	-	1.8	1.6	1.2	-	1.8	1.6	1.2	-	1.8	1.6	1.2	-	1.8	1.6	1.2	-	1.7	1.5	1.1	-	
	KW	2.05	2.09	2.16	-	2.20	2.25	2.31	-	2.33	2.38	2.45	-	2.45	2.50	2.57	-	2.54	2.60	2.68	-	2.63	2.68	2.77	-	
	AMPS	8.7	8.9	9.1	-	9.3	9.5	9.8	-	10.0	10.2	10.5	-	10.5	10.8	11.1	-	11.1	11.3	11.7	-	11.7	11.9	12.3	-	
920	HI PR	229	247	261	-	257	277	292	-	293	315	332	-	333	359	379	-	375	403	426	-	414	446	471	-	
	LOPR	110	117	128	-	116	124	135	-	121	129	141	-	127	135	148	-	133	142	155	-	138	147	160	-	
	MBh	25.3	26.2	28.7	-	24.7	25.6	28.1	-	24.1	25.0	27.4	-	23.5	24.4	26.7	-	22.3	23.2	25.4	-	20.7	21.5	23.5	-	
	ST	0.73	0.61	0.42	-	0.75	0.63	0.44	-	0.77	0.65	0.45	-	0.80	0.67	0.46	-	0.83	0.69	0.48	-	0.83	0.70	0.48	-	
	Delta T	1.8	1.6	1.2	-	1.9	1.6	1.2	-	1.9	1.6	1.2	-	1.9	1.6	1.2	-	1.8	1.6	1.2	-	1.7	1.5	1.1	-	
	KW	2.01	2.05	2.11	-	2.15	2.19	2.26	-	2.28	2.32	2.39	-	2.39	2.44	2.51	-	2.48	2.53	2.61	-	2.56	2.62	2.70	-	
1180	AMPS	8.5	8.7	8.9	-	9.1	9.3	9.5	-	9.7	9.9	10.2	-	10.3	10.5	10.8	-	10.9	11.1	11.4	-	11.4	11.6	12.0	-	
	HI PR	222	239	253	-	250	269	284	-	284	305	322	-	323	348	367	-	364	391	413	-	402	432	457	-	
	LOPR	107	114	124	-	113	120	131	-	117	125	136	-	123	131	143	-	129	137	150	-	134	142	155	-	
	MBh	28.7	29.5	32.0	34.3	28.0	28.9	31.2	33.5	27.4	28.2	30.5	32.7	26.7	27.5	29.8	31.9	25.4	26.1	28.3	30.3	23.5	24.2	26.2	28.1	
	ST	0.90	0.80	0.61	0.39	0.93	0.83	0.63	0.41	0.95	0.85	0.65	0.42	0.99	0.88	0.67	0.43	1.00	0.91	0.69	0.45	1.00	0.92	0.70	0.45	
	Delta T	2.0	1.9	1.5	1.0	2.0	1.9	1.5	1.1	2.0	1.9	1.5	1.1	2.0	1.9	1.5	1.1	2.0	1.9	1.5	1.1	1.8	1.7	1.4	1.0	
1180	KW	2.08	2.13	2.19	2.25	2.23	2.28	2.35	2.42	2.37	2.42	2.49	2.57	2.48	2.54	2.62	2.70	2.58	2.64	2.72	2.81	2.67	2.73	2.81	2.91	
	AMPS	8.9	9.0	9.3	9.6	9.4	9.6	9.9	10.2	10.1	10.3	10.6	11.0	10.7	10.9	11.2	11.6	11.3	11.5	11.9	12.2	11.9	12.1	12.5	12.9	
	HI PR	234	252	266	277	262	282	298	311	299	321	339	354	340	366	386	403	382	412	435	453	423	455	480	501	
	LOPR	112	120	131	139	119	126	138	147	123	131	143	153	130	138	151	160	136	145	158	168	141	150	163	174	
	MBh	27.9	28.7	31.1	33.3	27.2	28.0	30.3	32.6	26.6	27.4	29.6	31.8	25.9	26.7	28.9	31.0	24.6	25.4	27.4	29.5	22.8	23.5	25.4	27.3	
	ST	0.86	0.77	0.58	0.37	0.89	0.79	0.60	0.39	0.91	0.81	0.62	0.40	0.94	0.84	0.64	0.41	0.98	0.87	0.66	0.42	0.98	0.88	0.67	0.43	
1050	Delta T	2.1	1.9	1.6	1.1	2.1	1.9	1.6	1.1	2.1	2.0	1.6	1.1	2.1	2.0	1.6	1.1	2.1	1.9	1.6	1.1	2.0	1.8	1.5	1.0	
	KW	2.07	2.11	2.17	2.24	2.22	2.26	2.33	2.40	2.35	2.40	2.47	2.55	2.47	2.52	2.60	2.68	2.56	2.62	2.70	2.79	2.65	2.71	2.79	2.88	
	AMPS	8.8	9.0	9.2	9.5	9.4	9.6	9.8	10.1	10.0	10.3	10.5	10.9	10.6	10.8	11.2	11.5	11.2	11.4	11.8	12.2	11.8	12.0	12.4	12.8	
	HI PR	232	249	263	275	260	280	295	308	296	318	336	350	337	362	383	399	379	408	430	449	418	450	475	496	
	LOPR	111	118	129	138	118	125	137	145	122	130	142	151	128	137	149	159	135	143	156	166	139	148	162	172	
	MBh	25.7	26.5	28.7	30.8	25.1	25.9	28.0	30.0	24.5	25.2	27.3	29.3	23.9	24.6	26.7	28.6	22.7	23.4	25.3	27.2	21.1	21.7	23.5	25.2	
920	ST	0.83	0.74	0.56	0.36	0.86	0.77	0.58	0.37	0.88	0.79	0.59	0.38	0.91	0.81	0.61	0.39	0.94	0.84	0.64	0.41	0.95	0.85	0.64	0.41	
	Delta T	2.1	2.0	1.6	1.1	2.1	2.0	1.6	1.1	2.2	2.0	1.6	1.1	2.2	2.0	1.6	1.1	2.1	2.0	1.6	1.1	2.0	1.8	1.5	1.0	
	KW	2.02	2.06	2.12	2.19	2.17	2.21	2.28	2.35	2.29	2.34	2.41	2.49	2.41	2.46	2.53	2.61	2.50	2.56	2.64	2.72	2.59	2.64	2.72	2.81	
	AMPS	8.6	8.8	9.0	9.3	9.2	9.3	9.6	9.9	9.8	10.0	10.3	10.6	10.4	10.6	10.9	11.2	10.9	11.2	11.5	11.9	11.5	11.7	12.1	12.5	
	HI PR	225	242	255	266	252	271	286	299	287	309	326	340	327	351	371	387	367	395	417	435	406	437	461	481	
	LOPR	108	115	125	134	114	121	132	141	119	126	138	147	125	132	145	154	130	139	152	161	135	144	157	167	

* IDB: Entering Indoor Dry Bulb Temperature

High and low pressures are measured at the liquid and suction access fittings.

NOTE: Shaded area is ACCA (TVA) conditions

COOLING PERFORMANCE DATA

GPC1330H41AA

EXPANDED PERFORMANCE DATA

COOLING OPERATION

MODEL: GPC1330H41A*

Design Subcooling, 12±3 °F @ the liquid access fitting connection AHRI 95 test conditions. Design Superheat 8±3 °F @ the compressor suction access fitting connection.

IDB*	Airflow	Outdoor Ambient Temperature										Entering Indoor Wet Bulb Temperature																																					
		65					75					85					95					105					115																						
		59	63	67	71	75	59	63	67	71	75	59	63	67	71	75	59	63	67	71	75	59	63	67	71	75	59	63	67	71	75																		
80	MBh	29.2	29.8	31.9	34.1	38.5	29.2	31.1	33.3	37.9	28.5	30.4	32.5	37.2	27.8	29.7	31.7	25.8	26.4	28.2	30.1	23.9	24.4	26.1	27.9	29.2	29.8	31.9	34.1	38.5	29.2	31.1	33.3	37.9	28.5	30.4	32.5	37.2	27.8	29.7	31.7	25.8	26.4	28.2	30.1	23.9	24.4	26.1	27.9
	ST	1.00	0.92	0.75	0.56	1.00	0.96	0.78	0.58	1.00	1.00	0.80	0.60	1.00	1.00	0.83	0.62	1.00	1.00	0.86	0.64	1.00	1.00	0.86	0.65	1.00	0.92	0.75	0.56	1.00	0.96	0.78	0.58	1.00	1.00	0.80	0.60	1.00	1.00	0.83	0.62	1.00	1.00	0.86	0.64	1.00	1.00	0.86	0.65
	Delta T	2.3	2.1	1.9	1.5	2.2	2.2	2.2	1.5	1.5	2.2	2.2	1.9	1.5	2.1	2.2	1.9	1.5	2.1	2.2	1.9	1.5	1.9	1.9	1.4	2.3	2.1	1.9	1.5	2.2	2.2	2.2	1.5	1.5	2.2	2.2	1.9	1.5	2.1	2.2	1.9	1.5	1.9	1.9	1.4	1.4			
	KW	2.10	2.14	2.21	2.27	2.25	2.30	2.37	2.44	2.39	2.44	2.51	2.59	2.50	2.56	2.64	2.72	2.60	2.66	2.74	2.83	2.69	2.75	2.84	2.93	2.10	2.14	2.21	2.27	2.25	2.30	2.37	2.44	2.39	2.44	2.51	2.59	2.50	2.56	2.64	2.72	2.60	2.66	2.74	2.83	2.69	2.75	2.84	2.93
	AMPS	8.9	9.1	9.3	9.6	9.5	9.7	10.0	10.3	10.2	10.4	10.7	11.0	10.8	11.0	11.3	11.7	11.4	11.6	12.0	12.3	12.0	12.2	12.6	13.0	8.9	9.1	9.3	9.6	9.5	9.7	10.0	10.3	10.2	10.4	10.7	11.0	10.8	11.0	11.3	11.7	11.4	11.6	12.0	12.3	12.0	12.2	12.6	13.0
	HI PR	236	254	269	280	265	285	301	314	302	324	343	357	343	370	390	407	386	416	439	458	427	459	485	506	236	254	269	280	265	285	301	314	302	324	343	357	343	370	390	407	386	416	439	458	427	459	485	506
	LO PR	114	121	132	140	120	128	139	148	125	133	145	154	131	139	152	162	137	146	159	170	142	151	165	176	114	121	132	140	120	128	139	148	125	133	145	154	131	139	152	162	137	146	159	170	142	151	165	176
	MBh	28.4	29.0	31.0	33.1	27.7	28.3	30.2	32.3	27.0	27.6	29.5	31.6	26.4	27.0	28.8	30.8	25.1	25.6	27.4	29.2	23.2	23.7	25.3	27.1	28.4	29.0	31.0	33.1	27.7	28.3	30.2	32.3	27.0	27.6	29.5	31.6	26.4	27.0	28.8	30.8	25.1	25.6	27.4	29.2	23.2	23.7	25.3	27.1
	ST	0.94	0.88	0.72	0.54	0.97	0.91	0.74	0.56	1.00	0.94	0.76	0.57	1.00	0.97	0.79	0.59	1.00	1.00	0.82	0.61	1.00	1.00	0.82	0.62	0.94	0.88	0.72	0.54	0.97	0.91	0.74	0.56	1.00	0.94	0.76	0.57	1.00	0.97	0.79	0.59	1.00	1.00	0.82	0.61	1.00	1.00	0.82	0.62
	Delta T	2.3	2.2	1.9	1.6	2.4	2.3	2.0	1.6	2.4	2.3	2.0	1.6	2.3	2.3	2.0	1.6	2.2	2.2	2.0	1.6	2.0	2.1	1.8	1.5	2.3	2.2	1.9	1.6	2.4	2.3	2.0	1.6	2.4	2.3	2.0	1.6	2.3	2.3	2.0	1.6	2.2	2.2	2.0	1.6	2.0	2.1	1.8	1.5
KW	2.08	2.13	2.19	2.25	2.23	2.28	2.35	2.42	2.37	2.42	2.49	2.57	2.48	2.54	2.62	2.70	2.58	2.64	2.72	2.81	2.67	2.73	2.81	2.91	2.08	2.13	2.19	2.25	2.23	2.28	2.35	2.42	2.37	2.42	2.49	2.57	2.48	2.54	2.62	2.70	2.58	2.64	2.72	2.81	2.67	2.73	2.81	2.91	
AMPS	8.9	9.0	9.3	9.6	9.4	9.6	9.9	10.2	10.1	10.3	10.6	11.0	10.7	10.9	11.2	11.6	11.3	11.5	11.9	12.3	11.9	12.1	12.5	12.9	8.9	9.0	9.3	9.6	9.4	9.6	9.9	10.2	10.1	10.3	10.6	11.0	10.7	10.9	11.2	11.6	11.3	11.5	11.9	12.3	11.9	12.1	12.5	12.9	
HI PR	234	252	266	277	263	282	298	311	299	321	339	354	340	366	386	403	383	412	435	453	423	455	480	501	234	252	266	277	263	282	298	311	299	321	339	354	340	366	386	403	383	412	435	453	423	455	480	501	
LO PR	112	120	131	139	119	126	138	147	123	131	143	153	130	138	151	160	136	145	158	168	141	150	163	174	112	120	131	139	119	126	138	147	123	131	143	153	130	138	151	160	136	145	158	168	141	150	163	174	
920	MBh	26.2	26.7	28.6	30.5	25.6	26.1	27.9	29.8	25.0	25.5	27.2	29.1	24.3	24.9	26.6	28.4	23.1	23.6	25.3	27.0	21.4	21.9	23.4	25.0	26.2	26.7	28.6	30.5	25.6	26.1	27.9	29.8	25.0	25.5	27.2	29.1	24.3	24.9	26.6	28.4	23.1	23.6	25.3	27.0	21.4	21.9	23.4	25.0
	ST	0.91	0.85	0.69	0.52	0.94	0.88	0.72	0.54	0.96	0.90	0.74	0.55	0.99	0.93	0.76	0.57	1.03	0.97	0.79	0.59	1.04	0.98	0.79	0.59	0.91	0.85	0.69	0.52	0.94	0.88	0.72	0.54	0.96	0.90	0.74	0.55	0.99	0.93	0.76	0.57	1.03	0.97	0.79	0.59	1.04	0.98	0.79	0.59
	Delta T	2.4	2.3	2.0	1.6	2.4	2.3	2.0	1.6	2.4	2.3	2.0	1.6	2.4	2.3	2.0	1.6	2.4	2.3	2.0	1.6	2.2	2.1	1.9	1.5	2.4	2.3	2.0	1.6	2.4	2.3	2.0	1.6	2.4	2.3	2.0	1.6	2.4	2.3	2.0	1.6	2.2	2.1	1.9	1.5				
	KW	2.04	2.08	2.14	2.20	2.18	2.23	2.29	2.37	2.31	2.36	2.43	2.51	2.43	2.48	2.55	2.63	2.52	2.58	2.66	2.74	2.61	2.66	2.75	2.83	2.04	2.08	2.14	2.20	2.18	2.23	2.29	2.37	2.31	2.36	2.43	2.51	2.43	2.48	2.55	2.63	2.52	2.58	2.66	2.74	2.61	2.66	2.75	2.83
	AMPS	8.7	8.8	9.1	9.3	9.2	9.4	9.7	10.0	9.9	10.1	10.4	10.7	10.5	10.7	11.0	11.3	11.0	11.3	11.6	12.0	11.6	11.8	12.2	12.6	8.7	8.8	9.1	9.3	9.2	9.4	9.7	10.0	9.9	10.1	10.4	10.7	10.5	10.7	11.0	11.3	11.0	11.3	11.6	12.0	11.6	11.8	12.2	12.6
	HI PR	227	244	258	269	255	274	289	302	290	312	329	343	330	355	375	391	371	399	422	440	410	441	466	486	227	244	258	269	255	274	289	302	290	312	329	343	330	355	375	391	371	399	422	440	410	441	466	486
	LO PR	109	116	127	135	115	123	134	143	120	127	139	148	126	134	146	156	132	140	153	163	136	145	158	169	109	116	127	135	115	123	134	143	120	127	139	148	126	134	146	156	132	140	153	163	136	145	158	169
	MBh	29.7	30.3	31.7	33.9	29.0	29.6	31.0	33.1	28.3	28.9	30.3	32.3	27.6	28.2	29.5	31.5	26.3	26.8	28.0	29.9	24.3	24.8	26.0	27.7	29.7	30.3	31.7	33.9	29.0	29.6	31.0	33.1	28.3	28.9	30.3	32.3	27.6	28.2	29.5	31.5	26.3	26.8	28.0	29.9	24.3	24.8	26.0	27.7
	ST	1.00	1.00	0.90	0.73	1.00	1.00	0.93	0.76	1.00	1.00	0.96	0.78	1.00	1.00	0.99	0.80	1.00	1.00	0.98	0.83	1.00	1.00	0.84	1.00	1.00	0.90	0.73	1.00	1.00	0.93	0.76	1.00	1.00	0.96	0.78	1.00	1.00	0.99	0.80	1.00	1.00	0.98	0.83	1.00	1.00	0.84		
	Delta T	2.3	2.4	2.2	1.9	2.3	2.3	2.3	1.9	2.2	2.3	2.3	2.0	2.2	2.2	2.3	2.0	2.2	2.2	2.3	2.0	2.1	2.2	2.0	1.8	2.3	2.4	2.2	1.9	2.3	2.3	2.3	1.9	2.2	2.3	2.3	2.0	2.2	2.2	2.3	2.0	2.2	2.2	2.3	2.0	2.1	2.2	2.0	1.8
KW	2.12	2.16	2.22	2.29	2.27	2.32	2.39	2.46	2.40	2.45	2.53	2.61	2.52	2.58	2.66	2.74	2.63	2.68	2.77	2.86	2.71	2.77	2.86	2.95	2.12	2.16	2.22	2.29	2.27	2.32	2.39	2.46	2.40	2.45	2.53	2.61	2.52	2.58	2.66	2.74	2.63	2.68	2.77	2.86	2.71	2.77	2.86	2.95	
AMPS	9.0	9.2	9.4	9.7	9.6	9.8	10.1	10.4	10.3	10.5	10.8	11.1	10.9	11.1	11.4	11.8	11.5	11.7	12.1	12.4	12.1	12.3	12.7	13.1	9.0	9.2	9.4	9.7	9.6	9.8	10.1	10.4	10.3	10.5	10.8	11.1	10.9	11.1	11.4	11.8	11.5	11.7	12.1	12.4	12.1	12.3	12.7	13.1	
HI PR	239	257	271	283	268	288	304	317	305	328	346	361	347	373	394	411	390	420	443	463	431	464	490	511	239	257	271	283	268	288	304	317	305	328	346	361	347	373	394	411	390	420	443	463	431	464	490	511	
LO PR	115	122	133	142	121	129	141	150	126	134	146	156	132	141	154	164	139	147	161	171	143	153																											

COOLING PERFORMANCE DATA

GPC1336H41AA

MODEL: GPC1336H41A* EXPANDED PERFORMANCE DATA COOLING OPERATION

Design Subcooling, 1.2±3 °F @ the liquid access fitting connection AHRI 95 test conditions. Design Superheat 8±3 °F @ the compressor suction access fitting connection.

IDB*	Airflow	Outdoor Ambient Temperature																								
		65					75					85					105					115				
		59	63	67	71	75	59	63	67	71	75	59	63	67	71	75	59	63	67	71	75	59	63	67	71	75
70	1350	MBh	34.5	35.8	39.2	-	33.7	34.9	38.3	-	32.9	34.1	37.3	-	32.1	33.3	36.4	-	30.5	31.6	34.6	-	28.2	29.3	32.1	-
		ST	0.74	0.62	0.43	-	0.77	0.64	0.45	-	0.79	0.66	0.46	-	0.82	0.68	0.47	-	0.85	0.71	0.49	-	0.85	0.71	0.49	-
		Delta T	17	15	11	-	18	15	12	-	18	15	12	-	18	15	12	-	18	15	12	-	16	14	11	-
		KW	2.53	2.59	2.66	-	2.72	2.78	2.86	-	2.89	2.95	3.04	-	3.03	3.10	3.20	-	3.16	3.23	3.33	-	3.26	3.34	3.44	-
		AMPS	10.9	11.1	11.4	-	11.6	11.9	12.2	-	12.5	12.7	13.1	-	13.2	13.5	13.9	-	13.9	14.2	14.7	-	14.7	15.0	15.4	-
	1200	HI PR	241	260	274	-	271	291	308	-	308	331	350	-	351	377	399	-	395	425	448	-	436	469	495	-
		LO PR	108	115	125	-	114	121	132	-	118	126	137	-	124	132	144	-	130	139	151	-	135	143	156	-
		MBh	33.5	34.7	38.0	-	32.7	33.9	37.1	-	31.9	33.1	36.3	-	31.2	32.3	35.4	-	29.6	30.7	33.6	-	27.4	28.4	31.1	-
		ST	0.71	0.59	0.41	-	0.73	0.61	0.43	-	0.75	0.63	0.44	-	0.78	0.65	0.45	-	0.81	0.67	0.47	-	0.81	0.68	0.47	-
		Delta T	18	16	12	-	18	16	12	-	18	16	12	-	19	16	12	-	18	16	12	-	17	15	11	-
1050	KW	2.52	2.57	2.64	-	2.70	2.76	2.84	-	2.86	2.93	3.02	-	3.01	3.07	3.17	-	3.13	3.20	3.30	-	3.24	3.31	3.42	-	
	AMPS	10.8	11.0	11.3	-	11.6	11.8	12.1	-	12.4	12.6	13.0	-	13.1	13.4	13.8	-	13.8	14.1	14.5	-	14.5	14.9	15.3	-	
	HI PR	239	257	271	-	268	288	305	-	305	328	346	-	347	374	395	-	391	420	444	-	432	464	490	-	
	LO PR	107	114	124	-	113	120	131	-	117	125	136	-	123	131	143	-	129	137	150	-	133	142	155	-	
	MBh	30.9	32.0	35.1	-	30.2	31.3	34.3	-	29.5	30.5	33.5	-	28.8	29.8	32.7	-	27.3	28.3	31.0	-	25.3	26.2	28.7	-	
75	1350	ST	0.88	0.76	0.57	0.37	0.88	0.78	0.59	0.38	0.90	0.80	0.61	0.39	0.93	0.83	0.63	0.40	0.96	0.86	0.65	0.42	0.97	0.87	0.66	0.42
		Delta T	20	19	15	11	20	19	15	11	21	19	15	11	21	19	15	11	20	19	15	11	19	17	14	10
		KW	2.55	2.61	2.69	2.77	2.74	2.80	2.89	2.98	2.91	2.97	3.07	3.16	3.06	3.12	3.22	3.33	3.18	3.25	3.36	3.47	3.29	3.36	3.47	3.59
		AMPS	11.0	11.2	11.5	11.9	11.7	12.0	12.3	12.7	12.6	12.8	13.2	13.6	13.3	13.6	14.0	14.4	14.1	14.4	14.8	15.3	14.8	15.1	15.5	16.1
		HI PR	244	262	277	289	274	294	311	324	311	335	353	369	354	381	403	420	399	429	453	472	440	474	500	522
	1200	LO PR	109	116	126	135	115	122	134	142	120	127	139	148	126	134	146	155	132	140	153	163	136	145	158	168
		MBh	34.1	35.1	38.0	40.7	33.3	34.2	37.1	39.8	32.5	33.4	36.2	38.8	31.7	32.6	35.3	37.9	30.1	31.0	33.5	36.0	27.9	28.7	31.1	33.3
		ST	0.81	0.72	0.55	0.35	0.84	0.75	0.57	0.36	0.86	0.77	0.58	0.37	0.88	0.79	0.60	0.38	0.92	0.82	0.62	0.40	0.93	0.83	0.63	0.40
		Delta T	21	19	16	11	21	20	16	11	21	20	16	11	21	20	16	11	21	19	16	11	20	18	15	10
		KW	2.53	2.59	2.67	2.75	2.72	2.78	2.87	2.96	2.89	2.95	3.04	3.14	3.03	3.10	3.20	3.30	3.16	3.23	3.33	3.44	3.27	3.34	3.44	3.56
1050	AMPS	10.9	11.1	11.4	11.8	11.6	11.9	12.2	12.6	12.5	12.7	13.1	13.5	13.2	13.5	13.9	14.3	13.9	14.2	14.7	15.1	14.7	15.0	15.4	15.9	
	HI PR	241	260	274	286	271	291	308	321	308	331	350	365	351	377	399	416	395	425	448	468	436	469	495	517	
	LO PR	108	115	125	133	114	121	132	141	118	126	137	146	124	132	144	154	130	139	151	161	135	143	157	167	
	MBh	31.4	32.4	35.0	37.6	30.7	31.6	34.2	36.7	30.0	30.9	33.4	35.8	29.2	30.1	32.6	35.0	27.8	28.6	31.0	33.2	25.7	26.5	28.7	30.8	
	ST	0.78	0.69	0.53	0.34	0.81	0.72	0.55	0.35	0.83	0.74	0.56	0.36	0.85	0.76	0.58	0.37	0.88	0.79	0.60	0.39	0.89	0.80	0.60	0.39	
1050	Delta T	21	20	16	11	22	20	16	11	22	20	16	11	22	20	16	11	22	20	16	11	20	19	15	10	
	KW	2.48	2.53	2.60	2.68	2.66	2.71	2.80	2.89	2.82	2.88	2.97	3.06	2.96	3.02	3.12	3.22	3.08	3.15	3.25	3.35	3.19	3.25	3.36	3.47	
	AMPS	10.7	10.9	11.2	11.5	11.4	11.6	11.9	12.3	12.2	12.4	12.8	13.2	12.9	13.2	13.5	14.0	13.6	13.9	14.3	14.8	14.3	14.6	15.0	15.5	
	HI PR	234	252	266	277	263	283	299	311	299	321	339	354	340	366	387	403	383	412	435	454	423	455	481	501	
	LO PR	105	111	121	129	110	118	128	137	115	122	133	142	121	128	140	149	126	134	147	156	131	139	152	162	

* IDB: Entering Indoor Dry Bulb Temperature

High and low pressures are measured at the liquid and suction access fittings.

NOTE: Shaded area is ACCA (TVA) conditions

COOLING PERFORMANCE DATA

GPC1336H41AA

MODEL: GPC1336H41A* EXPANDED PERFORMANCE DATA COOLING OPERATION

Design Subcooling, 12±3 °F @ the liquid access fitting connection AHRI 95 test conditions. Design Superheat 8±3 °F @ the compressor suction access fitting connection.

IDB*	Airflow	Outdoor Ambient Temperature																								
		65				75				85				105				115								
		59	63	67	71	59	63	67	71	59	63	67	71	59	63	67	71	59	63	67	71					
80	1350	MBh	35.7	36.5	39.0	41.7	34.9	35.6	38.1	40.7	34.0	34.8	37.2	39.7	33.2	33.9	36.3	38.8	31.5	32.2	34.4	36.8	29.2	29.9	31.9	34.1
		ST	0.93	0.87	0.71	0.53	0.96	0.90	0.73	0.55	1.00	0.92	0.75	0.56	1.00	0.95	0.78	0.58	1.00	1.00	0.81	0.60	1.00	1.00	0.81	0.61
		Delta T	23	22	19	15	23	22	19	15	23	22	19	15	23	22	19	15	21	21	19	15	20	20	18	14
		KW	2.57	2.63	2.71	2.79	2.77	2.82	2.91	3.00	2.93	3.00	3.09	3.19	3.08	3.15	3.25	3.36	3.21	3.28	3.39	3.50	3.32	3.39	3.50	3.62
		AMPS	11.1	11.3	11.6	12.0	11.8	12.1	12.4	12.8	12.7	12.9	13.3	13.7	13.4	13.7	14.1	14.6	14.2	14.5	14.9	15.4	14.9	15.2	15.7	16.2
		HI PR	246	265	280	292	276	297	314	327	314	338	357	372	358	385	407	424	403	433	458	477	445	479	505	527
		LO PR	110	117	128	136	116	124	135	144	121	128	140	149	127	135	147	157	133	141	154	164	137	146	160	170
		MBh	34.7	35.4	37.8	40.5	33.9	34.6	37.0	39.5	33.0	33.8	36.1	38.6	32.2	32.9	35.2	37.6	30.6	31.3	33.4	35.7	28.4	29.0	31.0	33.1
		ST	0.88	0.83	0.67	0.50	0.92	0.86	0.70	0.52	0.94	0.88	0.72	0.54	0.97	0.91	0.74	0.55	1.00	0.94	0.77	0.57	1.00	0.95	0.77	0.58
		Delta T	23	22	20	16	24	23	20	16	24	23	20	16	24	23	20	16	24	23	20	16	22	21	18	15
KW	2.55	2.61	2.69	2.77	2.74	2.80	2.89	2.98	2.91	2.97	3.07	3.17	3.06	3.12	3.22	3.33	3.18	3.25	3.36	3.47	3.29	3.36	3.47	3.59		
AMPS	11.0	11.2	11.5	11.9	11.7	12.0	12.3	12.7	12.6	12.8	13.2	13.6	13.3	13.6	14.0	14.4	14.1	14.4	14.8	15.3	14.8	15.1	15.5	16.1		
HI PR	244	262	277	289	274	294	311	324	311	335	354	369	354	381	403	420	399	429	453	472	440	474	500	522		
LO PR	109	116	126	135	115	122	134	142	120	127	139	148	126	134	146	155	132	140	153	163	136	145	158	168		
MBh	32.0	32.7	34.9	37.3	31.2	31.9	34.1	36.5	30.5	31.2	33.3	35.6	29.8	30.4	32.5	34.7	28.3	28.9	30.9	33.0	26.2	26.8	28.6	30.6		
ST	0.85	0.80	0.65	0.49	0.88	0.83	0.67	0.50	0.91	0.85	0.69	0.52	0.93	0.88	0.71	0.53	0.97	0.91	0.74	0.55	0.98	0.92	0.75	0.56		
Delta T	24	23	20	16	24	23	20	16	24	23	20	16	24	23	20	16	24	23	20	16	22	21	19	15		
KW	2.50	2.55	2.62	2.70	2.68	2.73	2.82	2.91	2.84	2.90	2.99	3.09	2.98	3.05	3.15	3.25	3.11	3.17	3.28	3.38	3.21	3.28	3.39	3.50		
AMPS	10.7	11.0	11.3	11.6	11.5	11.7	12.0	12.4	12.3	12.5	12.9	13.3	13.0	13.3	13.7	14.1	13.7	14.0	14.4	14.9	14.4	14.7	15.2	15.7		
HI PR	236	254	269	280	265	286	302	314	302	325	343	358	344	370	391	407	387	416	439	458	427	460	485	506		
LO PR	106	112	123	131	112	119	130	138	116	123	135	143	122	130	141	151	128	136	148	158	132	140	153	163		
85	1350	MBh	36.3	37.0	38.8	41.4	35.5	36.2	37.9	40.4	34.6	35.3	37.0	39.4	33.8	34.4	36.1	38.5	32.1	32.7	34.3	36.6	29.7	30.3	31.7	33.9
		ST	0.97	0.94	0.85	0.69	1.00	0.97	0.88	0.71	1.00	1.00	0.90	0.73	1.00	1.00	0.93	0.75	1.00	1.00	0.96	0.78	1.00	1.00	0.97	0.79
		Delta T	24	24	22	19	24	24	23	20	24	24	23	20	23	23	23	20	22	22	22	19	20	21	21	18
		KW	2.59	2.65	2.73	2.81	2.79	2.85	2.93	3.03	2.96	3.02	3.12	3.22	3.11	3.18	3.28	3.38	3.24	3.31	3.41	3.53	3.35	3.42	3.53	3.65
		AMPS	11.2	11.4	11.7	12.1	11.9	12.2	12.5	12.9	12.8	13.0	13.4	13.9	13.5	13.8	14.2	14.7	14.3	14.6	15.0	15.5	15.0	15.3	15.8	16.3
		HI PR	249	268	283	295	279	300	317	331	317	342	361	376	361	389	411	428	407	438	462	482	449	483	511	533
		LO PR	111	118	129	137	117	125	136	145	122	130	142	151	128	136	149	158	134	143	156	166	139	148	161	172
		MBh	35.3	35.9	37.7	40.2	34.4	35.1	36.8	39.2	33.6	34.3	35.9	38.3	32.8	33.4	35.0	37.4	31.2	31.8	33.3	35.5	28.9	29.4	30.8	32.9
		ST	0.93	0.89	0.81	0.65	0.96	0.93	0.84	0.68	0.98	0.95	0.86	0.70	1.00	0.98	0.89	0.72	1.00	1.00	0.92	0.75	1.00	1.00	0.93	0.75
		Delta T	25	25	23	20	25	25	24	20	25	25	24	20	25	25	24	21	24	24	24	23	22	23	22	19
KW	2.57	2.63	2.71	2.79	2.77	2.82	2.91	3.00	2.93	3.00	3.09	3.19	3.08	3.15	3.25	3.36	3.21	3.28	3.39	3.50	3.32	3.39	3.50	3.62		
AMPS	11.1	11.3	11.6	12.0	11.8	12.1	12.4	12.8	12.7	12.9	13.3	13.7	13.4	13.7	14.1	14.6	14.2	14.5	14.9	15.4	14.9	15.2	15.7	16.2		
HI PR	246	265	280	292	276	297	314	327	314	338	357	372	358	385	407	424	403	433	458	477	445	479	505	527		
LO PR	110	117	128	136	116	124	135	144	121	128	140	149	127	135	147	157	133	141	154	164	137	146	160	170		
MBh	32.6	33.2	34.8	37.1	31.8	32.4	33.9	36.2	31.0	31.6	33.1	35.4	30.3	30.9	32.3	34.5	28.8	29.3	30.7	32.8	26.6	27.2	28.4	30.3		
ST	0.89	0.86	0.78	0.63	0.93	0.89	0.81	0.65	0.95	0.92	0.83	0.67	0.98	0.95	0.85	0.69	1.00	0.98	0.89	0.72	1.00	0.99	0.89	0.72		
Delta T	25	25	24	20	26	25	24	21	26	25	24	21	26	26	24	21	25	25	24	21	23	24	22	19		
KW	2.51	2.57	2.64	2.73	2.70	2.76	2.84	2.93	2.86	2.92	3.02	3.11	3.01	3.07	3.17	3.27	3.13	3.20	3.30	3.41	3.24	3.31	3.42	3.53		
AMPS	10.8	11.0	11.3	11.7	11.5	11.8	12.1	12.5	12.4	12.6	13.0	13.4	13.1	13.4	13.8	14.2	13.8	14.1	14.5	15.0	14.5	14.8	15.3	15.8		
HI PR	239	257	271	283	268	288	305	318	305	328	346	361	347	374	394	411	391	420	444	463	431	464	490	511		
LO PR	107	113	124	132	113	120	131	139	117	125	136	145	123	131	143	152	129	137	150	159	133	142	155	165		

* NOTE: Shaded areas is A-HRI Rating Conditions IDB: Entering Indoor Dry Bulb Temperature KW = Total system power
High and low pressures are measured at the liquid and suction access fittings. AMPS: Unit amps (comp.+ evaporator + condenser fan motors)

COOLING PERFORMANCE DATA

GPC1342H41AA

MODEL: GPC1342H41A* EXPANDED PERFORMANCE DATA COOLING OPERATION

Design Subcooling, 1.2±3 °F @ the liquid access fitting connection AHRI 95 test conditions. Design Superheat 8±3 °F @ the compressor suction access fitting connection.

IDB*	Airflow	Outdoor Ambient Temperature																													
		65					75					85					95					105					115				
		59	63	67	71	75	59	63	67	71	75	59	63	67	71	75	59	63	67	71	75	59	63	67	71	75	59	63	67	71	75
70	1580	MBh	40.2	41.6	45.6	-	39.2	40.7	44.6	-	38.3	39.7	43.5	-	37.4	38.7	42.4	-	35.5	36.8	40.3	-	32.9	34.1	37.3	-					
		ST	0.77	0.65	0.45	-	0.80	0.67	0.46	-	0.82	0.69	0.48	-	0.85	0.71	0.49	-	0.88	0.74	0.51	-	0.89	0.74	0.51	-					
		Delta T	18	16	12	-	18	16	12	-	18	16	12	-	18	16	12	-	18	16	12	-	17	15	11	-					
		KW	2.77	2.83	2.91	-	2.97	3.03	3.12	-	3.14	3.20	3.30	-	3.29	3.36	3.46	-	3.42	3.49	3.60	-	3.53	3.60	3.72	-					
		AMPS	12.3	12.5	12.9	-	13.1	13.4	13.7	-	14.0	14.3	14.7	-	14.8	15.1	15.6	-	15.6	16.0	16.4	-	16.4	16.8	17.3	-					
	1410	HI PR	225	242	256	-	252	272	287	-	287	309	326	-	327	352	372	-	368	396	418	-	406	437	462	-					
		LO PR	110	117	128	-	117	124	135	-	121	129	141	-	127	135	148	-	133	142	155	-	138	147	160	-					
		MBh	39.0	40.4	44.3	-	38.1	39.5	43.3	-	37.2	38.5	42.2	-	36.3	37.6	41.2	-	34.5	35.7	39.1	-	31.9	33.1	36.3	-					
		ST	0.74	0.62	0.43	-	0.77	0.64	0.44	-	0.78	0.66	0.45	-	0.81	0.68	0.47	-	0.84	0.70	0.49	-	0.85	0.71	0.49	-					
		Delta T	19	16	12	-	19	16	12	-	19	16	12	-	19	17	13	-	19	16	12	-	18	15	12	-					
1240	KW	2.75	2.81	2.89	-	2.95	3.00	3.09	-	3.12	3.18	3.27	-	3.27	3.33	3.43	-	3.39	3.46	3.57	-	3.50	3.58	3.69	-						
	AMPS	12.2	12.5	12.8	-	13.0	13.3	13.6	-	13.9	14.2	14.6	-	14.7	15.0	15.4	-	15.5	15.8	16.3	-	16.3	16.6	17.1	-						
	HI PR	223	240	253	-	250	269	284	-	284	306	323	-	324	348	368	-	364	392	414	-	402	433	457	-						
	LO PR	109	116	127	-	115	123	134	-	120	128	139	-	126	134	146	-	132	140	153	-	137	145	159	-						
	MBh	36.0	37.3	40.9	-	35.2	36.4	39.9	-	34.3	35.6	39.0	-	33.5	34.7	38.0	-	31.8	33.0	36.1	-	29.5	30.5	33.5	-						
75	1580	ST	0.71	0.59	0.41	-	0.74	0.62	0.43	-	0.76	0.63	0.44	-	0.78	0.65	0.45	-	0.81	0.68	0.47	-	0.82	0.68	0.47	-					
		Delta T	19	16	12	-	19	17	13	-	19	17	13	-	19	17	13	-	19	17	13	-	18	15	12	-					
		KW	2.69	2.74	2.82	-	2.88	2.94	3.02	-	3.04	3.11	3.20	-	3.19	3.25	3.35	-	3.31	3.38	3.49	-	3.42	3.49	3.60	-					
		AMPS	12.0	12.2	12.5	-	12.7	13.0	13.3	-	13.6	13.9	14.3	-	14.4	14.7	15.1	-	15.2	15.5	15.9	-	15.9	16.2	16.7	-					
		HI PR	216	233	246	-	242	261	275	-	276	297	313	-	314	338	357	-	353	380	401	-	390	420	444	-					
	1410	LO PR	106	113	123	-	112	119	130	-	116	124	135	-	122	130	142	-	128	136	149	-	132	141	154	-					
		MBh	40.9	42.1	45.5	48.9	39.9	41.1	44.5	47.7	39.0	40.1	43.4	46.6	38.0	39.1	42.4	45.5	36.1	37.2	40.2	43.2	33.4	34.4	37.3	40.0					
		ST	0.88	0.79	0.60	0.38	0.91	0.82	0.62	0.40	0.94	0.84	0.63	0.41	0.97	0.86	0.65	0.42	1.00	0.90	0.68	0.44	1.00	0.90	0.68	0.44					
		Delta T	21	19	16	11	21	20	16	11	21	20	16	11	21	20	16	11	21	19	16	11	19	18	15	10					
		KW	2.79	2.85	2.93	3.02	2.99	3.05	3.14	3.23	3.16	3.23	3.32	3.43	3.32	3.38	3.49	3.60	3.45	3.52	3.63	3.74	3.56	3.63	3.75	3.87					
75	1580	AMPS	12.4	12.6	13.0	13.4	13.2	13.5	13.8	14.3	14.1	14.4	14.8	15.3	15.0	15.3	15.7	16.2	15.8	16.1	16.5	17.1	16.6	16.9	17.4	18.0					
		HI PR	227	245	258	269	255	274	290	302	290	312	330	344	330	355	375	392	372	400	422	440	411	442	467	487					
		LO PR	111	119	129	138	118	125	137	146	122	130	142	151	128	137	149	159	135	143	156	167	139	148	162	172					
		MBh	39.7	40.8	44.2	47.4	38.7	39.9	43.2	46.3	37.8	38.9	42.2	45.2	36.9	38.0	41.1	44.1	35.1	36.1	39.1	41.9	32.5	33.4	36.2	38.8					
		ST	0.84	0.75	0.57	0.37	0.87	0.78	0.59	0.38	0.89	0.80	0.60	0.39	0.92	0.82	0.62	0.40	0.96	0.85	0.65	0.42	0.96	0.86	0.65	0.42					
	1410	Delta T	22	20	16	11	22	20	17	11	22	20	17	11	22	20	17	12	22	20	16	11	20	19	15	11					
		KW	2.77	2.83	2.91	2.99	2.97	3.03	3.12	3.21	3.14	3.20	3.30	3.40	3.29	3.36	3.46	3.57	3.42	3.49	3.60	3.71	3.53	3.60	3.72	3.84					
		AMPS	12.3	12.6	12.9	13.3	13.1	13.4	13.7	14.2	14.0	14.3	14.7	15.2	14.8	15.1	15.6	16.1	15.6	16.0	16.4	17.0	16.4	16.8	17.3	17.8					
		HI PR	225	242	256	267	252	272	287	299	287	309	326	340	327	352	372	388	368	396	418	436	407	437	462	482					
		LO PR	110	117	128	136	117	124	135	144	121	129	141	151	127	135	148	157	133	142	155	165	138	147	160	171					
1240	MBh	36.6	37.7	40.8	43.8	35.8	36.8	39.9	42.8	34.9	35.9	38.9	41.8	34.1	35.1	38.0	40.7	32.4	33.3	36.1	38.7	30.0	30.9	33.4	35.8						
	ST	0.81	0.72	0.55	0.35	0.84	0.75	0.57	0.37	0.86	0.77	0.58	0.37	0.89	0.79	0.60	0.39	0.92	0.82	0.62	0.40	0.93	0.83	0.63	0.40						
	Delta T	22	20	17	11	22	20	17	12	22	20	17	12	22	21	17	12	22	20	17	12	21	19	16	11						
	KW	2.71	2.76	2.84	2.93	2.90	2.96	3.04	3.14	3.07	3.13	3.22	3.32	3.22	3.28	3.38	3.48	3.34	3.41	3.51	3.62	3.45	3.52	3.63	3.74						
	AMPS	12.0	12.3	12.6	13.0	12.8	13.1	13.4	13.8	13.7	14.0	14.4	14.8	14.5	14.8	15.2	15.7	15.3	15.6	16.0	16.5	16.0	16.4	16.8	17.4						
75	HI PR	218	235	248	259	245	264	278	290	279	300	317	330	317	341	360	376	357	384	406	423	394	424	448	467						
	LO PR	107	114	124	132	113	120	131	140	117	125	136	145	123	131	143	153	129	138	150	160	134	142	155	165						

* IDB: Entering Indoor Dry Bulb Temperature

High and low pressures are measured at the liquid and suction access fittings.

NOTE: Shaded area is ACCA (TVA) conditions

COOLING PERFORMANCE DATA

GPC1342H41AA

MODEL: GPC1342H41A* EXPANDED PERFORMANCE DATA COOLING OPERATION

Design Subcooling, 12±3 °F @ the liquid access fitting connection AHRI 95 test conditions. Design Superheat 8±3 °F @ the compressor suction access fitting connection.

IDB*	Airflow	Outdoor Ambient Temperature																								
		65					75					85					105					115				
		59	63	67	71	75	59	63	67	71	75	59	63	67	71	75	59	63	67	71	75	59	63	67	71	75
80	1580	MBh	41.6	42.5	45.4	48.5	40.6	41.5	44.3	47.4	39.6	40.5	43.3	46.3	38.7	39.5	42.2	45.1	36.7	37.6	40.1	42.9	34.0	34.8	37.2	39.7
		ST	0.97	0.91	0.74	0.55	1.00	0.94	0.76	0.57	1.00	0.96	0.78	0.59	1.00	1.00	0.81	0.60	1.00	1.00	0.84	0.63	1.00	1.00	0.85	0.63
		Delta T	23	22	19	16	24	23	20	16	23	23	20	16	23	23	20	16	21	21	22	20	20	20	18	15
		KW	2.81	2.87	2.95	3.04	3.01	3.07	3.16	3.26	3.19	3.25	3.35	3.45	3.34	3.41	3.52	3.63	3.47	3.55	3.66	3.77	3.59	3.66	3.78	3.90
		AMPS	12.5	12.7	13.1	13.5	13.3	13.6	13.9	14.4	14.3	14.5	14.9	15.4	15.1	15.4	15.8	16.3	15.9	16.2	16.7	17.2	16.7	17.0	17.5	18.1
		HI PR	230	247	261	272	258	277	293	305	293	315	333	347	334	359	379	395	375	404	427	445	415	446	471	492
		LO PR	113	120	131	139	119	126	138	147	124	131	144	153	130	138	151	161	136	145	158	168	141	150	163	174
		MBh	40.4	41.3	44.1	47.1	39.4	40.3	43.1	46.0	38.5	39.3	42.0	44.9	37.6	38.4	41.0	43.8	35.7	36.5	39.0	41.6	33.0	33.8	36.1	38.6
		ST	0.92	0.86	0.70	0.53	0.95	0.89	0.73	0.54	0.98	0.92	0.75	0.56	1.00	0.95	0.77	0.58	1.00	0.98	0.80	0.60	1.00	0.99	0.81	0.60
		Delta T	24	23	20	16	25	24	20	16	25	24	20	16	24	24	21	16	23	23	20	16	22	22	19	15
KW	2.79	2.85	2.93	3.02	2.99	3.05	3.14	3.23	3.16	3.23	3.32	3.43	3.32	3.38	3.49	3.60	3.45	3.52	3.63	3.74	3.56	3.63	3.75	3.87		
AMPS	12.4	12.6	13.0	13.4	13.2	13.5	13.8	14.3	14.1	14.4	14.8	15.3	15.0	15.3	15.7	16.2	15.8	16.1	16.5	17.1	16.6	16.9	17.4	18.0		
HI PR	227	245	258	269	255	274	290	302	290	312	330	344	330	356	375	392	372	400	422	440	411	442	467	487		
LO PR	111	119	129	138	118	125	137	146	122	130	142	151	129	137	149	159	135	143	156	167	139	148	162	172		
MBh	37.3	38.1	40.7	43.5	36.4	37.2	39.7	42.5	35.5	36.3	38.8	41.5	34.7	35.4	37.8	40.5	32.9	33.6	36.0	38.4	30.5	31.2	33.3	35.6		
ST	0.89	0.83	0.68	0.51	0.92	0.86	0.70	0.52	0.94	0.88	0.72	0.54	0.97	0.91	0.74	0.56	1.01	0.95	0.77	0.58	1.02	0.96	0.78	0.58		
Delta T	25	23	20	16	25	24	21	17	25	24	21	17	25	24	21	17	25	24	21	16	23	22	19	15		
KW	2.73	2.78	2.86	2.95	2.92	2.98	3.07	3.16	3.09	3.15	3.25	3.35	3.24	3.31	3.41	3.51	3.37	3.44	3.54	3.65	3.48	3.55	3.66	3.77		
AMPS	12.1	12.4	12.7	13.1	12.9	13.2	13.5	13.9	13.8	14.1	14.5	14.9	14.6	14.9	15.3	15.8	15.4	15.7	16.2	16.7	16.2	16.5	17.0	17.5		
HI PR	220	237	251	261	247	266	281	293	281	303	320	333	320	345	364	380	360	388	410	427	398	429	453	472		
LO PR	108	115	126	134	114	121	133	141	119	126	138	147	125	133	145	154	131	139	152	162	135	144	157	167		
85	1580	MBh	42.3	43.1	45.2	48.2	41.3	42.1	44.1	47.1	40.3	41.1	43.1	45.9	39.4	40.1	42.0	44.8	37.4	38.1	39.9	42.6	34.6	35.3	37.0	39.4
		ST	1.00	0.98	0.88	0.71	1.00	1.00	0.91	0.74	1.00	1.00	0.94	0.76	1.00	1.00	0.97	0.78	1.00	1.00	0.96	0.81	1.00	1.00	0.96	0.82
		Delta T	25	24	23	20	24	25	23	20	23	24	23	20	23	23	20	20	22	22	23	20	20	21	22	19
		KW	2.83	2.89	2.97	3.06	3.03	3.09	3.19	3.28	3.21	3.28	3.38	3.48	3.37	3.44	3.54	3.65	3.50	3.57	3.68	3.80	3.62	3.69	3.81	3.93
		AMPS	12.6	12.8	13.2	13.6	13.4	13.7	14.0	14.5	14.4	14.7	15.1	15.5	15.2	15.5	15.9	16.4	16.0	16.3	16.8	17.4	16.8	17.2	17.7	18.3
		HI PR	232	250	263	275	260	280	296	308	296	318	336	351	337	363	383	399	379	408	431	449	419	451	476	496
		LO PR	114	121	132	141	120	128	139	149	125	133	145	154	131	139	152	162	137	146	160	170	142	151	165	176
		MBh	41.1	41.9	43.9	46.8	40.1	40.9	42.8	45.7	39.2	39.9	41.8	44.6	38.2	39.0	40.8	43.5	36.3	37.0	38.8	41.3	33.6	34.3	35.9	38.3
		ST	0.96	0.93	0.84	0.68	1.00	0.96	0.87	0.71	1.00	0.99	0.89	0.72	1.00	1.00	0.92	0.75	1.00	1.00	0.96	0.78	1.00	1.00	0.96	0.78
		Delta T	26	25	24	21	26	26	24	21	26	26	24	21	25	25	21	21	24	24	24	21	22	22	23	20
KW	2.81	2.87	2.95	3.04	3.01	3.07	3.16	3.26	3.19	3.25	3.35	3.45	3.34	3.41	3.52	3.63	3.47	3.55	3.66	3.77	3.59	3.66	3.78	3.90		
AMPS	12.5	12.7	13.1	13.5	13.3	13.6	13.9	14.4	14.3	14.5	14.9	15.4	15.1	15.4	15.8	16.3	15.9	16.2	16.7	17.2	16.7	17.0	17.5	18.1		
HI PR	230	247	261	272	258	277	293	305	293	315	333	347	334	359	379	395	375	404	427	445	415	446	471	492		
LO PR	113	120	131	139	119	126	138	147	124	131	144	153	130	138	151	161	136	145	158	168	141	150	163	174		
MBh	37.9	38.6	40.5	43.2	37.0	37.7	39.5	42.2	36.2	36.9	38.6	41.2	35.3	36.0	37.7	40.2	33.5	34.2	35.8	38.2	31.0	31.6	33.1	35.4		
ST	0.93	0.90	0.81	0.66	0.96	0.93	0.84	0.68	0.99	0.95	0.86	0.70	1.00	0.98	0.89	0.72	1.00	1.00	0.92	0.75	1.00	1.00	0.93	0.75		
Delta T	26	26	24	21	26	26	25	21	27	26	25	21	26	26	25	21	25	25	24	21	23	23	23	20		
KW	2.75	2.80	2.89	2.97	2.94	3.00	3.09	3.18	3.11	3.18	3.27	3.37	3.26	3.33	3.43	3.54	3.39	3.46	3.57	3.68	3.50	3.58	3.69	3.80		
AMPS	12.2	12.5	12.8	13.2	13.0	13.3	13.6	14.0	13.9	14.2	14.6	15.1	14.7	15.0	15.4	15.9	15.5	15.8	16.3	16.8	16.3	16.6	17.1	17.7		
HI PR	223	240	253	264	250	269	284	296	284	306	323	337	324	348	368	384	364	392	414	432	402	433	457	477		
LO PR	109	116	127	135	115	123	134	143	120	128	139	148	126	134	146	156	132	140	153	163	136	145	159	169		

* NOTE: Shaded areas is AHRI Rating Conditions IDB: Entering Indoor Dry Bulb Temperature KW = Total system power
High and low pressures are measured at the liquid and suction access fittings. AMPS: Unit amps (comp.+ evaporator + condenser fan motors)

COOLING PERFORMANCE DATA

GPC1348H41BA

MODEL: GPC1348H41** EXPANDED PERFORMANCE DATA COOLING OPERATION

Design Subcooling, 12±3 °F @ the liquid access fitting connection AHRI 95 test conditions. Design Superheat 8±3 °F @ the compressor suction access fitting connection.

IDB*	Airflow	Outdoor Ambient Temperature																								
		65			75			85			95			105			115									
		59	63	67	71	59	63	67	71	59	63	67	71	59	63	67	71	59	63	67	71					
70	1800	MBh	44.6	46.2	50.6	-	43.5	45.1	49.5	-	42.5	44.1	48.3	-	41.5	43.0	47.1	-	39.4	40.8	44.7	-	36.5	37.8	41.4	-
		ST	0.77	0.64	0.44	-	0.79	0.66	0.46	-	0.81	0.68	0.47	-	0.84	0.70	0.49	-	0.87	0.73	0.50	-	0.88	0.73	0.51	-
		Delta T	17	15	11	-	18	15	12	-	18	15	12	-	18	15	12	-	18	15	12	-	16	14	11	-
		KW	3.20	3.27	3.36	-	3.43	3.49	3.60	-	3.62	3.70	3.81	-	3.80	3.87	3.99	-	3.95	4.03	4.15	-	4.07	4.16	4.29	-
		AMPS	13.9	14.2	14.5	-	14.8	15.1	15.5	-	15.9	16.2	16.6	-	16.8	17.1	17.6	-	17.7	18.0	18.5	-	18.5	18.9	19.5	-
	HI PR	234	252	266	-	262	282	298	-	298	321	339	-	340	366	386	-	382	411	434	-	422	454	480	-	
	LO PR	112	119	130	-	118	125	137	-	123	130	142	-	129	137	149	-	135	143	157	-	139	148	162	-	
	MBh	43.3	44.9	49.2	-	42.3	43.8	48.0	-	41.3	42.8	46.9	-	40.3	41.7	45.7	-	38.3	39.6	43.4	-	35.4	36.7	40.2	-	
	ST	0.73	0.61	0.42	-	0.76	0.63	0.44	-	0.78	0.65	0.45	-	0.80	0.67	0.46	-	0.83	0.69	0.48	-	0.84	0.70	0.49	-	
	Delta T	18	16	12	-	18	16	12	-	18	16	12	-	19	16	12	-	18	16	12	-	17	15	11	-	
KW	3.18	3.24	3.34	-	3.40	3.47	3.57	-	3.60	3.67	3.78	-	3.77	3.85	3.96	-	3.92	4.00	4.12	-	4.04	4.12	4.25	-		
AMPS	13.8	14.1	14.4	-	14.7	15.0	15.4	-	15.7	16.0	16.5	-	16.6	17.0	17.4	-	17.5	17.9	18.4	-	18.4	18.8	19.3	-		
HI PR	231	249	263	-	260	279	295	-	295	318	336	-	336	362	382	-	378	407	430	-	418	450	475	-		
LO PR	110	118	128	-	117	124	136	-	121	129	141	-	127	136	148	-	134	142	155	-	138	147	160	-		
MBh	40.0	41.4	45.4	-	39.0	40.4	44.3	-	38.1	39.5	43.3	-	37.2	38.5	42.2	-	35.3	36.6	40.1	-	32.7	33.9	37.1	-		
ST	0.70	0.59	0.41	-	0.73	0.61	0.42	-	0.75	0.63	0.43	-	0.77	0.65	0.45	-	0.80	0.67	0.46	-	0.81	0.68	0.47	-		
Delta T	18	16	12	-	19	16	12	-	19	16	12	-	19	16	12	-	19	16	12	-	17	15	11	-		
KW	3.11	3.17	3.26	-	3.33	3.39	3.49	-	3.52	3.59	3.69	-	3.68	3.76	3.87	-	3.82	3.90	4.02	-	3.95	4.03	4.15	-		
AMPS	13.5	13.8	14.1	-	14.4	14.7	15.0	-	15.4	15.7	16.1	-	16.2	16.6	17.0	-	17.1	17.5	18.0	-	18.0	18.3	18.9	-		
HI PR	224	242	255	-	252	271	286	-	286	308	326	-	326	351	371	-	367	395	417	-	406	436	461	-		
LO PR	107	114	124	-	113	120	131	-	118	125	137	-	124	131	144	-	130	138	150	-	134	143	156	-		
75	1800	MBh	45.3	46.7	50.5	54.2	44.3	45.6	49.4	53.0	43.2	44.5	48.2	51.7	42.2	43.4	47.0	50.4	40.1	41.3	44.7	47.9	37.1	38.2	41.4	44.4
		ST	0.87	0.78	0.59	0.38	0.90	0.81	0.61	0.39	0.93	0.83	0.63	0.40	0.96	0.85	0.65	0.42	0.99	0.89	0.67	0.43	1.00	0.89	0.68	0.44
		Delta T	20	19	15	11	20	19	15	11	20	19	15	11	21	19	16	11	21	19	15	11	19	17	14	10
		KW	3.23	3.29	3.38	3.48	3.45	3.52	3.62	3.73	3.65	3.73	3.84	3.95	3.83	3.91	4.02	4.15	3.98	4.06	4.18	4.31	4.10	4.19	4.32	4.46
		AMPS	14.0	14.3	14.7	15.1	14.9	15.2	15.6	16.1	16.0	16.3	16.7	17.3	16.9	17.2	17.7	18.3	17.8	18.2	18.7	19.3	18.7	19.1	19.6	20.3
	HI PR	236	254	268	280	265	285	301	314	301	324	342	357	343	369	390	407	386	415	439	458	427	459	485	506	
	LO PR	113	120	131	139	119	127	138	147	124	132	144	153	130	138	151	161	136	145	158	169	141	150	164	174	
	MBh	44.0	45.3	49.1	52.7	43.0	44.3	47.9	51.4	42.0	43.2	46.8	50.2	41.0	42.2	45.6	49.0	38.9	40.1	43.4	46.5	36.0	37.1	40.2	43.1	
	ST	0.83	0.74	0.56	0.36	0.86	0.77	0.58	0.37	0.88	0.79	0.60	0.38	0.91	0.82	0.62	0.40	0.95	0.85	0.64	0.41	0.95	0.85	0.65	0.42	
	Delta T	21	19	16	11	21	20	16	11	21	20	16	11	21	20	16	11	21	19	16	11	20	18	15	10	
KW	3.21	3.27	3.36	3.46	3.43	3.50	3.60	3.71	3.62	3.70	3.81	3.92	3.80	3.88	3.99	4.12	3.95	4.03	4.15	4.28	4.07	4.16	4.29	4.42		
AMPS	13.9	14.2	14.5	15.0	14.8	15.1	15.5	16.0	15.9	16.2	16.6	17.1	16.8	17.1	17.6	18.1	17.7	18.0	18.5	19.1	18.5	18.9	19.5	20.1		
HI PR	234	252	266	277	262	282	298	311	298	321	339	354	340	366	386	403	382	411	434	453	422	454	480	501		
LO PR	112	119	130	138	118	125	137	146	123	130	142	152	129	137	149	159	135	144	157	167	140	148	162	173		
MBh	40.6	41.8	45.3	48.6	39.7	40.9	44.2	47.5	38.7	39.9	43.2	46.3	37.8	38.9	42.1	45.2	35.9	37.0	40.0	42.9	33.3	34.2	37.1	39.8		
ST	0.80	0.72	0.54	0.35	0.83	0.74	0.56	0.36	0.85	0.76	0.58	0.37	0.88	0.79	0.59	0.38	0.91	0.82	0.62	0.40	0.92	0.82	0.62	0.40		
Delta T	21	20	16	11	22	20	16	11	22	20	16	11	22	20	16	11	22	20	16	11	20	19	15	10		
KW	3.14	3.20	3.29	3.38	3.35	3.42	3.52	3.62	3.54	3.61	3.72	3.83	3.71	3.79	3.90	4.02	3.85	3.93	4.05	4.18	3.98	4.06	4.18	4.32		
AMPS	13.6	13.9	14.2	14.7	14.5	14.8	15.2	15.6	15.5	15.8	16.2	16.7	16.4	16.7	17.2	17.7	17.2	17.6	18.1	18.7	18.1	18.5	19.0	19.6		
HI PR	227	244	258	269	254	274	289	302	289	311	329	343	330	355	375	391	371	399	421	439	410	441	466	486		
LO PR	108	115	126	134	114	122	133	141	119	126	138	147	125	133	145	154	131	139	152	162	135	144	157	167		

* IDB: Entering Indoor Dry Bulb Temperature

High and low pressures are measured at the liquid and suction access fittings.

NOTE: Shaded area is ACCA (TVA) conditions

COOLING PERFORMANCE DATA

GPC1348H41BA

EXPANDED PERFORMANCE DATA

COOLING OPERATION

MODEL: GPC1348H41**

Design Subcooling, 12±3 °F @ the liquid access fitting connection AHRI 95 test conditions. Design Superheat 8±3 °F @ the compressor suction access fitting connection.

IDB*	Airflow	Outdoor Ambient Temperature																									
		65				75				85				95													
		59	63	67	71	59	63	67	71	59	63	67	71	59	63	67	71										
80	1800	MBh	46.1	47.2	50.4	53.9	45.1	46.1	49.2	52.6	44.0	45.0	48.0	51.4	42.9	43.9	46.9	50.1	40.8	41.7	44.5	47.6	37.8	38.6	41.2	44.1	
		ST	0.96	0.90	0.73	0.55	1.00	0.93	0.76	0.56	1.00	0.95	0.78	0.58	1.00	1.00	0.80	0.60	0.60	1.00	1.00	0.83	0.62	1.00	1.00	0.84	0.63
		Delta T	23	22	19	15	23	22	19	15	22	22	19	15	22	22	19	15	21	21	19	15	15	19	20	18	14
		KW	3.25	3.31	3.41	3.51	3.48	3.55	3.65	3.76	3.68	3.75	3.87	3.98	3.86	3.94	4.06	4.18	4.01	4.09	4.22	4.35	4.14	4.22	4.35	4.49	
		AMPS	14.1	14.4	14.8	15.2	15.0	15.3	15.7	16.2	16.1	16.4	16.9	17.4	17.0	17.4	17.9	18.4	17.9	18.3	18.8	19.4	18.8	19.2	19.8	20.4	
		HI PR	238	257	271	283	268	288	304	317	304	328	346	361	347	373	394	411	390	420	443	462	431	464	490	511	
		LO PR	114	121	132	141	120	128	140	149	125	133	145	155	131	140	153	162	138	146	160	170	142	151	165	176	
		MBh	44.8	45.8	48.9	52.3	43.8	44.7	47.8	51.1	42.7	43.7	46.6	49.9	41.7	42.6	45.5	48.6	39.6	40.5	43.2	46.2	36.7	37.5	40.0	42.8	
		ST	0.91	0.85	0.70	0.52	0.94	0.89	0.72	0.54	0.97	0.91	0.74	0.55	1.00	0.94	0.76	0.57	1.00	0.97	0.79	0.59	1.00	0.98	0.80	0.60	
		Delta T	23	22	20	16	24	23	20	16	24	23	20	16	24	23	20	16	24	23	20	16	21	21	18	15	
KW	3.23	3.29	3.38	3.48	3.45	3.52	3.62	3.73	3.65	3.73	3.84	3.95	3.83	3.91	4.02	4.15	3.98	4.06	4.18	4.31	4.11	4.19	4.32	4.46			
AMPS	14.0	14.3	14.7	15.1	14.9	15.2	15.6	16.1	16.0	16.3	16.7	17.3	16.9	17.2	17.7	18.3	17.8	18.2	18.7	19.3	18.7	19.1	19.6	20.3			
HI PR	236	254	268	280	265	285	301	314	301	324	342	357	343	369	390	407	386	415	439	458	427	459	485	506			
LO PR	113	120	131	139	119	127	138	147	124	132	144	153	130	138	151	161	136	145	158	169	141	150	164	174			
MBh	41.4	42.3	45.1	48.3	40.4	41.3	44.1	47.1	39.4	40.3	43.0	46.0	38.5	39.3	42.0	44.9	36.5	37.3	39.9	42.6	33.9	34.6	37.0	39.5			
ST	0.88	0.82	0.67	0.50	0.91	0.85	0.70	0.52	0.93	0.88	0.71	0.53	0.96	0.90	0.74	0.55	1.00	0.94	0.76	0.57	1.01	0.95	0.77	0.58			
Delta T	24	23	20	16	24	23	20	16	24	23	20	16	24	23	20	16	24	23	20	16	22	21	19	15			
KW	3.16	3.22	3.31	3.41	3.38	3.44	3.54	3.65	3.57	3.64	3.75	3.86	3.74	3.82	3.93	4.05	3.88	3.96	4.08	4.21	4.01	4.09	4.22	4.35			
AMPS	13.7	14.0	14.3	14.8	14.6	14.9	15.3	15.7	15.6	15.9	16.4	16.9	16.5	16.8	17.3	17.9	17.4	17.7	18.2	18.8	18.2	18.6	19.2	19.8			
HI PR	229	246	260	271	257	277	292	305	292	315	332	346	333	358	378	395	375	403	426	444	414	445	470	490			
LO PR	109	116	127	135	116	123	134	143	120	128	139	149	126	134	146	156	132	141	154	163	137	145	159	169			
85	1800	MBh	47.0	47.9	50.1	53.5	45.9	46.7	49.0	52.2	44.8	45.6	47.8	51.0	43.7	44.5	46.6	49.7	41.5	42.3	44.3	47.3	38.4	39.2	41.0	43.8	
		ST	1.00	0.97	0.87	0.71	1.00	1.00	0.90	0.73	1.00	1.00	0.93	0.75	1.00	1.00	0.96	0.78	1.00	1.00	0.99	0.81	1.00	1.00	1.00	0.81	
		Delta T	24	24	22	19	23	24	23	20	23	23	23	20	22	23	23	20	21	22	22	19	20	20	21	18	
		KW	3.28	3.34	3.43	3.54	3.50	3.57	3.68	3.79	3.71	3.78	3.90	4.02	3.89	3.97	4.09	4.21	4.04	4.12	4.25	4.38	4.17	4.26	4.39	4.53	
		AMPS	14.2	14.5	14.9	15.3	15.1	15.4	15.9	16.4	16.2	16.5	17.0	17.5	17.1	17.5	18.0	18.6	18.1	18.5	19.0	19.6	19.0	19.4	20.0	20.6	
		HI PR	241	259	274	285	270	291	307	320	307	331	349	364	350	377	398	415	394	424	448	467	435	468	495	516	
		LO PR	115	122	134	142	121	129	141	150	126	134	147	156	133	141	154	164	139	148	161	172	144	153	167	178	
		MBh	45.6	46.5	48.7	51.9	44.5	45.4	47.5	50.7	43.5	44.3	46.4	49.5	42.4	43.2	45.3	48.3	40.3	41.1	43.0	45.9	37.3	38.0	39.8	42.5	
		ST	0.96	0.92	0.83	0.67	0.99	0.96	0.86	0.70	1.00	0.98	0.88	0.72	1.00	1.00	0.91	0.74	1.00	1.00	0.95	0.77	1.00	1.00	0.96	0.77	
		Delta T	25	25	23	20	25	25	24	20	25	25	24	20	24	24	24	21	23	24	23	20	21	22	22	19	
KW	3.25	3.31	3.41	3.51	3.48	3.55	3.65	3.76	3.68	3.75	3.87	3.98	3.86	3.94	4.06	4.18	4.01	4.09	4.22	4.35	4.14	4.22	4.35	4.49			
AMPS	14.1	14.4	14.8	15.2	15.0	15.3	15.7	16.2	16.1	16.4	16.9	17.4	17.0	17.4	17.9	18.4	17.9	18.3	18.8	19.4	18.8	19.2	19.8	20.4			
HI PR	238	257	271	283	268	288	304	317	304	328	346	361	347	373	394	411	390	420	443	462	431	464	490	511			
LO PR	114	121	132	141	120	128	140	149	125	133	145	155	131	140	153	162	138	146	160	170	142	151	165	176			
MBh	42.1	42.9	44.9	47.9	41.1	41.9	43.9	46.8	40.1	40.9	42.8	45.7	39.1	39.9	41.8	44.6	37.2	37.9	39.7	42.4	34.4	35.1	36.8	39.2			
ST	0.92	0.89	0.80	0.65	0.95	0.92	0.83	0.67	0.98	0.94	0.85	0.69	1.00	0.97	0.88	0.71	1.00	1.00	0.91	0.74	1.00	1.00	0.92	0.75			
Delta T	25	25	24	20	26	25	24	21	26	25	24	21	26	26	24	21	24	25	24	21	23	23	22	19			
KW	3.18	3.24	3.33	3.43	3.40	3.47	3.57	3.68	3.60	3.67	3.78	3.89	3.77	3.84	3.96	4.08	3.91	3.99	4.12	4.24	4.04	4.12	4.25	4.38			
AMPS	13.8	14.1	14.4	14.9	14.7	15.0	15.4	15.9	15.7	16.0	16.5	17.0	16.6	17.0	17.4	18.0	17.5	17.9	18.4	19.0	18.4	18.8	19.3	20.0			
HI PR	231	249	263	274	260	279	295	308	295	318	335	348	336	362	382	399	378	407	430	448	418	450	475	495			
LO PR	110	117	128	137	117	124	136	144	121	129	141	150	127	136	148	158	133	142	155	165	138	147	160	171			

* NOTE: Shaded areas is A-HRI Rating Conditions
 High and low pressures are measured at the liquid and suction access fittings.
 IDB: Entering Indoor Dry Bulb Temperature
 K/W = Total system power
 AMPS: Unit amps (comp.+ evaporator + condenser fan motors)

COOLING PERFORMANCE DATA

GPC1360H41BA

MODEL: GPC1360H41** EXPANDED PERFORMANCE DATA COOLING OPERATION

Design Subcooling, 12±3 °F @ the liquid access fitting connection AHRI 95 test conditions. Design Superheat 8±3 °F @ the compressor suction access fitting connection.

IDB*	Airflow	Outdoor Ambient Temperature																																																						
		65					75					85					95					105					115																													
		59	63	67	71	75	59	63	67	71	75	59	63	67	71	75	59	63	67	71	75	59	63	67	71	75	59	63	67	71	75																									
70	2085	MBh	56.3	58.4	64.0	-	55.0	57.0	62.5	-	53.7	55.7	61.0	-	52.4	54.3	59.5	-	49.8	51.6	56.5	-	46.1	47.8	52.4	-	0.75	0.63	0.43	-	0.80	0.67	0.46	-	0.82	0.69	0.48	-	0.85	0.71	0.49	-	0.86	0.72	0.50	-										
		Delta T	19	16	12	-	19	16	12	-	19	16	12	-	19	16	12	-	19	16	12	-	19	16	12	-	18	15	12	-	3.99	4.07	4.20	-	4.56	4.66	4.82	-	4.80	4.91	5.07	-	5.01	5.12	5.29	-	5.18	5.30	5.48	-						
		KW	18.8	19.2	19.7	-	20.0	20.4	21.0	-	21.4	21.9	22.5	-	22.6	23.1	23.7	-	23.8	24.3	25.0	-	25.0	25.5	26.3	-	25.0	25.5	26.3	-	233	251	265	-	297	320	338	-	339	364	385	-	381	410	433	-	421	453	478	-						
		HI PR	109	116	127	-	115	123	134	-	120	128	139	-	126	134	146	-	126	134	146	-	132	141	153	-	137	145	159	-	54.7	56.7	62.1	-	53.4	55.4	60.7	-	52.2	54.1	59.2	-	48.3	50.1	54.9	-	44.8	46.4	50.9	-						
		Delta T	19	17	13	-	20	17	13	-	20	17	13	-	20	17	13	-	20	17	13	-	20	17	13	-	18	16	12	-	0.72	0.60	0.41	-	0.74	0.62	0.43	-	0.76	0.64	0.44	-	0.79	0.66	0.45	-	0.82	0.68	0.47	-	0.82	0.69	0.48	-		
	KW	3.96	4.04	4.17	-	4.26	4.35	4.49	-	4.53	4.63	4.78	-	4.76	4.87	5.03	-	4.97	5.08	5.24	-	5.14	5.25	5.43	-	5.14	5.25	5.43	-	18.7	19.1	19.5	-	19.9	20.3	20.8	-	21.3	21.7	22.3	-	22.5	22.9	23.6	-	23.7	24.1	24.8	-	24.8	25.3	26.1	-			
	AMPS	231	248	262	-	259	278	294	-	294	317	334	-	335	361	381	-	377	406	428	-	417	448	473	-	417	448	473	-	108	115	126	-	114	122	133	-	119	126	138	-	125	133	145	-	131	139	152	-	135	144	157	-			
	LO PR	105	112	122	-	111	118	129	-	115	123	134	-	121	129	141	-	121	129	141	-	127	135	147	-	131	140	152	-	50.5	52.3	57.3	-	49.3	51.1	56.0	-	48.1	49.9	54.7	-	47.0	48.7	53.3	-	44.6	46.2	50.7	-	41.3	42.8	46.9	-			
	Delta T	20	17	13	-	20	17	13	-	20	17	13	-	20	17	13	-	20	17	13	-	20	17	13	-	19	16	12	-	0.69	0.58	0.40	-	0.72	0.60	0.41	-	0.73	0.61	0.42	-	0.76	0.63	0.44	-	0.79	0.66	0.45	-	0.79	0.66	0.46	-			
	KW	3.86	3.94	4.07	-	4.16	4.24	4.38	-	4.42	4.51	4.66	-	4.65	4.75	4.90	-	4.84	4.95	5.11	-	5.01	5.12	5.29	-	5.01	5.12	5.29	-	18.3	18.6	19.1	-	19.5	19.8	20.4	-	20.8	21.2	21.8	-	22.0	22.4	23.0	-	23.1	23.6	24.2	-	24.2	24.7	25.4	-			
AMPS	224	241	254	-	251	270	285	-	285	307	324	-	325	350	369	-	366	394	416	-	404	435	459	-	404	435	459	-	105	112	122	-	111	118	129	-	115	123	134	-	121	129	141	-	127	135	147	-	131	140	152	-				
LO PR	105	112	122	-	111	118	129	-	115	123	134	-	121	129	141	-	121	129	141	-	127	135	147	-	131	140	152	-	57.3	59.0	63.9	68.5	56.0	57.6	62.4	66.9	54.6	56.3	60.9	65.3	53.3	54.9	59.4	63.8	50.6	52.1	56.4	60.6	46.9	48.3	52.3	56.1	46.9	48.3	52.3	56.1

IDB*	Airflow	Outdoor Ambient Temperature																																																				
		65					75					85					95					105					115																											
		59	63	67	71	75	59	63	67	71	75	59	63	67	71	75	59	63	67	71	75	59	63	67	71	75	59	63	67	71	75																							
75	2085	MBh	57.3	59.0	63.9	68.5	56.0	57.6	62.4	66.9	54.6	56.3	60.9	65.3	53.3	54.9	59.4	63.8	50.6	52.1	56.4	60.6	46.9	48.3	52.3	56.1	0.85	0.76	0.58	0.37	0.88	0.79	0.60	0.39	0.91	0.81	0.61	0.39	0.94	0.84	0.63	0.41	0.97	0.87	0.66	0.42	0.98	0.88	0.66	0.43				
		Delta T	22	20	16	11	22	20	16	11	22	20	16	11	22	20	16	11	22	20	16	11	22	20	16	11	20	19	15	11	4.02	4.10	4.23	4.37	4.33	4.42	4.56	4.71	4.60	4.70	4.86	5.02	4.84	4.95	5.11	5.29	5.05	5.16	5.33	5.51	5.23	5.34	5.52	5.71
		KW	19.0	19.3	19.8	20.4	20.2	20.6	21.1	21.8	21.6	22.0	22.6	23.3	22.8	23.3	23.9	24.7	24.0	24.5	25.2	26.0	25.2	25.8	26.5	27.4	25.2	25.8	26.5	27.4	235	253	267	279	264	284	300	313	300	323	341	356	342	368	389	405	385	414	437	456	425	457	483	504
		HI PR	110	117	128	137	117	124	136	144	121	129	141	150	127	136	148	158	133	142	155	165	138	147	160	171	138	147	160	171	55.6	57.3	62.0	66.5	54.3	55.9	60.6	65.0	53.0	54.6	59.1	63.4	51.8	53.3	57.7	61.9	49.2	50.6	54.8	58.8	45.5	46.9	50.8	54.5
		Delta T	22	21	17	12	23	21	17	12	23	21	17	12	23	21	17	12	23	21	17	12	23	21	17	12	21	19	16	11	0.81	0.73	0.55	0.35	0.84	0.75	0.57	0.37	0.86	0.77	0.59	0.38	0.89	0.80	0.60	0.39	0.93	0.83	0.63	0.40	0.93	0.84	0.63	0.41
	KW	3.99	4.07	4.20	4.34	4.29	4.39	4.53	4.68	4.57	4.66	4.82	4.98	4.80	4.91	5.07	5.24	5.01	5.12	5.29	5.47	5.18	5.30	5.48	5.66	5.18	5.30	5.48	5.66	18.8	19.2	19.7	20.3	20.0	20.4	21.0	21.6	21.4	21.9	22.5	23.2	22.6	23.1	23.7	24.5	23.8	24.3	25.0	25.8	25.0	25.5	26.3	27.1	
	AMPS	233	251	265	276	261	281	297	310	297	320	338	352	339	364	385	401	381	410	433	451	421	453	478	499	421	453	478	499	109	116	127	135	116	123	134	143	120	128	139	149	126	134	146	156	132	141	154	163	137	145	159	169	
	LO PR	109	116	127	135	116	123	134	143	120	128	139	149	126	134	146	156	132	141	154	163	137	145	159	169	137	145	159	169	51.3	52.9	57.2	61.4	50.2	51.6	55.9	60.0	49.0	50.4	54.6	58.6	47.8	49.2	53.2	57.1	45.4	46.7	50.6	54.3	42.0	43.3	46.8	50.3	
	Delta T	23	21	17	12	23	21	17	12	23	21	17	12	23	21	17	12	23	21	17	12	23	21	17	12	21	20	16	11	0.78	0.70	0.53	0.34	0.81	0.73	0.55	0.35	0.83	0.75	0.56	0.36	0.86	0.77	0.58	0.37	0.89	0.80	0.60	0.39	0.90	0.81	0.61	0.39	
	KW	3.89	3.97	4.10	4.23	4.19	4.28	4.42	4.56	4.45	4.55	4.70	4.85	4.68	4.79	4.94	5.11	4.88	4.99	5.15	5.33	5.05	5.16	5.34	5.52	5.05	5.16	5.34	5.52	18.4	18.8	19.3	19.8	19.6	20.0	20.5	21.1	21.0	21.4	21.9	22.6	22.1	22.6	23.2	23.9	23.3	23.8	24.4	25.2	24.4	24.9	25.7	26.5	
AMPS	226	243	257	268	254	273	288	301	288	310	328	342	328	353	373	389	369	398	420	438	408	439	464	484	408	439	464	484	106	113	123	131	112	119	130	139	116	124	135	144	122	130	142	151	128	136	149	159	133	141	154	164		
LO PR	106	113	123	131	112	119	130	139	116	124	135	144	122	130	142	151	128	136	149	159	133	141	154	164	133	141	154	164	51.3	52.9	57.2	61.4	50.2	51.6	55.9	60.0	49.0	50.4	54.6	58.6	47.8	49.2	53.2	57.1	45.4	46.7	50.6	54.3	42.0	43.3	46.8	50.3		

* IDB: Entering Indoor Dry Bulb Temperature

High and low pressures are measured at the liquid and suction access fittings.

NOTE: Shaded area is ACCA (TVA) conditions

COOLING PERFORMANCE DATA

GPC1360H41BA

MODEL: GPC1360H41** **EXPANDED PERFORMANCE DATA** **COOLING OPERATION**

Design Subcooling, 12±3 °F @ the liquid access fitting connection AHRI 95 test conditions. Design Superheat 8±3 °F @ the compressor suction access fitting connection.

IDB*	Airflow	Outdoor Ambient Temperature																							
		65				75				85				105				115							
		59	63	67	71	59	63	67	71	59	63	67	71	59	63	67	71	59	63	67	71				
80	MBh	58.3	59.6	63.7	68.1	57.0	58.2	62.2	66.5	55.6	56.8	60.7	64.9	54.3	55.4	59.2	63.3	51.5	52.7	56.3	60.1	47.7	48.8	52.1	55.7
	ST	0.94	0.88	0.71	0.53	0.97	0.91	0.74	0.55	1.00	0.93	0.76	0.57	1.00	0.96	0.78	0.59	1.00	1.00	0.81	0.61	1.00	1.00	0.82	0.61
	Delta T	24	23	20	16	24	23	20	16	25	23	20	16	24	24	20	16	23	23	20	16	21	22	19	15
	KW	4.05	4.14	4.27	4.41	4.36	4.46	4.60	4.75	4.64	4.74	4.90	5.06	4.88	4.99	5.16	5.33	5.09	5.21	5.38	5.56	5.27	5.39	5.57	5.76
	AMPS	19.1	19.5	20.0	20.6	20.3	20.7	21.3	21.9	21.8	22.2	22.8	23.5	23.0	23.5	24.1	24.9	24.2	24.7	25.4	26.2	25.4	26.0	26.7	27.6
	HI PR	238	256	270	282	267	287	303	316	303	326	345	359	345	372	393	409	389	418	442	461	429	462	488	509
	LO PR	112	119	130	138	118	125	137	146	122	130	142	152	129	137	149	159	135	143	157	167	139	148	162	173
	MBh	56.6	57.9	61.8	66.1	55.3	56.5	60.4	64.5	54.0	55.2	58.9	63.0	52.7	53.8	57.5	61.5	50.0	51.1	54.6	58.4	46.3	47.4	50.6	54.1
	ST	0.89	0.84	0.68	0.51	0.92	0.87	0.71	0.53	0.95	0.89	0.72	0.54	0.98	0.92	0.75	0.56	1.00	0.95	0.78	0.58	1.00	0.96	0.78	0.58
	Delta T	25	24	21	17	25	24	21	17	25	24	21	17	26	25	21	17	25	24	21	17	23	23	20	16
	KW	4.02	4.10	4.23	4.37	4.33	4.42	4.57	4.72	4.60	4.70	4.86	5.02	4.84	4.95	5.12	5.29	5.05	5.16	5.33	5.51	5.23	5.34	5.52	5.71
AMPS	19.0	19.3	19.8	20.4	20.2	20.6	21.1	21.8	21.6	22.0	22.6	23.3	22.8	23.3	23.9	24.7	24.0	24.5	25.2	26.0	25.2	25.8	26.5	27.4	
HI PR	235	253	267	279	264	284	300	313	300	323	341	356	342	368	389	405	385	414	437	456	425	457	483	504	
LO PR	110	117	128	137	117	124	136	144	121	129	141	150	127	136	148	158	133	142	155	165	138	147	160	171	
MBh	52.3	53.4	57.1	61.0	51.0	52.2	55.7	59.6	49.8	50.9	54.4	58.2	48.6	49.7	53.1	56.7	46.2	47.2	50.4	53.9	42.8	43.7	46.7	49.9	
ST	0.86	0.81	0.66	0.49	0.89	0.84	0.68	0.51	0.91	0.86	0.70	0.52	0.94	0.89	0.72	0.54	0.98	0.92	0.75	0.56	0.99	0.93	0.75	0.56	
Delta T	25	24	21	17	26	25	21	17	26	25	21	17	26	25	22	17	26	25	21	17	24	23	20	16	
KW	3.92	4.01	4.13	4.26	4.22	4.31	4.45	4.60	4.49	4.59	4.74	4.89	4.72	4.83	4.99	5.15	4.92	5.03	5.20	5.37	5.09	5.21	5.38	5.56	
AMPS	18.6	18.9	19.4	20.0	19.7	20.1	20.7	21.3	21.1	21.5	22.1	22.8	22.3	22.7	23.4	24.1	23.5	23.9	24.6	25.4	24.6	25.1	25.9	26.7	
HI PR	228	246	259	271	256	276	291	304	291	313	331	345	332	357	377	393	373	402	424	442	412	444	469	489	
LO PR	107	114	124	133	113	120	131	140	118	125	137	146	124	131	144	153	129	138	150	160	134	142	156	166	
85	MBh	59.3	60.5	63.3	67.6	58.0	59.1	61.9	66.0	56.6	57.7	60.4	64.4	55.2	56.3	58.9	62.9	52.4	53.5	56.0	59.7	48.6	49.5	51.9	55.3
	ST	0.98	0.95	0.85	0.69	1.00	0.98	0.89	0.72	1.00	1.00	0.91	0.74	1.00	1.00	0.94	0.76	1.00	1.00	0.97	0.79	1.00	1.00	0.98	0.80
	Delta T	26	25	24	21	26	26	24	21	25	25	24	21	24	25	24	21	23	24	24	21	21	22	22	19
	KW	4.08	4.17	4.30	4.44	4.40	4.50	4.64	4.79	4.68	4.78	4.94	5.10	4.93	5.03	5.20	5.38	5.13	5.25	5.42	5.61	5.32	5.44	5.62	5.81
	AMPS	19.2	19.6	20.1	20.7	20.5	20.9	21.4	22.1	21.9	22.4	23.0	23.7	23.2	23.6	24.3	25.1	24.4	24.9	25.6	26.4	25.6	26.2	26.9	27.8
	HI PR	240	258	273	284	269	290	306	319	306	330	348	363	349	375	396	414	392	422	446	465	434	467	493	514
	LO PR	113	120	131	139	119	127	138	147	124	132	144	153	130	138	151	161	136	145	158	168	141	150	164	174
	MBh	57.6	58.7	61.5	65.6	56.3	57.4	60.1	64.1	54.9	56.0	58.6	62.6	53.6	54.6	57.2	61.0	50.9	51.9	54.4	58.0	47.2	48.1	50.3	53.7
	ST	0.94	0.90	0.81	0.66	0.97	0.94	0.84	0.69	0.99	0.96	0.87	0.70	1.00	0.99	0.89	0.73	1.00	1.00	0.93	0.75	1.00	1.00	0.94	0.76
	Delta T	27	26	25	22	27	27	25	22	27	27	25	22	27	27	25	22	25	26	25	22	23	24	23	20
	KW	4.05	4.14	4.27	4.41	4.36	4.46	4.60	4.75	4.64	4.74	4.90	5.06	4.88	4.99	5.16	5.33	5.09	5.21	5.38	5.56	5.27	5.39	5.57	5.76
AMPS	19.1	19.5	20.0	20.6	20.3	20.7	21.3	21.9	21.8	22.2	22.8	23.5	23.0	23.5	24.1	24.9	24.2	24.7	25.4	26.2	25.4	26.0	26.7	27.6	
HI PR	238	256	270	282	267	287	303	316	303	326	345	359	345	372	393	409	389	418	442	461	429	462	488	509	
LO PR	112	119	130	138	118	125	137	146	122	130	142	152	129	137	149	159	135	143	157	167	139	148	162	173	
MBh	53.2	54.2	56.8	60.6	51.9	52.9	55.4	59.2	50.7	51.7	54.1	57.7	49.5	50.4	52.8	56.3	47.0	47.9	50.2	53.5	43.5	44.4	46.5	49.6	
ST	0.90	0.87	0.79	0.64	0.93	0.90	0.81	0.66	0.96	0.93	0.83	0.68	0.99	0.95	0.86	0.70	1.00	0.99	0.89	0.73	1.00	1.00	0.90	0.73	
Delta T	27	27	25	22	27	27	26	22	28	27	26	22	28	27	26	22	27	27	25	22	25	25	24	21	
KW	3.96	4.04	4.17	4.30	4.26	4.35	4.49	4.64	4.53	4.62	4.78	4.93	4.76	4.87	5.03	5.20	4.96	5.07	5.24	5.42	5.14	5.25	5.43	5.61	
AMPS	18.7	19.0	19.5	20.1	19.9	20.3	20.8	21.4	21.3	21.7	22.3	23.0	22.5	22.9	23.5	24.3	23.6	24.1	24.8	25.6	24.8	25.3	26.1	26.9	
HI PR	231	248	262	273	259	278	294	307	294	317	334	349	335	361	381	397	377	406	428	447	416	448	473	494	
LO PR	108	115	126	134	114	122	133	141	119	126	138	147	125	133	145	154	131	139	152	162	135	144	157	167	

* NOTE: Shaded areas is A-HRI Rating Conditions
High and low pressures are measured at the liquid and suction access fittings.
IDB: Entering Indoor Dry Bulb Temperature K/W = Total system power
AMPS: Unit amps (comp.+ evaporator + condenser fan motors)

COOLING PERFORMANCE DATA

PERFORMANCE TEST

All data based upon listed indoor dry bulb temperature. .00 inches external static pressure on coil of outdoor section. Indoor air cubic feet per minute (CFM) as listed in the Performance Data Sheets:

If conditions vary from this, results will change as follows:

1. As indoor dry bulb temperatures increase, a slight increase will occur in indoor air temperature drop (Delta T). Low and high side pressures and power will not change.
2. As indoor CFM decreases, a slight increase will occur in indoor temperature drop (Delta T). A slight decrease will occur in low and high side pressures and power.

A properly operating unit should be within plus or minus **3 degrees** of the typical (**Delta T**) value shown.

A properly operating unit should be within plus or minus **7 PSIG** of the **HI PR** shown.

A properly operating unit should be within plus or minus **3 PSIG** of the **LO PR** shown.

A properly operating unit should be within plus or minus **3 Amps** of the typical value shown.



HIGH VOLTAGE!
 DISCONNECT ALL POWER BEFORE SERVICING OR INSTALLING THIS UNIT. MULTIPLE POWER SOURCES MAY BE PRESENT. FAILURE TO DO SO MAY CAUSE PROPERTY DAMAGE, PERSONAL INJURY OR DEATH.

WARNING

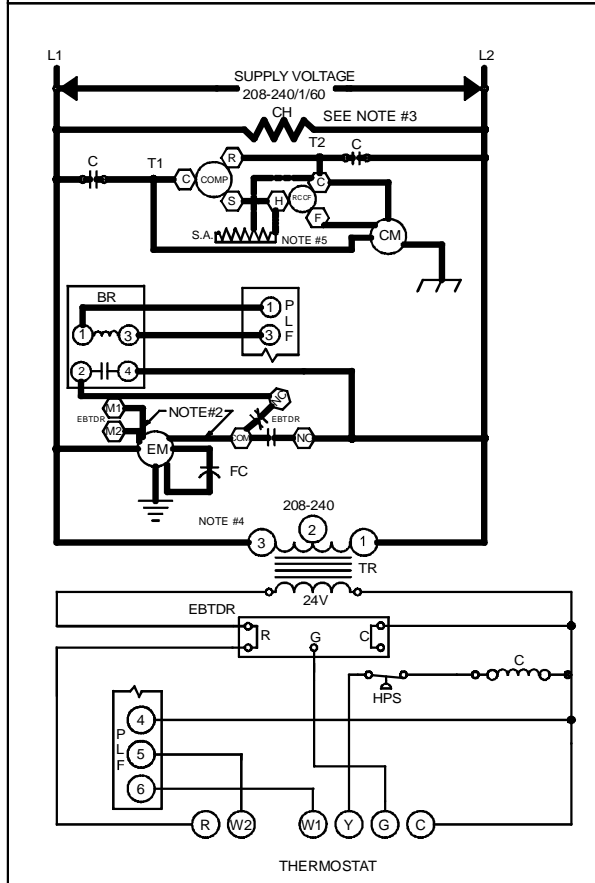
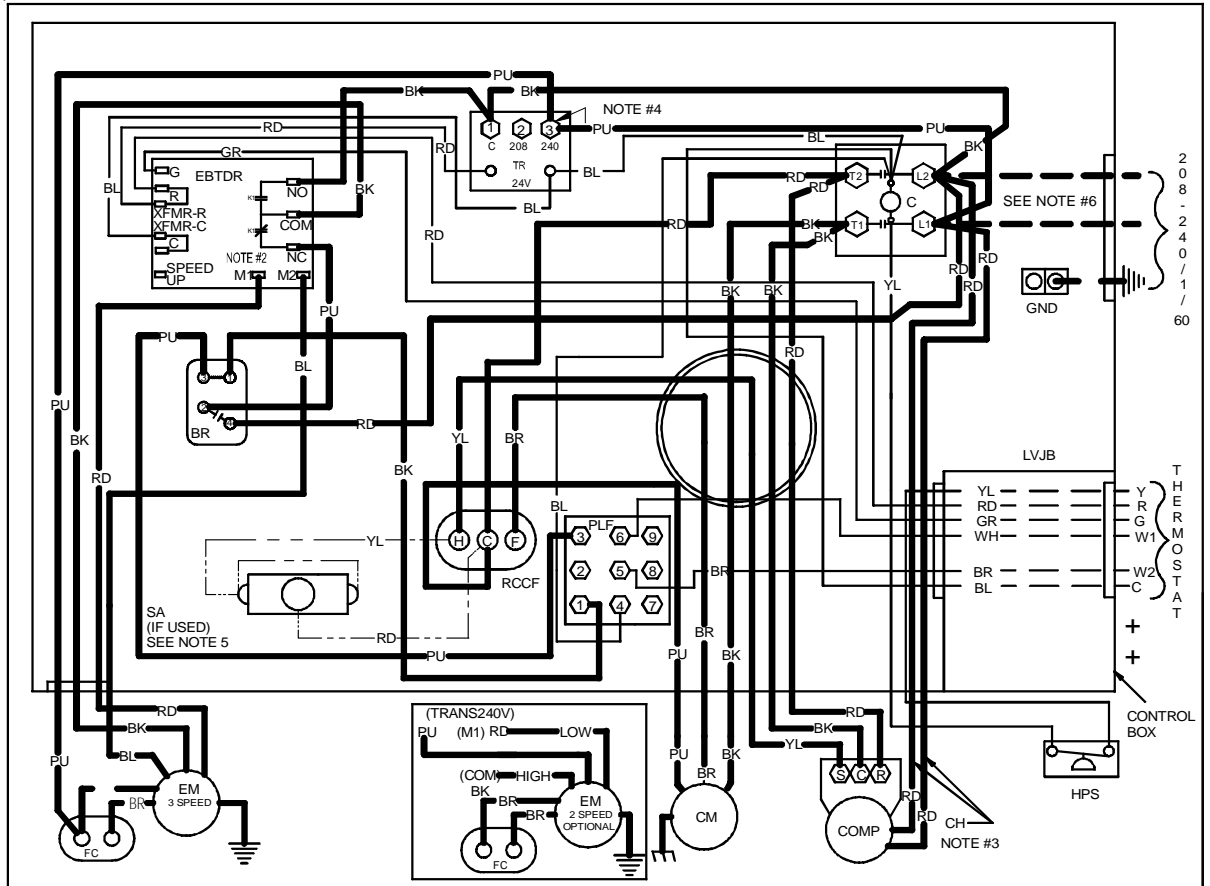

COMPONENT LEGEND

BR	BLOWER INTERLOCK RELAY
C	CONTACTOR
CH	CRANKCASE HEATER
CM	CONDENSER MOTOR
COMP	COMPRESSOR
EBTD	ELECTRONIC BLOWER TIME DELAY RELAY
EM	EVAPORATOR MOTOR
FC	FAN CAPACITOR
GND	EQUIPMENT GROUND
LVJB	LOW VOLTAGE JUNCTION BOX
PLF	FEMALE PLUG / CONNECTOR
RCCF	RUN CAPACITOR FOR COMPRESSOR AND FAN
SA	START ASSIST
TR	TRANSFORMER
HPS	HIGH PRESSURE SWITCH

FACTORY WIRING

— LINE VOLTAGE
 — LOW VOLTAGE
 - - - OPTIMAL HIGH VOLTAGE

FIELD WIRING

— HIGH VOLTAGE
 - - - LOW VOLTAGE

WIRE CODE

BK	BLACK
BL	BLUE
BR	BROWN
GR	GREEN
OR	ORANGE
PU	PURPLE
RD	RED
WH	WHITE
YL	YELLOW

NOTES:

- REPLACEMENT WIRE MUST BE SAME SIZE AND TYPE INSULATION AS ORIGINAL (AT LEAST 105°C) USE COPPER CONDUCTOR ONLY.
- TO CHANGE EVAPORATOR MOTOR SPEED REPLACE LEAD ON EBTDR "COM" WITH LEAD ON EBTDR "M1" OR "M2"
- CRANKCASE HEAT NOT SUPPLIED ON ALL UNITS.
- FOR 208 VOLT TRANSFORMER OPERATION MOVE PURPLE WIRES FROM TERMINAL 3 TO TERMINAL 2 ON TRANSFORMER.
- START ASSIST FACTORY EQUIPED WHEN REQUIRED
- USE COPPER CONDUCTORS ONLY
- ++ USE N.E.C. CLASS 2 WIRE

SEE UNIT RATING PLATE FOR TYPE AND SIZE OF OVER CURRENT PROTECTION

Wiring is subject to change. Always refer to the wiring diagram on the unit for the most up-to-date wiring.



HIGH VOLTAGE!
 DISCONNECT ALL POWER BEFORE SERVICING OR INSTALLING THIS UNIT. MULTIPLE POWER SOURCES MAY BE PRESENT. FAILURE TO DO SO MAY CAUSE PROPERTY DAMAGE, PERSONAL INJURY OR DEATH.

WARNING

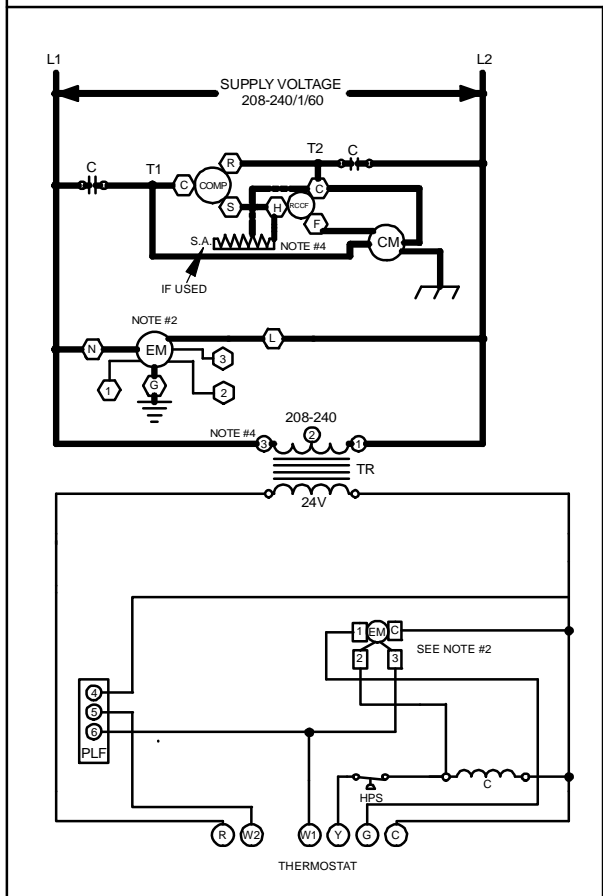
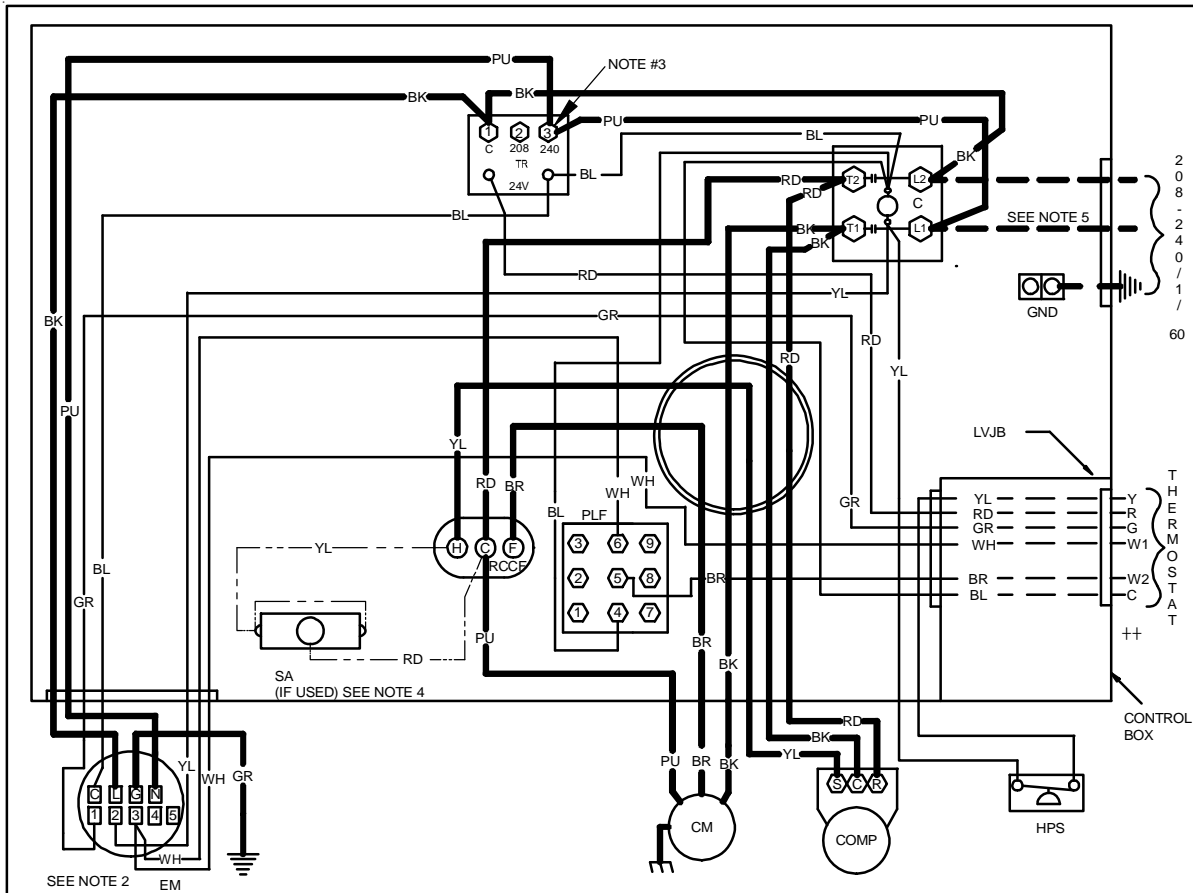

COMPONENT LEGEND		FACTORY WIRING
C	CONTACTOR	— LINE VOLTAGE
CM	CONDENSER MOTOR	— LOW VOLTAGE
COMP	COMPRESSOR	— OPTIMAL HIGH VOLTAGE
EM	EVAPORATOR MOTOR	--- VOLTAGE
GND	EQUIPMENT GROUND	
LVJB	LOW VOLTAGE JUNCTION BOX	
PLF	FEMALE PLUG / CONNECTOR	
RCCF	RUN CAPACITOR FOR COMPRESSOR AND FAN	
SA	START ASSIST	
TR	TRANSFORMER	
HPS	HIGH PRESSURE SWITCH	
		FIELD WIRING
		— HIGH VOLTAGE
		--- LOW VOLTAGE
		WIRE CODE
		BK BLACK
		BL BLUE
		BR BROWN
		GR GREEN
		OR ORANGE
		PU PURPLE
		RD RED
		WH WHITE
		YL YELLOW

- NOTES:**
- REPLACEMENT WIRE MUST BE SAME SIZE AND TYPE INSULATION AS ORIGINAL (AT LEAST 105°C) USE COPPER CONDUCTOR ONLY.
 - TO CHANGE EVAPORATOR MOTOR SPEED MOVE WHITE AND YELLOW LEADS FROM EM "2" AND "3" TO "4" AND "5". IF BOTH LEADS ARE ENERGIZED, THE HIGHER SPEED SETTING IS USED.
 - FOR 208 VOLT TRANSFORMER OPERATION MOVE PURPLE WIRES FROM TERMINAL 3 TO TERMINAL 2 ON TRANSFORMER.
 - START ASSIST FACTORY EQUIPED WHEN REQUIRED
 - USE COPPER CONDUCTORS ONLY.
- ++ USE N.E.C. CLASS 2 WIRE

SEE UNIT RATING PLATE FOR TYPE AND SIZE OF OVER CURRENT PROTECTION

Wiring is subject to change. Always refer to the wiring diagram on the unit for the most up-to-date wiring.

GPC 13 SEER R-410A 5 mm Package Air Conditioners

GPC1324H41AB

GPC1342H41AB

GPC1330H41AB

GPC1349H41AA

GPC1336H41AB

GPC1360H41BB

PRODUCT DESIGN

GPC Package Cooling Units are designed for outdoor installations only in either residential or light commercial applications.

The connecting ductwork (Supply and Return) can be connected for either horizontal or vertical airflow. In the vertical application a matching Roof Curb is recommended.

A return air filter must be installed behind the return air grille(s) or provision must be made for a filter in an accessible location within the return air duct. The minimum filter area should not be less than those sizes listed in the Specification Section. Under no circumstances should the unit be operated without return air filters.

A 3/4" PVC pipe is provided for removal of condensate water from the indoor coil. In order to provide proper condensate flow, a drain trap is supplied and shipped loose inside the unit for field installation. (Do not reduce the drain line size.)

Refrigerant flow control is achieved by use of restrictor orifices. GPC units use the FasTest Access Fitting System with a saddle that is either soldered to the suction and liquid lines or is fastened with a locking nut to the access fitting box (core) and then screwed into the saddle. **Do not remove the core from the saddle until the refrigerant charge has been removed. Failure to do so could result in property damage or personal injury.**

The single phase units use permanent split capacitor (PSC) design compressors. Starting components are therefore not required for these units. A low microfarad run capacitor assists the compressor to start and remains in the circuit during operation.

The outdoor fan and indoor blower motors are single phase capacitor type motors with the exception of the GPC1360H41* units which have X-13 indoor blower motors that are energized by a 24V signal from the thermostat and are constant torque motors with very low power consumption. The X-13 features an integral control module.

Air for condensing (cooling cycle) is drawn through the outdoor coil by a propeller fan, and is discharged vertically out the top of the unit. The outdoor coil is designed for .0 static. No additional restriction (ductwork) shall be applied.

Conditioned air is drawn through the filter(s), field installed, across the coil and back into the conditioned space by the indoor blower.

GPC1324-60H41** use Copeland Scroll Compressors. There are a number of design characteristics which are different from the traditional reciprocating compressors.

- Due to their design Scroll Compressors are inherently more tolerant of liquid refrigerant. **NOTE:** Even though the compressor section of a Scroll compressor is more tolerant of liquid refrigerant, continued floodback or flooded start conditions may wash oil from the bearing surfaces causing premature bearing failure.
- Scroll Compressors use white oil which is compatible with 3GS oil which may be used if additional oil is required.
- Operating pressures and amp draws may differ from standard reciprocating compressors. This information may be found in the "Cooling Performance Data" section.

PRODUCT DESIGN

Location and Clearances

NOTE: To ensure proper condensate drainage, unit must be installed in a level position.

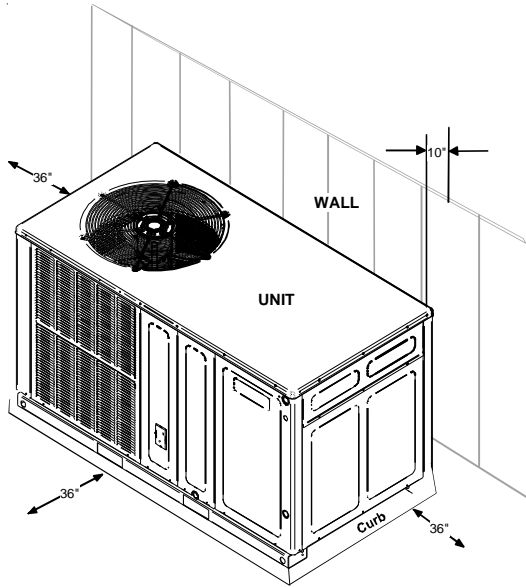

In installations where the unit is installed above ground level and not serviceable from the ground (Example: Roof Top installations), the installer must provide service platform for service person with rails or guards in accordance with local codes or ordinances or in their absence with the latest edition of the Uniform Mechanical Code Section 305.

NOTE: Unit can also use roof curb.

WARNING

TO PREVENT POSSIBLE PROPERTY DAMAGE, THE UNIT SHOULD REMAIN IN AN UPRIGHT POSITION DURING ALL RIGGING AND MOVING OPERATIONS. TO FACILITATE LIFTING AND MOVING IF A CRANE IS USED, PLACE THE UNIT IN AN ADEQUATE CABLE SLING.

Refer to Roof Curb Installation Instructions for proper curb installation. Curbing must be installed in compliance with the National Roofing Contractors Association Manual.

Outside Slab Installation - Horizontal (H)

Minimum clearances are required to avoid air recirculation and keep the unit operating at peak efficiency.

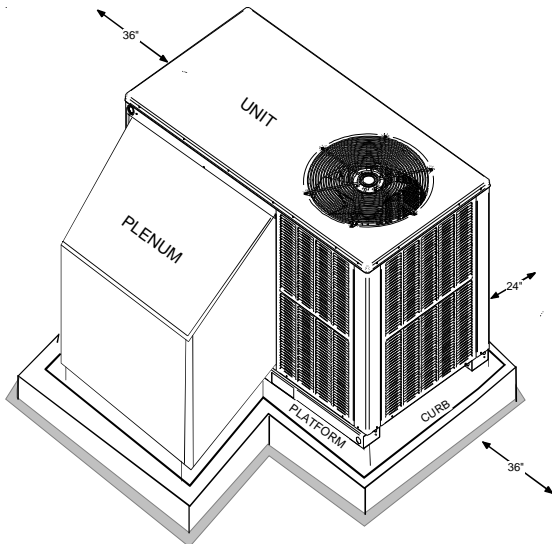

Rooftop Installation - Horizontal (H)

PACKAGE COOLING SPECIFICATIONS

GPC13[24-36]H41AB

MODELS WITH 5MM COILS

		GPC1324H41AB	GPC1330H41AB	GPC1336H41AB
COOLING CAPACITY	COOLING CAPACITY, BTUH	24,000	28,600	36,000
	SEER	13.0	13.0	13.0
UNIT ELECTRICAL SPECIFICATION	VOLTAGE (NAMEPLATE)	208-230/1/60	208-230/1/60	208-230/1/60
	AMPS (TOTAL)	16.1	15.76	20.06
	MINIMUM CIRCUIT AMPACITY	19.5	19	24.2
	MAXIMUM OVERCURRENT PROTECTION ⁽¹⁾	30	30	40
COMPRESSOR	TYPE	SCROLL	SCROLL	SCROLL
	RATED LOAD AMPS	13.5	12.8	16.7
	LOCKED ROTOR AMPS	58.3	64	79
CONDENSER FAN MOTOR	HORSEPOWER	1/6	1/6	1/4
	RPM	815	815	830
	FULL LOAD AMPS	1.1	1.1	1.5
	LOCKED ROTOR AMPS	1.7	1.7	3.0
CONDENSER FAN	BLADE DIAMETER (INCHES) /# OF BLADES	22 / 2	22 / 2	22 / 4
CONDENSER COIL	FACE AREA - SQ. FT.	12.3	12.3	12.3
	NUMBER OF ROWS	1	1	1
	FINS PER INCH	26	26	26
EVAPORATOR BLOWER MOTOR	HORSEPOWER - NO. OF SPEEDS	1/4 - 3	1/3 - 3	1/3 - 3
	FULL LOAD AMPS	1.5	1.86	1.86
	LOCKED ROTOR AMPS	2.2	3.2	3.2
	MOTOR SPEED TAP - COOLING	MEDIUM	LOW	LOW
	RPM	1075	1075	1075
EVAPORATOR BLOWER	DIAMETER X WIDTH (INCHES)	9 x 6	9 x 6	9 x 8
	RATED SCFM COOLING	815	1,080	1,205
	MAX EXTERNAL STATIC PRESS ("w.c.)	0.5	0.5	0.5
EVAPORATOR COIL	FACE AREA - SQ. FT.	4.6	4.6	5.2
	NUMBER OF ROWS	3	3	3
	FINS PER INCH	14	14	14
GENERAL INFORMATION	FILTER SIZE - SQ. FT. *	20 x 20 x 1	20x 25 x 1	25 x 25 x 1
	DRAIN SIZE (INCHES)	3/4"	3/4"	3/4"
	EXPANSION DEVICE	ORIFICE (0.057)	ORRIFICE (0.062)	ORIFICE (0.068)
	REFRIGERANT CHARGE R-410A (Oz.)	63	62	61
	POWER SUPPLY CONDUIT KNOCKOUT SIZE (IN.)	3/4, 1, 1-1/4	3/4, 1, 1-1/4	3/4, 1, 1-1/4
	LOW VOLTAGE CONDUIT KNOCKOUT SIZE (IN.)	1/2	1/2	1/2
	SHIPPING WEIGHT LBS.	290	290	370
	OPERATING WEIGHT LBS.	280	280	360

⁽¹⁾ Maximum Overcurrent Protection Device: **MUST** use Time Delay Fuse or HACR type Circuit Breaker of the same size as noted.

* Calculated external filter size based on air velocity of 300 ft/min.

Wire size should be determined in accordance with National Electrical Codes. Extensive wire runs will require larger wire sizes.

Unit specifications are subject to change without notice. **ALWAYS** refer to the units serial plate for the most up-to-date general and electrical information.

IMPORTANT: While this data is presented as a guide, it is important to electrically connect the unit and properly size wires and fuses/circuit breakers in accordance with the National Electrical Code and/or all local codes. Data shown is w/o electric heaters.

PACKAGE COOLING SPECIFICATIONS

GPC1342H41AB
GPC1349H41AA
GPC1360H41BB

MODELS WITH 5MM COILS

		GPC1342H41AB	GPC1349H41AA	GPC1360H41BB
COOLING CAPACITY	COOLING CAPACITY, BTUH	41,000	45,500	57,500
	SEER	13.0	13.0	13.0
UNIT ELECTRICAL SPECIFICATION	VOLTAGE (NAMEPLATE)	208-230/1/60	208-230/1/60	208-230/1/60
	AMPS (TOTAL)	22.17	24.17	33.6
	MINIMUM CIRCUIT AMPACITY	26.6	29.2	40.2
	MAXIMUM OVERCURRENT PROTECTION ⁽¹⁾	40	45	60
COMPRESSOR	TYPE	SCROLL	SCROLL	SCROLL
	RATED LOAD AMPS	17.9	19.9	26.4
	LOCKED ROTOR AMPS	112	109	134
CONDENSER FAN MOTOR	HORSEPOWER	1/4	1/4	1/4
	RPM	1075	1075	1075
	FULL LOAD AMPS	1.4	1.4	1.4
	LOCKED ROTOR AMPS	2.9	2.9	2.9
CONDENSER FAN	BLADE DIAMETER (INCHES) /# OF BLADES	22 / 4	22 / 4	22 / 4
CONDENSER COIL	FACE AREA - SQ. FT.	16.0	16.0	19.5
	NUMBER OF ROWS	1	1	1
	FINS PER INCH	28	28	28
EVAPORATOR BLOWER MOTOR	HORSEPOWER - NO. OF SPEEDS	1/2 - 3	1/2 - 3	3/4 - 3
	FULL LOAD AMPS	2.87	2.87	5.8
	LOCKED ROTOR AMPS	4.9	4.9	NA
	MOTOR SPEED TAP - COOLING	LOW	MEDIUM	T2
	RPM	1075	1075	1075
EVAPORATOR BLOWER	DIAMETER X WIDTH (INCHES)	10 x 8	10 x 8	11 x 8
	RATED SCFM COOLING	1,410	1,585	1,850
	MAX EXTERNAL STATIC PRESS ("w.c.)	0.5	0.5	0.5
EVAPORATOR COIL	FACE AREA - SQ. FT.	6.2	6.2	7.0
	NUMBER OF ROWS	4	4	4
	FINS PER INCH	14	14	14
GENERAL INFORMATION	FILTER SIZE - SQ. FT. *	(2) 20 x 20 x 1	(2) 20 x 20 x 1	(2) 20 x 25 x 1
	DRAIN SIZE (INCHES)	3/4"	3/4"	3/4"
	EXPANSION DEVICE	ORIFICE (0.072)	ORRIFICE (0.078)	ORIFICE (0.088)
	REFRIGERANT CHARGE R-410A (Oz.)	88	80	93
	POWER SUPPLY CONDUIT KNOCKOUT SIZE (IN.)	3/4, 1, 1-1/4	3/4, 1, 1-1/4	3/4, 1, 1-1/4
	LOW VOLTAGE CONDUIT KNOCKOUT SIZE (IN.)	1/2	1/2	1/2
	SHIPPING WEIGHT LBS.	370	400	400
	OPERATING WEIGHT LBS.	360	390	390

⁽¹⁾ Maximum Overcurrent Protection Device: **MUST** use Time Delay Fuse or HACR type Circuit Breaker of the same size as noted.

* Calculated external filter size based on air velocity of 300 ft/min.

Wire size should be determined in accordance with National Electrical Codes. Extensive wire runs will require larger wire sizes.

Unit specifications are subject to change without notice. **ALWAYS** refer to the units serial plate for the most up-to-date general and electrical information.

IMPORTANT: While this data is presented as a guide, it is important to electrically connect the unit and properly size wires and fuses/circuit breakers in accordance with the National Electrical Code and/or all local codes. Data shown is w/o electric heaters.

COOLING PERFORMANCE DATA

5MM COILS

GPC1324H41AB

EXPANDED PERFORMANCE DATA

EXPANDED PERFORMANCE DATA

MODEL: GPC1324H41A*

IDB*	Airflow	Outdoor Ambient Temperature																								
		65				75				85				95				105				115				
		59	63	67	71	59	63	67	71	59	63	67	71	59	63	67	71	59	63	67	71	59	63	67	71	
70	MBh	23.2	24.0	26.3	-	22.6	23.5	25.7	-	22.1	22.9	25.1	-	21.6	22.3	24.5	-	20.5	21.2	23.3	-	19.0	19.7	21.5	-	
	S/T	1.00	1.00	1.00	-	1.00	1.00	1.00	-	1.00	1.00	1.00	-	1.00	1.00	1.00	-	1.00	1.00	1.00	-	1.00	1.00	1.00	-	
	Delta T	22	23	25	-	22	23	25	-	21	22	24	-	21	22	24	-	20	21	23	-	18	19	21	-	
	KW	1.63	1.67	1.72	-	1.75	1.79	1.84	-	1.86	1.90	1.96	-	1.95	1.99	2.06	-	2.03	2.07	2.14	-	2.10	2.14	2.21	-	
	AMPS	7.1	7.2	7.4	-	7.6	7.7	7.9	-	8.1	8.3	8.5	-	8.6	8.8	9.0	-	9.0	9.2	9.5	-	9.5	9.7	10.0	-	
	HI PR	217	234	247	-	244	263	277	-	278	299	315	-	316	340	359	-	356	383	404	-	393	423	447	-	
	LO PR	110	117	127	-	116	123	135	-	121	128	140	-	127	135	147	-	133	141	154	-	137	146	159	-	
	MBh	22.8	23.7	25.9	-	22.3	23.1	25.3	-	21.8	22.6	24.7	-	21.2	22.0	24.1	-	20.2	20.9	22.9	-	18.7	19.4	21.2	-	
	S/T	1.00	1.00	1.00	-	1.00	1.00	1.00	-	1.00	1.00	1.00	-	1.00	1.00	1.00	-	1.00	1.00	1.00	-	1.00	1.00	1.00	-	
	Delta T	25	26	28	-	24	25	27	-	24	24	27	-	23	24	26	-	22	23	25	-	20	21	23	-	
KW	1.63	1.66	1.71	-	1.74	1.78	1.83	-	1.85	1.89	1.95	-	1.94	1.98	2.04	-	2.02	2.06	2.13	-	2.09	2.13	2.20	-		
AMPS	7.0	7.2	7.4	-	7.5	7.7	7.9	-	8.1	8.2	8.5	-	8.5	8.7	9.0	-	9.0	9.2	9.5	-	9.5	9.7	9.9	-		
HI PR	216	232	245	-	242	261	275	-	276	297	313	-	314	338	357	-	353	380	401	-	390	420	443	-		
LO PR	109	116	127	-	115	123	134	-	120	127	139	-	126	134	146	-	132	140	153	-	136	145	158	-		
75	MBh	21.7	22.5	24.6	-	21.2	22.0	24.1	-	20.7	21.4	23.5	-	20.2	20.9	22.9	-	19.2	19.9	21.8	-	17.8	18.4	20.2	-	
	S/T	1.00	1.00	1.00	-	1.00	1.00	1.00	-	1.00	1.00	1.00	-	1.00	1.00	1.00	-	1.00	1.00	1.00	-	1.00	1.00	1.00	-	
	Delta T	27	28	30	-	26	27	29	-	25	26	29	-	25	26	28	-	23	24	27	-	22	23	25	-	
	KW	1.60	1.63	1.68	-	1.72	1.75	1.81	-	1.82	1.86	1.92	-	1.91	1.95	2.01	-	1.99	2.03	2.09	-	2.05	2.10	2.16	-	
	AMPS	6.9	7.1	7.3	-	7.4	7.6	7.8	-	7.9	8.1	8.3	-	8.4	8.6	8.8	-	8.9	9.0	9.3	-	9.3	9.5	9.8	-	
	HI PR	212	228	241	-	237	256	270	-	270	291	307	-	308	331	350	-	346	372	393	-	382	412	435	-	
	LO PR	107	114	124	-	113	120	131	-	117	125	136	-	123	131	143	-	129	137	150	-	134	142	155	-	
	75	MBh	23.6	24.3	26.3	28.2	23.0	23.7	25.7	27.5	22.5	23.1	25.0	26.9	21.9	22.6	24.4	26.2	20.8	21.4	23.2	24.9	19.3	19.9	21.5	23.1
		S/T	1.00	1.00	1.00	1.00	1.00	1.00	1.00	1.00	1.00	1.00	1.00	1.00	1.00	1.00	1.00	1.00	1.00	1.00	1.00	1.00	1.00	1.00	1.00	1.00
		Delta T	23	23	25	27	22	23	25	27	22	22	24	26	21	22	24	26	20	21	22	24	19	19	21	22
KW		1.65	1.68	1.73	1.78	1.77	1.80	1.86	1.92	1.87	1.91	1.97	2.04	1.97	2.01	2.07	2.14	2.05	2.09	2.16	2.23	2.12	2.16	2.23	2.30	
AMPS		7.1	7.3	7.5	7.7	7.6	7.8	8.0	8.2	8.2	8.3	8.6	8.8	8.6	8.8	9.1	9.4	9.1	9.3	9.6	9.9	9.6	9.8	10.1	10.4	
HI PR		220	236	250	260	247	265	280	292	280	302	319	332	319	344	363	378	359	387	408	426	397	427	451	470	
LO PR		111	118	129	137	117	125	136	145	122	130	141	151	128	136	149	158	134	143	156	166	139	147	161	171	
MBh		23.2	23.9	25.9	27.8	22.7	23.4	25.3	27.1	22.1	22.8	24.7	26.5	21.6	22.2	24.1	25.8	20.5	21.1	22.9	24.5	19.0	19.6	21.2	22.7	
S/T		1.00	1.00	1.00	1.00	1.00	1.00	1.00	1.00	1.00	1.00	1.00	1.00	1.00	1.00	1.00	1.00	1.00	1.00	1.00	1.00	1.00	1.00	1.00	1.00	
Delta T		25	26	28	30	25	25	27	29	24	25	27	29	23	24	26	28	22	23	25	27	21	21	23	25	
KW	1.64	1.67	1.72	1.77	1.76	1.79	1.85	1.91	1.86	1.90	1.96	2.02	1.96	2.00	2.06	2.13	2.04	2.08	2.15	2.22	2.10	2.15	2.22	2.29		
AMPS	7.1	7.2	7.4	7.7	7.6	7.7	7.9	8.2	8.1	8.3	8.5	8.8	8.6	8.8	9.0	9.3	9.1	9.3	9.5	9.8	9.5	9.7	10.0	10.4		
HI PR	218	235	248	259	245	263	278	290	278	300	316	330	317	341	360	376	357	384	405	423	394	424	448	467		
LO PR	110	117	128	136	116	124	135	144	121	129	140	150	127	135	148	157	133	142	155	165	138	146	160	170		
75	MBh	22.1	22.7	24.6	26.4	21.5	22.2	24.0	25.8	21.0	21.7	23.4	25.2	20.5	21.1	22.9	24.5	19.5	20.1	21.7	23.3	18.1	18.6	20.1	21.6	
	S/T	1.00	1.00	1.00	1.00	1.00	1.00	1.00	1.00	1.00	1.00	1.00	1.00	1.00	1.00	1.00	1.00	1.00	1.00	1.00	1.00	1.00	1.00	1.00	1.00	
	Delta T	27	28	30	32	26	27	29	32	26	27	29	31	25	26	28	30	24	25	27	29	22	23	25	26	
	KW	1.61	1.65	1.69	1.75	1.73	1.77	1.82	1.88	1.83	1.87	1.93	1.99	1.93	1.97	2.03	2.09	2.00	2.05	2.11	2.18	2.07	2.11	2.18	2.25	
	AMPS	7.0	7.1	7.3	7.6	7.5	7.6	7.8	8.1	8.0	8.2	8.4	8.7	8.5	8.6	8.9	9.2	8.9	9.1	9.4	9.7	9.4	9.6	9.9	10.2	
	HI PR	214	230	243	253	240	258	273	284	273	294	310	323	311	334	353	368	350	376	397	414	386	416	439	458	
	LO PR	108	115	125	133	114	121	132	141	118	126	138	147	124	132	145	154	130	139	151	161	135	144	157	167	

* IDB: Entering Indoor Dry Bulb Temperature

High and low pressures are measured at the liquid and suction access fittings.

NOTE: Shaded area is ACCA (TVA) conditions

IDB*	Airflow	Outdoor Ambient Temperature																													
		65					75					85					95					105					115				
		59	63	67	71	75	59	63	67	71	75	59	63	67	71	75	59	63	67	71	75	59	63	67	71	75	59	63	67	71	75
80	950	MBh	24.0	24.5	26.2	28.0	23.4	23.9	25.6	27.3	22.9	23.4	25.0	26.7	22.3	22.8	24.4	26.0	21.2	21.7	23.1	24.7	19.6	20.1	21.4	22.9					
		S/T	1.00	1.00	1.00	1.00	1.00	1.00	1.00	1.00	1.00	1.00	1.00	1.00	1.00	1.00	1.00	1.00	1.00	1.00	1.00	1.00	1.00	1.00	1.00	1.00	1.00				
	850	Delta T	23	24	25	27	23	23	25	26	22	23	24	26	22	22	24	25	21	21	22	24	19	19	21	22					
		KW	1.66	1.69	1.74	1.80	1.78	1.82	1.87	1.93	1.89	1.93	1.99	2.05	1.98	2.03	2.09	2.16	2.06	2.11	2.18	2.25	2.13	2.18	2.25	2.32					
	750	AMPS	7.2	7.3	7.5	7.8	7.7	7.8	8.0	8.3	8.2	8.4	8.6	8.9	8.7	8.9	9.2	9.5	9.2	9.4	9.7	10.0	9.7	9.9	10.2	10.5					
		HI PR	222	239	252	263	249	268	283	295	283	305	322	336	323	347	367	382	363	391	412	430	401	431	456	475					
	85	950	LO PR	112	119	130	139	118	126	137	146	123	131	143	152	129	137	150	160	135	144	157	167	140	149	163	173				
			MBh	23.6	24.1	25.8	27.6	23.1	23.6	25.2	26.9	22.5	23.0	24.6	26.3	22.0	22.5	24.0	25.7	20.9	21.3	22.8	24.4	19.3	19.8	21.1	22.6				
		850	S/T	1.00	1.00	1.00	1.00	1.00	1.00	1.00	1.00	1.00	1.00	1.00	1.00	1.00	1.00	1.00	1.00	1.00	1.00	1.00	1.00	1.00	1.00	1.00	1.00				
			Delta T	26	26	28	30	25	26	27	29	24	25	27	28	24	24	26	28	23	23	25	26	21	21	23	24				
750		KW	1.65	1.68	1.73	1.79	1.77	1.81	1.86	1.92	1.88	1.92	1.98	2.04	1.97	2.01	2.08	2.15	2.05	2.10	2.16	2.23	2.12	2.17	2.24	2.31					
		AMPS	7.2	7.3	7.5	7.7	7.6	7.8	8.0	8.3	8.2	8.4	8.6	8.9	8.7	8.8	9.1	9.4	9.1	9.3	9.6	9.9	9.6	9.8	10.1	10.4					
85		HI PR	220	237	250	261	247	266	281	293	281	303	320	333	320	345	364	380	360	388	410	427	398	428	452	472					
		LO PR	111	118	129	138	118	125	136	145	122	130	142	151	128	136	149	159	134	143	156	166	139	148	162	172					
86		950	MBh	22.5	22.9	24.5	26.2	21.9	22.4	23.9	25.6	21.4	21.9	23.4	25.0	20.9	21.3	22.8	24.4	19.8	20.3	21.7	23.2	18.4	18.8	20.1	21.4				
			S/T	1.00	1.00	1.00	1.00	1.00	1.00	1.00	1.00	1.00	1.00	1.00	1.00	1.00	1.00	1.00	1.00	1.00	1.00	1.00	1.00	1.00	1.00	1.00	1.00				
	850	Delta T	28	28	30	32	27	27	29	31	26	27	29	31	26	26	28	30	24	25	27	28	23	23	25	26					
		KW	1.63	1.66	1.71	1.76	1.74	1.78	1.83	1.89	1.85	1.89	1.95	2.01	1.94	1.98	2.04	2.11	2.02	2.06	2.13	2.20	2.09	2.13	2.20	2.27					
	750	AMPS	7.0	7.2	7.4	7.6	7.5	7.7	7.9	8.1	8.1	8.2	8.5	8.7	8.5	8.7	9.0	9.2	9.0	9.2	9.5	9.8	9.5	9.7	9.9	10.3					
		HI PR	216	232	245	256	242	261	275	287	276	297	313	327	314	338	357	372	353	380	401	419	390	420	443	462					
	86	LO PR	109	116	127	135	115	123	134	142	120	127	139	148	126	134	146	156	132	140	153	163	136	145	158	169					
		MBh	24.4	24.9	26.1	27.8	23.8	24.3	25.5	27.2	23.3	23.7	24.8	26.5	22.7	23.1	24.2	25.9	21.6	22.0	23.0	24.6	20.0	20.4	21.3	22.8					
	85	950	S/T	1.00	1.00	1.00	1.00	1.00	1.00	1.00	1.00	1.00	1.00	1.00	1.00	1.00	1.00	1.00	1.00	1.00	1.00	1.00	1.00	1.00	1.00	1.00					
			Delta T	24	24	25	27	23	24	25	26	23	23	24	26	22	22	23	25	21	21	22	24	19	20	21	22				
850		KW	1.67	1.71	1.76	1.81	1.79	1.83	1.89	1.95	1.90	1.94	2.00	2.07	2.00	2.04	2.11	2.17	2.08	2.13	2.19	2.27	2.15	2.20	2.27	2.34					
		AMPS	7.2	7.4	7.6	7.8	7.7	7.9	8.1	8.4	8.3	8.5	8.7	9.0	8.8	9.0	9.2	9.5	9.3	9.5	9.7	10.1	9.7	10.0	10.3	10.6					
750		HI PR	224	241	255	266	252	271	286	298	286	308	325	339	326	351	370	386	367	394	416	434	405	436	460	480					
		LO PR	113	120	131	140	120	127	139	148	124	132	144	154	130	139	152	161	137	145	159	169	141	150	164	175					
85		MBh	24.0	24.5	25.7	27.4	23.5	23.9	25.1	26.8	22.9	23.4	24.5	26.1	22.4	22.8	23.9	25.5	21.2	21.7	22.7	24.2	19.7	20.1	21.0	22.4					
		S/T	1.00	1.00	1.00	1.00	1.00	1.00	1.00	1.00	1.00	1.00	1.00	1.00	1.00	1.00	1.00	1.00	1.00	1.00	1.00	1.00	1.00	1.00	1.00	1.00					
85		950	Delta T	26	27	28	30	25	26	27	29	25	25	26	28	24	25	26	28	23	23	25	26	21	22	23	24				
			KW	1.66	1.70	1.75	1.80	1.79	1.82	1.88	1.94	1.89	1.93	1.99	2.06	1.99	2.03	2.09	2.16	2.07	2.11	2.18	2.25	2.14	2.19	2.26	2.33				
	850	AMPS	7.2	7.4	7.6	7.8	7.7	7.8	8.1	8.3	8.3	8.4	8.7	8.9	8.7	8.9	9.2	9.5	9.2	9.4	9.7	10.0	9.7	9.9	10.2	10.5					
		HI PR	223	240	253	264	250	269	284	296	284	306	323	337	324	348	368	383	364	392	414	431	402	433	457	477					
	750	LO PR	112	120	130	139	119	126	138	147	123	131	143	153	130	138	150	160	136	144	158	168	140	149	163	174					
		MBh	22.8	23.3	24.4	26.0	22.3	22.7	23.8	25.4	21.8	22.2	23.3	24.8	21.2	21.7	22.7	24.2	20.2	20.6	21.6	23.0	18.7	19.1	20.0	21.3					
	85	S/T	1.00	1.00	1.00	1.00	1.00	1.00	1.00	1.00	1.00	1.00	1.00	1.00	1.00	1.00	1.00	1.00	1.00	1.00	1.00	1.00	1.00	1.00	1.00	1.00					
		Delta T	28	29	30	32	27	28	29	31	27	27	29	30	26	27	28	30	25	25	26	28	23	23	24	26					
	85	KW	1.64	1.67	1.72	1.77	1.76	1.79	1.85	1.91	1.86	1.90	1.96	2.02	1.96	2.00	2.06	2.13	2.04	2.08	2.15	2.22	2.10	2.15	2.22	2.29					
		AMPS	7.1	7.2	7.4	7.7	7.6	7.7	7.9	8.2	8.1	8.3	8.5	8.8	8.6	8.8	9.1	9.3	9.1	9.3	9.5	9.8	9.5	9.7	10.0	10.4					
85	HI PR	218	235	248	259	245	263	278	290	278	300	316	330	317	341	360	376	357	384	405	423	394	424	448	467						
	LO PR	110	117	128	136	116	124	135	144	121	129	140	150	127	135	147	157	133	142	155	165	138	146	160	170						

NOTE: Shaded area reflects ARI rating conditions

* NOTE: Shaded areas is AHRI Rating Conditions
 IDB: Entering Indoor Dry Bulb Temperature
 High and low pressures are measured at the liquid and suction access fittings.
 KWh = Total system power
 AMPS: Unit amps (comp.+ evaporator + condenser fan motors)

MODEL: GPC1330H41A*

EXPANDED PERFORMANCE DATA

COOLING OPERATION

IDB*	Airflow	Outdoor Ambient Temperature																								
		75					85					95					105					115				
		59	63	67	71	75	59	63	67	71	75	59	63	67	71	75	59	63	67	71	75	59	63	67	71	75
70	MBh	27.8	28.8	31.6	-	27.2	28.2	30.9	-	26.5	27.5	30.1	-	25.9	26.8	29.4	-	24.6	25.5	27.9	-	22.8	23.6	25.9	-	
	S/T	0.74	0.62	0.43	-	0.77	0.64	0.44	-	0.79	0.66	0.46	-	0.81	0.68	0.47	-	0.84	0.70	0.49	-	0.85	0.71	0.49	-	
	Delta T	17	14	11	-	17	15	11	-	17	15	11	-	17	15	11	-	17	14	11	-	16	13	10	-	
	KW	1.75	1.78	1.84	-	1.89	1.93	1.99	-	2.01	2.05	2.12	-	2.12	2.16	2.24	-	2.21	2.26	2.34	-	2.29	2.34	2.42	-	
	AMPS	7.9	8.1	8.3	-	8.5	8.6	8.9	-	9.1	9.3	9.5	-	9.6	9.8	10.1	-	10.2	10.4	10.7	-	10.7	10.9	11.3	-	
	HI PR	234	252	266	-	263	283	299	-	299	322	340	-	341	367	387	-	383	412	435	-	423	456	481	-	
	LO PR	108	115	125	-	114	121	132	-	118	126	138	-	124	132	145	-	130	139	151	-	135	143	157	-	
	MBh	27.0	28.0	30.7	-	26.4	27.4	30.0	-	25.8	26.7	29.3	-	25.1	26.1	28.5	-	23.9	24.7	27.1	-	22.1	22.9	25.1	-	
	S/T	0.71	0.59	0.41	-	0.73	0.61	0.42	-	0.75	0.63	0.43	-	0.78	0.65	0.45	-	0.80	0.67	0.47	-	0.81	0.68	0.47	-	
	Delta T	17	15	11	-	17	15	11	-	17	15	11	-	18	15	12	-	17	15	11	-	16	14	11	-	
KW	1.73	1.77	1.83	-	1.87	1.91	1.97	-	1.99	2.04	2.10	-	2.10	2.15	2.22	-	2.19	2.24	2.32	-	2.27	2.32	2.40	-		
AMPS	7.9	8.0	8.2	-	8.4	8.6	8.8	-	9.0	9.2	9.5	-	9.5	9.8	10.0	-	10.1	10.3	10.6	-	10.6	10.8	11.2	-		
HI PR	232	250	264	-	260	280	296	-	296	319	336	-	337	363	383	-	379	408	431	-	419	451	476	-		
LO PR	107	114	124	-	113	120	131	-	117	125	136	-	123	131	143	-	129	137	150	-	134	142	155	-		
MBh	25.7	26.6	29.1	-	25.1	26.0	28.5	-	24.5	25.4	27.8	-	23.9	24.7	27.1	-	22.7	23.5	25.8	-	21.0	21.8	23.9	-		
S/T	0.68	0.57	0.39	-	0.70	0.59	0.41	-	0.72	0.60	0.42	-	0.74	0.62	0.43	-	0.77	0.64	0.45	-	0.78	0.65	0.45	-		
Delta T	18	15	12	-	18	16	12	-	18	16	12	-	18	16	12	-	18	15	12	-	17	14	11	-		
KW	1.70	1.74	1.80	-	1.84	1.88	1.94	-	1.96	2.00	2.07	-	2.06	2.11	2.18	-	2.15	2.20	2.28	-	2.23	2.28	2.36	-		
AMPS	7.7	7.9	8.1	-	8.3	8.4	8.7	-	8.9	9.1	9.3	-	9.4	9.6	9.9	-	9.9	10.1	10.4	-	10.4	10.7	11.0	-		
HI PR	227	245	258	-	255	275	290	-	290	312	330	-	330	356	376	-	372	400	422	-	411	442	467	-		
LO PR	105	111	122	-	111	118	128	-	115	122	133	-	121	128	140	-	127	135	147	-	131	139	152	-		
75	MBh	28.3	29.1	31.5	33.9	27.6	28.5	30.8	33.1	27.0	27.8	30.1	32.3	26.3	27.1	29.3	31.5	25.0	25.8	27.9	29.9	23.2	23.9	25.8	27.7	
	S/T	0.84	0.75	0.57	0.37	0.87	0.78	0.59	0.38	0.90	0.80	0.61	0.39	0.92	0.83	0.63	0.40	0.96	0.86	0.65	0.42	0.97	0.87	0.65	0.42	
	Delta T	19	18	14	10	19	18	15	10	19	18	15	10	20	18	15	10	19	18	15	10	18	17	14	9	
	KW	1.76	1.80	1.86	1.92	1.90	1.94	2.01	2.08	2.03	2.07	2.14	2.21	2.14	2.18	2.26	2.34	2.23	2.28	2.36	2.44	2.31	2.36	2.44	2.53	
	AMPS	8.0	8.1	8.4	8.6	8.5	8.7	9.0	9.2	9.2	9.4	9.6	9.9	9.7	9.9	10.2	10.5	10.2	10.5	10.8	11.1	10.8	11.0	11.3	11.7	
	HI PR	237	255	269	281	266	286	302	315	302	325	343	358	344	370	391	408	387	417	440	459	428	460	486	507	
	LO PR	109	116	127	135	115	122	134	142	120	127	139	148	126	134	146	155	132	140	153	163	136	145	158	169	
	MBh	27.5	28.3	30.6	32.9	26.8	27.6	29.9	32.1	26.2	27.0	29.2	31.3	25.6	26.3	28.5	30.6	24.3	25.0	27.1	29.0	22.5	23.2	25.1	26.9	
	S/T	0.80	0.72	0.54	0.35	0.83	0.74	0.56	0.36	0.85	0.76	0.58	0.37	0.88	0.79	0.60	0.38	0.91	0.82	0.62	0.40	0.92	0.83	0.62	0.40	
	Delta T	20	18	15	10	20	19	15	10	20	19	15	11	20	19	15	11	20	18	15	10	19	17	14	10	
KW	1.75	1.79	1.84	1.90	1.89	1.93	1.99	2.06	2.01	2.05	2.12	2.20	2.12	2.17	2.24	2.32	2.21	2.26	2.34	2.42	2.29	2.34	2.42	2.51		
AMPS	7.9	8.1	8.3	8.6	8.5	8.6	8.9	9.2	9.1	9.3	9.5	9.9	9.6	9.8	10.1	10.5	10.2	10.4	10.7	11.0	10.7	10.9	11.3	11.6		
HI PR	234	252	266	278	263	283	299	312	299	322	340	354	341	367	387	404	383	412	435	454	423	456	481	502		
LO PR	108	115	125	133	114	121	132	141	118	126	138	147	124	132	145	154	130	139	151	161	135	144	157	167		
MBh	26.1	26.9	29.1	31.2	25.5	26.3	28.4	30.5	24.9	25.6	27.7	29.8	24.3	25.0	27.1	29.0	23.1	23.8	25.7	27.6	21.4	22.0	23.8	25.6		
S/T	0.77	0.69	0.52	0.34	0.80	0.71	0.54	0.35	0.82	0.73	0.55	0.36	0.84	0.76	0.57	0.37	0.88	0.78	0.59	0.38	0.88	0.79	0.60	0.38		
Delta T	21	19	15	11	21	19	16	11	21	19	16	11	21	19	16	11	21	19	16	11	19	18	15	10		
KW	1.72	1.76	1.81	1.87	1.85	1.90	1.96	2.02	1.97	2.02	2.09	2.16	2.08	2.13	2.20	2.28	2.17	2.22	2.30	2.38	2.25	2.30	2.38	2.46		
AMPS	7.8	8.0	8.2	8.4	8.3	8.5	8.7	9.0	8.9	9.1	9.4	9.7	9.5	9.7	10.0	10.3	10.0	10.2	10.5	10.9	10.5	10.7	11.1	11.4		
HI PR	230	247	261	272	258	277	293	305	293	315	333	347	334	359	379	396	376	404	427	445	415	447	472	492		
LO PR	106	112	123	131	112	119	130	138	116	124	135	144	122	130	142	151	128	136	148	158	132	141	154	164		

* IDB: Entering Indoor Dry Bulb Temperature

High and low pressures are measured at the liquid and suction access fittings.

NOTE: Shaded area is ACCA (TVA) conditions

IDB*	Airflow	Outdoor Ambient Temperature																													
		65					75					85					95					105					115				
		59	63	67	71	75	59	63	67	71	75	59	63	67	71	75	59	63	67	71	75	59	63	67	71	75	59	63	67	71	75
80	1145	MBh	28.8	29.4	31.4	33.6	28.1	28.7	30.7	32.8	32.1	26.8	27.4	29.3	31.3	31.3	25.5	26.0	27.8	29.7	23.6	24.1	25.7	27.5							
		S/T	0.92	0.87	0.71	0.53	0.96	0.90	0.73	0.55	1.00	0.92	0.75	0.56	1.00	0.95	0.77	0.58	1.00	1.00	0.80	0.60	1.00	0.81							
		Delta T	21	20	18	14	22	21	18	14	14	22	21	18	15	20	21	18	15	14	19	19	17	13							
		KW	1.78	1.81	1.87	1.94	1.92	1.96	2.03	2.09	2.04	2.09	2.16	2.23	2.15	2.20	2.28	2.36	2.25	2.30	2.38	2.46	2.33	2.38							
		AMPS	8.0	8.2	8.4	8.7	8.6	8.8	9.0	9.3	9.2	9.4	9.7	10.0	9.8	10.0	10.3	10.6	10.3	10.6	10.9	11.2	10.9	11.1							
	1020	HI PR	239	257	272	283	268	289	305	318	305	328	347	362	348	374	395	412	391	421	444	463	432	465							
		LO PR	110	117	128	136	116	124	135	144	121	129	140	150	127	135	147	157	133	142	155	165	138	146							
		MBh	28.0	28.6	30.5	32.6	27.3	27.9	29.8	31.9	26.7	27.2	29.1	31.1	26.0	26.6	28.4	30.4	24.7	25.3	27.0	28.8	22.9	23.4							
		S/T	0.88	0.83	0.67	0.50	0.91	0.86	0.70	0.52	0.94	0.88	0.71	0.53	0.97	0.91	0.74	0.55	1.00	0.94	0.77	0.57	1.00	0.95							
		Delta T	22	21	19	15	22	22	19	15	23	22	19	15	23	22	19	15	22	21	19	15	21	20							
900	1145	KW	1.76	1.80	1.86	1.92	1.90	1.94	2.01	2.08	2.03	2.07	2.14	2.21	2.14	2.18	2.26	2.34	2.23	2.28	2.36	2.44	2.31	2.36							
		AMPS	8.0	8.1	8.4	8.6	8.5	8.7	9.0	9.2	9.2	9.4	9.6	9.9	9.7	9.9	10.2	10.5	10.2	10.5	10.8	11.1	10.8	11.0							
		HI PR	237	255	269	281	266	286	302	315	302	325	343	358	344	370	391	408	387	417	440	459	428	460							
		LO PR	109	116	127	135	115	123	134	142	120	127	139	148	126	134	146	155	132	140	153	163	136	145							
		MBh	26.6	27.1	29.0	31.0	25.9	26.5	28.3	30.3	25.3	25.9	27.7	29.6	24.7	25.3	27.0	28.8	23.5	24.0	25.6	27.4	21.7	22.2							
	1020	S/T	0.84	0.79	0.64	0.48	0.87	0.82	0.67	0.50	0.90	0.84	0.68	0.51	0.93	0.87	0.71	0.53	0.96	0.90	0.73	0.55	0.97	0.91							
		Delta T	23	22	19	15	23	22	19	15	23	22	19	15	23	22	19	16	23	22	19	15	22	21							
		KW	1.73	1.77	1.83	1.89	1.87	1.91	1.97	2.04	1.99	2.04	2.10	2.18	2.10	2.15	2.22	2.30	2.19	2.24	2.32	2.40	2.27	2.32							
		AMPS	7.9	8.0	8.2	8.5	8.4	8.6	8.8	9.1	9.0	9.2	9.5	9.8	9.5	9.8	10.0	10.4	10.1	10.3	10.6	11.0	10.6	10.8							
		HI PR	232	250	264	275	260	280	296	309	296	319	336	351	337	363	383	400	379	408	431	450	419	451							
LO PR	107	114	124	132	113	120	131	140	117	125	136	145	123	131	143	152	129	137	150	160	134	142									

NOTE: Shaded area reflects AHRI rating conditions

IDB*	Airflow	Outdoor Ambient Temperature																													
		65					75					85					95					105					115				
		59	63	67	71	75	59	63	67	71	75	59	63	67	71	75	59	63	67	71	75	59	63	67	71	75	59	63	67	71	75
85	1145	MBh	29.3	29.9	31.3	33.4	28.6	29.2	30.6	32.6	27.9	28.5	29.8	31.8	27.3	27.8	29.1	31.1	25.9	26.4	27.7	29.5	24.0	24.5							
		S/T	0.97	0.93	0.84	0.68	1.00	0.97	0.87	0.71	1.00	0.99	0.90	0.73	1.00	1.00	0.93	0.75	1.00	1.00	0.96	0.78	1.00	1.00							
		Delta T	23	22	21	18	23	23	21	19	22	23	21	19	22	22	22	19	21	21	21	18	19	20							
		KW	1.79	1.83	1.89	1.95	1.93	1.98	2.04	2.11	2.06	2.11	2.18	2.25	2.17	2.22	2.30	2.38	2.27	2.32	2.40	2.48	2.35	2.40							
		AMPS	8.1	8.3	8.5	8.8	8.7	8.8	9.1	9.4	9.3	9.5	9.8	10.1	9.9	10.1	10.4	10.7	10.4	10.6	11.0	11.3	11.0	11.2							
	1020	HI PR	241	260	274	286	271	292	308	321	308	332	350	365	351	378	399	416	395	425	449	468	436	470							
		LO PR	111	118	129	138	117	125	136	145	122	130	142	151	128	136	149	159	134	143	156	166	139	148							
		MBh	28.5	29.0	30.4	32.4	27.8	28.3	29.7	31.7	27.1	27.7	29.0	30.9	26.5	27.0	28.3	30.1	25.1	25.6	26.8	28.6	23.3	23.7							
		S/T	0.92	0.89	0.80	0.65	0.96	0.92	0.83	0.68	0.98	0.95	0.86	0.69	1.00	0.98	0.88	0.72	1.00	1.00	0.92	0.74	1.00	1.00							
		Delta T	24	23	22	19	24	24	22	19	24	24	22	19	24	24	22	19	23	23	22	19	21	21							
900	1145	KW	1.78	1.81	1.87	1.94	1.92	1.96	2.03	2.09	2.04	2.09	2.16	2.23	2.15	2.20	2.28	2.36	2.25	2.30	2.38	2.46	2.33	2.38							
		AMPS	8.0	8.2	8.4	8.7	8.6	8.8	9.0	9.3	9.2	9.4	9.7	10.0	9.8	10.0	10.3	10.6	10.3	10.6	10.9	11.2	10.9	11.1							
		HI PR	239	257	272	283	268	289	305	318	305	328	347	362	348	374	395	412	391	421	444	463	432	465							
		LO PR	110	117	128	136	116	124	135	144	121	129	140	150	127	135	147	157	133	142	155	165	138	146							
		MBh	27.0	27.6	28.9	30.8	26.4	26.9	28.2	30.1	25.8	26.3	27.5	29.4	25.1	25.6	26.8	28.6	23.9	24.4	25.5	27.2	22.1	22.6							
	1020	S/T	0.89	0.85	0.77	0.63	0.92	0.89	0.80	0.65	0.94	0.91	0.82	0.66	0.97	0.94	0.85	0.69	1.00	0.97	0.88	0.71	1.00	0.98							
		Delta T	24	24	23	20	25	24	23	20	25	24	23	20	25	25	23	20	24	24	23	20	23	23							
		KW	1.75	1.78	1.84	1.90	1.89	1.93	1.99	2.06	2.01	2.05	2.12	2.19	2.12	2.16	2.24	2.32	2.21	2.26	2.34	2.42	2.29	2.34							
		AMPS	7.9	8.1	8.3	8.6	8.5	8.6	8.9	9.2	9.1	9.3	9.5	9.9	9.6	9.8	10.1	10.5	10.2	10.4	10.7	11.0	10.7	10.9							
		HI PR	234	252	266	278	263	283	299	312	299	322	340	354	341	367	387	404	383	412	435	454	423	456							
LO PR	108	115	125	133	114	121	132	141	118	126	138	147	124	132	145	154	130	139	151	161	135	143									

* NOTE: Shaded areas is AHRI Rating Conditions

IDB: Entering Indoor Dry Bulb Temperature

KW = Total system power

AMPS: Unit amps (comp.+ evaporator + condenser fan motors)

IDB*	Airflow	Outdoor Ambient Temperature																									
		65				75				85				95				105				115					
		59	63	67	71	59	63	67	71	59	63	67	71	59	63	67	71	59	63	67	71	59	63	67	71		
80	1350	MBh	35.7	36.5	39.0	41.7	34.9	35.6	38.1	40.7	34.0	34.8	37.2	39.7	33.2	33.9	36.3	38.8	31.5	32.2	34.4	36.8	29.2	29.9	31.9	34.1	
		ST	0.93	0.87	0.71	0.53	0.96	0.90	0.73	0.55	1.00	0.92	0.75	0.56	1.00	0.95	0.78	0.58	1.00	1.00	0.81	0.60	1.00	1.00	0.81	0.61	
		Delta T	23	22	19	15	23	22	19	15	23	22	19	15	23	22	19	15	23	21	22	19	15	20	20	18	14
		KW	2.57	2.63	2.71	2.79	2.77	2.82	2.91	3.00	2.93	3.00	3.09	3.19	3.08	3.15	3.25	3.36	3.21	3.28	3.39	3.50	3.32	3.39	3.50	3.62	
		AMPS	11.1	11.3	11.6	12.0	11.8	12.1	12.4	12.8	12.7	12.9	13.3	13.7	13.4	13.7	14.1	14.6	14.2	14.5	14.9	15.4	14.9	15.2	15.7	16.2	
		HI PR	246	265	280	292	276	297	314	327	314	338	357	372	358	385	407	424	403	433	458	477	445	479	505	527	
		LO PR	110	117	128	136	116	124	135	144	121	128	140	149	127	135	147	157	133	141	154	164	137	146	160	170	
		MBh	34.7	35.4	37.8	40.5	33.9	34.6	37.0	39.5	33.0	33.8	36.1	38.6	32.2	32.9	35.2	37.6	30.6	31.3	33.4	35.7	28.4	29.0	31.0	33.1	
		ST	0.88	0.83	0.67	0.50	0.92	0.86	0.70	0.52	0.94	0.88	0.72	0.54	0.97	0.91	0.74	0.55	1.00	0.94	0.77	0.57	1.00	0.95	0.77	0.58	
		Delta T	23	22	20	16	24	23	20	16	24	23	20	16	24	23	20	16	24	23	23	20	16	22	21	18	15
KW	2.55	2.61	2.69	2.77	2.74	2.80	2.89	2.98	2.91	2.97	3.07	3.17	3.06	3.12	3.22	3.33	3.18	3.25	3.36	3.47	3.29	3.36	3.47	3.59			
AMPS	11.0	11.2	11.5	11.9	11.7	12.0	12.3	12.7	12.6	12.8	13.2	13.6	13.3	13.6	14.0	14.4	14.1	14.4	14.8	15.3	14.8	15.1	15.5	16.1			
HI PR	244	262	277	289	274	294	311	324	311	335	354	369	354	381	403	420	399	429	453	472	440	474	500	522			
LO PR	109	116	126	135	115	122	134	142	120	127	139	148	126	134	146	155	132	140	153	163	136	145	158	168			
MBh	32.0	32.7	34.9	37.3	31.2	31.9	34.1	36.5	30.5	31.2	33.3	35.6	29.8	30.4	32.5	34.7	28.3	28.9	30.9	33.0	26.2	26.8	28.6	30.6			
ST	0.85	0.80	0.65	0.49	0.88	0.83	0.67	0.50	0.91	0.85	0.69	0.52	0.93	0.88	0.71	0.53	0.97	0.91	0.74	0.55	0.98	0.92	0.75	0.56			
Delta T	24	23	20	16	24	23	20	16	24	23	20	16	24	23	20	16	24	23	23	20	16	22	21	19	15		
KW	2.50	2.55	2.62	2.70	2.68	2.73	2.82	2.91	2.84	2.90	2.99	3.09	2.98	3.05	3.15	3.25	3.11	3.17	3.28	3.38	3.21	3.28	3.39	3.50			
AMPS	10.7	11.0	11.3	11.6	11.5	11.7	12.0	12.4	12.3	12.5	12.9	13.3	13.0	13.3	13.7	14.1	13.7	14.0	14.4	14.9	14.4	14.7	15.2	15.7			
HI PR	236	254	269	280	265	286	302	314	302	325	343	358	344	370	391	407	387	416	439	458	427	460	485	506			
LO PR	106	112	123	131	112	119	130	138	116	123	135	143	122	130	141	151	128	136	148	158	132	140	153	163			
85	1350	MBh	36.3	37.0	38.8	41.4	35.5	36.2	37.9	40.4	34.6	35.3	37.0	39.4	33.8	34.4	36.1	38.5	32.1	32.7	34.3	36.6	29.7	30.3	31.7	33.9	
		ST	0.97	0.94	0.85	0.69	1.00	0.97	0.88	0.71	1.00	1.00	0.90	0.73	1.00	1.00	0.93	0.75	1.00	1.00	0.96	0.78	1.00	1.00	0.97	0.79	
		Delta T	24	24	22	19	24	24	23	20	24	24	23	20	23	23	23	20	23	22	22	19	20	21	21	18	
		KW	2.59	2.65	2.73	2.81	2.79	2.85	2.93	3.03	2.96	3.02	3.12	3.22	3.11	3.18	3.28	3.38	3.24	3.31	3.41	3.53	3.35	3.42	3.53	3.65	
		AMPS	11.2	11.4	11.7	12.1	11.9	12.2	12.5	12.9	12.8	13.0	13.4	13.9	13.5	13.8	14.2	14.7	14.3	14.6	15.0	15.5	15.0	15.3	15.8	16.3	
		HI PR	249	268	283	295	279	300	317	331	317	342	361	376	361	389	411	428	407	438	462	482	449	483	511	533	
		LO PR	111	118	129	137	117	125	136	145	122	130	142	151	128	136	149	158	134	143	156	166	139	148	161	172	
		MBh	35.3	35.9	37.7	40.2	34.4	35.1	36.8	39.2	33.6	34.3	35.9	38.3	32.8	33.4	35.0	37.4	31.2	31.8	33.3	35.5	28.9	29.4	30.8	32.9	
		ST	0.93	0.89	0.81	0.65	0.96	0.93	0.84	0.68	0.98	0.95	0.86	0.70	1.00	0.98	0.89	0.72	1.00	1.00	0.92	0.75	1.00	1.00	0.93	0.75	
		Delta T	25	25	23	20	25	25	24	20	25	25	24	20	25	25	24	21	24	24	24	23	20	22	23	22	19
KW	2.57	2.63	2.71	2.79	2.77	2.82	2.91	3.00	2.93	3.00	3.09	3.19	3.08	3.15	3.25	3.36	3.21	3.28	3.39	3.50	3.32	3.39	3.50	3.62			
AMPS	11.1	11.3	11.6	12.0	11.8	12.1	12.4	12.8	12.7	12.9	13.3	13.7	13.4	13.7	14.1	14.6	14.2	14.5	14.9	15.4	14.9	15.2	15.7	16.2			
HI PR	246	265	280	292	276	297	314	327	314	338	357	372	358	385	407	424	403	433	458	477	445	479	505	527			
LO PR	110	117	128	136	116	124	135	144	121	128	140	149	127	135	147	157	133	141	154	164	137	146	160	170			
MBh	32.6	33.2	34.8	37.1	31.8	32.4	33.9	36.2	31.0	31.6	33.1	35.4	30.3	30.9	32.3	34.5	28.8	29.3	30.7	32.8	26.6	27.2	28.4	30.3			
ST	0.89	0.86	0.78	0.63	0.93	0.89	0.81	0.65	0.95	0.92	0.83	0.67	0.98	0.95	0.85	0.69	1.00	0.98	0.89	0.72	1.00	0.99	0.89	0.72			
Delta T	25	25	24	20	26	25	24	21	26	25	24	21	26	26	24	21	25	25	24	21	23	24	22	19			
KW	2.51	2.57	2.64	2.73	2.70	2.76	2.84	2.93	2.86	2.92	3.02	3.11	3.01	3.07	3.17	3.27	3.13	3.20	3.30	3.41	3.24	3.31	3.42	3.53			
AMPS	10.8	11.0	11.3	11.7	11.5	11.8	12.1	12.5	12.4	12.6	13.0	13.4	13.1	13.4	13.8	14.2	13.8	14.1	14.5	15.0	14.5	14.8	15.3	15.8			
HI PR	239	257	271	283	268	288	305	318	305	328	346	361	347	374	394	411	391	420	444	463	431	464	490	511			
LO PR	107	113	124	132	113	120	131	139	117	125	136	145	123	131	143	152	129	137	150	159	133	142	155	165			

* NOTE: Shaded areas is A-HRI Rating Conditions IDB: Entering Indoor Dry Bulb Temperature KW = Total system power
 High and low pressures are measured at the liquid and suction access fittings. AMPS: Unit amps (comp.+ evaporator + condenser fan motors)

COOLING PERFORMANCE DATA

5MM COILS

GPC1342H41AB

EXPANDED PERFORMANCE DATA

EXPANDED PERFORMANCE DATA

MODEL: GPC1342H41A*

IDB*	Airflow	Outdoor Ambient Temperature																							
		65				75				85				95				105				115			
		59	63	67	71	59	63	67	71	59	63	67	71	59	63	67	71	59	63	67	71	59	63	67	71
70	MBh	40.2	41.6	45.6	-	39.2	40.7	44.6	-	38.3	39.7	43.5	-	37.4	38.7	42.4	-	35.5	36.8	40.3	-	32.9	34.1	37.3	-
	ST	0.77	0.65	0.45	-	0.80	0.67	0.46	-	0.82	0.69	0.48	-	0.85	0.71	0.49	-	0.88	0.74	0.51	-	0.89	0.74	0.51	-
	Delta T	18	16	12	-	18	16	12	-	18	16	12	-	18	16	12	-	18	16	12	-	17	15	11	-
	KW	2.77	2.83	2.91	-	2.97	3.03	3.12	-	3.14	3.20	3.30	-	3.29	3.36	3.46	-	3.42	3.49	3.60	-	3.53	3.60	3.72	-
	AMPS	12.3	12.5	12.9	-	13.1	13.4	13.7	-	14.0	14.3	14.7	-	14.8	15.1	15.6	-	15.6	16.0	16.4	-	16.4	16.8	17.3	-
	HI PR	225	242	256	-	252	272	287	-	287	309	326	-	327	352	372	-	368	396	418	-	406	437	462	-
	LO PR	110	117	128	-	117	124	135	-	121	129	141	-	127	135	148	-	133	142	155	-	138	147	160	-
	MBh	39.0	40.4	44.3	-	38.1	39.5	43.3	-	37.2	38.5	42.2	-	36.3	37.6	41.2	-	34.5	35.7	39.1	-	31.9	33.1	36.3	-
	ST	0.74	0.62	0.43	-	0.77	0.64	0.44	-	0.78	0.66	0.45	-	0.81	0.68	0.47	-	0.84	0.70	0.49	-	0.85	0.71	0.49	-
	Delta T	19	16	12	-	19	16	12	-	19	16	12	-	19	17	13	-	19	16	12	-	18	15	12	-
KW	2.75	2.81	2.89	-	2.95	3.00	3.09	-	3.12	3.18	3.27	-	3.27	3.33	3.43	-	3.39	3.46	3.57	-	3.50	3.58	3.69	-	
AMPS	12.2	12.5	12.8	-	13.0	13.3	13.6	-	13.9	14.2	14.6	-	14.7	15.0	15.4	-	15.5	15.8	16.3	-	16.3	16.6	17.1	-	
HI PR	223	240	253	-	250	269	284	-	284	306	323	-	324	348	368	-	364	392	414	-	402	433	457	-	
LO PR	109	116	127	-	115	123	134	-	120	128	139	-	126	134	146	-	132	140	153	-	137	145	159	-	
MBh	36.0	37.3	40.9	-	35.2	36.4	39.9	-	34.3	35.6	39.0	-	33.5	34.7	38.0	-	31.8	33.0	36.1	-	29.5	30.5	33.5	-	
ST	0.71	0.59	0.41	-	0.74	0.62	0.43	-	0.76	0.63	0.44	-	0.78	0.65	0.45	-	0.81	0.68	0.47	-	0.82	0.68	0.47	-	
Delta T	19	16	12	-	19	17	13	-	19	17	13	-	19	17	13	-	19	17	13	-	18	15	12	-	
KW	2.69	2.74	2.82	-	2.88	2.94	3.02	-	3.04	3.11	3.20	-	3.19	3.25	3.35	-	3.31	3.38	3.49	-	3.42	3.49	3.60	-	
AMPS	12.0	12.2	12.5	-	12.7	13.0	13.3	-	13.6	13.9	14.3	-	14.4	14.7	15.1	-	15.2	15.5	15.9	-	15.9	16.2	16.7	-	
HI PR	216	233	246	-	242	261	275	-	276	297	313	-	314	338	357	-	353	380	401	-	390	420	444	-	
LO PR	106	113	123	-	112	119	130	-	116	124	135	-	122	130	142	-	128	136	149	-	132	141	154	-	

IDB*	Airflow	Outdoor Ambient Temperature																							
		65				75				85				95				105				115			
		59	63	67	71	59	63	67	71	59	63	67	71	59	63	67	71	59	63	67	71	59	63	67	71
75	MBh	40.9	42.1	45.5	48.9	39.9	41.1	44.5	47.7	39.0	40.1	43.4	46.6	38.0	39.1	42.4	45.5	36.1	37.2	40.2	43.2	33.4	34.4	37.3	40.0
	ST	0.88	0.79	0.60	0.38	0.91	0.82	0.62	0.40	0.94	0.84	0.63	0.41	0.97	0.86	0.65	0.42	1.00	0.90	0.68	0.44	1.00	0.90	0.68	0.44
	Delta T	21	19	16	11	21	20	16	11	21	20	16	11	21	20	16	11	21	19	16	11	19	18	15	10
	KW	2.79	2.85	2.93	3.02	2.99	3.05	3.14	3.23	3.16	3.23	3.32	3.43	3.32	3.38	3.49	3.60	3.45	3.52	3.63	3.74	3.56	3.63	3.75	3.87
	AMPS	12.4	12.6	13.0	13.4	13.2	13.5	13.8	14.3	14.1	14.4	14.8	15.3	15.0	15.3	15.7	16.2	15.8	16.1	16.5	17.1	16.6	16.9	17.4	18.0
	HI PR	227	245	258	269	255	274	290	302	290	312	330	344	330	355	375	392	372	400	422	440	411	442	467	487
	LO PR	111	119	129	138	118	125	137	146	122	130	142	151	128	137	149	159	135	143	156	167	139	148	162	172
	MBh	39.7	40.8	44.2	47.4	38.7	39.9	43.2	46.3	37.8	38.9	42.2	45.2	36.9	38.0	41.1	44.1	35.1	36.1	39.1	41.9	32.5	33.4	36.2	38.8
	ST	0.84	0.75	0.57	0.37	0.87	0.78	0.59	0.38	0.89	0.80	0.60	0.39	0.92	0.82	0.62	0.40	0.96	0.85	0.65	0.42	0.96	0.86	0.65	0.42
	Delta T	22	20	16	11	22	20	17	11	22	20	17	11	22	20	17	12	22	20	16	11	20	19	15	11
KW	2.77	2.83	2.91	2.99	2.97	3.03	3.12	3.21	3.14	3.20	3.30	3.40	3.29	3.36	3.46	3.57	3.42	3.49	3.60	3.71	3.53	3.60	3.72	3.84	
AMPS	12.3	12.6	12.9	13.3	13.1	13.4	13.7	14.2	14.0	14.3	14.7	15.2	14.8	15.1	15.6	16.1	15.6	16.0	16.4	17.0	16.4	16.8	17.3	17.8	
HI PR	225	242	256	267	252	272	287	299	287	309	326	340	327	352	372	388	368	396	418	436	407	437	462	482	
LO PR	110	117	128	136	117	124	135	144	121	129	141	150	127	135	148	157	133	142	155	165	138	147	160	171	
MBh	36.6	37.7	40.8	43.8	35.8	36.8	39.9	42.8	34.9	35.9	38.9	41.8	34.1	35.1	38.0	40.7	32.4	33.3	36.1	38.7	30.0	30.9	33.4	35.8	
ST	0.81	0.72	0.55	0.35	0.84	0.75	0.57	0.37	0.86	0.77	0.58	0.37	0.89	0.79	0.60	0.39	0.92	0.82	0.62	0.40	0.93	0.83	0.63	0.40	
Delta T	22	20	17	11	22	20	17	12	22	20	17	12	22	21	17	12	22	20	17	12	21	19	16	11	
KW	2.71	2.76	2.84	2.93	2.90	2.96	3.04	3.14	3.07	3.13	3.22	3.32	3.22	3.28	3.38	3.48	3.34	3.41	3.51	3.62	3.45	3.52	3.63	3.74	
AMPS	12.0	12.3	12.6	13.0	12.8	13.1	13.4	13.8	13.7	14.0	14.4	14.8	14.5	14.8	15.2	15.7	15.3	15.6	16.0	16.5	16.0	16.4	16.8	17.4	
HI PR	218	235	248	259	245	264	278	290	279	300	317	330	317	341	360	376	357	384	406	423	394	424	448	467	
LO PR	107	114	124	132	113	120	131	140	117	125	136	145	123	131	143	153	129	138	150	160	134	142	155	165	

* IDB: Entering Indoor Dry Bulb Temperature

NOTE: Shaded area is ACCA (TVA) conditions
High and low pressures are measured at the liquid and suction access fittings.

IDB*	Airflow	Outdoor Ambient Temperature																													
		65					75					85					95					105					115				
		59	63	67	71	75	59	63	67	71	75	59	63	67	71	75	59	63	67	71	75	59	63	67	71	75	59	63	67	71	75
80	1580	MBh	41.6	42.5	45.4	48.5	40.6	41.5	44.3	47.4	39.6	40.5	43.3	46.3	38.7	39.5	42.2	45.1	36.7	37.6	40.1	42.9	34.0	34.8	37.2	39.7					
		S/T	0.97	0.91	0.74	0.55	1.00	0.94	0.76	0.57	1.00	0.96	0.78	0.59	1.00	1.00	0.81	0.60	1.00	1.00	0.84	0.63	1.00	1.00	0.85	0.63					
		Delta T	23	22	19	16	24	23	20	16	23	23	20	16	23	23	20	16	21	22	20	16	20	20	18	15					
		KW	2.81	2.87	2.95	3.04	3.01	3.07	3.16	3.26	3.19	3.25	3.35	3.45	3.34	3.41	3.52	3.63	3.47	3.55	3.66	3.77	3.59	3.66	3.78	3.90					
		AMPS	12.5	12.7	13.1	13.5	13.3	13.6	13.9	14.4	14.3	14.5	14.9	15.4	15.1	15.4	15.8	16.3	15.9	16.2	16.7	17.2	16.7	17.0	17.5	18.1					
	1410	HI PR	230	247	261	272	258	277	293	305	293	315	333	347	334	359	379	395	375	404	427	445	415	446	471	492					
		LO PR	113	120	131	139	119	126	138	147	124	131	144	153	130	138	151	161	136	145	158	168	141	150	163	174					
		MBh	40.4	41.3	44.1	47.1	39.4	40.3	43.1	46.0	38.5	39.3	42.0	44.9	37.6	38.4	41.0	43.8	35.7	36.5	39.0	41.6	33.0	33.8	36.1	38.6					
		S/T	0.92	0.86	0.70	0.53	0.95	0.89	0.73	0.54	0.98	0.92	0.75	0.56	1.00	0.95	0.77	0.58	1.00	0.98	0.80	0.60	1.00	0.99	0.81	0.60					
		Delta T	24	23	20	16	25	24	20	16	25	24	20	16	24	24	21	16	22	23	20	16	22	22	19	15					
1240	KW	2.79	2.85	2.93	3.02	2.99	3.05	3.14	3.23	3.16	3.23	3.32	3.43	3.32	3.38	3.49	3.60	3.45	3.52	3.63	3.74	3.56	3.63	3.75	3.87						
	AMPS	12.4	12.6	13.0	13.4	13.2	13.5	13.8	14.3	14.1	14.4	14.8	15.3	15.0	15.3	15.7	16.2	15.8	16.1	16.5	17.1	16.6	16.9	17.4	18.0						
	HI PR	227	245	258	269	255	274	290	302	290	312	330	344	330	356	375	392	372	400	422	440	411	442	467	487						
	LO PR	111	119	129	138	118	125	137	146	122	130	142	151	129	137	149	159	135	143	156	167	139	148	162	172						
	MBh	37.3	38.1	40.7	43.5	36.4	37.2	39.7	42.5	35.5	36.3	38.8	41.5	34.7	35.4	37.8	40.5	32.9	33.6	36.0	38.4	30.5	31.2	33.3	35.6						
85	1580	S/T	0.89	0.83	0.68	0.51	0.92	0.86	0.70	0.52	0.94	0.88	0.72	0.54	0.97	0.91	0.74	0.56	1.01	0.95	0.77	0.58	1.02	0.96	0.78	0.58					
		Delta T	25	23	20	16	25	24	21	17	25	24	21	17	25	24	21	17	23	24	21	16	23	22	19	15					
		KW	2.73	2.78	2.86	2.95	2.92	2.98	3.07	3.16	3.09	3.15	3.25	3.35	3.24	3.31	3.41	3.51	3.37	3.44	3.54	3.65	3.48	3.55	3.66	3.77					
		AMPS	12.1	12.4	12.7	13.1	12.9	13.2	13.5	13.9	13.8	14.1	14.5	14.9	14.6	14.9	15.3	15.8	15.4	15.7	16.2	16.7	16.2	16.5	17.0	17.5					
		HI PR	220	237	251	261	247	266	281	293	281	303	320	333	320	345	364	380	360	388	410	427	398	429	453	472					
	1410	LO PR	108	115	126	134	114	121	133	141	119	126	138	147	125	133	145	154	131	139	152	162	135	144	157	167					
		MBh	42.3	43.1	45.2	48.2	41.3	42.1	44.1	47.1	40.3	41.1	43.1	45.9	39.4	40.1	42.0	44.8	37.4	38.1	39.9	42.6	34.6	35.3	37.0	39.4					
		S/T	1.00	0.98	0.88	0.71	1.00	1.00	0.91	0.74	1.00	1.00	0.94	0.76	1.00	1.00	0.97	0.78	1.00	1.00	1.00	0.81	1.00	1.00	1.00	0.82					
		Delta T	25	24	23	20	24	25	23	20	23	24	23	20	23	23	24	20	22	22	23	20	20	21	22	19					
		KW	2.83	2.89	2.97	3.06	3.03	3.09	3.19	3.28	3.21	3.28	3.38	3.48	3.37	3.44	3.54	3.65	3.50	3.57	3.68	3.80	3.62	3.69	3.81	3.93					
85	1580	AMPS	12.6	12.8	13.2	13.6	13.4	13.7	14.0	14.5	14.4	14.7	15.1	15.5	15.2	15.5	15.9	16.4	16.0	16.3	16.8	17.4	16.8	17.2	17.7	18.3					
		HI PR	232	250	263	275	260	280	296	308	296	318	336	351	337	363	383	399	379	408	431	449	419	451	476	496					
		LO PR	114	121	132	141	120	128	139	149	125	133	145	154	131	139	152	162	137	146	160	170	142	151	165	176					
		MBh	41.1	41.9	43.9	46.8	40.1	40.9	42.8	45.7	39.2	39.9	41.8	44.6	38.2	39.0	40.8	43.5	36.3	37.0	38.8	41.3	33.6	34.3	35.9	38.3					
		S/T	0.96	0.93	0.84	0.68	1.00	0.96	0.87	0.71	1.00	0.99	0.89	0.72	1.00	1.00	0.92	0.75	1.00	1.00	0.96	0.78	1.00	1.00	0.96	0.78					
	1410	Delta T	26	25	24	21	26	26	24	21	26	26	24	21	25	25	25	21	24	24	24	21	22	22	23	20					
		KW	2.81	2.87	2.95	3.04	3.01	3.07	3.16	3.26	3.19	3.25	3.35	3.45	3.34	3.41	3.52	3.63	3.47	3.55	3.66	3.77	3.59	3.66	3.78	3.90					
		AMPS	12.5	12.7	13.1	13.5	13.3	13.6	13.9	14.4	14.3	14.5	14.9	15.4	15.1	15.4	15.8	16.3	15.9	16.2	16.7	17.2	16.7	17.0	17.5	18.1					
		HI PR	230	247	261	272	258	277	293	305	293	315	333	347	334	359	379	395	375	404	427	445	415	446	471	492					
		LO PR	113	120	131	139	119	126	138	147	124	131	144	153	130	138	151	161	136	145	158	168	141	150	163	174					
1240	MBh	37.9	38.6	40.5	43.2	37.0	37.7	39.5	42.2	36.2	36.9	38.6	41.2	35.3	36.0	37.7	40.2	33.5	34.2	35.8	38.2	31.0	31.6	33.1	35.4						
	S/T	0.93	0.90	0.81	0.66	0.96	0.93	0.84	0.68	0.99	0.95	0.86	0.70	1.00	0.98	0.89	0.72	1.00	1.00	0.92	0.75	1.00	1.00	0.93	0.75						
	Delta T	26	26	24	21	26	26	25	21	27	26	25	21	26	26	25	21	25	25	24	21	23	23	23	20						
	KW	2.75	2.80	2.89	2.97	2.94	3.00	3.09	3.18	3.11	3.18	3.27	3.37	3.26	3.33	3.43	3.54	3.39	3.46	3.57	3.68	3.50	3.58	3.69	3.80						
	AMPS	12.2	12.5	12.8	13.2	13.0	13.3	13.6	14.0	13.9	14.2	14.6	15.1	14.7	15.0	15.4	15.9	15.5	15.8	16.3	16.8	16.3	16.6	17.1	17.7						
1240	HI PR	223	240	253	264	250	269	284	296	284	306	323	337	324	348	368	384	364	392	414	432	402	433	457	477						
	LO PR	109	116	127	135	115	123	134	143	120	128	139	148	126	134	146	156	132	140	153	163	136	145	159	169						

* NOTE: Shaded areas is AHRI Rating Conditions IDB: Entering Indoor Dry Bulb Temperature KW = Total system power

COOLING PERFORMANCE DATA

5MM COILS

GPC1349H41AA

EXPANDED PERFORMANCE DATA

MODEL: GPC1349H41A*

COOLING OPERATION

IDB*	Airflow	Outdoor Ambient Temperature																								
		65				75				85				95				105				115				
		59	63	67	71	59	63	67	71	59	63	67	71	59	63	67	71	59	63	67	71	59	63	67	71	
70	1800	MBh	44.6	46.2	50.6	-	43.5	45.1	49.5	-	42.5	44.1	48.3	-	41.5	43.0	47.1	-	39.4	40.8	44.7	-	36.5	37.8	41.4	-
		S/T	0.77	0.64	0.44	-	0.79	0.66	0.46	-	0.81	0.68	0.47	-	0.84	0.70	0.49	-	0.87	0.73	0.50	-	0.88	0.73	0.51	-
		Delta T	17	15	11	-	18	15	12	-	18	15	12	-	18	15	12	-	18	15	12	-	16	14	11	-
		KW	3.20	3.27	3.36	-	3.43	3.49	3.60	-	3.62	3.70	3.81	-	3.80	3.87	3.99	-	3.95	4.03	4.15	-	4.07	4.16	4.29	-
		AMPS	13.9	14.2	14.5	-	14.8	15.1	15.5	-	15.9	16.2	16.6	-	16.8	17.1	17.6	-	17.7	18.0	18.5	-	18.5	18.9	19.5	-
		HI PR	234	252	266	-	262	282	298	-	298	321	339	-	340	366	386	-	382	411	434	-	422	454	480	-
		LO PR	112	119	130	-	118	125	137	-	123	130	142	-	129	137	149	-	135	143	157	-	139	148	162	-
		MBh	43.3	44.9	49.2	-	42.3	43.8	48.0	-	41.3	42.8	46.9	-	40.3	41.7	45.7	-	38.3	39.6	43.4	-	35.4	36.7	40.2	-
		S/T	0.73	0.61	0.42	-	0.76	0.63	0.44	-	0.78	0.65	0.45	-	0.80	0.67	0.46	-	0.83	0.69	0.48	-	0.84	0.70	0.49	-
		Delta T	18	16	12	-	18	16	12	-	18	16	12	-	19	16	12	-	18	16	12	-	17	15	11	-
70	1600	KW	3.18	3.24	3.34	-	3.40	3.47	3.57	-	3.60	3.67	3.78	-	3.77	3.85	3.96	-	3.92	4.00	4.12	-	4.04	4.12	4.25	-
		AMPS	13.8	14.1	14.4	-	14.7	15.0	15.4	-	15.7	16.0	16.5	-	16.6	17.0	17.4	-	17.5	17.9	18.4	-	18.4	18.8	19.3	-
		HI PR	231	249	263	-	260	279	295	-	295	318	336	-	336	362	382	-	378	407	430	-	418	450	475	-
		LO PR	110	118	128	-	117	124	136	-	121	129	141	-	127	136	148	-	134	142	155	-	138	147	160	-
		MBh	40.0	41.4	45.4	-	39.0	40.4	44.3	-	38.1	39.5	43.3	-	37.2	38.5	42.2	-	35.3	36.6	40.1	-	32.7	33.9	37.1	-
		S/T	0.70	0.59	0.41	-	0.73	0.61	0.42	-	0.75	0.63	0.43	-	0.77	0.65	0.45	-	0.80	0.67	0.46	-	0.81	0.68	0.47	-
		Delta T	18	16	12	-	19	16	12	-	19	16	12	-	19	16	12	-	19	16	12	-	17	15	11	-
		KW	3.11	3.17	3.26	-	3.33	3.39	3.49	-	3.52	3.59	3.69	-	3.68	3.76	3.87	-	3.82	3.90	4.02	-	3.95	4.03	4.15	-
		AMPS	13.5	13.8	14.1	-	14.4	14.7	15.0	-	15.4	15.7	16.1	-	16.2	16.6	17.0	-	17.1	17.5	18.0	-	18.0	18.3	18.9	-
		HI PR	224	242	255	-	252	271	286	-	286	308	326	-	326	351	371	-	367	395	417	-	406	436	461	-
LO PR	107	114	124	-	113	120	131	-	118	125	137	-	124	131	144	-	130	138	150	-	134	143	156	-		
75	1800	MBh	45.3	46.7	50.5	54.2	44.3	45.6	49.4	53.0	43.2	44.5	48.2	51.7	42.2	43.4	47.0	50.4	40.1	41.3	44.7	47.9	37.1	38.2	41.4	44.4
		S/T	0.87	0.78	0.59	0.38	0.90	0.81	0.61	0.39	0.93	0.83	0.63	0.40	0.96	0.85	0.65	0.42	0.99	0.89	0.67	0.43	1.00	0.89	0.68	0.44
		Delta T	20	19	15	11	20	19	15	11	20	19	15	11	21	19	16	11	20	19	15	11	19	17	14	10
		KW	3.23	3.29	3.38	3.48	3.45	3.52	3.62	3.73	3.65	3.73	3.84	3.95	3.83	3.91	4.02	4.15	3.98	4.06	4.18	4.31	4.10	4.19	4.32	4.46
		AMPS	14.0	14.3	14.7	15.1	14.9	15.2	15.6	16.1	16.0	16.3	16.7	17.3	16.9	17.2	17.7	18.3	17.8	18.2	18.7	19.3	18.7	19.1	19.6	20.3
		HI PR	236	254	268	280	265	285	301	314	301	324	342	357	343	369	390	407	386	415	439	458	427	459	485	506
		LO PR	113	120	131	139	119	127	138	147	124	132	144	153	130	138	151	161	136	145	158	169	141	150	164	174
		MBh	44.0	45.3	49.1	52.7	43.0	44.3	47.9	51.4	42.0	43.2	46.8	50.2	41.0	42.2	45.6	49.0	38.9	40.1	43.4	46.5	36.0	37.1	40.2	43.1
		S/T	0.83	0.74	0.56	0.36	0.86	0.77	0.58	0.37	0.88	0.79	0.60	0.38	0.91	0.82	0.62	0.40	0.95	0.85	0.64	0.41	0.95	0.85	0.65	0.42
		Delta T	21	19	16	11	21	20	16	11	21	20	16	11	21	20	16	11	21	19	16	11	20	18	15	10
75	1600	KW	3.21	3.27	3.36	3.46	3.43	3.50	3.60	3.71	3.62	3.70	3.81	3.92	3.80	3.88	3.99	4.12	3.95	4.03	4.15	4.28	4.07	4.16	4.29	4.42
		AMPS	13.9	14.2	14.5	15.0	14.8	15.1	15.5	16.0	15.9	16.2	16.6	17.1	16.8	17.1	17.6	18.1	17.7	18.0	18.5	19.1	18.5	18.9	19.5	20.1
		HI PR	234	252	266	277	262	282	298	311	298	321	339	354	340	366	386	403	382	411	434	453	422	454	480	501
		LO PR	112	119	130	138	118	125	137	146	123	130	142	152	129	137	149	159	135	144	157	167	140	148	162	173
		MBh	40.6	41.8	45.3	48.6	39.7	40.9	44.2	47.5	38.7	39.9	43.2	46.3	37.8	38.9	42.1	45.2	35.9	37.0	40.0	42.9	33.3	34.2	37.1	39.8
		S/T	0.80	0.72	0.54	0.35	0.83	0.74	0.56	0.36	0.85	0.76	0.58	0.37	0.88	0.79	0.59	0.38	0.91	0.82	0.62	0.40	0.92	0.82	0.62	0.40
		Delta T	21	20	16	11	22	20	16	11	22	20	16	11	22	20	16	11	22	20	16	11	20	19	15	10
		KW	3.14	3.20	3.29	3.38	3.35	3.42	3.52	3.62	3.54	3.61	3.72	3.83	3.71	3.79	3.90	4.02	3.85	3.93	4.05	4.18	3.98	4.06	4.18	4.32
		AMPS	13.6	13.9	14.2	14.7	14.5	14.8	15.2	15.6	15.5	15.8	16.2	16.7	16.4	16.7	17.2	17.7	17.2	17.6	18.1	18.7	18.1	18.5	19.0	19.6
		HI PR	227	244	258	269	254	274	289	302	289	311	329	343	330	355	375	391	371	399	421	439	410	441	466	486
LO PR	108	115	126	134	114	122	133	141	119	126	138	147	125	133	145	154	131	139	152	162	136	144	157	167		

* IDB: Entering Indoor Dry Bulb Temperature

High and low pressures are measured at the liquid and suction access fittings.

NOTE: Shaded area is ACCA (TVA) conditions

COOLING PERFORMANCE DATA

5MM COILS

GPC1349H41AA

EXPANDED PERFORMANCE DATA

MODEL: GPC1349H41A*

COOLING OPERATION

IDB*	Airflow	Outdoor Ambient Temperature																									
		65				75				85				95				105				115					
		59	63	67	71	59	63	67	71	59	63	67	71	59	63	67	71	59	63	67	71	59	63	67	71		
80	1800	MBh	46.1	47.2	50.4	53.9	45.1	46.1	49.2	52.6	44.0	45.0	48.0	51.4	42.9	43.9	46.9	50.1	40.8	41.7	44.5	47.6	37.8	38.6	41.2	44.1	
		ST	0.96	0.90	0.73	0.55	1.00	0.93	0.76	0.56	1.00	0.95	0.78	0.58	1.00	1.00	0.80	0.60	0.60	1.00	1.00	0.83	0.62	1.00	1.00	0.84	0.63
		Delta T	2.3	2.2	1.9	1.5	2.3	2.2	1.9	1.5	2.2	2.2	2.2	1.5	2.2	2.2	2.2	1.5	2.1	2.1	2.1	1.9	1.5	2.1	2.0	1.8	1.4
		KW	3.25	3.31	3.41	3.51	3.48	3.55	3.65	3.76	3.68	3.75	3.87	3.98	3.86	3.94	4.06	4.18	4.01	4.09	4.22	4.35	4.14	4.22	4.35	4.49	4.49
		AMPS	14.1	14.4	14.8	15.2	15.0	15.3	15.7	16.2	16.1	16.4	16.9	17.4	17.0	17.4	17.9	18.4	17.9	18.3	18.8	19.4	18.8	19.2	19.8	20.4	20.4
	1600	HI PR	238	257	271	283	268	288	304	317	304	328	346	361	347	373	394	411	390	420	443	462	431	464	490	511	
		LO PR	114	121	132	141	120	128	140	149	125	133	145	155	131	140	153	162	138	146	160	170	142	151	165	176	
		MBh	44.8	45.8	48.9	52.3	43.8	44.7	47.8	51.1	42.7	43.7	46.6	49.9	41.7	42.6	45.5	48.6	39.6	40.5	43.2	46.2	36.7	37.5	40.0	42.8	
		ST	0.91	0.85	0.70	0.52	0.94	0.89	0.72	0.54	0.97	0.91	0.74	0.55	1.00	0.94	0.76	0.57	1.00	0.97	0.79	0.59	1.00	0.98	0.80	0.60	
		Delta T	2.3	2.2	2.0	1.6	2.4	2.3	2.0	1.6	2.4	2.3	2.0	1.6	2.4	2.3	2.0	1.6	2.4	2.3	2.0	1.6	2.1	2.1	1.8	1.5	
1400	KW	3.23	3.29	3.38	3.48	3.45	3.52	3.62	3.73	3.65	3.73	3.84	3.95	3.83	3.91	4.02	4.15	3.98	4.06	4.18	4.31	4.11	4.19	4.32	4.46		
	AMPS	14.0	14.3	14.7	15.1	14.9	15.2	15.6	16.1	16.0	16.3	16.7	17.3	16.9	17.2	17.7	18.3	17.8	18.2	18.7	19.3	18.7	19.1	19.6	20.3		
	HI PR	236	254	268	280	265	285	301	314	301	324	342	357	343	369	390	407	386	415	439	458	427	459	485	506		
	LO PR	113	120	131	139	119	127	138	147	124	132	144	153	130	138	151	161	136	145	158	169	141	150	164	174		
	MBh	41.4	42.3	45.1	48.3	40.4	41.3	44.1	47.1	39.4	40.3	43.0	46.0	38.5	39.3	42.0	44.9	36.5	37.3	39.9	42.6	33.9	34.6	37.0	39.5		
85	1800	ST	0.88	0.82	0.67	0.50	0.91	0.85	0.70	0.52	0.93	0.88	0.71	0.53	0.96	0.90	0.74	0.55	1.00	0.94	0.76	0.57	1.01	0.95	0.77	0.58	
		Delta T	2.4	2.3	2.0	1.6	2.4	2.3	2.0	1.6	2.4	2.3	2.0	1.6	2.4	2.3	2.0	1.6	2.4	2.3	2.0	1.6	2.2	2.1	1.9	1.5	
		KW	3.16	3.22	3.31	3.41	3.38	3.44	3.54	3.65	3.57	3.64	3.75	3.86	3.74	3.82	3.93	4.05	3.88	3.96	4.08	4.21	4.01	4.09	4.22	4.35	
		AMPS	13.7	14.0	14.3	14.8	14.6	14.9	15.3	15.7	15.6	15.9	16.4	16.9	16.5	16.8	17.3	17.9	17.4	17.7	18.2	18.8	18.2	18.6	19.2	19.8	
		HI PR	229	246	260	271	257	277	292	305	292	315	332	346	333	358	378	395	375	403	426	444	414	445	470	490	
	1600	LO PR	109	116	127	135	116	123	134	143	120	128	139	149	126	134	146	156	132	141	154	163	137	145	159	169	
		MBh	47.0	47.9	50.1	53.5	45.9	46.7	49.0	52.2	44.8	45.6	47.8	51.0	43.7	44.5	46.6	49.7	41.5	42.3	44.3	47.3	38.4	39.2	41.0	43.8	
		ST	1.00	0.97	0.87	0.71	1.00	1.00	0.90	0.73	1.00	1.00	0.93	0.75	1.00	1.00	0.96	0.78	1.00	1.00	0.99	0.81	1.00	1.00	1.00	0.81	
		Delta T	2.4	2.4	2.2	1.9	2.3	2.4	2.3	2.0	2.3	2.3	2.3	2.0	2.2	2.3	2.3	2.0	2.1	2.2	2.2	1.9	2.0	2.0	2.1	1.8	
		KW	3.28	3.34	3.43	3.54	3.50	3.57	3.68	3.79	3.71	3.78	3.90	4.02	3.89	3.97	4.09	4.21	4.04	4.12	4.25	4.38	4.17	4.26	4.39	4.53	
1400	AMPS	14.2	14.5	14.9	15.3	15.1	15.4	15.9	16.4	16.2	16.5	17.0	17.5	17.1	17.5	18.0	18.6	18.1	18.5	19.0	19.6	19.0	19.4	20.0	20.6		
	HI PR	241	259	274	285	270	291	307	320	307	331	349	364	350	377	398	415	394	424	448	467	435	468	495	516		
	LO PR	115	122	134	142	121	129	141	150	126	134	147	156	133	141	154	164	139	148	161	172	144	153	167	178		
	MBh	45.6	46.5	48.7	51.9	44.5	45.4	47.5	50.7	43.5	44.3	46.4	49.5	42.4	43.2	45.3	48.3	40.3	41.1	43.0	45.9	37.3	38.0	39.8	42.5		
	ST	0.96	0.92	0.83	0.67	0.99	0.96	0.86	0.70	1.00	0.98	0.88	0.72	1.00	1.00	0.91	0.74	1.00	1.00	0.95	0.77	1.00	1.00	0.96	0.77		
85	1600	Delta T	2.5	2.5	2.3	2.0	2.5	2.5	2.4	2.0	2.5	2.5	2.4	2.0	2.4	2.5	2.4	2.1	2.3	2.4	2.3	2.0	2.1	2.2	2.2	1.9	
		KW	3.25	3.31	3.41	3.51	3.48	3.55	3.65	3.76	3.68	3.75	3.87	3.98	3.86	3.94	4.06	4.18	4.01	4.09	4.22	4.35	4.14	4.22	4.35	4.49	
		AMPS	14.1	14.4	14.8	15.2	15.0	15.3	15.7	16.2	16.1	16.4	16.9	17.4	17.0	17.4	17.9	18.4	17.9	18.3	18.8	19.4	18.8	19.2	19.8	20.4	
		HI PR	238	257	271	283	268	288	304	317	304	328	346	361	347	373	394	411	390	420	443	462	431	464	490	511	
		LO PR	114	121	132	141	120	128	140	149	125	133	145	155	131	140	153	162	138	146	160	170	142	151	165	176	
	1400	MBh	42.1	42.9	44.9	47.9	41.1	41.9	43.9	46.8	40.1	40.9	42.8	45.7	39.1	39.9	41.8	44.6	37.2	37.9	39.7	42.4	34.4	35.1	36.8	39.2	
		ST	0.92	0.89	0.80	0.65	0.95	0.92	0.83	0.67	0.98	0.94	0.85	0.69	1.00	0.97	0.88	0.71	1.00	1.00	0.91	0.74	1.00	1.00	0.92	0.75	
		Delta T	2.5	2.5	2.4	2.0	2.6	2.5	2.4	2.1	2.6	2.5	2.4	2.1	2.6	2.6	2.4	2.1	2.4	2.5	2.4	2.1	2.3	2.3	2.2	1.9	
		KW	3.18	3.24	3.33	3.43	3.40	3.47	3.57	3.68	3.60	3.67	3.78	3.89	3.77	3.84	3.96	4.08	3.91	3.99	4.12	4.24	4.04	4.12	4.25	4.38	
		AMPS	13.8	14.1	14.4	14.9	14.7	15.0	15.4	15.9	15.7	16.0	16.5	17.0	16.6	17.0	17.4	18.0	17.5	17.9	18.4	19.0	18.4	18.8	19.3	20.0	
1400	HI PR	231	249	263	274	260	279	295	308	295	318	335	350	336	362	382	399	378	407	430	448	418	450	475	495		
	LO PR	110	117	128	137	117	124	136	144	121	129	141	150	127	136	148	158	133	142	155	165	138	147	160	171		

* NOTE: Shaded areas is A-HRI Rating Conditions
 High and low pressures are measured at the liquid and suction access fittings.
 IDB: Entering Indoor Dry Bulb Temperature
 K/W = Total system power
 AMPS: Unit amps (comp.+ evaporator + condenser fan motors)

MODEL: GPC1360H41B*

EXPANDED PERFORMANCE DATA

COOLING OPERATION

IDB*	Airflow	Outdoor Ambient Temperature																								
		75					85					95					105					115				
		59	63	67	71	75	59	63	67	71	75	59	63	67	71	75	59	63	67	71	75	59	63	67	71	75
70	1948	MBh	56.3	58.4	64.0	-	55.0	57.0	62.5	-	53.7	55.7	61.0	-	52.4	54.3	59.5	-	49.8	51.6	56.5	-	46.1	47.8	52.4	-
		ST	0.71	0.59	0.41	-	0.74	0.62	0.43	-	0.76	0.63	0.44	-	0.78	0.65	0.45	-	0.81	0.68	0.47	-	0.82	0.68	0.47	-
		Delta T	19	16	12	-	19	17	13	-	19	17	13	-	19	17	13	-	19	16	13	-	18	15	12	-
		KW	4.17	4.26	4.39	-	4.49	4.59	4.73	-	4.77	4.88	5.03	-	5.02	5.13	5.30	-	5.23	5.35	5.53	-	5.41	5.54	5.72	-
		AMPS	17.6	17.9	18.4	-	18.8	19.2	19.8	-	20.2	20.7	21.3	-	21.5	22.0	22.6	-	22.7	23.2	23.9	-	24.0	24.5	25.2	-
	1728	HI PR	249	268	283	-	279	300	317	-	317	341	361	-	361	389	411	-	407	438	462	-	449	483	510	-
		LO PR	109	116	127	-	116	123	134	-	120	128	140	-	126	134	147	-	132	141	154	-	137	146	159	-
		MBh	54.7	56.7	62.1	-	53.4	55.4	60.7	-	52.2	54.1	59.2	-	50.9	52.7	57.8	-	48.3	50.1	54.9	-	44.8	46.4	50.9	-
		ST	0.68	0.57	0.39	-	0.70	0.59	0.41	-	0.72	0.60	0.42	-	0.75	0.62	0.43	-	0.77	0.65	0.45	-	0.78	0.65	0.45	-
		Delta T	20	17	13	-	20	17	13	-	20	17	13	-	20	17	13	-	20	17	13	-	19	16	12	-
1518	KW	4.14	4.22	4.36	-	4.45	4.55	4.69	-	4.73	4.84	4.99	-	4.98	5.09	5.26	-	5.19	5.30	5.48	-	5.37	5.49	5.67	-	
	AMPS	17.4	17.8	18.3	-	18.7	19.0	19.6	-	20.1	20.5	21.1	-	21.3	21.8	22.4	-	22.5	23.0	23.7	-	23.8	24.3	25.0	-	
	HI PR	246	265	280	-	276	297	314	-	314	338	357	-	358	385	407	-	403	433	457	-	445	479	505	-	
	LO PR	108	115	126	-	114	122	133	-	119	127	138	-	125	133	145	-	131	139	152	-	135	144	157	-	
	MBh	50.5	52.3	57.3	-	49.3	51.1	56.0	-	48.1	49.9	54.7	-	47.0	48.7	53.3	-	44.6	46.2	50.7	-	41.3	42.8	46.9	-	
75	1948	ST	0.65	0.55	0.38	-	0.68	0.57	0.39	-	0.70	0.58	0.40	-	0.72	0.60	0.42	-	0.75	0.62	0.43	-	0.75	0.63	0.44	-
		Delta T	20	17	13	-	20	18	13	-	20	18	13	-	20	18	13	-	20	17	13	-	19	16	12	-
		KW	4.04	4.12	4.25	-	4.35	4.44	4.58	-	4.62	4.72	4.87	-	4.86	4.96	5.12	-	5.06	5.17	5.34	-	5.23	5.35	5.53	-
		AMPS	17.0	17.4	17.9	-	18.2	18.6	19.1	-	19.6	20.0	20.6	-	20.8	21.2	21.9	-	22.0	22.5	23.1	-	23.1	23.7	24.4	-
		HI PR	239	257	271	-	268	288	304	-	305	328	346	-	347	374	394	-	390	420	444	-	431	464	490	-
	1728	LO PR	105	112	122	-	111	118	129	-	115	123	134	-	121	129	141	-	127	135	148	-	131	140	153	-
		MBh	57.3	59.0	63.9	68.5	56.0	57.6	62.4	66.9	54.6	56.3	60.9	65.3	53.3	54.9	59.4	63.8	50.6	52.1	56.4	60.6	46.9	48.3	52.3	56.1
		ST	0.81	0.72	0.55	0.35	0.84	0.75	0.57	0.37	0.86	0.77	0.58	0.37	0.89	0.79	0.60	0.39	0.92	0.82	0.62	0.40	0.93	0.83	0.63	0.40
		Delta T	22	20	17	11	22	20	17	12	22	20	17	12	22	21	17	12	22	20	17	11	21	19	16	11
		KW	4.20	4.29	4.43	4.57	4.53	4.62	4.77	4.93	4.81	4.92	5.08	5.24	5.06	5.17	5.34	5.52	5.28	5.39	5.57	5.76	5.46	5.58	5.77	5.97
1518	AMPS	17.7	18.1	18.6	19.2	19.0	19.4	19.9	20.6	20.4	20.9	21.5	22.2	21.7	22.1	22.8	23.6	22.9	23.4	24.1	25.0	24.2	24.7	25.5	26.4	
	HI PR	251	270	285	298	282	303	320	334	321	345	364	380	365	393	415	433	411	442	467	487	454	488	516	538	
	LO PR	111	118	128	137	117	124	136	144	121	129	141	150	128	136	148	158	134	142	155	165	138	147	161	171	
	MBh	55.6	57.3	62.0	66.5	54.3	55.9	60.6	65.0	53.0	54.6	59.1	63.4	51.8	53.3	57.7	61.9	49.2	50.6	54.8	58.8	45.5	46.9	50.8	54.5	
	ST	0.77	0.69	0.52	0.34	0.80	0.72	0.54	0.35	0.82	0.73	0.56	0.36	0.85	0.76	0.57	0.37	0.88	0.79	0.60	0.38	0.89	0.79	0.60	0.39	
1518	Delta T	23	21	17	12	23	21	17	12	23	21	17	12	23	21	18	12	23	21	17	12	21	20	16	11	
	KW	4.17	4.26	4.39	4.53	4.49	4.59	4.73	4.89	4.77	4.88	5.03	5.20	5.02	5.13	5.30	5.48	5.23	5.35	5.53	5.71	5.42	5.54	5.72	5.92	
	AMPS	17.6	17.9	18.4	19.0	18.8	19.2	19.8	20.4	20.2	20.7	21.3	22.0	21.5	22.0	22.6	23.4	22.7	23.2	23.9	24.8	24.0	24.5	25.2	26.1	
	HI PR	249	268	283	295	279	300	317	331	317	342	361	376	361	389	411	428	407	438	462	482	449	484	511	533	
	LO PR	109	116	127	135	116	123	134	143	120	128	140	149	126	134	147	156	132	141	154	164	137	146	159	169	
1518	MBh	51.3	52.9	57.2	61.4	50.2	51.6	55.9	60.0	49.0	50.4	54.6	58.6	47.8	49.2	53.2	57.1	45.4	46.7	50.6	54.3	42.0	43.3	46.8	50.3	
	ST	0.74	0.67	0.50	0.32	0.77	0.69	0.52	0.34	0.79	0.71	0.54	0.34	0.82	0.73	0.55	0.36	0.85	0.76	0.57	0.37	0.85	0.76	0.58	0.37	
	Delta T	23	21	17	12	23	22	18	12	23	22	18	12	24	22	18	12	23	21	18	12	22	20	16	11	
	KW	4.07	4.16	4.29	4.42	4.38	4.47	4.62	4.77	4.66	4.76	4.91	5.07	4.90	5.00	5.17	5.34	5.10	5.21	5.39	5.57	5.28	5.40	5.58	5.76	
	AMPS	17.1	17.5	18.0	18.6	18.4	18.7	19.3	19.9	19.7	20.2	20.8	21.5	21.0	21.4	22.1	22.8	22.2	22.6	23.3	24.1	23.3	23.9	24.6	25.5	
1518	HI PR	241	260	274	286	271	291	308	321	308	331	350	365	351	377	398	416	394	424	448	468	436	469	495	517	
	LO PR	106	113	123	131	112	119	130	139	117	124	135	144	122	130	142	151	128	137	149	159	133	141	154	164	

* IDB: Entering Indoor Dry Bulb Temperature

High and low pressures are measured at the liquid and suction access fittings.

NOTE: Shaded area is ACCA (TVA) conditions

IDB*	Airflow	Outdoor Ambient Temperature																													
		65					75					85					95					105					115				
		59	63	67	71	75	59	63	67	71	75	59	63	67	71	75	59	63	67	71	75	59	63	67	71	75	59	63	67	71	75
80	1948	MBh	58.3	59.6	63.7	68.1	57.0	58.2	62.2	66.5	55.6	56.8	60.7	64.9	54.3	55.4	59.2	63.3	51.5	52.7	56.3	60.1	47.7	48.8	52.1	55.7					
		ST	0.89	0.83	0.68	0.51	0.92	0.86	0.70	0.52	0.94	0.88	0.72	0.54	1.00	0.91	0.74	0.56	1.00	0.96	0.77	0.58	1.00	0.96	0.78	0.58					
		Delta T	24	23	20	16	25	24	21	16	25	24	21	16	26	24	21	17	24	24	20	16	23	22	19	15					
		KW	4.24	4.33	4.46	4.61	4.56	4.66	4.81	4.97	4.85	4.96	5.12	5.29	5.11	5.22	5.39	5.57	5.32	5.44	5.62	5.81	5.51	5.63	5.82	6.02					
		AMPS	17.8	18.2	18.7	19.4	19.1	19.5	20.1	20.8	20.6	21.0	21.7	22.4	21.8	22.3	23.0	23.8	23.1	23.6	24.4	25.2	24.4	24.9	25.7	26.6					
	1728	HI PR	254	273	288	301	285	306	324	337	324	348	368	384	369	397	419	437	415	446	471	492	458	493	521	543					
		LO PR	112	119	130	138	118	126	137	146	123	130	142	152	129	137	150	159	135	144	157	167	140	149	162	173					
		MBh	56.6	57.9	61.8	66.1	55.3	56.5	60.4	64.5	54.0	55.2	58.9	63.0	52.7	53.8	57.5	61.5	50.0	51.1	54.6	58.4	46.3	47.4	50.6	54.1					
		ST	0.85	0.79	0.65	0.48	0.88	0.82	0.67	0.50	0.90	0.84	0.69	0.51	0.93	0.87	0.71	0.53	0.96	0.90	0.74	0.55	0.97	0.91	0.74	0.55					
		Delta T	26	24	21	17	26	25	22	17	26	25	22	17	26	25	22	17	26	25	21	17	24	23	20	16					
1518	KW	4.20	4.29	4.43	4.57	4.53	4.62	4.77	4.93	4.81	4.92	5.08	5.24	5.06	5.17	5.35	5.52	5.28	5.39	5.57	5.76	5.46	5.58	5.77	5.97						
	AMPS	17.7	18.1	18.6	19.2	19.0	19.4	19.9	20.6	20.4	20.9	21.5	22.2	21.7	22.1	22.8	23.6	22.9	23.4	24.1	25.0	24.2	24.7	25.5	26.4						
	HI PR	251	270	285	298	282	303	320	334	321	345	364	380	365	393	415	433	411	442	467	487	454	488	516	538						
	LO PR	111	118	128	137	117	124	136	144	121	129	141	150	128	136	148	158	134	142	155	165	138	147	161	171						
	MBh	52.3	53.4	57.1	61.0	51.0	52.2	55.7	59.6	49.8	50.9	54.4	58.2	48.6	49.7	53.1	56.7	46.2	47.2	50.4	53.9	42.8	43.7	46.7	49.9						
85	1948	ST	0.82	0.77	0.62	0.47	0.85	0.79	0.65	0.48	0.87	0.81	0.66	0.50	0.90	0.84	0.68	0.51	0.93	0.87	0.71	0.53	0.94	0.88	0.72	0.53					
		Delta T	26	25	22	17	26	25	22	17	26	25	22	17	26	25	22	18	26	25	22	17	24	23	20	16					
		KW	4.10	4.19	4.32	4.46	4.42	4.51	4.66	4.81	4.69	4.80	4.95	5.11	4.94	5.05	5.21	5.38	5.14	5.26	5.43	5.61	5.32	5.44	5.62	5.81					
		AMPS	17.3	17.6	18.1	18.7	18.5	18.9	19.4	20.1	19.9	20.3	20.9	21.6	21.1	21.6	22.2	23.0	22.3	22.8	23.5	24.3	23.5	24.1	24.8	25.7					
		HI PR	244	262	277	289	273	294	311	324	311	335	353	369	354	381	402	420	398	429	453	472	440	474	500	522					
	1728	LO PR	107	114	125	133	113	121	132	140	118	125	137	146	124	132	144	153	130	138	151	160	134	143	156	166					
		MBh	59.3	60.5	63.3	67.6	58.0	59.1	61.9	66.0	56.6	57.7	60.4	64.4	55.2	56.3	58.9	62.9	52.4	53.5	56.0	59.7	48.6	49.5	51.9	55.3					
		ST	0.93	0.90	0.81	0.66	0.96	0.93	0.84	0.68	0.99	0.95	0.86	0.70	1.00	0.99	0.89	0.72	1.00	1.00	0.92	0.75	1.00	1.00	0.93	0.75					
		Delta T	26	26	24	21	26	26	25	21	26	26	25	21	26	26	25	21	25	25	24	21	23	23	23	20					
		KW	4.27	4.36	4.50	4.64	4.60	4.70	4.85	5.01	4.89	5.00	5.16	5.33	5.15	5.26	5.43	5.62	5.37	5.49	5.67	5.86	5.55	5.68	5.87	6.07					
1518	AMPS	18.0	18.4	18.9	19.5	19.3	19.7	20.3	20.9	20.7	21.2	21.8	22.6	22.0	22.5	23.2	24.0	23.3	23.8	24.6	25.4	24.6	25.1	25.9	26.8						
	HI PR	256	276	291	304	288	309	327	341	327	352	372	388	372	401	423	441	419	451	476	497	463	498	526	549						
	LO PR	113	120	131	139	119	127	138	147	124	132	144	153	130	138	151	161	136	145	158	169	141	150	164	174						
	MBh	57.6	58.7	61.5	65.6	56.3	57.4	60.1	64.1	54.9	56.0	58.6	62.6	53.6	54.6	57.2	61.0	50.9	51.9	54.4	58.0	47.2	48.1	50.3	53.7						
	ST	0.89	0.86	0.77	0.63	0.92	0.89	0.80	0.65	0.94	0.91	0.82	0.67	0.97	0.94	0.85	0.69	1.00	0.98	0.88	0.71	1.00	0.98	0.89	0.72						
85	1728	Delta T	27	27	25	22	28	27	26	22	28	27	26	22	28	27	26	22	27	27	25	22	25	25	24	21					
		KW	4.24	4.33	4.46	4.61	4.56	4.66	4.81	4.97	4.85	4.96	5.12	5.29	5.11	5.22	5.39	5.57	5.32	5.44	5.62	5.81	5.51	5.63	5.82	6.02					
		AMPS	17.8	18.2	18.7	19.4	19.1	19.5	20.1	20.8	20.6	21.0	21.7	22.4	21.8	22.3	23.0	23.8	23.1	23.6	24.4	25.2	24.4	24.9	25.7	26.6					
		HI PR	254	273	288	301	285	306	324	337	324	348	368	384	369	397	419	437	415	446	471	492	458	493	521	543					
		LO PR	112	119	130	138	118	126	137	146	123	130	142	152	129	137	150	159	135	144	157	167	140	149	162	173					
	1518	MBh	53.2	54.2	56.8	60.6	51.9	52.9	55.4	59.2	50.7	51.7	54.1	57.7	49.5	50.4	52.8	56.3	47.0	47.9	50.2	53.5	43.5	44.4	46.5	49.6					
		ST	0.86	0.83	0.75	0.60	0.89	0.86	0.77	0.63	0.91	0.88	0.79	0.64	0.94	0.91	0.82	0.66	0.97	0.94	0.85	0.69	0.98	0.95	0.86	0.69					
		Delta T	28	27	26	22	28	27	26	22	28	27	26	22	28	28	26	23	28	27	26	22	26	25	24	21					
		KW	4.14	4.22	4.36	4.49	4.45	4.55	4.69	4.85	4.73	4.83	4.99	5.16	4.98	5.09	5.25	5.43	5.19	5.30	5.48	5.66	5.37	5.49	5.67	5.86					
		AMPS	17.4	17.8	18.3	18.9	18.6	19.0	19.6	20.2	20.1	20.5	21.1	21.8	21.3	21.8	22.4	23.2	22.5	23.0	23.7	24.6	23.7	24.3	25.0	25.9					
1518	HI PR	246	265	280	292	276	297	314	327	314	338	357	372	358	385	406	424	402	433	457	477	445	478	505	527						
	LO PR	108	115	126	134	114	122	133	142	119	127	138	147	125	133	145	155	131	139	152	162	135	144	157	168						

NOTE: Shaded areas reflect ARI rating conditions

IDB*	Airflow	Outdoor Ambient Temperature																													
		65					75					85					95					105					115				
		59	63	67	71	75	59	63	67	71	75	59	63	67	71	75	59	63	67	71	75	59	63	67	71	75	59	63	67	71	75
85	1948	MBh	59.3	60.5	63.3	67.6	58.0	59.1	61.9	66.0	56.6	57.7	60.4	64.4	55.2	56.3	58.9	62.9	52.4	53.5	56.0	59.7	48.6	49.5	51.9	55.3					
		ST	0.93	0.90	0.81	0.66	0.96	0.93	0.84	0.68	0.99	0.95	0.86	0.70	1.00	0.99	0.89	0.72	1.00	1.00	0.92	0.75	1.00	1.00	0.93	0.75					
		Delta T	26	26	24	21	26	26	25	21	26	26	25	21	26	26	25	21	25	25	24	21	23	23	23	20					
		KW	4.27	4.36	4.50	4.64	4.60	4.70	4.85	5.01	4.89	5.00	5.16	5.33	5.15	5.26	5.43	5.62	5.37	5.49	5.67	5.86	5.55	5.68	5.87	6.07					
		AMPS	18.0	18.4	18.9	19.5	19.3	19.7	20.3	20.9	20.7	21.2	21.8	22.6	22.0	22.5	23.2	24.0	23.3	23.8	24.6	25.4	24.6	25.1	25.9	26.8					
	1728	HI PR	256	276	291	304	288	309	327	341	327	352	372	388	372	401	423	441	419	451	476	497	463	498	526	549					
		LO PR	113	120	131	139	119	127	138	147	124	132	144	153	130	138	151	161	136	145	158	169	141	150	164	174					
		MBh	57.6	58.7	61.5	65.6	56.3	57.4	60.1	64.1	54.9	56.0	58.6	62.6	53.6	54.6	57.2	61.0	50.9	51.9	54.4	58.0	47.2	48.1	50.3	53.7					
		ST	0.89	0.86	0.77	0.63	0.92	0.89	0.80	0.65	0.94	0.91	0.82	0.67	0.97	0.94	0.85	0.69	1.00	0.98	0.88	0.71	1.00	0.98							

COOLING PERFORMANCE DATA

PERFORMANCE TEST

All data based upon listed indoor dry bulb temperature. .00 inches external static pressure on coil of outdoor section. Indoor air cubic feet per minute (CFM) as listed in the Performance Data Sheets:

If conditions vary from this, results will change as follows:

1. As indoor dry bulb temperatures increase, a slight increase will occur in indoor air temperature drop (Delta T). Low and high side pressures and power will not change.
2. As indoor CFM decreases, a slight increase will occur in indoor temperature drop (Delta T). A slight decrease will occur in low and high side pressures and power.

A properly operating unit should be within plus or minus **3 degrees** of the typical (**Delta T**) value shown.

A properly operating unit should be within plus or minus **7 PSIG** of the **HI PR** shown.

A properly operating unit should be within plus or minus **3 PSIG** of the **LO PR** shown.

A properly operating unit should be within plus or minus **3 Amps** of the typical value shown.



HIGH VOLTAGE!
DISCONNECT ALL POWER BEFORE SERVICING OR INSTALLING THIS UNIT. MULTIPLE POWER SOURCES MAY BE PRESENT. FAILURE TO DO SO MAY CAUSE PROPERTY DAMAGE, PERSONAL INJURY OR DEATH.

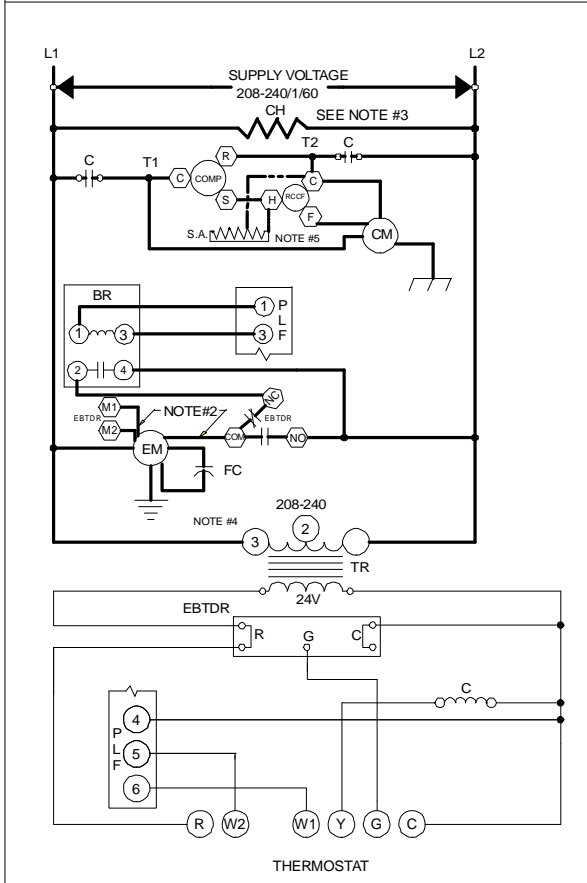
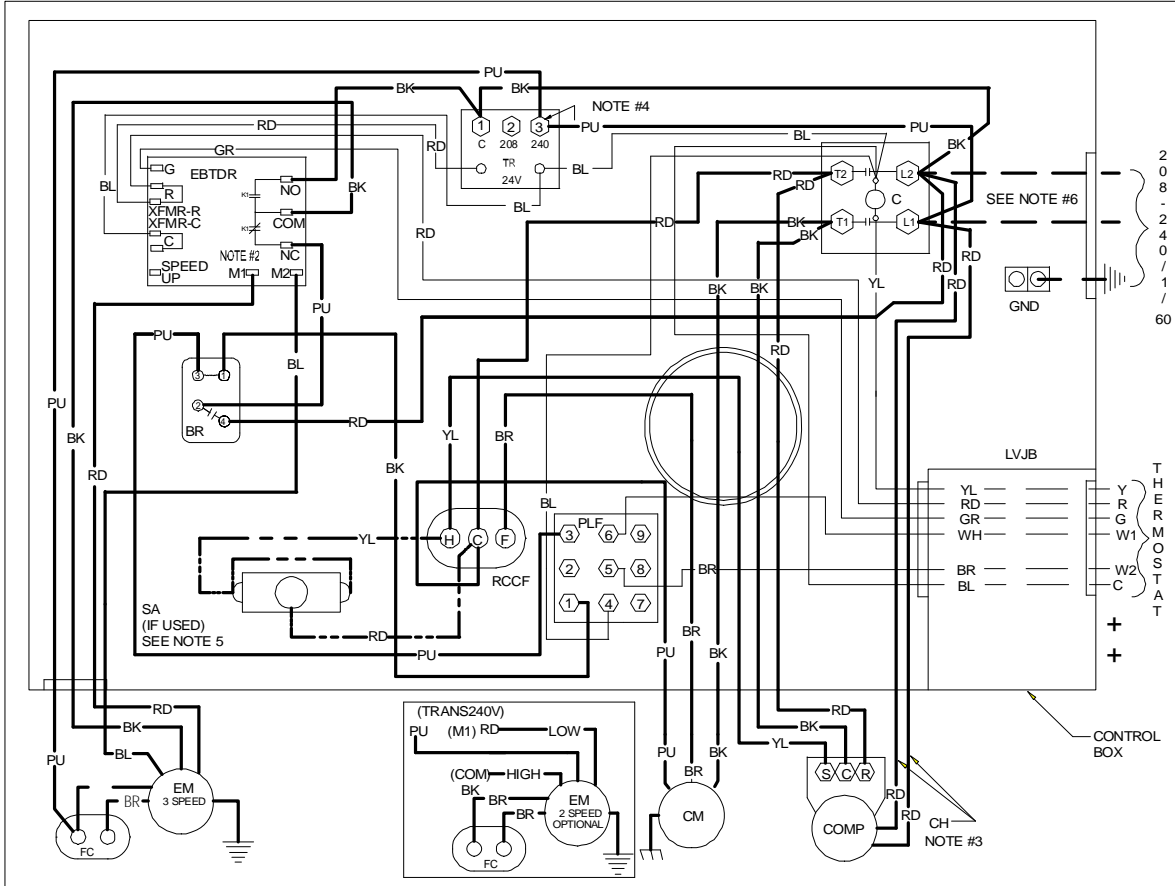

COMPONENT LEGEND

BR	BLOWER INTERLOCK RELAY	---	LINE VOLTAGE
C	CONTACTOR	---	LOW VOLTAGE
CH	CRANKCASE HEATER	---	OPTIONAL HIGH VOLTAGE
CM	CONDENSER MOTOR	---	VOLTAGE
COMP	COMPRESSOR	---	FIELD WIRING
EBTD	ELECTRONIC BLOWER TIME DELAY RELAY	---	HIGH VOLTAGE
R	RELAY	---	LOW VOLTAGE
EM	EVAPORATOR MOTOR		
FC	FAN CAPACITOR		
GND	EQUIPMENT GROUND		
LVJB	LOW VOLTAGE JUNCTION BOX		
PLF	FEMALE PLUG / CONNECTOR		
RCCF	RUN CAPACITOR FOR COMPRESSOR AND FAN		
SA	START ASSIST		
TR	TRANSFORMER		

WIRE CODE

BK	BLACK
BL	BLUE
BR	BROWN
GR	GREEN
OR	ORANGE
PU	PURPLE
RD	RED
WH	WHITE
YL	YELLOW

NOTES:

1. REPLACEMENT WIRE MUST BE SAME SIZE AND TYPE INSULATION AS ORIGINAL (AT LEAST 105°C) USE COPPER CONDUCTOR ONLY.
2. TO CHANGE EVAPORATOR MOTOR SPEED REPLACE LEAD ON EBTDR "COM" WITH LEAD ON EBTDR "M1" OR "M2"
3. CRANKCASE HEAT NOT SUPPLIED ON ALL UNITS.
4. FOR 208 VOLT TRANSFORMER OPERATION MOVE PURPLE WIRES FROM TERMINAL 3 TO TERMINAL 2 ON TRANSFORMER.
5. START ASSIST FACTOR EQUIPPED WHEN REQUIRED
6. USE COPPER CONDUCTORS ONLY

++ USE N.E.C. CLASS 2 WIRE

SEE UNIT RATING PLATE FOR TYPE AND SIZE OF OVER CURRENT PROTECTION

208-240/1/60 0140G00364 REV. A

Wiring is subject to change. Always refer to the wiring diagram on the unit for the most up-to-date wiring.



HIGH VOLTAGE!
 DISCONNECT ALL POWER BEFORE SERVICING OR INSTALLING THIS UNIT. MULTIPLE POWER SOURCES MAY BE PRESENT. FAILURE TO DO SO MAY CAUSE PROPERTY DAMAGE, PERSONAL INJURY OR DEATH.

WARNING

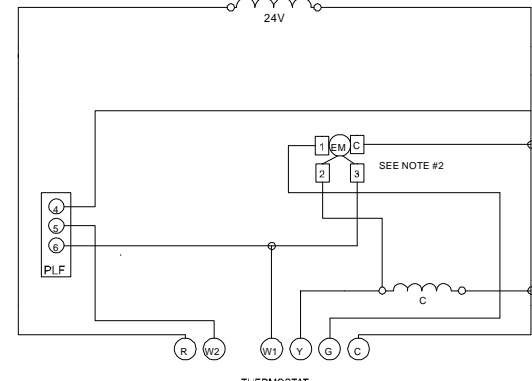
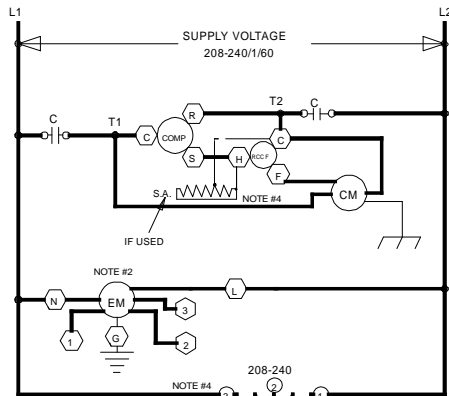
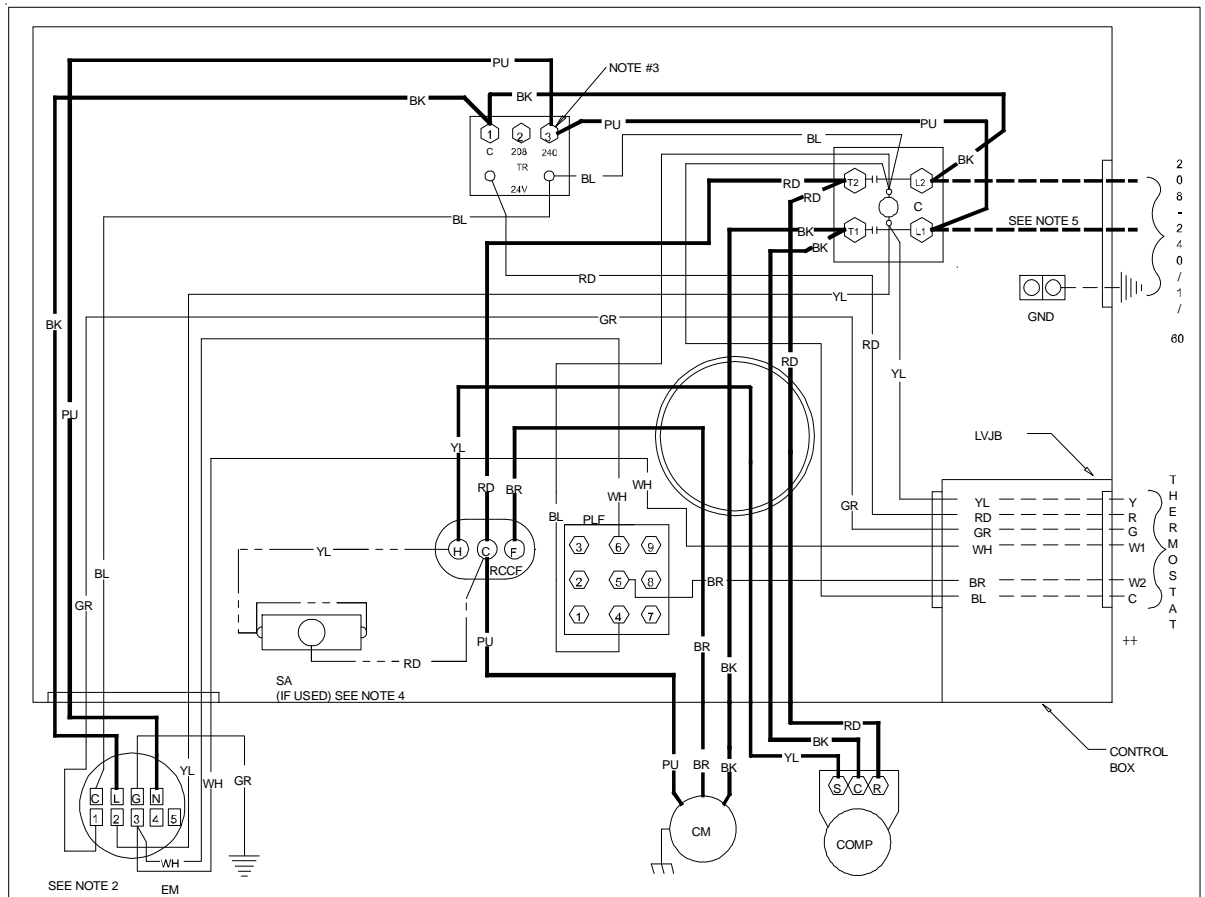

COMPONENT LEGEND

- C CONTACTOR
- CM CONDENSER MOTOR
- COMP COMPRESSOR
- EM EVAPORATOR MOTOR
- GND EQUIPMENT GROUND
- LVJB LOW VOLTAGE JUNCTION BOX
- PLF FEMALE PLUG / CONNECTOR
- RCCF RUN CAPACITOR FOR COMPRESSOR AND FAN
- SA START ASSIST
- TR TRANSFORMER

- FACTORY WIRING
- LINE VOLTAGE
- LOW VOLTAGE
- OPTIONAL HIGH VOLTAGE

- FIELD WIRING
- HIGH VOLTAGE
- LOW VOLTAGE

- WIRE CODE**
- BK BLACK
 - BL BLUE
 - BR BROWN
 - GR GREEN
 - OR ORANGE
 - PU PURPLE
 - RD RED
 - WH WHITE
 - YL YELLOW

NOTES:

1. REPLACEMENT WIRE MUST BE SAME SIZE AND TYPE INSULATION AS ORIGINAL (AT LEAST 105°C) USE COPPER CONDUCTOR ONLY.
2. TO CHANGE EVAPORATOR MOTOR SPEED MOVE WHITE AND YELLOW LEADS FROM EM "2" AND "3" TO "4" AND "5". IF BOTH LEADS ARE ENERGIZED, THE HIGHER SPEED SETTING IS USED.
3. FOR 208 VOLT TRANSFORMER OPERATION MOVE PURPLE WIRES FROM TERMINAL 3 TO TERMINAL 2 ON TRANSFORMER.
4. START ASSIST FACTORY EQUIPPED WHEN REQUIRED
5. USE COPPER CONDUCTORS ONLY.
- ++ USE N.E.C. CLASS 2 WIRE

SEE UNIT RATING PLATE FOR TYPE AND SIZE OF OVER CURRENT PROTECTION

208-240/1/60 0140G00407

Wiring is subject to change. Always refer to the wiring diagram on the unit for the most up-to-date wiring.

Free Manuals Download Website

<http://myh66.com>

<http://usermanuals.us>

<http://www.somanuals.com>

<http://www.4manuals.cc>

<http://www.manual-lib.com>

<http://www.404manual.com>

<http://www.luxmanual.com>

<http://aubethermostatmanual.com>

Golf course search by state

<http://golfingnear.com>

Email search by domain

<http://emailbydomain.com>

Auto manuals search

<http://auto.somanuals.com>

TV manuals search

<http://tv.somanuals.com>