

electra

FRIDGE/FREEZER

MODEL Nos.

EBD 8/6

EBD 9/6

WARNINGS



IMPORTANT - PLEASE READ THIS INSTRUCTION BOOK BEFORE USING THE APPLIANCE

It is most important that this instruction book should be retained with the appliance for future reference. Should the appliance be sold or transferred to another owner, or should you move house and leave the appliance, always ensure that the instruction book is supplied with the appliance in order that the new owner can get to know the functioning of the appliance and the relevant warnings.

These warnings are provided in the interest of safety. You MUST read them carefully before installing or using the appliance.

- This product is designed to be operated by adults. Children should not be allowed to tamper with the controls or play with the product.
- Any electrical work required to install this appliance should be carried out by a qualified electrician or competent person.
- This product should be serviced by an authorised Service Centre and only genuine spare parts should be used.
- It is dangerous to alter the specifications or modify the product in any way.
- Care must be taken to ensure that the appliance does not stand on the electrical supply cable.
- Domestic fridge/freezers are designed to be used specifically for the storage of edible foodstuffs only.
- There are working parts in this product which heat up. Always ensure that there is adequate ventilation as a failure to do this will result in possible food loss. See Installation instructions.
- Parts which heat up should not be exposed. Wherever possible, the back of the appliance should be close to a wall but leaving the required distance for ventilation as stated in the installation instructions.
- Before defrosting, cleaning or maintenance work is carried out, be sure to switch off the appliance and unplug it.
- Frozen food must NOT be refrozen once it has thawed out.
- Do not place carbonated or fizzy drinks in the freezer as it creates pressure on the container which may cause it to explode, resulting in damage to the appliance.
- The cooling plate or refrigerated freezer shelves in this appliance contain channels through which the refrigerant passes. If these are punctured this would cause substantial damage to the appliance and result in food loss. **DO NOT USE SHARP INSTRUMENTS** to scrape off frost or ice. Under **NO** circumstances should solid ice be forced off the lining or shelves. Solid ice should be allowed to thaw when defrosting the appliance. See Defrost instructions.
- The appliance should be left for 2 hours after installation before it is turned on, in order to allow the refrigerant to settle.
- This appliance is heavy. Care should be taken when moving it.
- Do not remove items from the freezer compartment if your hands are damp/wet, as this could cause skin abrasions or 'frost/freezer burns'.
- Ice lollies can cause 'frost/freezer burns' if consumed straight from the freezer.
- Manufacturer's food storage recommendations should be strictly adhered to. Refer to relevant instructions.
- Under no circumstances should you attempt to repair the appliance yourself. Repairs carried out by inexperienced persons may cause injury or serious malfunctioning. Refer to your local Service Centre and always insist on genuine spare parts.
- Occasionally during the operation the outside front edges of the appliance may feel quite warm to touch, this is normal.

CONTENTS

INSTALLATION.....	PAGE 3
DOOR REVERSAL	PAGE 3
ELECTRICAL CONNECTIONS.....	PAGE 4
HOW TO USE THE TEMPERATURE CONTROL DIAL	PAGE 5
YOUR FRIDGE COMPARTMENT	PAGE 5
DEFROSTING YOUR FRIDGE COMPARTMENT.....	PAGE 5
FRESH FOOD STORAGE GUIDE.....	PAGE 6
HELPFUL HINTS WHEN BUYING FOOD	PAGE 6
YOUR FREEZER COMPARTMENT	PAGE 7
DEFROSTING YOUR FREEZER COMPARTMENT	PAGE 7
FOOD FREEZING GUIDE	PAGE 8-10
HEALTH AND SAFETY GUIDELINES.....	PAGE 11
CLEANING AND CARE	PAGE 12
WHAT HAPPENS IF SOMETHING GOES WRONG?	PAGE 12

GENERAL FEATURES (SEE ILLUSTRATION A)

1. THERMOSTAT CONTROL **PAGES 13 & 14**
2. DEFROST DRAIN
3. DOOR SHELF
4. LEVEL ADJUSTERS
5. DEFROST FLIP SPOUT
6. INTERIOR LIGHT
7. STORAGE BASKET
8. FREEZING/STORAGE SHELF
9. SALAD DRAWER
10. ADJUSTABLE SHELF
11. COOLING PLATE

INSTALLATION

1. This appliance should be located in a dry atmosphere, out of direct sunlight and away from extreme temperature e.g. not next to a cooker or other sources of direct heat, or in a very cold room e.g. an outhouse.

2. The appliance should be gently pushed into place until the table top rear ventilation grill touches the wall, see Fig 1. When in position a 50 mm (2") clear space above the appliance should be maintained. If a clear space of 50 mm (2") above the appliance is not available clearances of 25 mm (1") should be maintained on both sides of the appliance, this is to provide sufficient air circulation. Always ensure that the ventilation is kept clear from blockage by teatowels etc., because this will cause the appliance to work incorrectly.

3. Your appliance will be heavy when loaded with food and must therefore be stood on a strong firm floor which should also be level. Adjust the level by screwing out the appropriate level adjusters using your fingers or a suitable spanner (see fig. 7).

Make sure the appliance is upright and all adjusters are in firm contact with the floor, so that the cabinet doesn't rock in any direction.

4. Before switching on, make sure that the voltage of your electricity supply is the same as that indicated on the rating plate. This is located inside the cabinet behind the salad drawer.

DOOR REVERSAL

If your appliance is already in use, disconnect it from the electricity supply, remove shelves and other loose items, including food. Store food in a cool place.

Gently lay the appliance on its back (be careful to hold the product firmly until the rear wheels fitted to this product are no longer in contact with the floor) with the top held away from the floor by at least 30 cm (12"), use a stool or something similar. Make sure to use a towel or cloth at the base to protect the sides of the appliance ensuring that it does not slip. Do not support the appliance on the rear ventilation grill, (see fig. 3 for correct positioning). Remove level adjuster (1) from base of product retaining small cup spacer which is located around the threaded portion of the adjuster. In order to remove the foot / hinge assembly (2) remove screws marked (3) See fig. 3.

Remove the bottom door lifting it slightly and carefully sliding it down off the centre hinge pin (9). Remove the centre hinge (9) by taking out the fixing screw (10) pull the hinge (9) down out of the top door. See fig. 4.

The top door can then be removed by carefully sliding it down off the upper hinge pin (6) See fig. 5.

Unscrew the upper hinge pin (6) by removing screw (7) and transfer it to the opposite side of the cabinet See fig. 5.

Using a flat bladed screwdriver remove the blanking cover (11) See fig. 5. Refit cover by clipping it back onto the opposite side.

Refit the top door by carefully sliding it onto the upper hinge pin (6).

Turn the centre hinge (9) around from its illustrated position and transfer it to the opposite side. Gently

press the centre hinge up into the door. To secure the centre hinge to the cabinet, refit screw (10). Ensure the top door is correctly aligned before fully tightening the screw. This can be achieved by sideways movement of the centre hinge.

Refit the bottom door by sliding it onto the centre hinge pin. Take the bottom hinge foot assembly (2) and transfer it over to the opposite side of the cabinet being careful to retain any spacing washer fitted onto the bottom hinge pin. Push the hinge foot assembly (2) into the door bearing using the pin of the foot for location. Three holes will then line up with the hinge foot and screws (3) should be used to secure the hinge. Refit level adjuster and spacer (1) in the opposite side of the cabinet.

The base of your product should now be in line with fig. 8.

FOOT ADJUSTMENT

Your appliance will be heavy when loaded with food and must therefore be stood on a strong firm floor. It should also be level. Adjust the level by screwing out the appropriate level adjusters at the front, using your fingers or a suitable spanner (see fig. 2). Make sure the appliance is upright and both adjusters are in firm contact with the floor so that the cabinet is level and doesn't rock in any direction.

Switch on and replace the food.

ELECTRICAL CONNECTIONS

WARNING: THIS APPLIANCE MUST BE EARTHED.

The manufacturer declines any liability should this safety measure not be observed.

ELECTRICAL REQUIREMENTS

Before switching on, make sure that the voltage of your electricity supply is the same as that indicated on the rating plate, located inside the cabinet.

WARNING! THIS APPLIANCE MUST BE EARTHED

For your convenience, this appliance comes complete with either a moulded-on or re-wireable 13 amp (BS1363) plug, protected by a 13 amp ASTA approved (BS1362) fuse.

In the event of having to change the fuse in the plug supplied, a replacement 13 amp ASTA approved (BS1362) fuse must be used.

In the case of a moulded-on plug, if a removable fuse cover is fitted, the fuse cover MUST be refitted after changing the fuse. If the fuse cover is lost or damaged the plug MUST NOT be used until a replacement is obtained.

Replacement covers are available from your local electricity shop or nearest customer service centre. The colour of the replacement fuse cover must match the colour insert or emboss on the base of the plug.

In the case of a re-wireable plug, care must be taken to ensure that the top cover is refitted without causing damage to either the top cover or base. In the event of the plug becoming damaged or cracked, it must be replaced with an equivalent 13 amp, BS1363 approved plug (ref. fig.9) and rewired using the following procedure:-

IMPORTANT

The wires in the mains lead are coloured in accordance with the following code:

GREEN & YELLOW	: EARTH
BLUE	: NEUTRAL
BROWN	: LIVE

The wire coloured green and yellow must be connected to the terminal marked with the letter "E" or by the Earth Symbol  or coloured green or green and yellow. The wire coloured Blue must be connected to the terminal marked with the letter "N" or coloured black. The wire coloured Brown must be connected to the terminal marked "L" or coloured red.

Upon completion there must be no cut, loose or stray strands of wire present and the cord clamp must be secure over the outer sheath.

If a 13 amp (BS1363) plug is unsuitable for your sockets, the plug should be removed, (cut-off in the case of a moulded-on plug) and an appropriate plug fitted.

NOTE: Moulded plugs cannot be re-used and should be discarded if cut from a mains lead, as insertion into a 13 A socket could prove fatal.

If a non-fused plug is fitted (ref. fig.10), the wiring must follow the above procedure and the appliance must be protected by the use of a 15amp fuse either in the adaptor or at the distribution board.

If at any time a replacement supply cord is required, the cross sectional area of its conductors must not be less than 0.75mm² and the cable clamp must be tightened so as to fully retain the new cord.

We recommend that this type of installation be checked by a fully qualified electrician, prior to use.

Conformity Declaration:

This appliance is designed to store food in and is manufactured in conformity with:

EEC Directive No. 89/109/EEC

This appliance has been designed and built in compliance with:

The "Low Voltage" EEC Directive 73/23/EEC.

The "EMC-EEC" Directive 89/336/EEC (amended by EEC Directive 93/68/EEC).

This appliance is CFC Free.

For more details, please refer to the rating plate on the appliances.

This appliance carries the CE Mark.

HOW TO USE THE TEMPERATURE CONTROL DIAL

There is one control for setting the temperature of both the fridge and freezer compartments, this is situated in the larder cabinet. On "B" type models, see Fig.11 and in the table top on "A" type models, see Fig12.

To start the cooling system, plug into the wall socket and switch the mains on. Turn the thermostat to the recommended setting.

Type A Models:

A coin is required to operate the table top mounted thermostat, the thermostat dial should be turned to align the black indicator in the knob with the required setting. A setting of between 4-5 will usually be found suitable for normal operations however this may need adjusting depending on the conditions.

Type B Models:

The thermostat dial should be turned to align the

required setting with the indicator arrow on the housing. A setting of between 3-4 will usually be found suitable for normal operations however this may need adjusting depending on the conditions.

The temperature in the fridge and freezer compartment will be affected by location, room temperature and frequency of door openings and adjustment of the thermostat setting may be needed to allow for this. When operating the outside front edges of the freezer may feel warm to the touch. This is quite normal.

If a lower temperature is needed (e.g during hot weather) turn the thermostat knob to a higher number, the highest number is the coldest setting.

If colder settings are selected for extra chilling effect do not forget to turn the control dial back to the correct setting afterwards.

YOUR FRIDGE COMPARTMENT

TEMPERATURES

The function of a refrigerator is to reduce the development of organisms which cause decay and bacterial activity, and thus increase the storage life of food.

The fresh food compartment has been designed to operate between 0°C (32°F) and 5°C (41°F) and is in accordance with British and European Standards.

FRESH FOOD COMPARTMENT

The refrigerator is fitted with shelves which are adjustable for the storage of different sized articles.

If your appliance is positioned near to a wall thereby allowing the door to open through 90° then each shelf when tilted can be removed as follows, see Fig 14.

The shelves are designed to allow maximum air circulation and therefore when placing foods on the shelves make sure a small space is left between packages.

The warmest area in the refrigerator is to the top of the compartment and the coolest is at the bottom of the compartment and this is where the most perishable foods should be kept.

Vegetables and salad foods can be stored in the salad drawer. To ensure they are maintained in a crisp condition it may be necessary to wrap some foods in polythene bags eg. lettuce, watercress or herbs.

DOOR STORAGE

Storing items in the door liner can eliminate searching the main compartment. The lower door shelf should be used for the storage of heavier bottles whilst remaining shelves will accommodate fat, butter, small cartons and jars etc.

The two bottle stops are removable for cleaning (see fig. 15).

Enclosed storage compartments may be used to store dairy products and fats.

DEFROSTING YOUR FRIDGE COMPARTMENT

The defrosting of the larder refrigerator occurs automatically. There is a drain outlet situated at the back of the compartment, as indicated by a label on the inside wall. The drain outlet should be cleaned at regular intervals, see fig. 15.

IT IS IMPORTANT THAT THE DRAIN OUTLET IS KEPT CLEAR AT ALL TIMES, IF BLOCKED, CAREFULLY CLEAR IT USING A PIECE OF FLEXIBLE CURTAIN WIRE INSERTED INTO THE DRAIN OUTLET TO REMOVE BLOCKAGE.

FRESH FOOD STORAGE GUIDE

The recommended storage times of food are as follows:

Shelf Position

Top Shelves

	Storage Time
Fats	10 days
Hard Cheese	7-14 days
Cooked Meats, Poultry	2 days
Bacon	7 days

Middle Shelves

Milk and Cream	2-3 days
Soft Cheese	2-3 days
Eggs	2 weeks
Desserts With Cream/Custard	2 days
Pastry Products	3-4 days
Cooked Meat Pies/	

Sausage Rolls	2 days
Cooked Fruit	Up to 4 days
Bottom Shelves	
Stock and Gravies	Up to 4 days
Fresh Fish	Eat same day
Fresh Meats	3 days
Fresh Poultry	2 days
Sausages	Up to 3 days
Minced Meat, Burgers	1 day
Salad Drawer	
Green Vegetables	3-5 days
Salad Vegetables	3-5 days
Fresh Fruit	5 days

HELPFUL HINTS WHEN BUYING FOOD

1. Always ensure that fresh food you purchase, is of a good quality and in prime condition.
2. Shop at a reliable source and buy the 'freshest' looking packages, avoid shopworn labels or produce covered in dust.
3. Avoid buying frozen food if you cannot store it straight away. The use of an insulated container is advisable. When you arrive home place the frozen food in the freezer immediately.

To obtain the best results from your appliance, neither hot foods nor liquids which may evaporate, should be placed in the larder compartment.

- * Fruit and vegetables should be thoroughly cleaned and placed in the salad drawer.
- * Butter and cheese should be placed in special airtight containers or wrapped in foil or polythene bags to exclude as much air as possible.
- * Milk bottles should have a cap and be stored in the bottom shelf of the door.

YOUR FREEZER COMPARTMENT

The ❄️❄️❄️ symbol means that your freezer will store frozen food at -18°C (-0.4°F) or colder for long term storage and will also freeze fresh food. The freezer temperature is controlled automatically by the thermostat situated in the larder compartment or table top.

Due to different installations, methods of usage and weather conditions, adjustments to the temperature setting may be required.

These are best assessed against a temperature reading on a thermometer buried in the frozen food. Remember you must take your reading very quickly since the thermometer temperature will rise rapidly after your remove it.

FROZEN FOOD STORAGE

Your appliance has the following net storage volume:

Model "A" net storage volume 75.81litres (2.68cuft) *
weight of stored food 24.3kg (53.57lb).

Model "B" net storage volume 62 litres (2.19cuft)
*weight of stored food 19.84kg (43.8lb).

*This is a standard measurement and the actual capacity depends upon the density and sizes of the food. The above figures are based on an average daily density of 0.32Kg per litre (20lb per cuft).

Pre packed frozen food should be stored in accordance with the manufacturer's instructions for a 4star frozen food compartment and should be put in the freezer as soon as possible after purchase. Your freezer provides for long term storage which generally means up to 3 months, but the length of time can vary and it is important to follow the recommended times shown on packets of commercially frozen food.

Any opened packets of frozen food, should be rewrapped in airtight materials to prevent surface evaporation which causes drying or 'freezer burn'.

DEFROSTING YOUR FREEZER COMPARTMENT

Complete defrosting will in the course of time become necessary. This should be carried out if the frost build up cannot be all scraped away or if it begins to interfere with the food storage. Choose a time when the stock of frozen food is low and proceed as follows:

Take out the frozen food. Switch the appliance off at the mains and leave the door open.

Ideally the foods should be put into another freezer or refrigerator. If this is not possible, wrap it in a compact block, first in several sheets, newspapers or thick towels, then in a thick rug or blanket. Keep it in a cool place.

Defrosting will vary depending on whether the freezer compartment is at the top or bottom of the appliance.

With the freezer at the top. A defrost drain is situated in the bottom right of the freezer compartment, sealed from below (in the top of the refrigerator) by a plastic

IMPORTANT

If the temperature rises in frozen food because of:

- Non compliance with manufacturer's recommendations.
- Electric power failure.
- Due to defrosting.

Then recommended storage life may be reduced and storage times may not apply.

Frozen food which is allowed to thaw accidentally should either be used immediately or thrown away.

Alternatively if the food is uncooked and has not been completely defrosted it can be cooked and then refrozen.

NOTE

- Do not place sealed containers of carbonated liquids such as fizzy drinks into the freezer as it creates pressure on the container which may cause it to explode resulting in damage to the freezer.
- Ice cubes and ice lollies should not be consumed immediately after removal from the freezer as it may result in low temperature skin abrasions.

FREEZING FRESH FOODS

The Maximum quantity of fresh food you can freeze in any 24 hours is;

Model "A" 9kg (20lb),
Model "B" 4.5kg (10lb).

NOTE

Aim to check dates on packets and rotate food regularly. Although storage longer than recommended is not harmful, flavours and textures begin to deteriorate.

plug. Remove this plug by pulling it downwards (see fig. 16) and put a container under the opening to catch the defrost water. Keep the plug safely for re-use when defrosting is finished. Before complete defrosting, remove the bottom shelf in the freezer cabinet.

With the freezer at the bottom fold out the flip spout, put a suitable container under the spout to collect the defrost water, and leave the door open (see fig. 17).

Defrosting can be speeded up by putting bowls of hot (not boiling) water in the freezer and loosening the frost with a stiff bristle brush. After defrosting, clean and dry the interior as explained under "Cleaning and Care".

Remember: If the temperature of frozen food is allowed to rise during the defrosting period, its storage life may be shortened.

FOOD FREEZING GUIDE

	<i>Max. Storage Period</i>	<i>Method</i>	<i>Remarks</i>
MEAT Joints			
Beef	10-12 months	Remove additional fat. Cut to handy size, wrap thoroughly.	Pad bone ends.
Pork	6 months	Cut to hand size, wrap thoroughly.	ditto
Lamb	9 months	ditto	ditto
Steak	10-12 months	Open freeze or interleave with plastic film.	ditto
Chops	See Pork or lamb above	ditto	ditto
Veal Fillets	6-9 months	ditto	
Bacon, cured	6 weeks	ditto	Pack in handy meal portions.
smoked	1 month		
Sausages	6 weeks	Wrap tightly.	Pack in handy meal portions.
Minced meat	2 months	Wrap tightly.	Pack in handy meal portions.
Offal and tripe	3 months	Clean thoroughly, remove tubes, cores and fat, pack in small portions.	Make sure it is really fresh.
POULTRY			
Chicken	9-12 months	Clean in usual way, joint if necessary, wrap thoroughly.	Wrap giblets separately, pad bone ends. Do not stuff till ready.
Turkey	9-12 months	Clean in usual way, joint if necessary.	ditto
Duck, Goose	6 months	Clean in usual way, joint if necessary.	ditto
Giblets	3 months		Wrap separately from bird.
Game	6 months	Hang before freezing.	Cook immediately after thawing.
FISH			
All types	3 months	Clean, descale, discard head and tail, wrap separately.	Must be fresh.
Trout	3 months	Clean, descale, discard head and tail, wrap separately.	Must be fresh.
Salmon	3 months	Clean, stuff with greaseproof paper for shape retention or cut into steaks, cutlets or fillets.	Must be fresh.
VEGETABLES			
Mushrooms	3 months	Leave button mushroom whole, slice larger ones. Trim stalks, wash, dry thoroughly. Freeze open (or sautéed in a little butter till partially cooked then freeze).	Pack in boxes.
Potatoes	3 months	New potatoes and chips can be frozen raw. Otherwise cook partially in one of usual forms, cool then freeze.	
Beans (Broad, French or runner)	12 months	Peel or pod and wash, top and tail. Cut large beans into shorter lengths or slice.	Blanch for 2 mins., cool for same time in iced water then freeze.

	Max. Storage Period	Method	Remarks
Carrots	12 months	Use small ones, Prepare by scraping top and tail.	Blanch for 3-4 mins.
Cauliflower	12 months	Break up the florets and wash.	Blanch for 3mins. Add lemon juice to water to improve whiteness.
Spinach	12 months	Wash thoroughly. remove thicker veins.Chop if liked.	Blanch a few leaves at a time, for 2 mins.
Sprouts	12 months	Use only small ones. Remove outer leaves.	Blanch for 3mins, - medium 1½ mins.- small.
Root crops	12 months	The younger the better. Peel and slice or freeze whole.	Blanch for 3-5 mins.
FRUIT			
Apples	9-12 months	Freeze either of two ways: as puree-stew with little water, beat to smooth pulp, sweeten to taste, blanch for two mins., drain and cool. Pack tightly in layers with a little dry sugar sprinkled between, if so desired; or soak in slightly salted water for ten minutes, dry and freeze.	Freeze in small quantities Pack in plastic containers, leaving 1.5cm (½ in.) headroom
Apricots	10-12 months	Preferably remove stones, but leave skins on. Pack in syrup 200-400g (½-1lb.) sugar to 550ml (1 pint) of water, making sure fruit is covered.	Pack in plastic containers leaving 1.25-2.5cm (½-1in.) headroom
Cherries	12 months	ditto	ditto
Damsons	12 months	ditto	ditto
Plums	9 months	ditto	ditto
Gooseberries	12 months	ditto	ditto
Blackberries	12 months	Either pack in syrup as above, or coat with caster sugar and pack in plastic containers. Also may be frozen open then pack in containers.	ditto
Currants	12 months	ditto	ditto
Raspberries	12 months	ditto	ditto
Strawberries	12 months	ditto	ditto
Peaches	10 months	Cover with boiling water for 1 minute then cool by dipping into cold and peel carefully. Cut into halves, removing stone. Use syrup method of packing and freezing.	keep fruit submerged in syrup, place crumpled greaseproof paper on top, so there is no room between the surface of the liquid and the lid.
DAIRY PRODUCTS			
Eggs whole	6 months	Pack leaving headspace, beat slightly.	Do not freeze eggs in their shells as they will crack.

	Max. Storage Period	Method	Remarks
Egg Whites	6 months	Beat slightly, place whites in small containers just a few at a time.	
Egg Yolks	6 months	As for whites, but to prevent coagulation mix with 1/4 tsp. salt or 1/2 tsp. caster sugar to every two yolks.	Use for savoury or sweet dishes, label so that correct yolks are used.
Butter	6 months (unsalted) 3 months (salted)	Wrap bought butter in foil and freeze.	
Cream Whipping and Double only	3 months	Must first be beaten slightly before freezing. Rosettes of whipped cream can be piped onto silicone paper and open frozen.	Allow slight room for expansion in the container. Pack in layers.
Cheese	4 months (soft) 3-4 months (hard)	Wrap all varieties tightly in foil.	Hard cheese stores much better when grated.

BAKED ITEMS Wrap in foil or polythene bags

Bread (Freshly baked)	1-2 months	Wrap and freeze.
Cakes, plain	6 months	Wrap and freeze.
Cakes, iced	3 months	Freeze without wrapping, then wrap and store in polythene.

PREPARED FOODS

Stews	2 months	May be frozen quite satisfactorily in a polythene bag.	Place bag inside a square plastic or cardboard box to shape the contents into bricks which save space in freezer.
Sauces	4 months	Freeze in quantities of 275ml (1/2 pint) A little extra liquid may be required, when you come to use it.	Egg based sauces are unsuitable.
Full courses	3 months	Assemble individual helpings on specially constructed aluminium trays, then cover with foil. To re-heat leave the cover on and put in the oven for about 45 minutes at 200°C/Mark 6.	Cover slices of meat with gravy to prevent drying out.

HEALTH AND SAFETY GUIDELINES

Because of consumer demand, preservatives have been removed from many pre-prepared food. This together with the changes in shopping habits to a once a-week shop, mean that safe handling and storage of food is even more important than ever.

The following tips should help you to ensure that the food in your home is in as perfect condition as possible.

- Keep the time between buying chilled food and placing it in your fridge as short as possible. Tests showed that the temperature of 1 litre of orange juice rose to 22°C in an hour between the supermarket and home. It then took 11 hours to get down to 7°C in the refrigerator.
- Keep the refrigerator door closed as much as possible. Remember that warm air is flowing in as you are deciding what to have for tea!
- Do not push food together too much, try to allow air to circulate around each item.
- Cool cooked food as quickly as possible but do NOT place in the refrigerator or freezer until cool. (Leave food in a place as cool as possible in order that it can then be placed in the refrigerator or freezer as soon as possible).
- Do NOT mix raw and cooked meat, they must be in separate containers. Take care not to let the meat juices drip onto other food. If the meat does drip, remove everything and clean thoroughly.
- Do not store food uncovered.
- The best way to defrost food is to put it in the refrigerator to thaw slowly.
- Remove suspect food from your refrigerator and clean the interior with a solution of bicarbonate of soda in warm water (5ml to 0.5 litre of water).
- Never allow spillages to dry and harden.
- Ensure that food placed in the freezer is dated and labelled and used in date order to ensure that food is consumed at its best.
- It is important that food is used before its 'best before' date.

Store eggs in the egg rack provided in the refrigerator door. Discard any broken or chipped eggs.

- Regularly check the refrigerator door seal to ensure that it is clean and free from bits and pieces.
- Always wash your hands with soapy water and dry them with a clean towel before handling food.
- Keep work surfaces clean and avoid cross contamination by not using the same work surface or knife, without washing them thoroughly in between.
- Use kitchen roll wherever possible for cleaning up food. If you use a dishcloth, be sure to boil it frequently.

In the event of a power failure causing the temperature within your freezer to rise, do not re-freeze the food without checking its condition. The following guidelines should assist you.

Ice Cream: Once thawed should be discarded.

Fruit & Vegetables: If soft should be cooked and used up.

Bread & Cakes: Can be re-frozen without danger.

Shellfish: Should be refrigerated and used up quickly.

Cooked Dishes: ie casseroles should be refrigerated and used up.

Large Pieces of Meat: Can be re-frozen providing there are still ice crystals remaining within them.

Small Joints: Should be cooked and can then be re-frozen as cooked dishes.

Chicken: Should also be cooked and re-frozen as a cooked dish.

CLEANING AND CARE

BEFORE any maintenance or cleaning work is carried out, DISCONNECT the appliance from the ELECTRICITY supply.

INTERNAL CLEANING

Clean the inside and accessories with warm water and bicarbonate of soda (5ml to 0.5 litre of water). Rinse and dry thoroughly.

NEVER USE DETERGENTS, ABRASIVE POWDERS, HIGHLY PERFUMED CLEANING PRODUCTS OR WAX POLISHES, TO CLEAN THE INTERIOR AS THESE WILL DAMAGE THE SURFACE AND LEAVE A STRONG SMELL.

Wash the outer cabinet with warm soapy water. Do NOT use abrasive products. Please Note: There are sharp edges on the underside of the product so care should be taken when cleaning.

Once or twice a year dust the condenser (black grille) and the compressor at the back of the appliance, with a brush or vacuum cleaner.

YOU MUST ENSURE THAT THE APPLIANCE IS SWITCHED OFF. An accumulation of dust will affect the performance of the appliance and cause excessive electricity consumption.

WHEN THE APPLIANCE IS NOT IN USE

When the appliance is not in use for long periods, disconnect from the electricity supply, empty all food and clean the appliance, leaving the doors ajar to prevent unpleasant smells.

REPLACEMENT OF INTERIOR LIGHTBULB

Should the interior light fail to work, first switch off the appliance and disconnect from the electricity supply, then replace the light bulb as follows:

Using a screwdriver remove the light cover by undoing the screw (retain the screw for later use). Then, pull the cover outward toward the middle of the cabinet. Unscrew the bulb and replace it with a new 15 watt E14 SES bulb.

The light is mounted in the roof of the cabinet on type A models (fig.18) and in the side of the cabinet on type B models (fig. 19).

Replace the light cover by sliding it into its original position and replacing the screw.

WHAT HAPPENS IF SOMETHING IS NOT WORKING?

BEFORE contacting your local Electricity Company Service Depot, check the following points:

The appliance does not work . . . Check that:

- * There is power at the socket.
- * Ensure that there is not a power cut by checking the household lights.
- * The fuse has not blown.
- * The air circulation passages are not covered.

Vibration or abnormal noises . . .

- * You may hear faint gurgling or bubbling sounds when the refrigerant is pumped through the coils of tubing at the rear, to the cooling plate/evaporator. When the compressor is on, the refrigerant is being pumped round, and you will hear a whirring or pulsating noise from the compressor. A thermostat controls the compressor, and you will hear a faint 'click' when the thermostat cuts in and out.

RATING PLATE

The rating plate is situated inside the cabinet. It gives the model and serial numbers which should be quoted in any communication. For future reference record the information below:

Model No:	
Serial No:	
Date of Purchase:	

The light does not come on . . . Check that:

- * The bulb is fitted correctly.
- * Replace the bulb if it has blown.

Other points to check . . . Check that:

- * Have you turned the thermostat to the correct setting?
- * Have doors been left open causing the temperature to rise?
- * Sometimes the freezer door will be difficult to open shortly after you have closed it. Don't worry this is due to pressure difference which will quickly equalise and allow the door to open normally.

If after the above checks, there is still a fault, call your local Service Depot.

In-guarantee customers should ensure that the above checks have been made as the engineer will make a charge if the fault is not a mechanical or electrical breakdown.

- * **Please note that proof of purchase is required for any In-guarantee service calls.**

Before contacting your local Service Depot, make a note of the make, model and date of purchase of your machine: the Service Depot require this information.

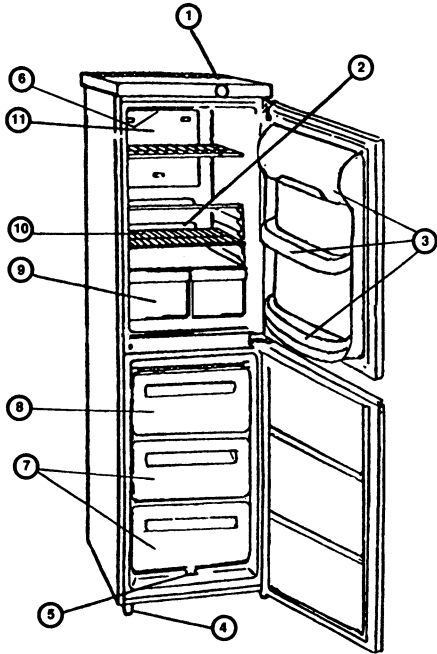

MODEL A

A

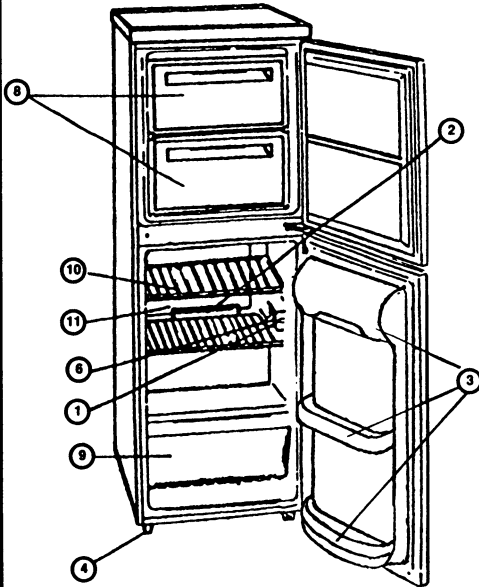

MODEL B

FIG 1

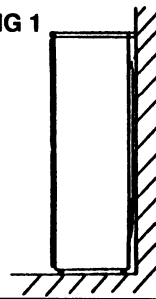

FIG 2

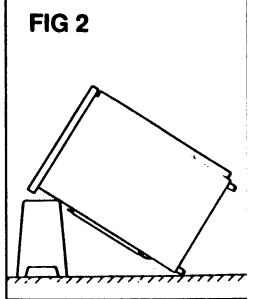

Fig. 7

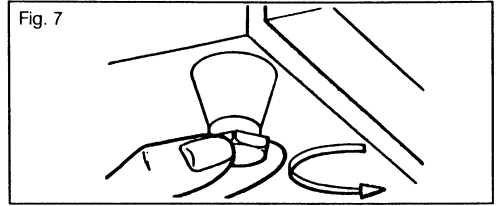

Fig. 8

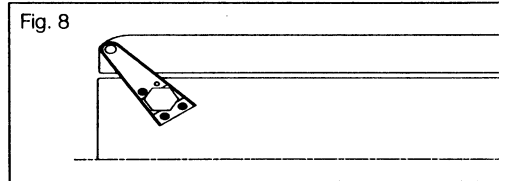

FIG 12

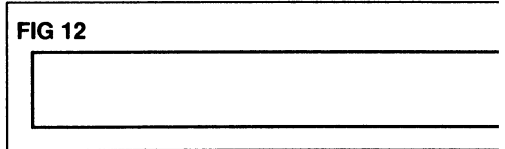

FIG 14

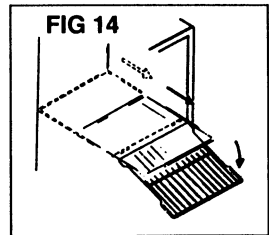
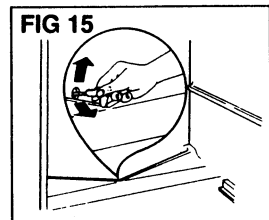
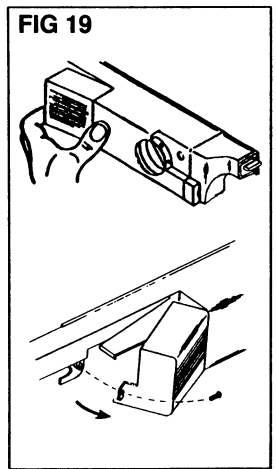
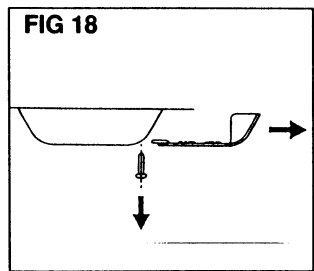
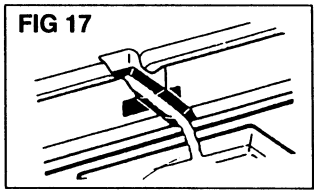
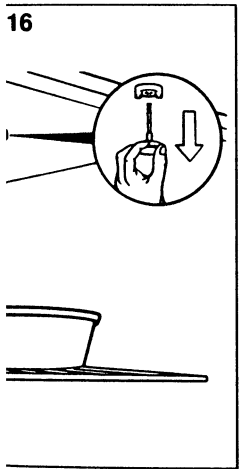
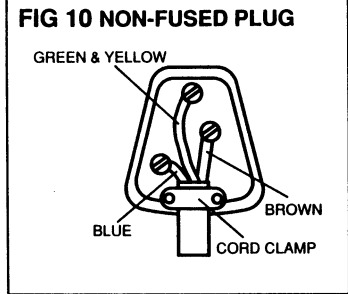
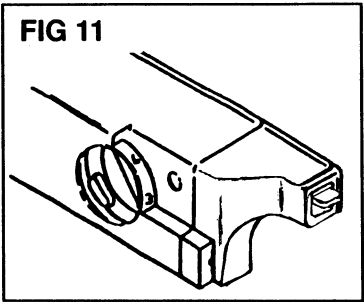
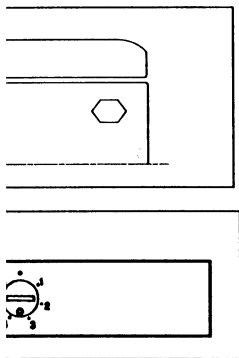
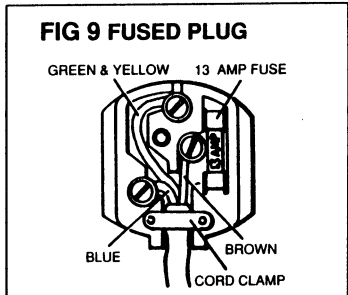
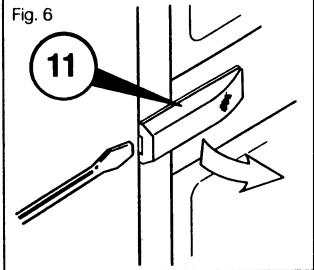
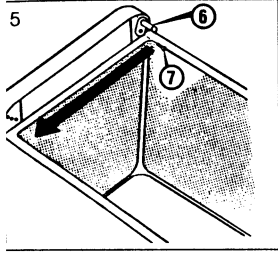
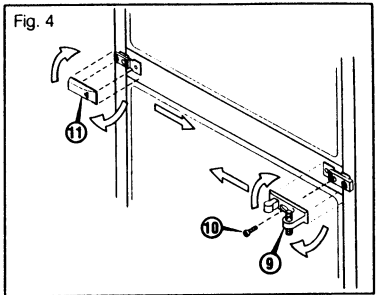
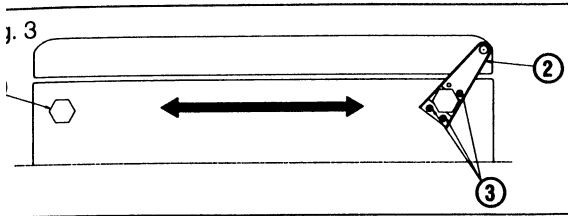

FIG 15





Free Manuals Download Website

<http://myh66.com>

<http://usermanuals.us>

<http://www.somanuals.com>

<http://www.4manuals.cc>

<http://www.manual-lib.com>

<http://www.404manual.com>

<http://www.luxmanual.com>

<http://aubethermostatmanual.com>

Golf course search by state

<http://golfingnear.com>

Email search by domain

<http://emailbydomain.com>

Auto manuals search

<http://auto.somanuals.com>

TV manuals search

<http://tv.somanuals.com>