

Electro-Voice®
 TELEX/EVI Audio
 1 Telex Drive
 Morrilton, Arkansas 72110
 Phone: 1-800-685-2606
 FAX: 501-354-1118

SERVICE DATA

EVID C4.2

(301258-000)

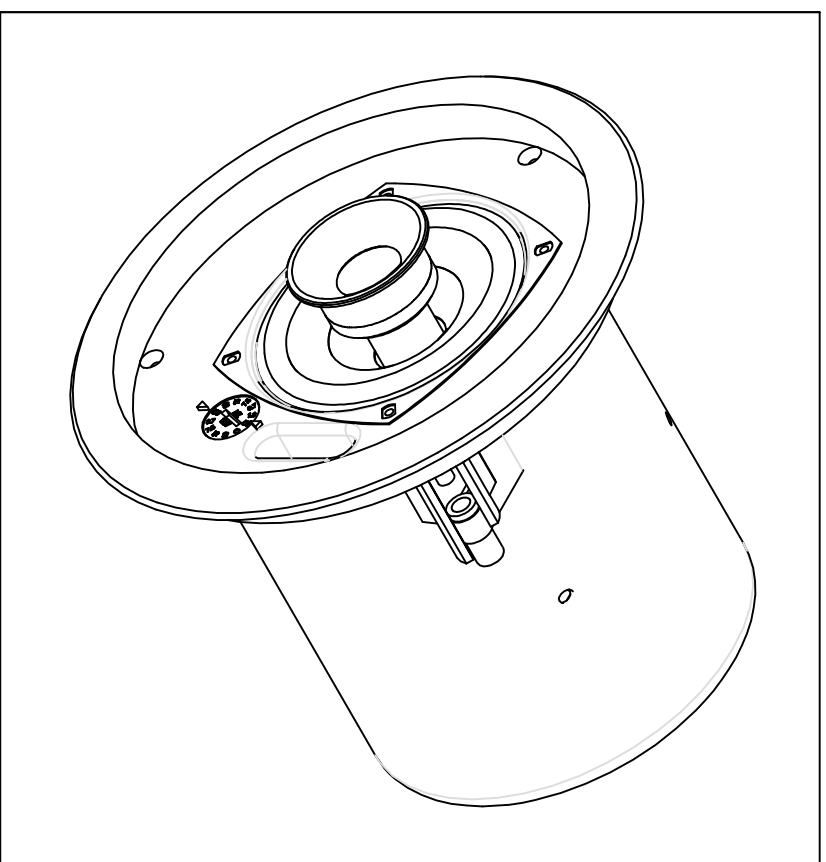

PARTS LIST

QUANTITIES SHOWN ARE FOR ONE COMPLETE UNIT, UNITS COME PACKAGED IN PAIRS

ITEM	EVID C4.2 301258-000 PART NO.	QTY.	DESCRIPTION
1	560182-000	1	ENCLOSURE S/A, EVID C4.2
2	560199-000	1	WOOFER, 4" COAX, EVID C4.2
3	560201-000	1	CROSSOVER S/A, WITH 30W TRANSFORMER, EVID C4.2
4	560184-000	1	CROSSOVER S/A, EVID C4.2
5	559019-000	1	TRANSFORMER, 30W, EVID C4.2 AND C8.2
6	545093-000	1	TRANSFORMER SWITCH, EVID C4.2 AND C8.2
7	539173-000	1	CONNECTOR, REMOVABLE INPUT, PHOENIX TYPE, EVID CEILING SPEAKERS
8	500618-000	3	MOUNTING TABS, EVID CEILING SPEAKERS
9	581006-000	3	SCREW, M4 X 52MM, BLK ZINC
10	500619-000	1	TAP SELECTOR, TRANSFORMER SWITCH, EVID C4.2 AND C8.2
11	570208-000	1	LABEL, ENCLOSURE, EVID C4.2
12	570206-000	1	LABEL, INPUT, EVID CEILING SPEAKERS
13	66121	2	TUBING, HEAT SHRINK, TYP VFP-3M BLK, 3/16DIA [CUT TO 2.5" LENGTHS]
14	500612-000	2	TILE RAIL, EVID CEILING SPEAKERS
15	500611-000	1	C-BRACKET, EVID C4.2
16	560183-002	1	GRILLE S/A, EVID C4.2
17	63371CP	4	SCR, 8-15 X 1/2, PAN HD, XREC, TYPE A, STL, BLK ZINC
18	581025-000	2	SCR, M4-0.7 X 25MM, ZINC CHROMATE
19	581026-000	5	SCR, M4-0.7 X 10MM, ZINC CHROMATE
20	581027-000	2	SCR, M4-0.7 X 18MM, ZINC CHROMATE
21	586004-000	4	NUT, M4-0.7, ZINC CHROMATE
22	3980AE	4	WASHER, #8, 7/16 X 3/16 X 3/64" (CHTD ON 3980)
23	584007-000	2	WASHER, RUBBER, .60" OD X .20" ID X .12" T, EVID CEILING SPEAKERS
24	581028-000	2	SCR, M4 X 10MM, ZINC CHROMATE

ADHESIVES

A	97207	LOCTITE® "C" 24231 50 ML BTL
---	-------	------------------------------

NOTES:

ITEM 6 ASSEMBLED INSIDE CAN BEHIND ITEM 10

TO REPLACE WOOFER:

1. REMOVE WOOFER SCREWS (ITEM 17) FROM BAFFLE.
2. DISCONNECT WOOFER AND TWEETER LEADS. FOR TWEETER LEADS, CUT SHRINK WRAP AROUND THE LEADS, BEING CAREFUL TO NOT CUT THE WIRES.
3. PUT A HEAT SHRINK TUBE (ITEM 13) OVER EACH OF THE CROSSOVER'S TWEETER LEADS (ITEM 4) (SEE FIG. 1) AND RECONNECT THE CROSSOVER TO THE TWEETER AND WOOFER LEADS, MAINTAINING THE CORRECT POLARITY.
4. SLIDE THE HEATSHRINK TUBES (ITEM 13) IN PLACE, COVERING BOTH TWEETER LEADS. SHRINK TO FIT TIGHTLY WITH HEAT GUN (SEE FIG. 2).
5. SCREW WOOFER BACK ON TO BAFFLE.

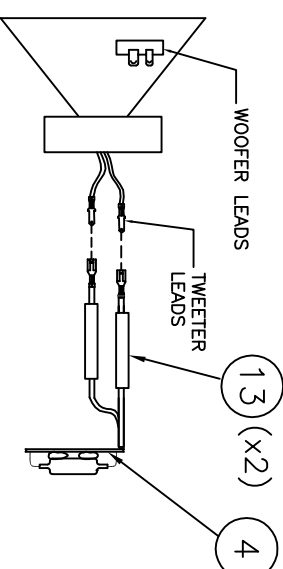

COAX SPEAKER — FIG. 1

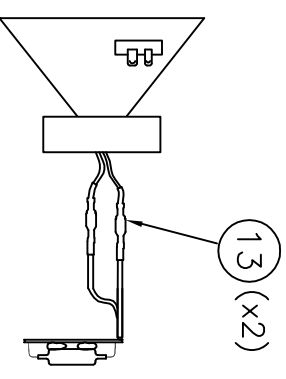

REATTACHED TWEETER LEADS — FIG. 2

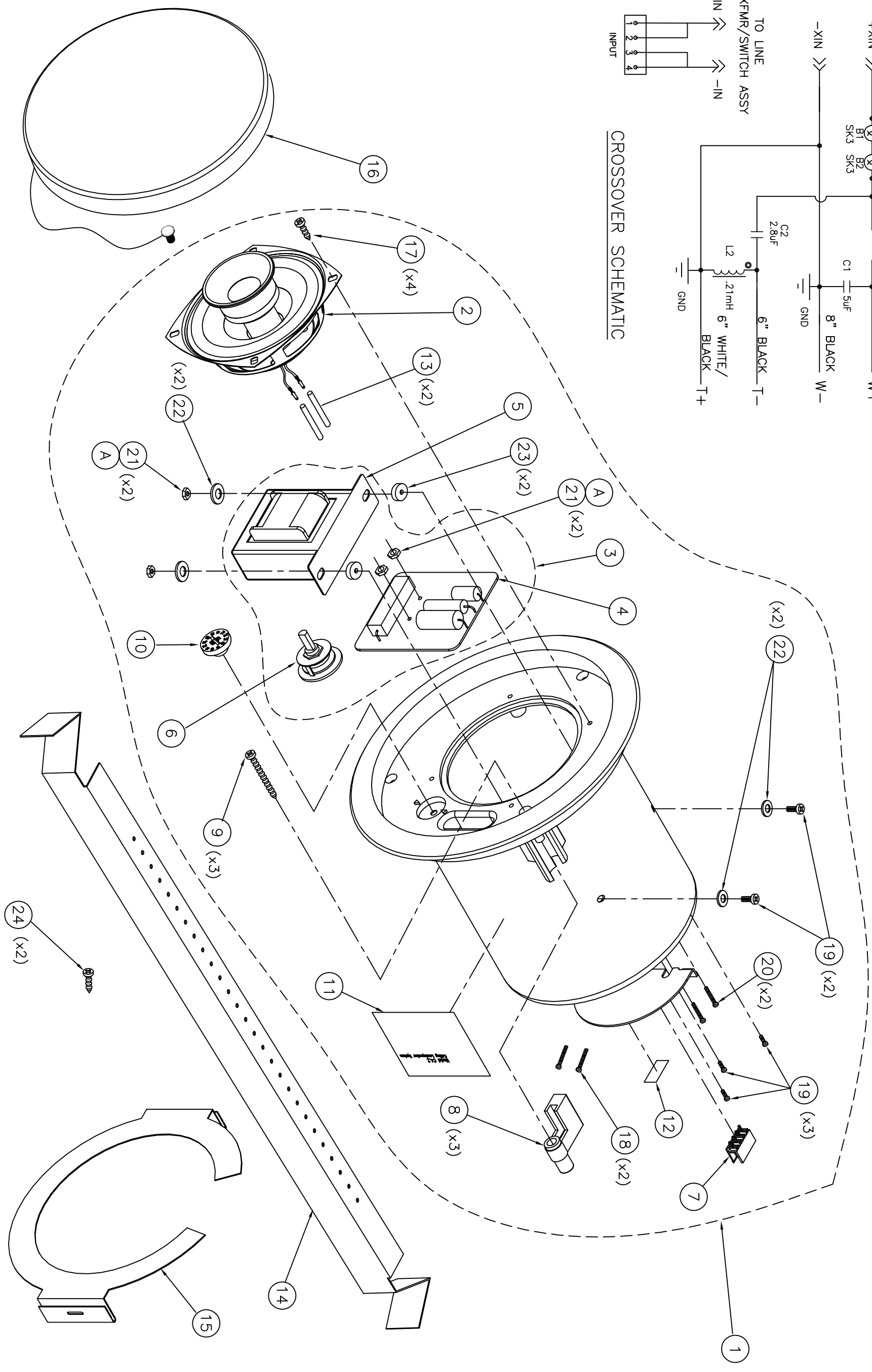
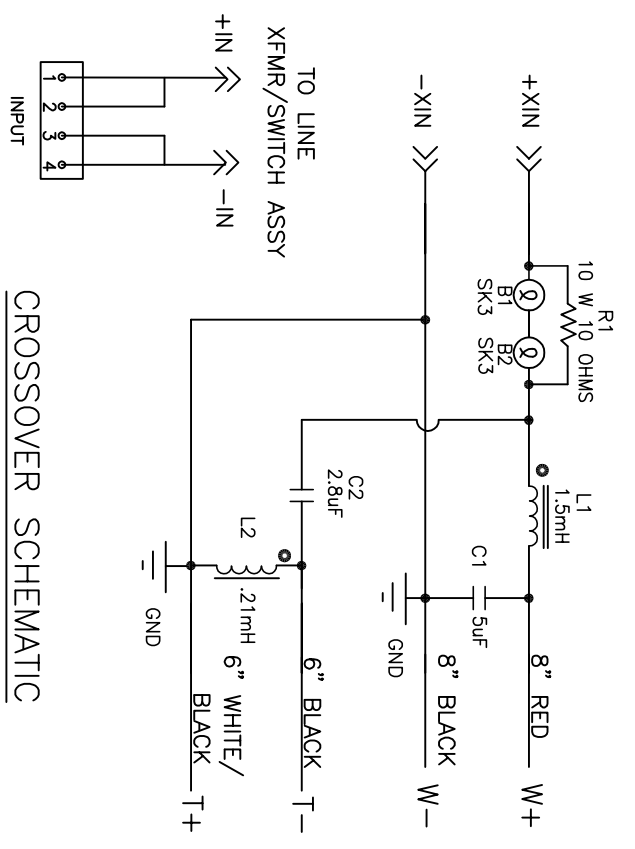

Free Manuals Download Website

<http://myh66.com>

<http://usermanuals.us>

<http://www.somanuals.com>

<http://www.4manuals.cc>

<http://www.manual-lib.com>

<http://www.404manual.com>

<http://www.luxmanual.com>

<http://aubethermostatmanual.com>

Golf course search by state

<http://golfingnear.com>

Email search by domain

<http://emailbydomain.com>

Auto manuals search

<http://auto.somanuals.com>

TV manuals search

<http://tv.somanuals.com>