

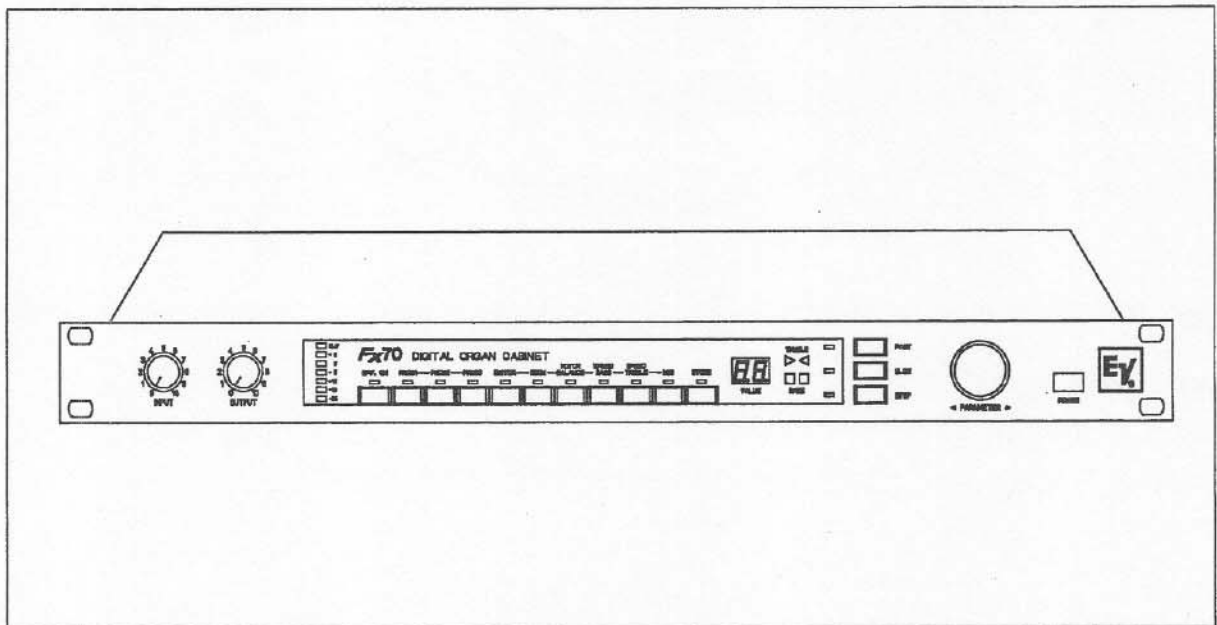

# Electro-Voice®

## OWNER'S MANUAL



**Fx 70**

**Digital Organ Cabinet**

## 1. INTRODUCTION

We should like to start by thanking and congratulating you for purchasing the Digital Organ Cabinet Simulator Fx 70 from Electro Voice.

The Fx 70 enables supreme quality, natural-sounding digital reproduction of the typical effects of loudspeaker rotor systems. The various programs make for prime simulation of the original cabinets on which it was based. All the originals' typical properties such as different frequency responses, rotor speeds, coloration, start-up and decay times have all been determined via precise measuring techniques and subjected to psycho-acoustic analysis. In the Fx 70 the 24 bit signal processor ARS-10 calculates the identical algorithms, thus providing perfect simulation of the original sound in stereo.

A room simulation can be allocated to any of the programs which calculates the reflections of the rotating loudspeaker depending on the room type and size and adds the effect. This procedure is significantly more accurate and sounds a lot more natural than reverberating the effect via a random echo program.

Preferential room simulations have been allocated to each program. These can, however, be changed. All function keys have status LED's which signalize the current operating mode quickly and clearly. A special display indicates the rotor speeds. The parameters are edited via a rotary encoder, the respective values of the selected parameters being indicated with a 2-digit display. Alterations of the parameters can be stored under one of three program memory places.

It goes without saying that remote control of the Fx 70 is also possible via MIDI. The unit is thus equipped with IN-OUT-THRU sockets for integration into a MIDI system. The power supply of the Fx 70 adapts automatically to mains voltages of 90 - 250 V (50-60 Hz).

This user's manual provides a wealth of information about the Fx 70. Please read it through carefully and we guarantee you immense pleasure with your new Digital Organ Cabinet Simulator Fx 70 from Electro Voice.

### IMPORTANT NOTES

**ATTENTION:** This unit must be protected from damp because of fire risk and the possibility of electric shocks.

1. Make sure that nothing, especially no metal objects, are inserted into the device. This could result in a severe electric shock or malfunction.
2. If the unit is subjected to extreme fluctuations of temperature, e.g. on being transported from outside to a heated room, condensation can form. The unit should not be used until it has reached room temperature.
3. If water or any other liquid is spilt on to the unit accidentally, the unit should be switched off immediately and taken to a servicing facility to be checked.
4. Make sure that the unit is always well ventilated and never exposed to direct sunlight.
5. Do not use sprays to clean the unit as they have a detrimental effect on the unit and could ignite suddenly.

# CONNECTIONS AND CONTROLS

## 2. CONNECTIONS AND CONTROLS

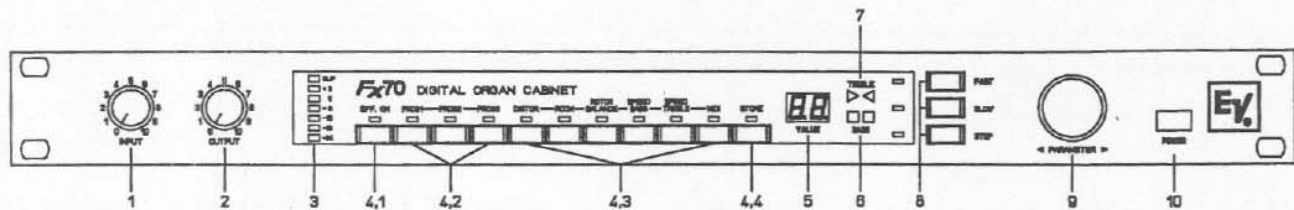

### 2.1 FRONT PANEL

#### 1 INPUT CONTROL

This input control serves to alter the level of the input signal to achieve optimum modulation of the Fx 70 (0 dB on the level indicator). (Also see 17 HI/LO).

#### 2 OUTPUT CONTROL

The output control serves to change the output level of the Fx 70 to drive subsequent appliances with the optimum level.

#### 3 LEVEL INDICATOR

This serves for level control of the input signal. The optimum setting is 0 dB.

A further feature is the Peak/Hold function which facilitates levelling.

#### 4.1 EFFECT ON

switches between the original signal (LED off: Input > Output) and Effect signal (LED On: Input > Effect > Output).

#### 4.2 PROG 1, PROG 2, PROG 3

trip each other and select one of the three cabinet simulations. Each program uses different parameter values (ROTOR- SPEED, BALANCE, various rooms, distortion,) and different sound settings (Equalizer).

These programs can be stored with altered parameters.

#### 4.3 PARAMETERS and MIDI

The keys Distortion, Room, Rotor-Balance, Rotor-Speed Bass, Rotor-Speed Treble and Midi trip each other (respective Status LED lights up) and select the access of the rotary encoder (9) with Display (5) to the respective function.

#### 4.4 STORE

This key serves to store the current setting on one of the three program memory places.

Pressing the key a little longer time deletes the user programs and loads the factory presets (factory programs) on to all three program memory places.

#### 5 UNIVERSAL DISPLAY

This two-digit display has different meanings, depending on the function selected (Status LED). If MIDI has been selected, this is shown on the display, parameter value display, MIDI received, option numbers and values.

The display goes off after 10 seconds.

The display is turned on either by pressing or turning the rotary encoder (9) or by pressing one of the keys (4.3).

#### 6 ROTOR DISPLAY

This display allows a visual check of the bass rotor of an organ cabinet.

#### 7 ROTOR DISPLAY

This display allows a visual check of the treble rotor of an organ cabinet.

#### 8 STOP, SLOW, FAST

This switches the rotor speed for treble and bass cabinets into one of the three steps.

#### 9 ROTARY ENCODER WITH KEY

The meaning of this key depends on the function selected (Status LED). If MIDI has been selected, the MIDI channel is altered, parameter value control, option numbers and value control.

Pressing and turning this encoder at the same time accelerates settings.

Pressing the encoder briefly makes the display (5) brighter.

#### 10 POWER SWITCH

This serves to switch the Fx 70 on or off.

## 2.2 REAR PANEL

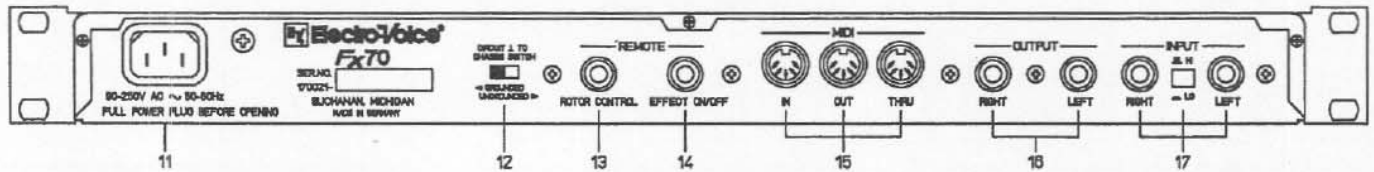

### 11 Mains socket

The enclosed Euro mains cable is connected here to put the Fx 70 into operation. The Fx 70 is equipped to deal with mains voltages between 90 V and 250 V and is thus not affected in any way by disturbances caused by fluctuating mains voltages.

### 12 Groundlift switch

This serves to prevent hum loops. If the Fx 70 is operated in a 19" rack together with other appliances, the switch should be set at GROUNDED. If the Fx 70 is operated together with other equipment with differing earthing potential, the switch should be set at UNGROUNDED.

### 13 Remote Socket ROTOR CONTROL

A foot switch FS 223 (optional accessory) can be connected here to switch over the rotor speeds in three steps (from Stop, Slow and Fast).

### 14 Remote Socket EFFECT ON/OFF

A foot switch FS 12 (optional accessory) can be connected to this socket to switch over between the original signal (Input > Output) and effect signal (Input > Effect > Output).

### 15 MIDI sockets (IN/OUT/THRU)

The output of a MIDI unit (keyboard, computer) can be connected to the MIDI IN socket, thus enabling remote control of all functions (keys, parameters...). Up to 38 parameters can be changed via MIDI IN (Sysex).

The input of a MIDI unit can be connected to the MIDI OUT socket. All settings and activities (keys, parameters ...) are issued at this socket and can be evaluated to control the Fx 70. (Sysex).

All data received via MIDI are transmitted in an unchanged format at the MIDI THRU socket.

Please turn to chapter 7 for further details.

### 16 Sockets OUTPUT LEFT/RIGHT

These are the Fx 70's stereo outputs. The output level can be altered via the output control (2). If only one of the sockets is used, a MONO sum is obtained from the left and the right output.

The optimum room sound simulation of an organ cabinet can only be achieved if both outputs (stereo) are used.

### 17 Sockets INPUT/LEFT/RIGHT and selector switch HI/LO.

These are the Fx 70's stereo inputs. The selector switch is used to switch between the LO input (+0dBm) and the HI input (- 20dBm). To feed in a MONO signal it is sufficient to connect only one of the two input sockets.



# SETTING UP THE Fx 70

## 3. SETTING-UP THE Fx 70

To achieve the best possible results, your Fx 70 must be connected correctly. For start-up purposes use the enclosed Euro mains cable to connect the mains socket and the Fx 70.



### 3.1 Mono in/Mono out

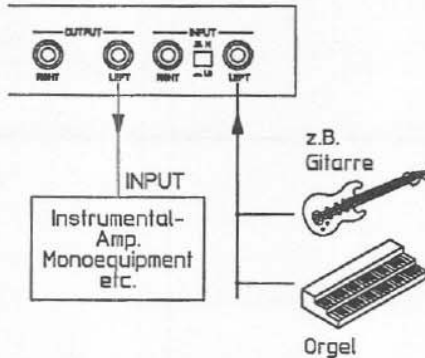

### 3.2 Mono in/Stereo out

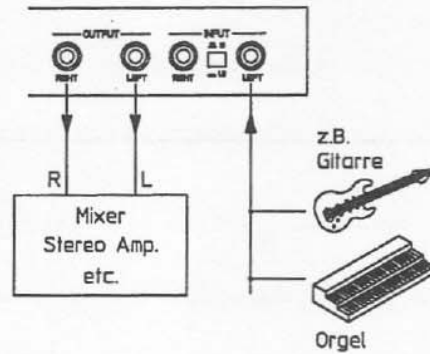

### 3.3 Stereo in/Stereo out

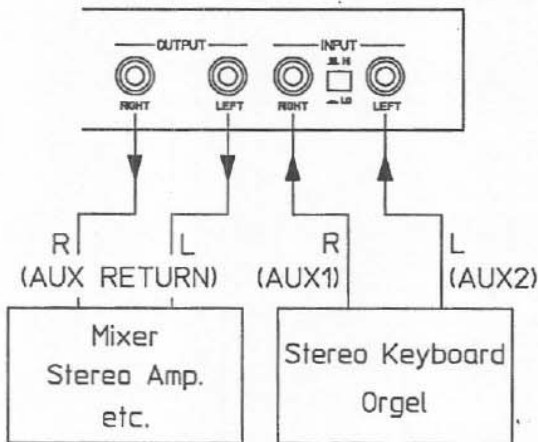

### 3.4 Position of the Groundlift switch

The groundlift switch serves to avoid hum loops. It must be positioned appropriately, depending on the operating mode in question.

### IMPORTANT!

- Some keyboards feature "stereo outputs" which are not mono-compatible. The two outputs sometimes only differ by a phase shifting on the second channel. This phenomenon is sometimes also referred to as "quasi-stereophone".
- As the rotor effects of both inputs are taken into consideration (summed), this can lead to fluctuating amplitudes or cancellations of the signal.
- This situation can be remedied by connecting one keyboard output with one of the Fx 70 inputs.
- Always use well-screened audio cables.
- To avoid loss of trebles, the cables should not be longer than 10 metres. This especially applies to those leading to the inputs.
- Never position the unit directly under or on a powerful amplifier, TV monitor or the like, as the leakage field of the transformers pertaining to such appliances can cause hums influence into the electronics of the Fx 70.

**UNGROUND:** If the Fx 70 is operated with other appliances which have a different earthing potential.

**GROUND:** If the Fx 70 is operated together with other units in a 19" rack.

CIRCUIT 1 TO  
CHASSIS SWITCH



◀ GROUNDED  
UNGROUND ▶

## 4. START UP

### 4.1 SWITCHING THE UNIT ON

1. Switch the Fx 70 on via the POWER switch (10).



2. The unit is now in switched on status. The last program (1-3) stored via STORE appears, the last MIDI channel or MIDI OFF stored via STORE is selected, parameter ROTOR BALANCE is selected, Display (5) briefly indicates the software version number (e.g. 2.0) and is then dark, Effect is switched ON and the rotors are at a standstill (STOP).

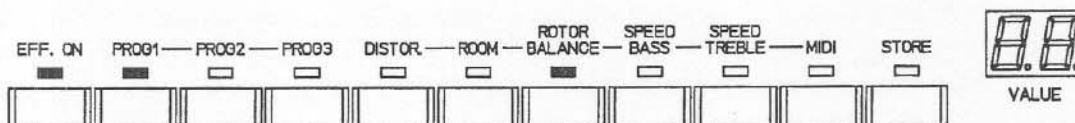

3. The Fx 70 is subsequently ready for operation.

### 4.2 SETTING LEVELS

1. First adjust the setting of the INPUT selector switch according to the equipment connected.
2. Whilst you are setting the level with the INPUT control (1), constantly check the maximum indication on the LEVEL DISPLAY (3). The optimum value is 0 dB. If the level range should be inadequate, press the INPUT selector switch (at the rear) to HI/LO position. The CLIP LED indicates internal overloading and should not be lit up on any account.

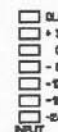

**LO:** This range is selected for low levels such as guitar or bass guitar.

**HI:** This range is selected for medium to high levels such as AUX OUTPUT, audio equipment with line level.

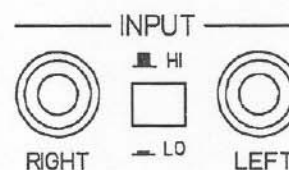

# OPERATION

## 5. OPERATION

### 5.1 EFFECT ON/OFF FUNCTION:

This key switches between the original signal and the effect signal. The level setting (Input/Output control) works for both functions.

A foot switch and MIDI can also be used for switching over between the two signals.

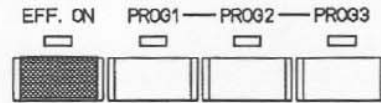

### 5.2 PROGRAM SELECTION

Pressing one of the three program keys briefly loads the respective cabinet simulation. The according LED lights up.

Pressing one of the three program keys long (3 sec.) loads the factory preset to that particular program place and calls it up. The LED fades briefly to serve as a visual signal!! A program stored on that program place is thus deleted.

Further factory presets can also be loaded (see MIDI and OPTION).

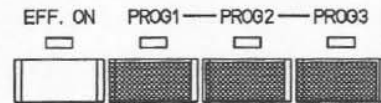

**Note:**

The factory presets vary in as many as 40 parameters.

### 5.3 EDITING PARAMETERS:

If one of the parameter keys is pressed, its value is indicated on the two-digit display. The corresponding Status LED lights up. The rotary encoder (9) can be used to alter the setting and takes immediate acoustic effect. The number range depends on the parameter selected.

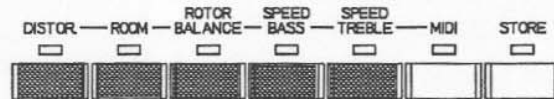

**Note:**

The rotary encoder is a fine detent knob with an integrated key. It can be turned infinitely to left or right. It works as an electronic counter which counts one step further every time it is turned one increment. Keeping the key pressed down whilst turning means that 10 steps are counted per increment.



### 5.4 STORING PROGRAMS

Pressing the STORE key causes the Store Status LED to flash on and off. Pressing one of the 3 program keys stores the current setting in question under this program number. The LED's on the front panel fade briefly to serve as a visual signal of this phenomenon.

A program can only be stored within 5 seconds of the STORE key (LED's flash on and off) so as to prevent unintentional programming.

Pressing the STORE key longer (3 seconds) restores the factory presets in all three program places. The LED's on the front panel fade briefly to provide a visual signal. The MIDI-channel respectively mode will be switched to OMNI-mode(ON),

**This deletes a program stored under one of these program places.**

**Note:**

Any changes to parameters (front panel, MIDI, OPTION) are also stored.  
The POWER ON status is re-defined by the STORE function. See chapter 4.1.

Further factory presets can be accessed via MIDI and OPTION.

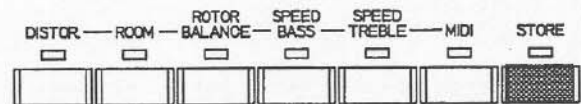

### 5.5 DESCRIPTION OF THE PARAMETERS

When one of the parameter keys is pressed, its Status LED lights up briefly and the parameter can now be changed via the rotary encoder (9). The respective value can be checked by consulting the display (5). Parameters can also be set via MIDI.

**DISTOR:**

The Fx 70 has an integrated distorter which creates tube-like distortion sounds.

The value 0 switches the distorter off, higher values increase the distortion factor.

**ROOM:**

This parameter is used to set a room simulation. The value 0 switches the room effect off. Higher values correspond to larger rooms.

The simulation is not effected by reverbing the signal but the room acoustics are reproduced depending on the position of the cabinet rotors. The cabinet stands with the back wall near to a room limitation (wall). The listener is at the front of the cabinet. This permits a natural sounding simulation of the acoustics of rotor cabinets in various rooms.

**Note:**

Many parameters which also contribute to the characteristics of rooms can be changed via MIDI (Sysex) or OPTION. Examples include the frequency response or the distance between the listener and the cabinet.

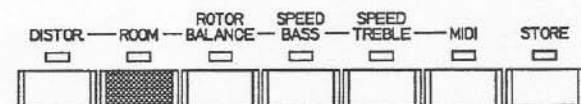
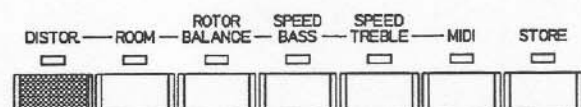

# OPERATION

## ROTOR BALANCE

This control determines the acoustic balance between the treble and bass sections. The value 0 supplies the same output level for both rotors. Negative values (-) emphasize the bass rotor; positive values (+) emphasize the treble rotor. This parameter is sometimes called Volume Bass or Volume Treble on some cabinets.

**Note:**

The X-over frequency of both rotors can be altered via MIDI (Sysex) or OPTION.

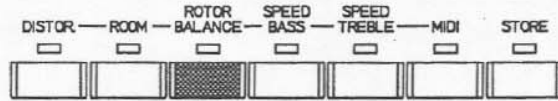

## SPEED-BASS

This serves to alter the rotation speed of the bass rotor. This setting affects the FAST and SLOW speeds, thus maintaining a constant ratio between the two.

**Note:**

The ratio between FAST and SLOW can also be altered via MIDI (Sysex) and OPTION.

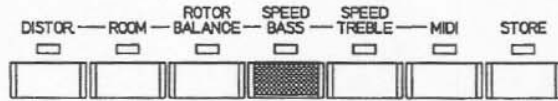

## SPEED-TREBLE

This serves to alter the rotation speed of the treble rotor. This setting affects the FAST and SLOW speeds, thus maintaining a constant ratio between the two.

**Note:**

The ratio between FAST and SLOW can also be altered via MIDI (Sysex) and OPTION.

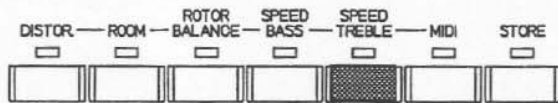



## 6. OPTION

In the OPTION MODE it is possible to alter many additional parameters and settings. These corrections can be stored into one of the three programmes.

Examples include: sound impression via multi-band equalizer, additional factory presets, ratio between the rotation speeds FAST and SLOW, rotation reversal, modulation depth for amplitude and frequency, room size...

These possibilities are described in this chapter. MIDI users (Sysex) can control them from their computers (see MIDI Chapter 7). A table illustrating this topic is included at the end of the chapter.

### 6.1 ACTIVATING THE OPTION MODE

This is called up by pressing both the SPEED BASS and the SPEED TREBLE keys for three seconds. The Status LED of the SPEED BASS key begins to flash on and off and a figure (control number) appears on the display (5).

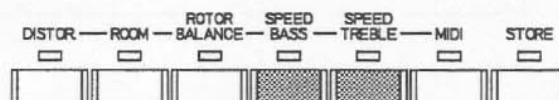

### 6.2 OPERATION OF OPTION MODE

Pressing the key SPEED BASS (Status LED flashes on and off) means that a parameter or a function can be selected via the rotary encoder (9). The corresponding number is shown on the display (5).

Pressing the key SPEED TREBLE (Status LED flashes on and off) means that the value (control setting) of the parameter selected is shown on the display (5). This setting can be altered via the rotary encoder (9). The control range depends on the parameter selected.

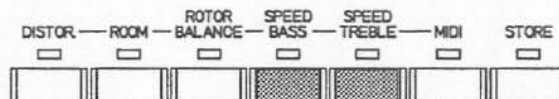

### 6.3 CONCLUDING OPTION MODE AND STORING

Pressing either keys "DISTORTION", "ROOM", "ROTOR BALANCE" or "MIDI" switches the OPTION MODE off.

The edited settings are stored by pressing the STORE key. The STORE status LED and the three program LED's begin to flash on and off and pressing one of the program keys stores the current setting in question. This is how the OPTION mode is concluded. The program key must be selected within 5 seconds as the storage mode is interrupted otherwise. (flashing ceases).

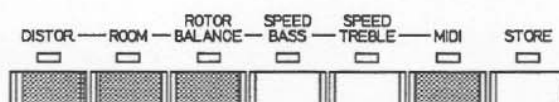

### 6.4 FUNCTION 00 = ADDITIONAL FACTORY PRESETS

Press the key "SPEED BASS", set 00 with the rotary encoder, press the key "SPEED TREBLE" and select a preset via the rotary encoder (see current preset list). The preset which is selected can be listened to immediately, can be altered (see OPERATION OF OPTION MODE) and stored on one of the three program places, (see CONCLUDING OPTION MODE AND STORING).

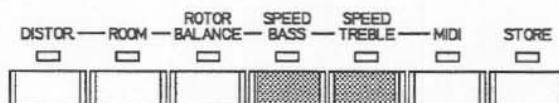

## OPTION

### 6.5 OPTION-Parameter 01 - 42

#### NOTE:

Most of the following parameters exist independently for the bass rotor and treble rotor. To ease the adjustment it is best to turn the "BALANCE" control to +9 or -9 respectively.

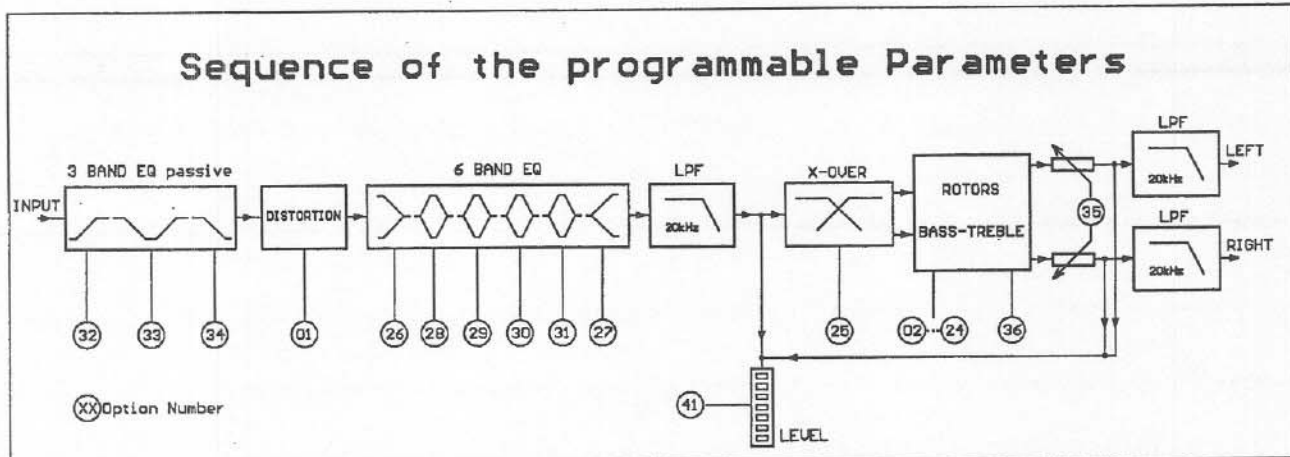

This is so as to recognize the effects of editing these parameters (e.g. level display, non-linear functions...)

### GENERAL PARAMETER

The general parameters (1-5) influence the basic sound characteristic of the unit and therefore can be accessed in normal operating mode just pushing the respective front panel buttons.

#### **PARAMETER 01 = DISTORTION**

This tube-like distorter precedes the rotors and can reach values ranging between 0 and 15. (15 = high distortion factor). See also DESCRIPTION PARAMETER page 5-2.

#### **PARAM. 02 = ROOM**

Possible values range between 0 (no reflections) and 15 (large room). See DESCRIPTION PARAMETER, page 5-2.

#### **PARAM. 03 = ROTOR BALANCE**

Possible values range between -9 (high bass content) to +9 (high treble content). See DESCRIPTION PARAMETER page 5-3.

#### **PARAM. 04 = SPEED BASS**

#### **PARAM. 05 = SPEED TREBLE**

Possible values range between 0 (rotor at standstill) to 99 (high rotation speed).

See DESCRIPTION PARAMETER, page 5-3.

### MECHANICAL PARAMETER

The mechanical parameters control the simulation of the mechanical characteristics of the cabinet.

#### **PARAM. 06 = SLOW-FAST RATIO BASS ROTOR**

#### **PARAM. 07 = SLOW-FAST RATIO TREBLE ROTOR**

This parameter determines the speed ratio between Slow and Fast (Keys 8). The FAST speed remains constant, whilst the value of this parameter can be altered from 0 (SLOW Speed at standstill) to 99 (SLOW SPEED almost FAST).

#### **PARAM. 08 = SPEED-UP BASS-ROTOR**

#### **PARAM. 09 = SPEED-UP TREBLE ROTOR**

This parameter determines the acceleration of the rotation speed when switching from STOP to SLOW or FAST. The value is specified in terms of a time and can be changed from 0 (quick start-up) to 99 (slow start-up).

#### **PARAM. 10 = SPEED-REDUCE BASS-ROTOR**

#### **PARAM. 11 = SPEED-REDUCE TREBLE ROTOR**

This parameter determines the braking properties of the rotor when switching from FAST to SLOW or STOP.

The value is specified in terms of a time and can be changed from 0 (quick braking) to 99 (slow braking).

**PARAM. 12 = ROTATE DIRECTION BASS-ROTOR**  
**PARAM.13 = ROTATE-DIRECTION TREBLE-ROTOR**

This parameter switches the direction from clockwise (right = c) to anti-clockwise (left = ac).

**COLOURED CABINET**

The sound characteristics of different cabinet simulations can be adjusted using parameters 14 - 24.

**PARAM. 14 = FAST-VIBRATO BASS**  
**PARAM. 15 = FAST-VIBRATO TREBLE**

This parameter determines the intensity of the alteration in sound pitch in the "FAST" position. For correct adjustment of this parameter set the unit to "FAST". "FAST" should be adjusted before "SLOW" because both are interdependent. Possible values range between 0 and 15 (see also Options 16, 17),

**PARAM. 16 = SLOW-VIBRATO BASS**  
**PARAM. 17 = SLOW-VIBRATO TREBLE**

This parameter determines the intensity of the alteration in sound pitch in the "SLOW" position. For correct adjustment of this parameter set the unit to "SLOW". "FAST" should have been adjusted before "SLOW" because both are interdependent. Possible values range between 0 and 15 (see also Options 14, 15),

**PARAM. 18 = LIVENESS-BASS**  
**PARAM. 19 = LIVENESS-TREBLE**

This parameter determines the intensity (notch depth) of the modulated comb filters to simulate differently acoustic treated traditional rotating speaker cabinets. Possible values range between +7 and -7 (inverted summation).

**PARAM. 20 = CONTOUR-BASS**  
**PARAM. 21 = CONTOUR-TREBLE**

This parameter modifies the number of the modulated comb filter notches to simulate cabinets with different dimensions. A value of 7 is used for cabinets with quadratic dimensions.

**PARAM. 22 = PANORAMA- BASS**  
**PARAM. 23 = PANORAMA-TREBLE**

This parameter determines the intensity of the left/right modulation, thus changing the stereophone sound image acoustically. Possible settings range between 0 and 7 (= extreme stereo).

**PARAM. 24 = ROOM SIZE**

This parameter is used to simulate a room "around" the cabinet. The value range is 0 to 7 simulating small to large rooms.

**FREQUENCY RESPONSE**

The loudspeakers and high frequency horn drivers used in those days, coupled with the properties and designs of the housings (slits, fabric ...) and high frequency horns gave the organ sound different sound colourations. A variety of cabinets were used to ascertain dominant frequency bands which were then realized as programmable EQ.

**PARAM. 25 = CROSSOVER FREQUENCY**

This parameter determines the sound crossover frequency between bass and treble rotor. The value can be altered from between 0 (see diagram) and 3 (fx = 2 kHz).

Control No. 25 = 0

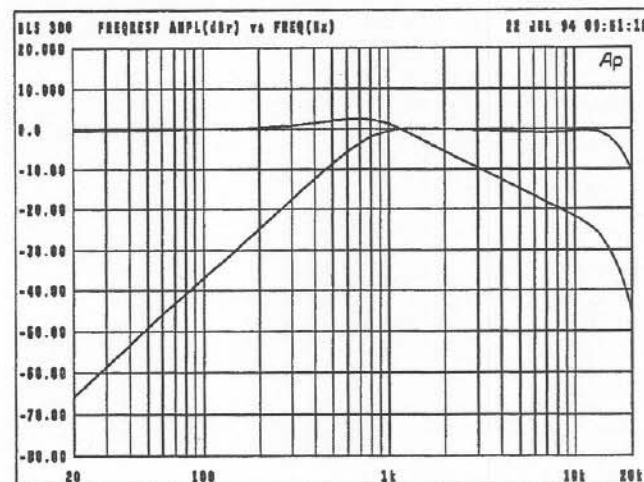

Curve 1 =Bassrotor

Curve 2= Treblerotor

## OPTION

**PARAM. 26 = ACTIVE BASS**  
**PARAM. 27 = ACTIVE TREBLE**

The value can amount to -5..0..+5 (see diagram).

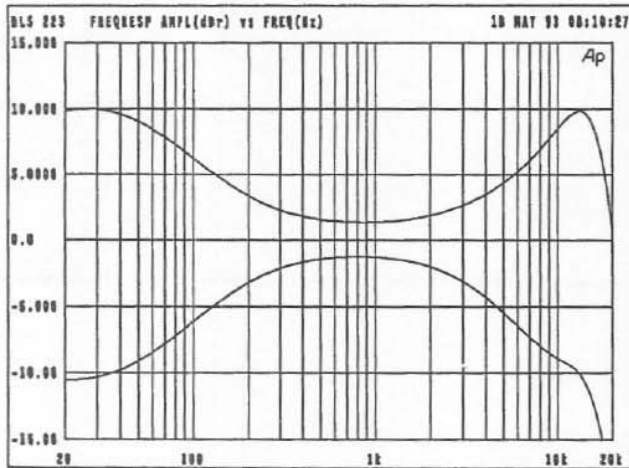

All controls 26-34 to 0 apart from:  
 Curve 1 Bass (No. 26) and Treble (No. 27) = +5  
 Curve 2 Bass (No. 26) and Treble (No. 27) = -5

**PARAM. 28 = EQUALIZER BAND 125 Hz**  
**PARAM. 29 = EQUALIZER BAND 300 Hz**  
**PARAM. 30 = EQUALIZER BAND 800 Hz**  
**PARAM. 31 = EQUALIZER BAND 1500 Hz**

The value can amount to -5..0..+5 (see diagram).

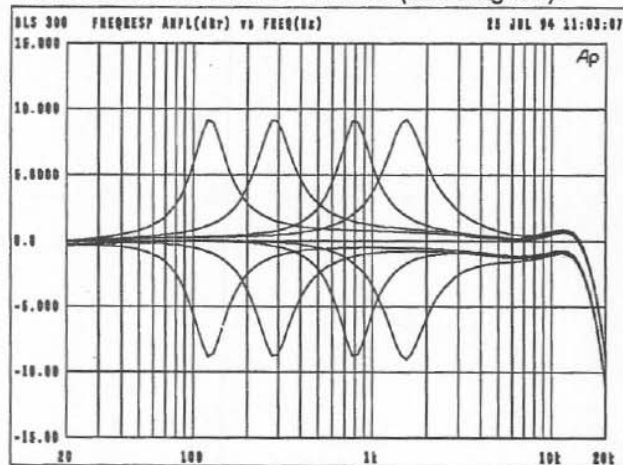

All controls 26-34 to 0 apart from:  
 controls 28, 29, 30 and 31 each to +5 (boost)  
 and -5 (cut).

**PARAM. 32 = PASSIVE BASS**  
**PARAM. 33 = PASSIVE MID**  
**PARAM. 34 = PASSIVE TREBLE**

The value can amount to -5..0 (see diagram).

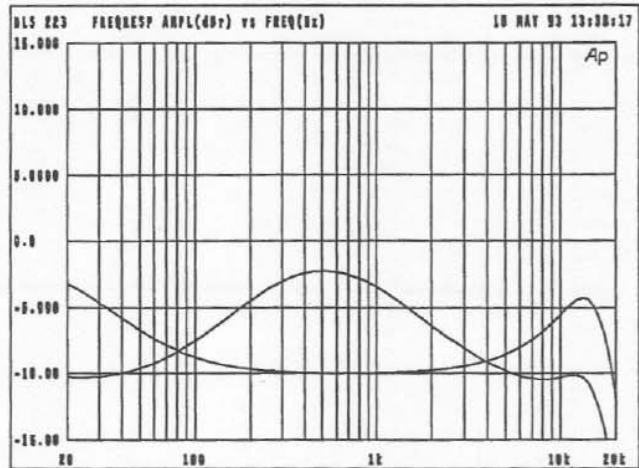

All controls 26-34 to 0 apart from:  
 Curve 1 Bass (No. 32) and Treble (No. 34) = -5  
 Curve 2 Mid (No. 33) = -5

## OUT CONTROL

These parameters are used to adjust the output level of the effect signal, control some of the mechanical parameters and miscellaneous items.

### PARAM. 35 = OUTPUT LEVEL

Volume variations between the individual programs can be balanced. The total output level for the left and right channel is changed between -- (= Off) to -7 and +7).

### PARAM. 36 = STOP DIRECTION

This parameter determines the direction of the rotors in the "STOP" position. The random stop position is maintained with the value 0 (as with most cabinets). The value 1 corrects the stop position to the front side (like CLS 222). Random stop positions can lead to a sound differing after every stop, e.g. too strong reflections (indirect sound) if the rotors come to a halt at the rear side of the cabinet and ROOM is switched on.



**PARAM. 37 = POSITION-CONTROL BASS**  
**PARAM. 38 = POSITION-CONTROL TREBLE**

These two parameters allow a visual check of the position of the rotors in the display (5). The bass rotor is indicated in the tens digit, the treble rotor in the units digit. If the rotors are switched to "STOP", the position can be altered manually via the rotary encoder (9). If "STOP DIRECTION" is switched to 0 (parameter 36), the edited position is maintained.

**PARAMETER 39 = SPEEDO-CONTROL-BASS**  
**PARAMETER 40 = SPEEDO-CONTROL-TREBLE**

These two parameters allow a visual check of the speed of the rotors in the display (5). Values displayed can range between 0 (standstill) to 99.

**PARAM. 41 = LEVEL-PEAKHOLD-TIME**

This parameter sets the hold time of the Peak LED in the input level meter (3). Settings are possible between 0 and 42 (1 step = 0.1 sec.). "STORE" saves this hold time (global parameter).

**PARAM. 42 = RECEIVE - REMOTE - SYSEX**

This switch activates the remote control feature via MIDI SYSEX data (=1). The value 0 blocks the reception of remote control data.



# OPTION

## LIST OF OPTIONS

<b>GENERAL</b>	<p>FUNCTION 00 = ADDITIONAL FACTORY PRESETS          PARAMETER 01 = DISTORTION          PARAMETER 02 = ROOM          PARAMETER 03 = ROTOR-BALANCE          PARAMETER 04 = SPEED-BASS          PARAMETER 05 = SPEED-TREBLE</p>
<b>MECHANICAL</b>	<p>PARAMETER 06 = SLOW-FAST RATIO BASS          PARAMETER 07 = SLOW-FAST RATIO TREBLE          PARAMETER 08 = SPEED-UP BASS          PARAMETER 09 = SPEED-UP TREBLE          PARAMETER 10 = SPEED-REDUCE BASS          PARAMETER 11 = SPEED-REDUCE TREBLE          PARAMETER 12 = ROTATE-DIRECTION BASS          PARAMETER 13 = ROTATE-DIRECTION TREBLE</p>
<b>COLOURED CABINET</b>	<p>PARAMETER 14 = FAST-VIBRATO-BASS          PARAMETER 15 = FAST-VIBRATO-TREBLE          PARAMETER 16 = SLOW-VIBRATO-BASS          PARAMETER 17 = SLOW-VIBRATO-TREBLE          PARAMETER 18 = LIVENESS-BASS          PARAMETER 19 = LIVENESS-TREBLE          PARAMETER 20 = CONTOUR BASS          PARAMETER 21 = CONTOUR TREBLE          PARAMETER 22 = PANORAMA BASS          PARAMETER 23 = PANORAMA TREBLE          PARAMETER 24 = ROOM-SIZE</p>
<b>FREQUENCY RESPONSE</b>	<p>PARAMETER 25 = CROSSOVER-FREQUENCY          PARAMETER 26 = ACTIVE-EQ BASS 40 HZ          PARAMETER 27 = ACTIVE-EQ TREBLE 12 kHz          PARAMETER 28 = ACTIVE-EQ BAND 125Hz          PARAMETER 29 = ACTIVE-EQ BAND 300Hz          PARAMETER 30 = ACTIVE-EQ BAND 800Hz          PARAMETER 31 = ACTIVE-EQ BAND 1.5 kHz          PARAMETER 32 = PASSIVE-EQ BASS          PARAMETER 33 = PASSIVE-EQ MID          PARAMETER 34 = PASSIVE-EQ TREBLE</p>
<b>OUT- CONTROL</b>	<p>PARAMETER 35 = OUTPUT-LEVEL          PARAMETER 36 = STOP-DIRECTION          PARAMETER 37 = POSITION-CONTROL-BASS          PARAMETER 38 = POSITION-CONTROL-TREBLE          PARAMETER 39 = SPEED-CONTROL-BASS          PARAMETER 40 = SPEED-CONTROL-TREBLE          PARAMETER 41 = PEAKHOLD-TIME          PARAMETER 42 = SYSEX-REMOTE-CONTROL</p>

## LIST OF FACTORY PRESETS (FUNCTION 00)

PRESET 01 = "Classic Rotor"	PRESET 9 = "Honky Tonk Piano"
PRESET 02 = "Ambience Cabinet"	PRESET 10 = "Jazz Organ"
PRESET 03 = "Rock Organ"	PRESET 11 = "Sweet Guitar"
PRESET 04 = "CLS 222"	PRESET 12 = "Walking Bass"
PRESET 05 = "Spacious CLS"	PRESET 13 = "Happy Music"
PRESET 06 = "Church Organ"	
PRESET 07 = "Damaged Cabinet"	
PRESET 08 = "Singing Sax"	

## 7. MIDI

MIDI connection is possible via the MIDI sockets IN/OUT/THRU (15). The MIDI functions within the Fx 70 allow the appliance to be controlled externally. The diverse and flexible possibilities mean that all functions can be controlled from a MIDI-compatible unit (e.g. computer, sequencer, keyboard...). E.g.

- Switching over programmes
- Changing certain parameters
- Switching the effect signal on or off
- Switching over the rotor speed
- All control elements (remote control of the Fx 70)

and many, many more.....

Should you still not have had any experience with MIDI we recommend that you first gather information on MIDI standards and interfaces (e.g. MIDI books, computer and music journals etc.) There is also a brief explanation in the annex, chapter 9).

### 7.1 BASIC SETTINGS

Pressing the MIDI key briefly puts the MIDI channel or mode on the display (5). Alterations can be made via the rotary control (9) and take effect immediately.

The following settings are possible:

"-" no MIDI evaluation (MIDI OFF)

"on" MIDI reception in Omni Mode (all channels are received)

"01" - "16" reception on MIDI channel 1 - 16

The selected MIDI channel setting can be saved in the memory via the button "STORE" (see 5.4). If no other parameter is to be altered, perform the following sequence.

Push a program key (e.g. 1), the STORE key and then the same program key again.

This will store the program (e.g. 1), into the same memory place and the new MIDI channel setting is saved a global MIDI allocation (see 4.1, 5.4).

If the STORE key is pressed for approx. 3 sec., the MIDI channel is set to OMNI mode (see 5.4).

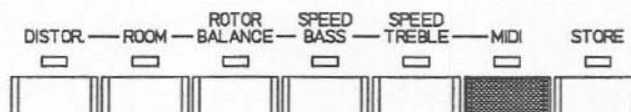

### 7.2 MIDI INPUT CONTROL

If there are data on the MIDI INPUT (15) which comply with MIDI channel or mode selected in the Fx 70, the decimal point of the display (5) lights up briefly.

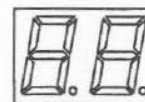

VALUE

### 7.3 REMOTE CONTROL VIA MIDI

All Fx 70 parameters and keys can be remote controlled in real time via the MIDI INPUT (15). This necessitates a MIDI-compatible device as a MIDI transmitter.

To control the Fx 70 via a MIDI Controller, this allocation takes place in LEARN MODE.

All MIDI CONTROLLERS or MIDI functions (note on/off...) can be used to control the Fx 70.

# MIDI

## 7.4 MIDI LEARN MODE

You can switch to the LEARN MODE of the Fx 70 by pressing the required function key together with the MIDI key.

Readiness to learn is indicated via common flashing of the MIDI LED and the LED of the key to be "learnt".

Possible key functions include EFF.ON, PROG1, PROG2, PROG3, STOP, SLOW or FAST.

Possible control functions include DISTOR., ROOM, ROTOR-BALANCE, SPEED-BASS, SPEED-TREBLE.

If a MIDI event is received and accepted on the MIDI input, (the decimal point lights up as described under 7.2), flashing ceases and the key which has been learnt is then carried out for the first time.

The function which has been learnt applies to all 3 programmes (global allocation) and is saved, i.e. is maintained even after the Fx 70 has been switched off and is available again once the Fx 70 has been switched on.

Several ("all") switches and parameters of the Fx 70 can be learnt in this way. Allocations of various control functions to the same MIDI controller are also possible.

The learn mode can be cancelled by pressing any key.

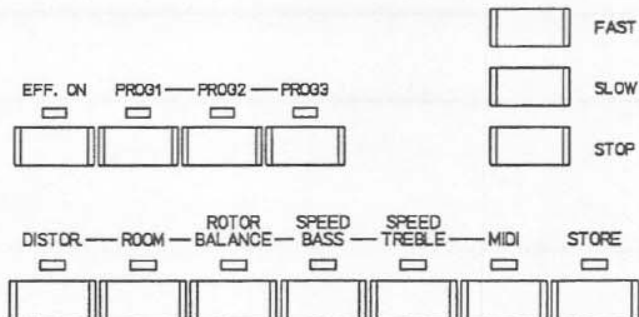

## 7.5 DELETING MIDI ALLOCATIONS

Pressing the MIDI key for 3 seconds deletes "all" MIDI allocations learnt. Deletion is indicated by the Status LED's fading briefly.

A single MIDI Event which has been learnt can be deleted by pressing the MIDI and the respective function key together for 3 seconds. The MIDI LED and the status LED to be deleted flash on and off together for the duration of the 3 seconds. The event is subsequently deleted, this being indicated when the flashing ceases.

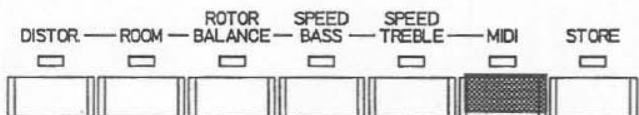

## 7.6 MIDI-LEARN EXAMPLE

A description of how to control the rotor speed serves as an example to show the possibilities to control the Fx 70 via MIDI.

There are 3 different solutions depending on the type of MIDI transmitter (keyboard) in question.

- 1 Your MIDI keyboard has three free switches (MIDI switch) which can be used to control the Fx 70 functions "STOP", "SLOW" and "FAST". The three keys are learnt successively in MIDI LEARN MODE.
- 2 Your MIDI keyboard has a free controller (e.g Modulation Wheel) which should be used to control the Fx 70 functions "STOP", "SLOW" and "FAST". The controller on the keyboard is turned down as far as possible and then the Fx 70 is switched to the MIDI LEARN MODE for "STOP". Moving the controller briefly is enough to learn the "STOP" key. The controller is moved into a central position, the Fx 70 is put into MIDI LEARN MODE for the "SLOW" key and the controller is moved briefly. The modulation wheel is moved up as far as possible, the Fx 70 is put into MIDI LEARN MODE for "FAST" and the wheel is moved briefly. The controller modulation wheel can now be used to switch over the Fx 70 functions "STOP", "SLOW" and "FAST". The controller range can be divided up as follows: lower third "STOP", middle third "SLOW", upper third "FAST". The ranges (MIDI RANGE) can be selected as required and are learnt in LEARN MODE by the current position of the controller.
- 3 Your MIDI keyboard has a free controller (e.g. modulation wheel) which should be used to control the Fx 70 function "SPEED BASS", "SPEED TREBLE". The Fx 70 is switched to MIDI LEARN MODE for "SPEED BASS". (MIDI and SPEED BASS LED's flash on and off). The controller is moved briefly (flashing goes off) and has thus been learnt. The same procedure is followed for "SPEED TREBLE". The "FAST" key on the Fx 70 is pressed, thus enabling the user to adjust the speed of the two rotors with the modulation wheel. The range (MIDI RANGE) is steplessly adjustable between standstill and maximum speed.

### Note:

All these functions are stored automatically as global MIDI allocations (without STORE key). That means that they are applicable for all three programmes and are also maintained after the Fx 70 has been switched off.

## MIDI ARRANGEMENTS

The Fx 70 reacts to so-called MIDI Events.

Reception of a MIDI Event corresponds to a key being pressed on the Fx 70 (see key functions (7.4)), provided that this has been learnt before. All functions possible via MIDI and CONTROLLER serve as MIDI Events.

Once a Fx 70 parameter has been learnt (see control functions (7.4)), this entire control range (100%) is allocated to the entire valuation range (100%) of the MIDI CONTROLLER.

# MIDI

## 7.7 MIDI System Exclusive Implementation

This chapter contains information to enable programmers to write software for the Fx 70. It contains definitions of all commands necessary to transmit or receive data via the MIDI interface.

Data transfer is only possible by MIDI when a MIDI channel has been set (OMNI, 1 - 16). With a MIDI reception channel - - there is no communication via the MIDI interface (see Chapter 7.1).

MIDI system exclusive Electro Voice Fx 70  
MIDI SYSEX Fx 70 Version 2.0.

### **SYSEX-FUNCTION "IDENTITY REQUEST":** (recognized)

F0h	240	message "system-exclusive"
7Eh	126	sysex-id "universal non-realtime"
xxh	x	MIDI-channel (00h..0Fh for channel 1..16, 7Fh for all channels)
06h	6	id "general information"
01h	1	function-code "identity request"
F7h	247	message "end of system-exclusive"

This command instructs the Fx 70 to report with its identity code.

### **SYSEX-FUNCTION "IDENTITY REPLY":** (transmitted)

F0h	240	message "system-exclusive"
7Eh	126	sysex-id "universal non-realtime"
xxh	x	MIDI-channel (00h..0Fh for channel 1..16, 7Fh for all channels)
06h	6	id "general information"
02h	2	function-code "identity reply"
30h	48	manufacturer-id no.48
1Eh 00h	30 0	device-family-code "Fx 70" no.30
00h 00h	0 0	device-family-member
yyh.. yyh	y..y	4 Byte revision-code in ascii (i.e. "1.0 ")
F7h	247	message "end of system-exclusive"

The Fx 70 transmits this identity code in answer to an identity request.

### **SYSEX-FUNCTION "REQUEST CURRENT PARAMETERS":** (recognized)

F0h	240	message "system-exclusive"
30h	48	sysex-id
xxh	x	MIDI-channel (00h..0Fh for channel 1..16, 7Fh for all channels)
1Eh	30	device-id "Fx 70"
10h	16	function-code "request current parameters"
yyh	y	number of first parameter requested
zzh	z	number of last parameter requested
F7h	247	message "end of system-exclusive"

This command instructs the Fx 70 to transfer one or more parameters to the program setting which can currently be heard. In answer the Fx 70 transmits a SYSEX record in format "Parameter Adjust". See also the following list of "Parameter Adjust Numbers".



**SYSEX-FUNCTION "PARAMETER ADJUST":** *(transmitted and recognized)*

F0h	240	message "system-exclusive"
30h	48	sysex-id
xxh	x	MIDI-channel (00h..0Fh for channel 1..16, 7Fh for all channels)
1Eh	30	device-id "Fx 70"
30h	48	function-code "parameter adjust"
yyh	y	number of first parameter to adjust
vvh	v	value of first parameter to adjust
[ vvh .. vvh ]	[ v...v ]	value(s) of next following parameter(s) to adjust
F7h	247	message "end of system-exclusive"

This command is used to edit one or more parameters in the current setting. Each parameter is represented by one MIDI data byte. These edits are active immediately. User programs are not altered!

See the following list of "Parameter Adjust numbers".  
[... ] optional

**SYSEX-FUNCTION "REQUEST CURRENT PROGRAM DUMP":** *(recognized)*

F0h	240	message "system-exclusive"
30h	48	sysex-id
xxh	x	MIDI-channel (00h..0Fh for channel 1..16, 7Fh for all channels)
1Eh	30	device-id "Fx 70"
11h	17	function-code "request dump current program"
F7h	247	message "end of system-exclusive"

This command instructs the Fx 70 to transmit the current program setting as a complete data record. In answer the Fx 70 transmits a Sysex record in the format "Current Program Dump".

See also the following list "Program Structure".

**SYSEX-FUNCTION "CURRENT PROGRAM DUMP":** *(transmitted and recognized)*

F0h	240	message "system-exclusive"
30h	48	sysex-id
xxh	x	MIDI-channel (00h..0Fh for channel 1..16, 7Fh for all channels)
1Eh	30	device-id "Fx 70"
31h	49	function-code "dump current program"
yyh .. yyh	y...y	32 bytes midi8/7-code (program-structure)
ssh	s	checksum of midi8/7-code
F7h	247	message "end of system-exclusive"

The data record supplied with this command is adopted completely as the current program. User programs are not altered!

See also the following list "Program Structure".

**SYSEX-FUNCTION "REQUEST SINGLE PROGRAM DUMP":** (recognized)

F0h	240	message "system-exclusive"
30h	48	sysex-id
xxh	x	MIDI-channel (00h..0Fh for channel 1..16, 7Fh for all channels)
1Eh	30	device-id "Fx 70"
14h	20	function-code "request dump single program"
yyh	y	source-number of requested program (1..3)
zzh	z	destination-number of requested program (1..3)
F7h	247	message "end of system-exclusive"

This command instructs the Fx 70 to transfer a single user program setting as a complete data record. In answer the Fx 70 transmits a Sysex record in the format "Single Program Dump".

See also the following list "Program Structure".

**SYSEX-FUNCTION "SINGLE PROGRAM DUMP":** (transmitted and recognized)

F0h	240	message "system-exclusive"
30h	48	sysex-id
xxh	x	MIDI-channel (00h..0Fh for channel 1..16, 7Fh for all channels)
1Eh	30	device-id "Fx 70"
34h	52	function-code "dump single program"
zzh	z	destination-number of program (1..3)
yyh .. yyh	y...y	32 bytes midi8/7-code
ssh	s	checksum of midi8/7-code
F7h	247	message "end of system-exclusive"

The data record supplied with this command is adopted entirely as a single user program. The current program is not altered!

See also the following list "Program Structure".

**SYSEX-FUNCTION "REQUEST ALL PROGRAMS DUMP":** (recognized)

F0h	240	message "system-exclusive"
30h	48	sysex-id
xxh	x	MIDI-channel (00h..0Fh for channel 1..16, 7Fh for all channels)
1Eh	30	device-id "Fx 70"
12h	18	function-code "request dump all programs"
F7h	247	message "end of system-exclusive"

This command instructs the Fx 70 to transfer all three user program settings as a complete data record. In answer the Fx 70 transmits a Sysex record in the format "All Programs Dump".

See also the following list "Program Structure".

**SYSEX-FUNCTION "ALL PROGRAMS DUMP":** (transmitted and recognized)

F0h	240	message "system-exclusive"
30h	48	sysex-id
xxh	x	MIDI-channel (00h..0Fh for channel 1..16, 7Fh for all channels)
1Eh	30	device-id "Fx 70"
32h	50	function-code "dump all programs"
yyh .. yyh	y...y	96 bytes midi8/7-code
ssh	s	checksum of midi8/7-code
F7h	247	message "end of system-exclusive"

The data record supplied with this command is adopted entirely in all three user programs.  
The current program is not altered!

See also the following list "Program Structure".

**SYSEX-FUNCTION "REQUEST POWER-UP DATA DUMP":** (recognized)

F0h	240	message "system-exclusive"
30h	48	sysex-id
xxh	x	MIDI-channel (00h..0Fh for channel 1..16, 7Fh for all channels)
1Eh	30	device-id "Fx 70"
13h	19	function-code "request dump power-up data"
F7h	247	message "end of system-exclusive"

This command instructs the Fx 70 to transfer the switch-on status (MIDI Channel, Option parameter number, program number). In answer the Fx 70 transmits a Sysex record in the format "Power-up Data Dump".

**SYSEX-FUNCTION "POWER-UP DATA DUMP":** (transmitted and recognized)

F0h	240	message "system-exclusive"
30h	48	sysex-id
xxh	x	MIDI-channel (00h..0Fh for channel 1..16, 7Fh for all channels)
1Eh	30	device-id "Fx 70"
33h	51	function-code "dump power-up data"
yyh .. yyh	y...y	7 bytes midi8/7-code
ssh	s	checksum of midi8/7-code
F7h	247	message "end of system-exclusive"

The data record supplied with this command is adopted as future Power-up status.

**SYSEX-FUNCTION "REQUEST MIDI-EVENT LIST DUMP":** (recognized)

F0h	240	message "system-exclusive"
30h	48	sysex-id
xxh	x	MIDI-channel (00h..0Fh for channel 1..16, 7Fh for all channels)
1Eh	30	device-id "Fx 70"
16h	22	function-code "request dump MIDI-eventlist"
F7h	247	message "end of system-exclusive"

This command instructs the Fx 70 to transfer the learnt MIDI event list. In answer the Fx 70 transmits a Sysex record in the format "MIDI Event List Dump".

See also the following "Event List".

**SYSEX-FUNCTION "MIDI-EVENT LIST DUMP":** (transmitted and recognized)

F0h	240	message "system-exclusive"
30h	48	sysex-id
xxh	x	MIDI-channel (00h..0Fh for channel 1..16, 7Fh for all channels)
1Eh	30	device-id "Fx 70"
36h	54	function-code "dump MIDI-eventlist"
yyh .. yyh	y...y	28 bytes midi8/7-code
ssh	s	checksum of midi8/7-code
F7h	247	message "end of system-exclusive"

The data record supplied with this command is adopted as a MIDI Event list. This new Event list takes effect immediately and previous MIDI Event data are overwritten.

See also the following "Event List".

**SYSEX-FUNCTION "REQUEST STORE":** (recognized)

F0h	240	message "system-exclusive"
30h	48	sysex-id
xxh	x	MIDI-channel (00h..0Fh for channel 1..16, 7Fh for all channels)
1Eh	30	device-id "Fx 70"
15h	21	function-code "request store"
yyh	y	destination-number of program (1..3)
F7h	247	message "end of system-exclusive"

This command instructs the Fx 70 to save the current audible program as a user program. Once the program has been saved the Fx 70 transmits a Sysex record in the format "Requested Store Processed".

**SYSEX-FUNCTION "REQUESTED STORE PROCESSED":** (transmitted)

F0h	240	message "system-exclusive"
30h	48	sysex-id
xxh	x	MIDI-channel (00h..0Fh for channel 1..16, 7Fh for all channels)
1Eh	30	device-id "Fx 70"
35h	53	function-code "requested store processed"
F7h	247	message "end of system-exclusive"

Is transferred once the saving procedure has been carried out successfully via "Request Store".

**SYSEX-FUNCTION "CALL PROGRAMM":** (recognized)

F0h	240	message "system-exclusive"
30h	48	sysex-id
xxh	x	MIDI-channel (00h..0Fh for channel 1..16, 7Fh for all channels)
1Eh	30	device-id "Fx 70"
17h	23	function-code "call program"
yyh	y	number of program to call (1..3 for user, 4..n for factory)
F7h	247	message "end of system-exclusive"

This command instructs the Fx 70 to load a user or factory program as current audible program.

**SYSEX-FUNCTION "REMOTE KEYPRESS":** (transmitted and recognized)

F0h	240	message "system-exclusive"
30h	48	sysex-id
xxh	x	MIDI-channel (00h..0Fh for channel 1..16, 7Fh for all channels)
1Eh	0	device-id "Fx 70"
77h	119	function-code "remote keypress"
yyh	y	number of first key to press (see list below)
[ yyh .. yyh ]	[ y...y ]	value(s) of next following key(s) to press
F7h	247	message "end of system-exclusive"

This command is used for remote control of operation elements (keyboard, encoder).

[... ] optional

**SYSEX-FUNCTION "REMOTE ENCODER":** (transmitted and recognized)

F0h	240	message "system-exclusive"
30h	48	sysex-id
xxh	x	MIDI-channel (00h..0Fh for channel 1..16, 7Fh for all channels)
1Eh	30	device-id "Fx 70"
78h	120	function-code "remote encoder"
yyh	y	value of first encoder-turn (7bit two's-complement)
[ yyh .. yyh ]	[ y...y ]	value(s) of next following encoder-turn(s)
F7h	247	message "end of system-exclusive"

This command is used for remote control of the encoder

[... ] optional

**SYSEX-FUNCTION "REQUEST COMPLETE EEPROM DUMP":** (recognized)

F0h	240	message "system-exclusive"
30h	48	sysex-id
xxh	x	MIDI-channel (00h..0Fh for channel 1..16, 7Fh for all channels)
1Eh	30	device-id "Fx 70"
7Ah	122	function-code "request dump complete eeprom"
F7h	247	message "end of system-exclusive"

This command instructs the Fx 70 to dump the complete memory content. In answer the Fx 70 transmits a Sysex record in the format "Complete Eeprom Dump".

**SYSEX-FUNCTION "COMPLETE EEPROM DUMP":** (transmitted and recognized)

F0h	240	message "system-exclusive"
30h	48	sysex-id
xxh	x	MIDI-channel (00h..0Fh for channel 1..16, 7Fh for all channels)
1Eh	30	device-id "Fx 70"
79h	121	function-code "dump complete eeprom"
yyh .. yyh	y...y	147 bytes midi8/7-code
ssh	s	checksum of midi8/7-code
F7h	247	message "end of system-exclusive"

The data record supplied with this command is adopted as memory content. User programs, MIDI event list und Power-on status are thus overwritten. The current audible program is not altered!



## PARAMETER-ADJUST-NUMBERS

no. hex	Parameter		MIDI-range		Display option-mode	
	no. dec	name	hex	dec	no.	range
00h	0	distortion	00h...0Fh	0...15	01	0...15
01h	1	room	00h...7Fh	0...127	02	0...15
02h	2	rotor-balance	40h..00h..3Fh	-64..0..+63	03	-9..0..9
03h	3	speed bass	00h...7Fh	0...127	04	0...99
04h	4	speed treble	00h...7Fh	0...127	05	0...99
05h	5	slow/fast-ratio bass	00h...7Fh	0...127	06	0...99
06h	6	slow/fast-ratio treble	00h...7Fh	0...127	07	0...99
07h	7	speed-up bass	00h...7Fh	0...127	08	0...99
08h	8	speed-up treble	00h...7Fh	0...127	09	0...99
09h	9	speed-reduce bass	00h...7Fh	0...127	10	0...99
0Ah	10	speed-reduce treble	00h...7Fh	0...127	11	0...99
0Bh	11	rotate-direction bass	00h...01h	0...1	12	c / ac
0Ch	12	rotate-direction treble	00h...01h	0...1	13	c / ac
0Dh	13	fast-vibrato bass	00h...0Fh	0...15	14	0...15
0Eh	14	fast-vibrato treble	00h...0Fh	0...15	15	0...15
0Fh	15	slow-vibrato bass	00h...0Fh	0...15	16	0...15
10h	16	slow-vibrato treble	00h...0Fh	0...15	17	0...15
11h	17	liveness bass	79h...00h...07h	-7...0...+7	18	-7...0..7
12h	18	liveness treble	79h...00h...07h	-7...0...+7	19	-7...0..7
13h	19	contour bass	00h...63h	0...99	20	0...99
14h	20	contour treble	00h...63h	0...99	21	0...99
15h	21	panorama bass	00h...07h	0...7	22	0...7
16h	22	panorama treble	00h...07h	0...7	23	0...7
17h	23	room-size	00h...0Fh	0...15	24	0...7
18h	24	crossover-frequency	00h...03h	0...3	25	0...3
19h	25	active-eq bass 40Hz	7Bh..00h..05h	-5...0...+5	26	-5..0..5
1Ah	26	active-eq treble 12kHz	7Bh..00h..05h	-5...0...+5	27	-5..0..5
1Bh	27	active-eq band 125Hz	7Bh..00h..05h	-5...0...+5	28	-5..0..5
1Ch	28	active-eq band 300Hz	7Bh..00h..05h	-5...0...+5	29	-5..0..5
1Dh	29	active-eq band 800Hz	7Bh..00h..05h	-5...0...+5	30	-5..0..5
1Eh	30	active-eq band 1,5kHz	7Bh..00h..05h	-5...0...+5	31	-5..0..5
1Fh	31	passive-eq bass	7Bh..00h	-5...0	32	-5..0
20h	32	passive-eq mid	7Bh..00h	-5...0	33	-5..0
21h	33	passive-eq treble	7Bh..00h	-5...0	34	-5..0
22h	34	output-level	78h..00h..07h	-8...0...+7	35	--..0..7
23h	35	stop-direction	00h...01h	0...1	36	0 / 1
24h	36	stop/start	00h...01h	0...1		
25h	37	slow/fast	00h...01h	0...1		
26h	38	effect off/on	00h...01h	0...1		

You will find the meanings of the parameters in chapter "Option".

h stands for hexadecimal values

**EVENTLIST (MIDI-EVENTLIST-DUMP)***the eventlist consists of 12 words with 16bit each*

event 0	effect on
event 1	prog1
event 2	prog2
event 3	prog3
event 4	stop
event 5	slow
event 6	fast
event 7	distortion
event 8	room
event 9	rotor-balance
event 10	speed bass
event 11	speed treble

each 16bit-word looks as follows:

```
1111 11
5432 1098 7654 3210
xxxx xxxx yyyy yyz
```

xx = learned MIDI-event    yy = learned data

00h	note-off	notenumber
01h	release	value
02h	note-on	notenumber
03h	velocity	value
04h	poly-pressure	notenumber
05h	poly-pressure	value

06h	controller 0	value
07h	controller 1	value
:	:	:
7Eh	controller 120	value
7Fh	program-change	value
80h	channel-pressure	value
81h	pitch-wheel	value
FFh	no event learned	7Fh

z = marks exact-trigger-event or besthit-range-event

## PROGRAM-STRUCTURE (PROGRAM-DUMP)

each program consists of a 28 bytes parameter-set as shown:

byte 0	bit 7...0	system-internal (should not be changed)
byte 1	bit 7...4	active-eq bass 40Hz
byte 1	bit 3...0	system-internal (should not be changed)
byte 2	bit 7...4	active-eq band 300Hz
byte 2	bit 3...0	system-internal (should not be changed)
byte 3	bit 7...4	active-eq band 800Hz
byte 3	bit 3...0	system-internal (should not be changed)
byte 4	bit 7...4	active-eq band 125Hz
byte 4	bit 3...0	passive-eq bass
byte 5	bit 7...4	active-eq band 1,5kHz
byte 5	bit 3...0	passive-eq mid
byte 6	bit 7...4	active-eq treble 12kHz
byte 6	bit 3...0	passive-eq treble
byte 7	bit 7	stop-direction
byte 7	bit 6...0	system-internal (should not be changed)
byte 8	bit 7...0	speed treble
byte 9	bit 7...0	speed bass
byte 10	bit 7...0	slow/fast-ratio treble
byte 11	bit 7...0	slow/fast-ratio bass
byte 12	bit 7...0	speed-up treble
byte 13	bit 7...0	speed-up bass
byte 14	bit 7...0	speed-reduce treble
byte 15	bit 7...0	speed-reduce bass
byte 16	bit 7...0	rotor-balance
byte 17	bit 7...4	crossover-frequency
byte 17	bit 3...0	output-level
byte 18	bit 7...4	distortion
byte 18	bit 3...0	room-size
byte 19	bit 7...0	room
byte 20	bit 7...4	slow-vibrato treble
byte 20	bit 3...0	fast-vibrato treble
byte 21	bit 7...4	slow-vibrato bass
byte 21	bit 3...0	fast-vibrato bass
byte 22	bit 7...0	contour treble
byte 23	bit 7...0	contour bass
byte 24	bit 7...4	liveness treble
byte 24	bit 3...0	liveness bass
byte 25	bit 7	rotate-direction treble
byte 25	bit 6...4	panorama treble
byte 25	bit 3	rotate-direction bass
byte 25	bit 2...0	panorama bass
byte 26	bit 7...0	system-internal (should not be changed)
byte 27	bit 7...0	system-internal (should not be changed)

## KEYBOARD-NUMBERS (REMOTE-KEYPRESS)

nr.	key		
hex	dec		
01h	1	effect-on	
02h	2	prog1	
03h	3	prog2	
04h	4	prog3	
05h	5	distortion	
06h	6	room	
07h	7	rotor-balance	
08h	8	speed bass	
09h	9	speed treble	
0Ah	10	midi	
0Bh	11	store	
0Ch	12	stop	
0Dh	13	slow	
0Eh	14	fast	
0Fh	15	encoder-key	
10h	16	slow/fast footswitch	
11h	17	start/stop footswitch	
12h	18	midi + effect-on	(= learn event)
13h	19	midi + prog1	(= learn event)
14h	20	midi + prog2	(= learn event)
15h	21	midi + prog3	(= learn event)
16h	22	midi + stop	(= learn event)
17h	23	midi + slow	(= learn event)
18h	24	midi + fast	(= learn event)
19h	25	midi + distortion	(= learn event)
1Ah	26	midi + room	(= learn event)
1Bh	27	midi + rotor-balance	(= learn event)
1Ch	28	midi + speed bass	(= learn event)
1Dh	29	midi + speed treble	(= learn event)
1Eh	30	longpress midi + effect-on	(= forget event)
1Fh	31	longpress midi + prog1	(= forget event)
20h	32	longpress midi + prog2	(= forget event)
21h	33	longpress midi + prog3	(= forget event)
22h	34	longpress midi + stop	(= forget event)
23h	35	longpress midi + slow	(= forget event)
24h	36	longpress midi + fast	(= forget event)
25h	37	longpress midi + distortion	(= forget event)
26h	38	longpress midi + room	(= forget event)
27h	39	longpress midi + rotor-balance	(= forget event)
28h	40	longpress midi + speed bass	(= forget event)
29h	41	longpress midi + speed treble	(= forget event)
2Ah	42	longpress midi	(= forget all events)
2Bh	43	longpress speed bass + speed treble	(= option-mode)
2Ch	44	longpress store	(= restore all presets)
2Dh	45	longpress prog1	(= restore preset)
2Eh	46	longpress prog2	(= restore preset)
2Fh	47	longpress prog3	(= restore preset)
30h	48	longpress distortion + speed treble	(= service)
32h	50	encoder one step up	
33h	51	encoder one step down	
34h	52	service-key index	
35h	53	service-key value	

### MIDI8/7-CODE

a transfer of seven 8bit-databytes via MIDI-sysex affects in transmission of eight MIDI-data-bytes (with MSB=0) according to the following pattern:

AAAAaaaa BBBBbbbb CCCccccc DDDDdddd EEEEeeee FFFFffff GGGGgggg

gets to

0GFEDCBA 0AAAAaaa 0BBBBbbb 0CCCcccc 0DDDdddd 0EEEeeee 0FFFffff 0GGGgggg

( first ----- last transmitted )

The checksum transmitted finally is the 2's-complement of the 7bit-sum of all the MIDI8/7-data before.



## 8. REMOTE CONTROL

### 8.1 REMOTE CONNECTIONS:

Different Fx 70 functions can be remote controlled via foot switch.

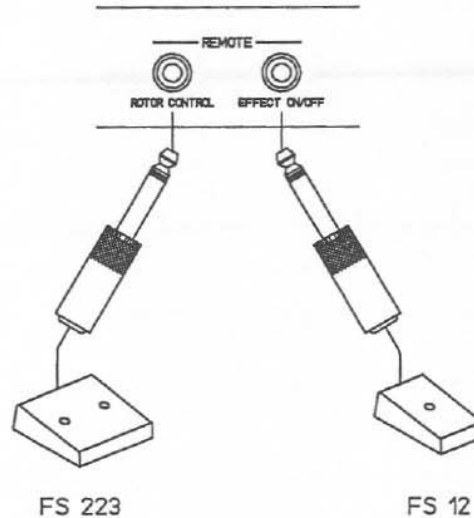

**ROTOR CONTROL -** When the double foot switch FS 223 is connected to this socket, both treble and bass rotors can be switched together. The functions ROTOR-ON/OFF and FAST/SLOW are thus possible. The status is indicated by the 3 LED's on the front panel.

**EFFECT ON/OFF -** When the foot switch FS 12 is connected to this socket it is possible to switch from original to effect signal (see front panel key (4.1)). The status is indicated by the Status LED on the front panel.

**Note:**

Other foot switches can be used apart from the FS 223 and FS 12 specified here, the only precondition being that it must be a momentary switch rather than a latching switch and the contact must be closed on activation!

## 9. APPENDIX

Operation of the Fx 70 was designed in such a way that all functions and parameters are quickly and easily accessible. The idea was based on various organ cabinets and the Simulator CLS 222.

For our simulation purposes we did, however, eliminate all the various noises connected with these "ancient dinosaurs!"

The Fx 70 was equipped with MIDI control possibilities and additional programs to utilize the unique rotor effect with more modern instruments (organs, keyboards, computers ...) more efficiently. Identifying all the parameters hidden under Options and Sysex should really be a delight for sound sleuths!

As younger contemporaries are only familiar with these cabinets from records and CD's we have included a brief description of the mechanics and sound properties thereof.



In the Sixties to the mid-Seventies, the heyday of cabinets, there was an enormous variety of types and manufacturers. The pictures above correspond with the most common forms produced. The dimensions measured approx. 80 x 60 cm, the height between 100 and 150 cm. The cabinets weighed anything between 40 and 100 kg.

A frequency crossover was used to supply the two loudspeakers, the bass rotor below and the treble rotor above with organ signals via power amplifiers integrated in the cabinets. The rotors were partially located in two separate housings to facilitate transportation.

Sound guide drums (low frequency) and horns were mounted in front of the loudspeaker membranes or compression drivers. These were pivotable so that the sound could be reflected in all directions, driven by two (sometimes four) motors. These rotating sound sources led to the unmistakable sound of the rotor cabinets.

Important contributory physical effects included: Doppler effect (pitch jumps) when passing the listener, panorama effect via direct and lateral sound emission and room effect due to the creation of a lot of reflections when the rotors were facing towards the rear. Interference sounds resulted from the slightly varying speeds of the two rotors. This effect is especially marked when the speed is switched over from stop - slow - fast, as the variety of varying differences crop up due to the differing rotor masses.

The materials used for housing, loudspeakers and rotors, along with the finish of the materials, play an important role in the characteristic sound effects produced. Rotors were made of wood, cardboard, polystyrene, aluminium and plastic.

All the above-mentioned effects and peculiarities were examined and taken into consideration for simulation purposes involving the Fx 70.

## 9.1 WHAT IS MIDI?

As the name already says MIDI (Musical Instrument Digital Interface) is a standardized data interface for musical instruments and devices.

In the normal MIDI standard, MIDI controllers, MIDI switches, MIDI Note Numbers etc. are determined. As in computer technology, all Midi Events are given a certain address (byte sequence) which is recognized by all functional MIDI interfaces alike. MIDI means a language with which devices made by different manufacturers can communicate on a common level.

Normally speaking MIDI is used to play additional devices such as expanders, samplers, synthesizers etc. from a keyboard. Information such as the notes played, the position of the modulation wheel, the position of a foot controller, velocity of key activation etc. are transmitted by MIDI to the units connected.

Effect units like the Fx 70 can also be subjected to MIDI control. Users can program it in such a way that the appropriate effect is always selected when a synthesizer sound is called up. That is possible because the synthesizer always transmits a command to change the program at sound selection. The Fx 70 receives this program change command and then calls up the program allocated to the command in question.

The MIDI specification includes 16 different channels. A MIDI transmitter can control up to 16 different MIDI receiving units completely independently of each other, all at the same time. You can set the MIDI reception channel on the Fx 70 (see chapter 7.1). For correct MIDI transmission you must make sure that the appropriate MIDI channel has also been set on the transmitting unit (keyboard, sequencer, computer). Please read the user manuals of the units in question.

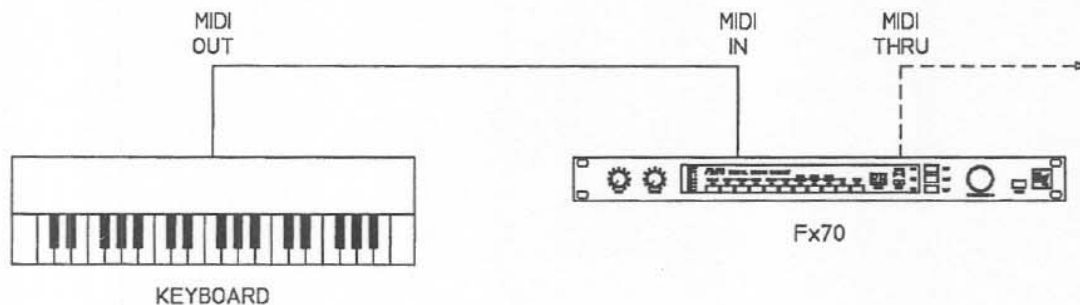

# SPECIFICATIONS

---

## 10. SPECIFICATIONS

Mains voltage	90-250 VAC/50-60 Hz (without switching over)	
Power consumption	max. 13 VA	
Safety class	I	
Input voltage	HI	0.775 V / 0 dBm
	LO	80 mV / -20 dBm
Max. input voltage		9 V / +21 dBm
Input impedance	LO/HI	50 kohms
Output voltage		3.2 V / +12 dBm
Output impedance		120 ohms
Frequency response original	40 Hz - 20 kHz +0 / -3 dB	
Frequency response effect	40 Hz - 20 kHz +0 / -6 dB	
S/N ratio original	> 104 dB	
S/N ratio effect	> 90 dB	
Distortion (THD) original	< 0.003 %	
Distortion (THD) effect	< 0.05 %	
Data format	16 bit linear, internally 24 bit	
MIDI connections	IN/OUT/THRU	
Ground lift	Separates circuit ground from housing	
Dimensions (WxHxD in mm)	483 x 43.6 x 225, 1 HU	
Weight	3.5 kg / 7.7 lbs	
Accessory	FS 223 (Motor ON-OFF / FAST-SLOW) FS 12 (Effect off)	

The specifications for this product are subject to change without prior notice.

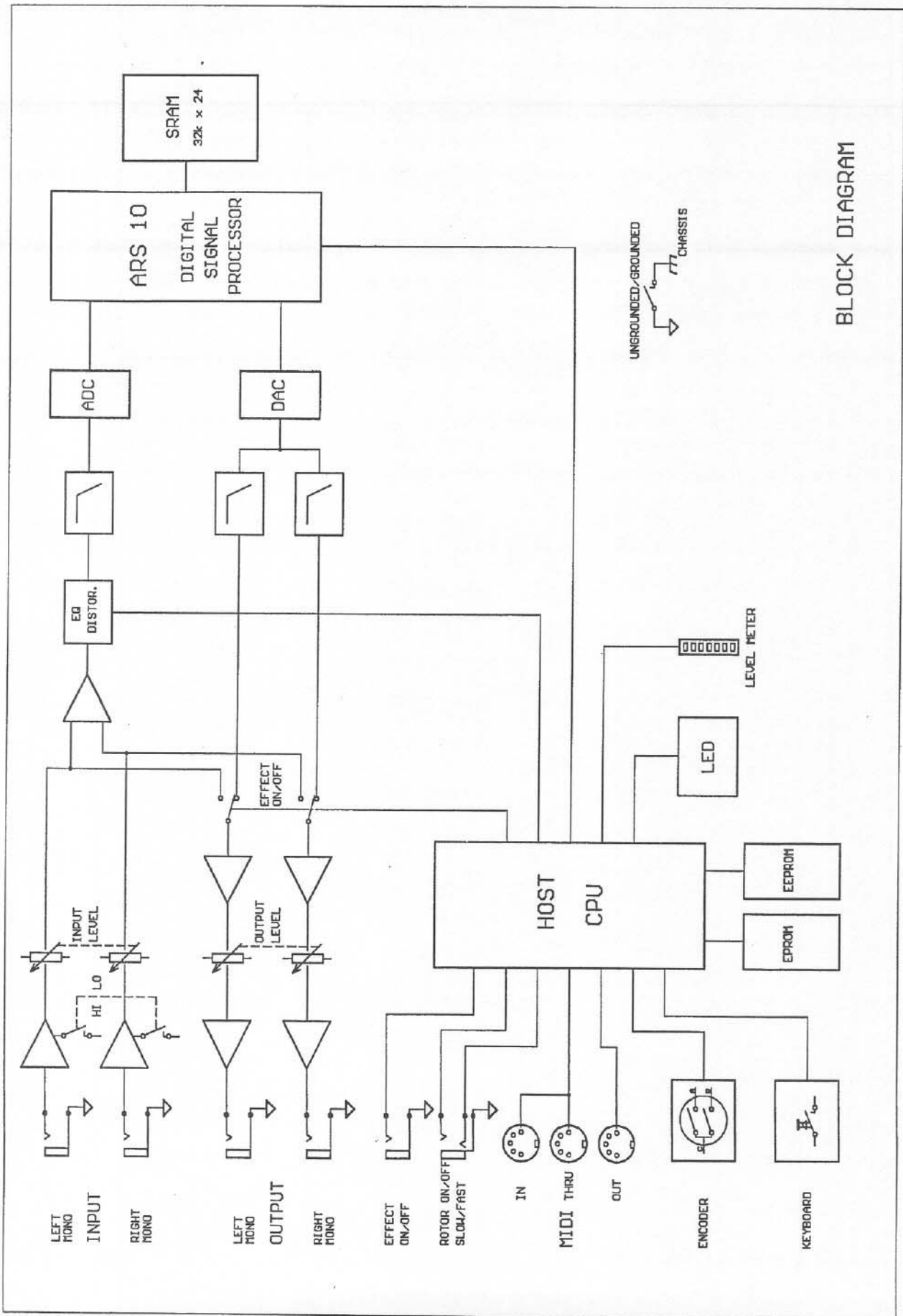

BLOCK DIAGRAM



# DIMENSIONS

Dimensions in mm (inch)

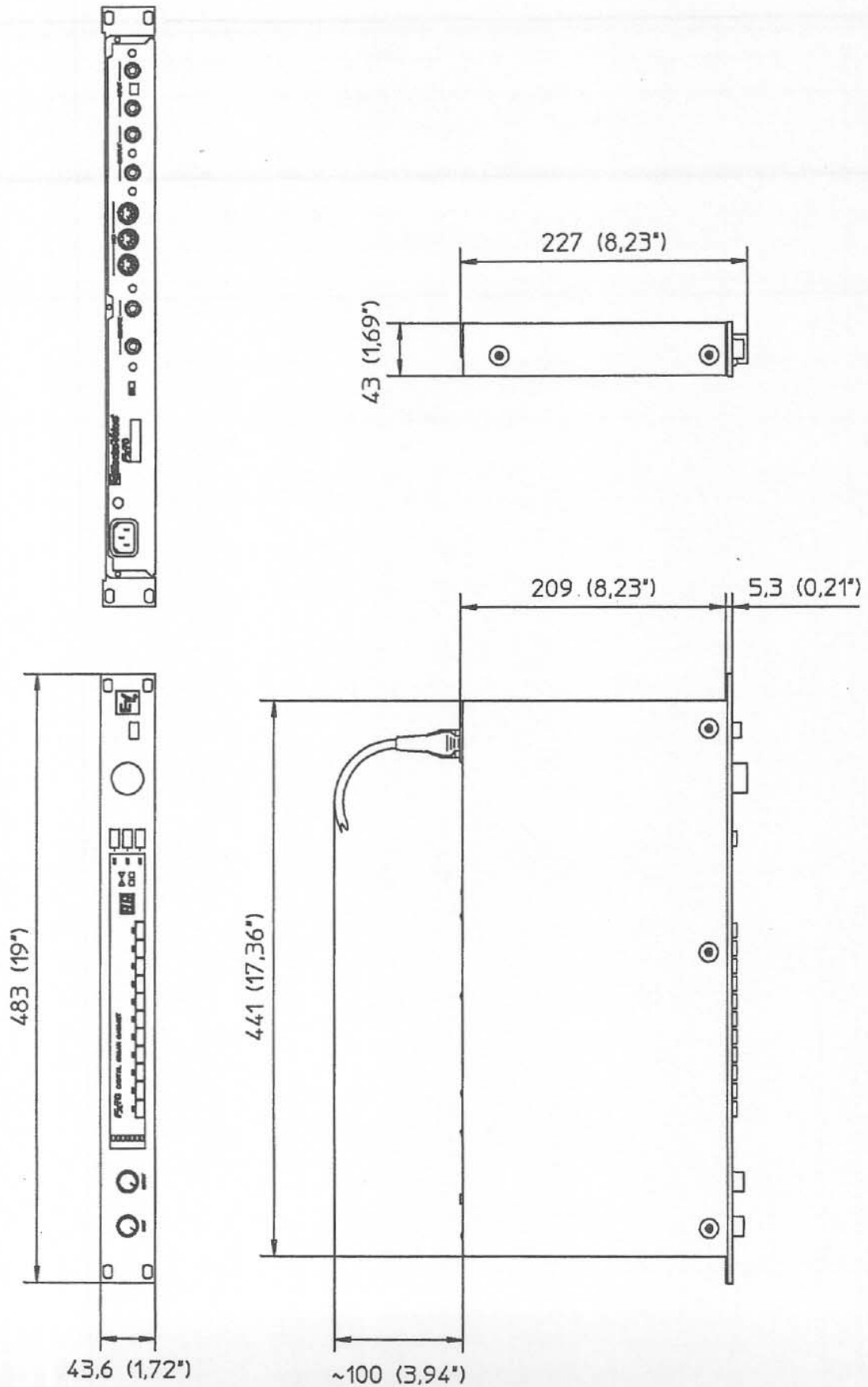

# ***SERVICE***

## MEASURING DATA Fx 70

### Agreements:

- All Level, Frequency Response and Distortion Measurements are performed with "AUDIO PRECISION SYSTEM ONE". Generator impedance 25 ohms, Analyzer impedance 100 kohms.
  - Levels measured with  $f=1$  kHz.
  - The noise levels measured at the outputs refer to the nominal output level of +18dBm.
  - Tolerances of the level values: +/- 1 dB.
  - All Distortion measurements are performed with a measurement bandwidth of 10 Hz - 22 kHz, without filter. Measured is THD+Noise.
  - Measurements at the original signal with EFFECT OFF.
  - 0 dBu = 775 mV rms
  - Operating voltage and current are measured with "PHILIPS MULTIMETER PM 2517X".
  - Power Consumption is measured with "Zäres Wattmeter".
  - Recall of the Service Presets: see table service functions Fx 70 (page 48) and service presets (page 50)
- Note:** For operation of some functions (e.g. storing of programs) and explanation of parameter functions the operating manual is necessary.

1. Operating voltage  $E_{B(V)}$  90 - 250 V<sub>AC</sub>  $f = 50 - 60$  Hz

2. Operating current  $I_{B(A)}$  at 110 V<sub>AC</sub> 150 mA  
at 230 V<sub>AC</sub> 110 mA

3. Power consumption at 110 V<sub>AC</sub> 10.5 VA  
at 230 V<sub>AC</sub> 12.5 VA

### 4. Inputs

- both inputs connected (Stereo operation)

4.1. Input impedance  $Z_i$  = 50 kohms

### 4.2. Input voltage

- Input control fully to the right
- recall service preset 01
- input level switch position HI.

Level indication = 0 dB  $E_i$  = 775 mV = 0dBm  
Level indication = CLIP  $E_{i\max}$  = 1.55 V = +6dBm

- input level switch position LO.

Level indication = 0 dB  $E_i$  = 95 mV = -18dBm  
Level indication = CLIP  $E_{i\max}$  = 175mV = -12dBm

## 5. Outputs

- both outputs connected (Stereo operation)
- the output levels measured refer to an input level of  $E_i = 0\text{dBm}$  and  $E_{i\text{max}} = +6\text{dBm}$ . Input and output level controls fully to the right, input selector into position HI.

### 5.1. Output impedance

$Z_o = 120\text{ ohms}$

### 5.2. Output voltage left:

$E_o = 3.2\text{ V} = +12\text{dBm}$

$E_{o\text{max}} = 6.4\text{ V} = +18\text{dBm}$

### 5.3. Output voltage right:

$E_o = 3.2\text{ V} = +12\text{dBm}$

$E_{o\text{max}} = 6.4\text{ V} = +18\text{dBm}$

## 5.4. Frequency response

### 5.4.1 Frequency response - original signal

- Input level selector into position HI, effect OFF.
- Input level  $0\text{dBm}$ .
- Input control fully right, output control adjusted to  $0\text{dBm}$ .

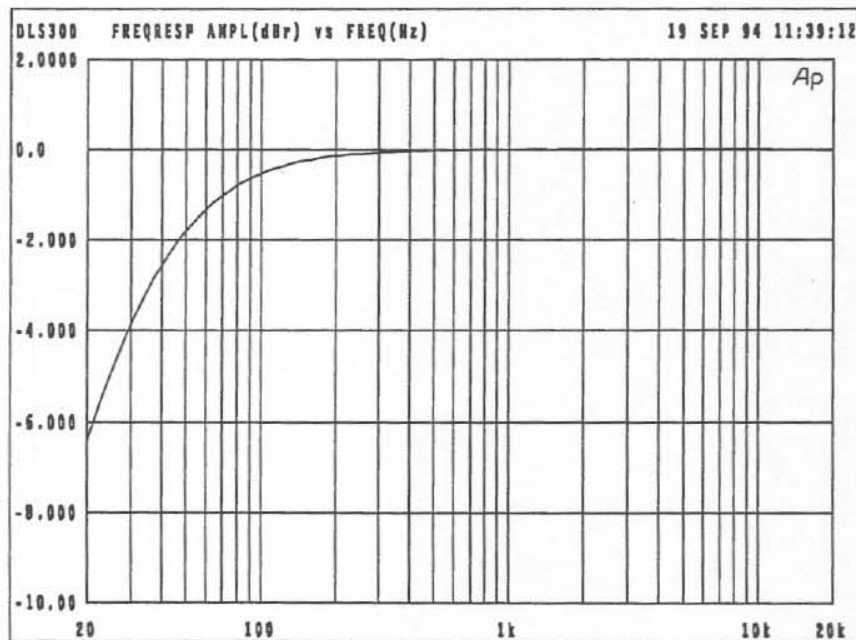

### 5.4.2 Frequency response - effect signal

- Input level selector into position HI, effect ON.
- Service preset 01 recalled.
- Input level  $0\text{dBm}$ .
- Input control fully right, output control adjusted to  $0\text{dBm}$ .

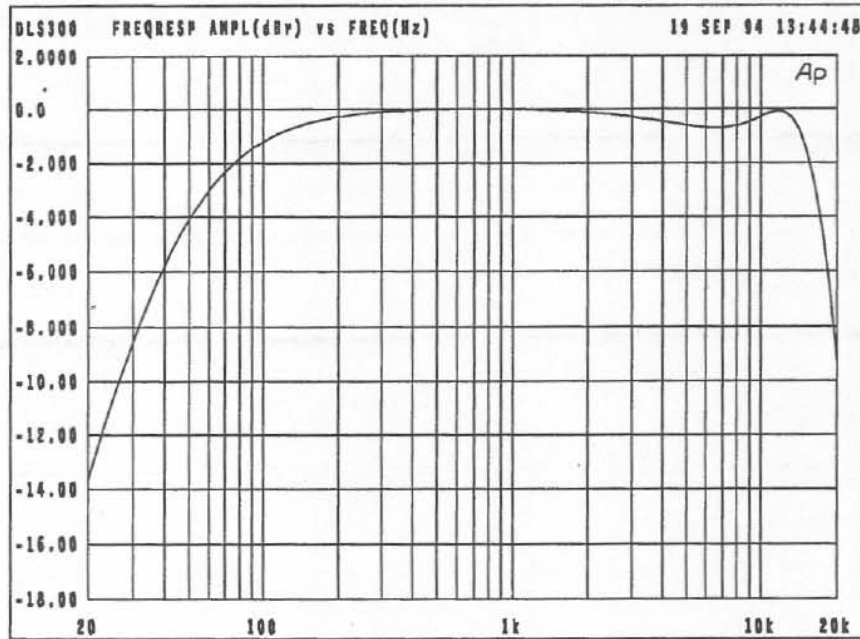

### 5.4.3 Frequency response - EQ

- Input level selector into position HI, effect ON.
- Input level -6dBm.
- Input control fully right, output control adjusted to 0dBm.

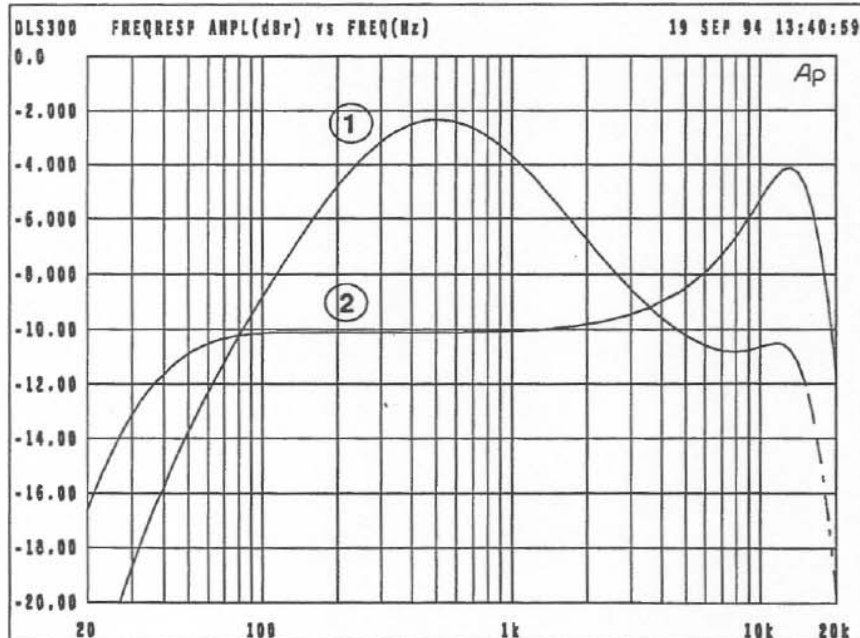

### EQ controls pre distorter

Plot 1: Service preset 08 recalled

Plot 2: Service preset 09 recalled



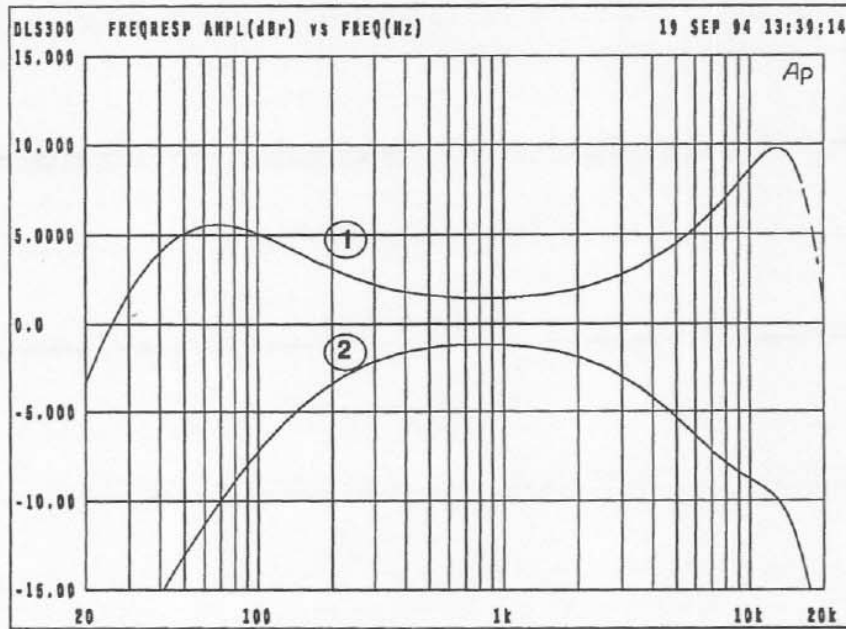

**EQ controls post distorter**

Plot 1: Service preset 10 recalled

Plot 2: Service preset 11 recalled

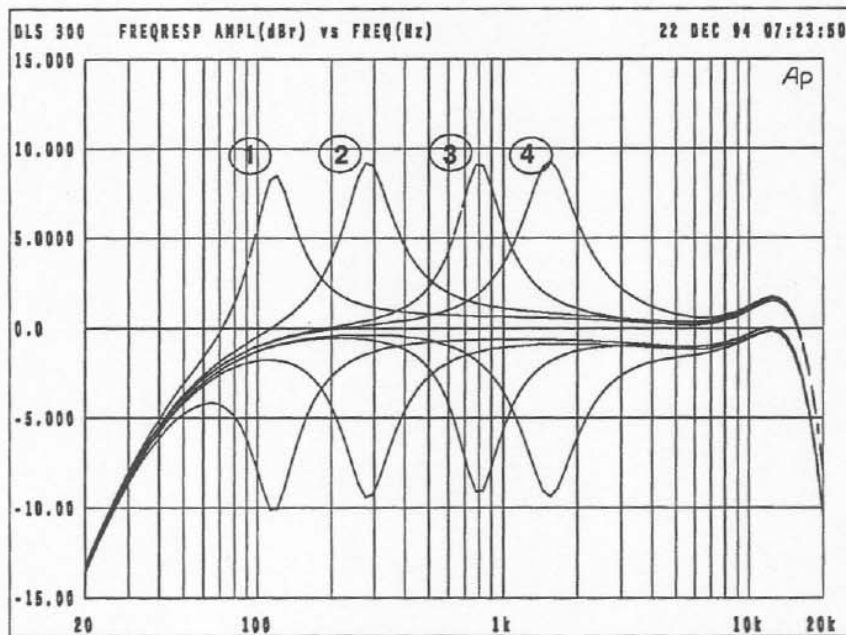

**Frequency response of the EQ**

- Service preset 01 recalled

Plot 1: 125Hz Param. control 28 (+/-5)

Plot 2: 300Hz Param. control 29 (+/-5)

Plot 3: 800Hz Param. control 30 (+/-5)

Plot 4: 1.5kHz Param. control 31 (+/-5)

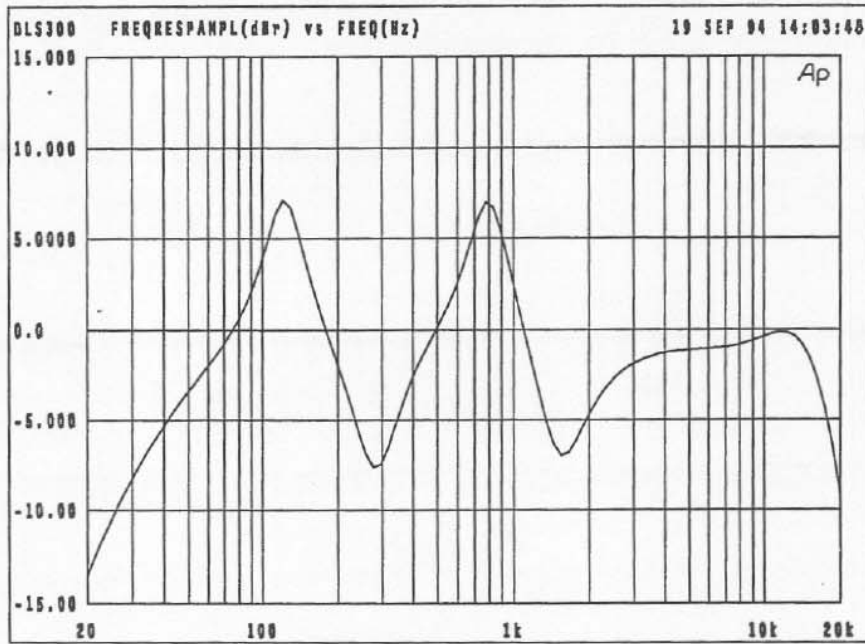

Frequency response of the EQ

- Service preset 12 recalled

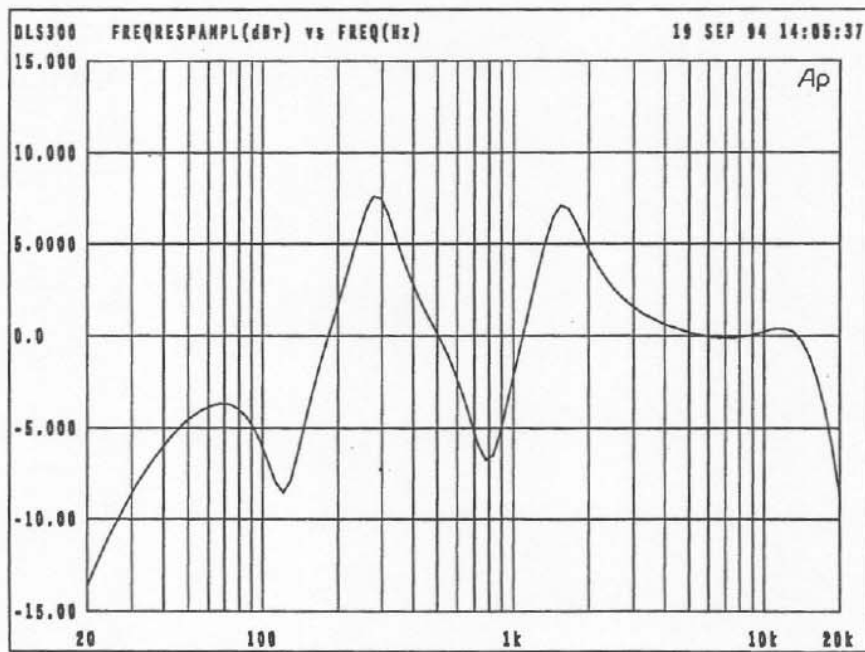

Frequency response of the EQ

- Service preset 13 recalled

## 5.5. Distortion (THD)

### 5.5.1 Distortion (THD) - original signal

- Input level selector into position HI, effect OFF.
- Input level +10dBm.
- Input and output controls fully right.

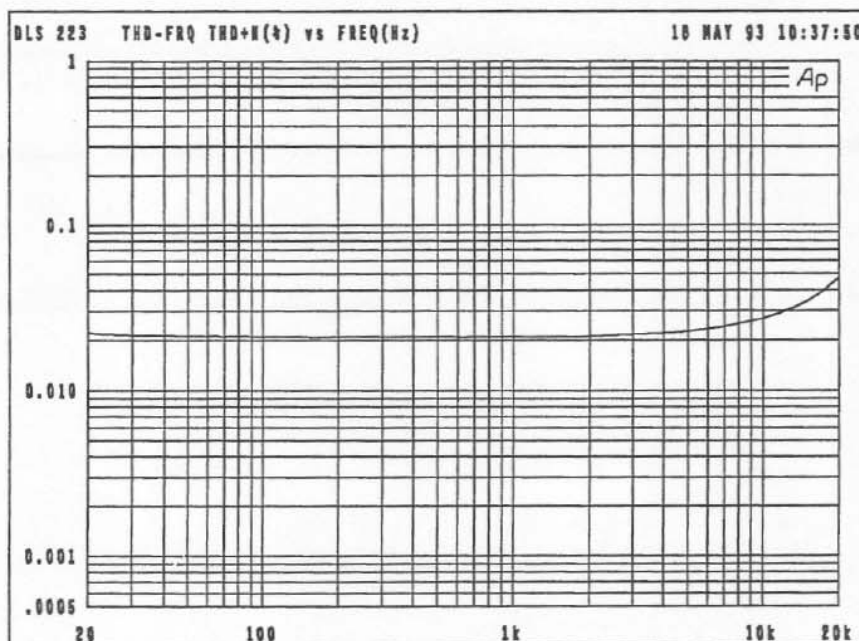

### 5.5.2 Distortion (THD) - effect signal

- Input level selector into position HI, effect ON.
- Input level -10dBm.
- Service preset 01 recalled.

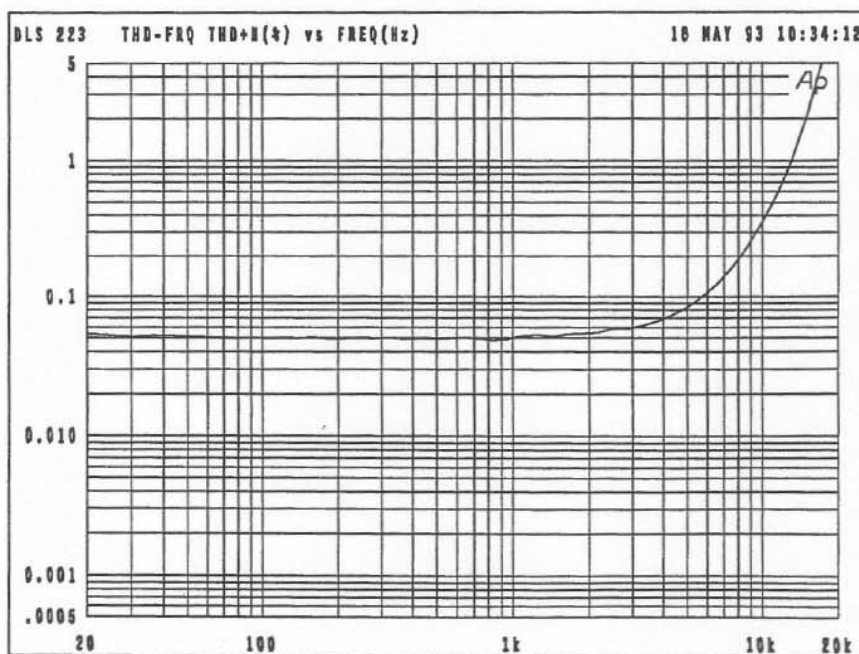

### 5.5.3 Distortion (THD) - Distortion

- Input level selector into position HI, effect ON.
- Input level -14dBm.
- Input and output controls fully right.

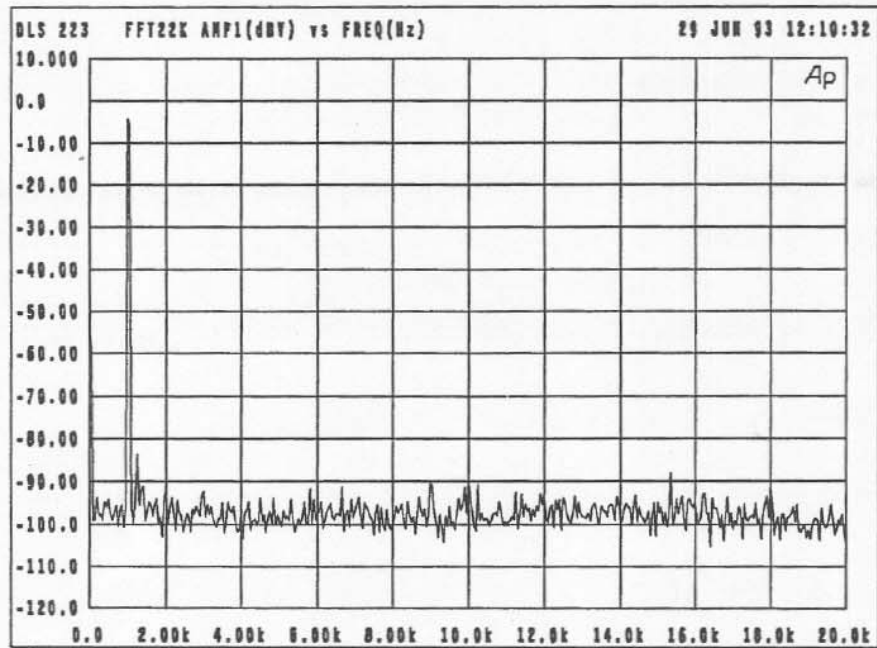

- Service preset 01 recalled  
(Distortion control in position 0)

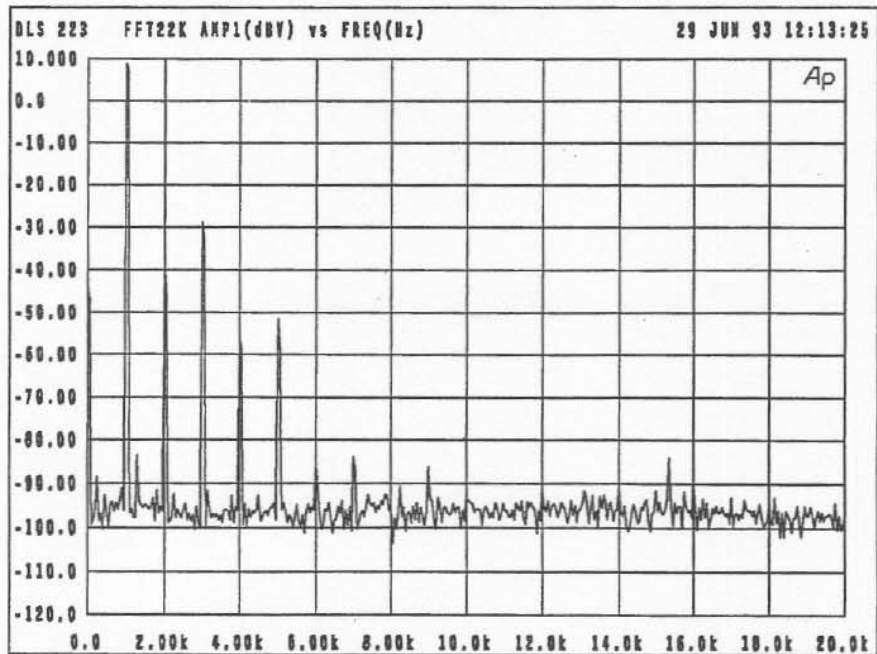

- Service preset 16 recalled  
(Distortion control in position 5)

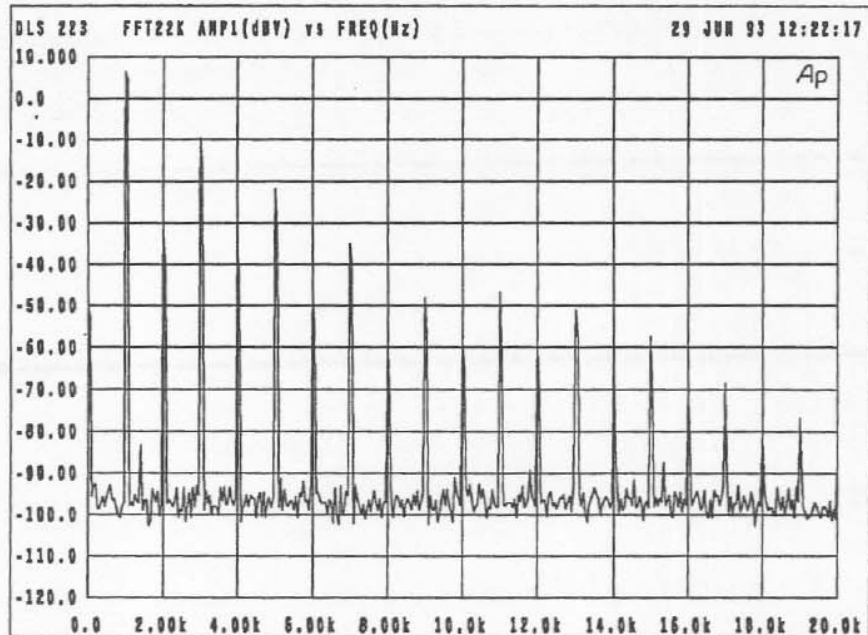

- Service preset 17 recalled  
(Distortion control in position 15)

### 5.6. Noise voltages

- All specifications are valid for the left and right output
- Service preset 01 recalled
- Input and Output control fully to the right

#### 5.6.1. Noise voltage - original signal

- Input level selector into position HI, effect OFF.

E <sub>O</sub> weight.(RMS)	15μV	112dB
E <sub>noise</sub> (Q-peak)	32μV	106dB
E <sub>CIRR</sub> (Q-peak)	65μV	100dB

- Input level selector into position LO, effect OFF.

E <sub>O</sub> weight.(RMS)	85μV	96dB
E <sub>noise</sub> (Q-peak)	200μV	90dB
E <sub>CIRR</sub> (Q-peak)	400μV	84dB

#### 5.6.2. Noise voltage - effect signal

- Input level selector into position HI or LO, effect ON.

E <sub>O</sub> weight.(RMS)	150μV	91dB
E <sub>noise</sub> (Q-peak)	350μV	85dB
E <sub>CIRR</sub> (Q-peak)	650μV	80dB

### 5.7. Crosstalk

between left and right

> 70dB



## Service functions Fx 70 Version 2.0

Recall of the Service Mode by pressing the keys "DISTORTION" and "SPEED TREBLE" simultaneously over a long time. Exit of Service Mode by pressing the key "STORE".

### Function and Parameter Values in the Service Mode

SPEED BASS	SPEED TREBLE
Index	Date
00	PRESET-RECALL (1...3) see Service-Rom Presets
01	DISTORTION (0...15)
02	ROOM (0...15)
03	ROTOR-BALANCE (-9...9)
04	SPEED BASS (0...99)
05	SPEED TREBLE (0...99)
06	SLOW/FAST-RATIO BASS (0...99)
07	SLOW/FAST-RATIO TREBLE (0...99)
08	SPEED-UP BASS (0...99)
09	SPEED-UP TREBLE (0...99)
10	SPEED-REDUCE BASS (0...99)
11	SPEED-REDUCE TREBLE (0...99)
12	ROTATE-DIRECTION BASS (C / AC)
13	ROTATE-DIRECTION TREBLE (C / AC)
14	FAST-FREQU-VIBRATO BASS (0...15)
15	FAST-FREQU-VIBRATO TREBLE (0...15)
16	SLOW-FREQU-VIBRATO BASS (0...15)
17	SLOW-FREQU-VIBRATO TREBLE (0...15)
18	LIVENESS BASS (-7...7)
19	LIVENESS TREBLE (-7...7)
20	CONTUR BASS (0...31)
21	CONTUR TREBLE (0...31)
22	PANORAMA BASS (0...7)
23	PANORAMA TREBLE (0...7)
24	ROOM-SIZE (0...15)
25	CROSSOVER-FREQUENCY (0...3)
26	ACTIVE-EQ BASS 30HZ (-5...5)
27	ACTIVE-EQ TREBLE 20KHZ (-5...5)
28	ACTIVE-EQ BAND 125HZ (-5...5)
29	ACTIVE-EQ BAND 300HZ (-5...5)
30	ACTIVE-EQ BAND 800HZ (-5...5)
31	ACTIVE-EQ BAND 1,5KHZ (-5...5)
32	PASSIVE-EQ BASS (-5...0)
33	PASSIVE-EQ MID (-5...0)
34	PASSIVE-EQ TREBLE (-5...0)
35	OUTPUT-LEVEL (--...7..7)
36	STOP-DIRECTION (0 / 1)
37	BASS POSITION (bass rotor in the tens digit
38	TREBLE POSITION (and the horn rotor in the units digit)
39	BASS TACHO (0...99, Display, no Edit)
40	TREBLE TACHO (0...99, Display, no Edit)
41	PEAKHOLD-ZEIT (0...42)
42	MIDI-SYSEX-REMOTE ENABLE (0 / 1)
43	VU-SELEKTION (i/o/L/r and combinations)
44	EQ-GAIN F1 (-5...5) Gain-correction
45	EQ-GAIN F2 (-5...5) Bass 30Hz

46	EQ-GAIN F3	(-5...5) Band 300Hz
47	EQ-GAIN F4	(-5...5) Band 800Hz
48	EQ-GAIN F5	(-5...5) Band 125Hz
49	EQ-GAIN F6	(-5...5) Band 1,5kHz
50	EQ-GAIN F7	(-5...5) Treble 20kHz
51	EQ-GAIN F1*	(-5...5) Distortion in
52	EQ-GAIN F2*	(-5...5) Distortion out
53	EQ-GAIN F3*	(-5...5) Compensation in
54	EQ-GAIN F4*	(-5...5) Compensation out
55	EQ-GAIN F5*	(-5...5) Bass cut 30Hz
56	EQ-GAIN F6*	(-5...5) Middle cut 800Hz
57	EQ-GAIN F7*	(-5...5) Treble cut 18kHz
58	SERVICE-RECALL	(...10) see Service-Routines
59	OFFSET-COMPENSATION	(0 / 1)

70	ADRSCL1TP	(00h...FFh)
71	ADRSCL3STP	(80h...7Fh)
72	ADRSCL3STP	(00h...FFh)
73	ADRSCL3LTP	(80h...7Fh)
74	ADRSCL3LTP	(00h...FFh)

75	ADRSCL1HP	(00h...FFh)
76	ADRSCL3SHP	(80h...7Fh)
77	ADRSCL3SHP	(00h...FFh)
78	ADRSCL3LHP	(80h...7Fh)
79	ADRSCL3LHP	(00h...FFh)

80	ORIGAINTP	(80h...7Fh)
81	VCOGAINSTP	(80h...7Fh)
82	VCOGAINSTP	(80h...7Fh)
83	GAINSCLO00TP	(F0h...10h)
84	GAINSHIFT000TP	(80h...7Fh)
85	GAINSCLO90TP	(F0h...10h)
86	GAINSHIFT090TP	(80h...7Fh)
87	GSUMSHIFT090TP	(80h...7Fh)

90	ORIGAINTP	(80h...7Fh)
91	VCOGAINSTP	(80h...7Fh)
92	VCOGAINSTP	(80h...7Fh)
93	GAINSCLO00TP	(F0h...10h)
94	GAINSHIFT000TP	(80h...7Fh)
95	GAINSCLO90TP	(F0h...10h)
96	GAINSHIFT090TP	(80h...7Fh)
97	GSUMSHIFT090TP	(80h...7Fh)

## Service Presets Fx 70

Presets are selected via Index 00 (see service functions). Presets are called up using the rotary encoder and are immediately valid without confirming with Enter. These presets can be edited and stored as usual (see 5.4 Storing of programs in the Operating Manual).

SPEED TREBLE
Number

- 1 Original Through (EQ linear)
- 2 Original Through only Right (EQ linear)
- 3 Original Through only Left (EQ linear)
- 4 Muted
- 5 Sine Output Left and Right
- 6 Sine Output only Right
- 7 Sine Output only Left
- 8 Frequency Response Bass and Trebles cut
- 9 Frequency Response Middle cut
- 10 Frequency Response Bass and Trebles boost
- 11 Frequency Response Bass and Trebles cut
- 12 Frequency Response Bands Pattern 1
- 13 Frequency Response Bands Pattern 2
- 14 Frequency Response all Bands fully cut
- 15 Frequency Response all Bands fully boosted
- 16 Original Through with Distortion 5
- 17 Original Through with Distortion 15
- 18 Level correction boosted individually
- 19 Level correction cut individually
- 20 Compensation in/out individually
- 21 Distortion in/out individually
- 22 Clean Leslie, only bass rotor, crossover minimum
- 23 Clean Leslie, only horn rotor, crossover minimum
- 24 Clean Leslie, only bass rotor, crossover maximum
- 25 Clean Leslie, only horn rotor, crossover maximum

## Service Routines Fx 70

Service Routines are called up via Index 58 (see service functions). After pressing the "SPEED TREBLE" key a service routine can be selected (see table below). The selected Service Routine starts after pressing the "STORE" key.

SPEED TREBLE
Number

STORE
Execution

- 0 NO CHANGE RETURN
- 1 SOFTWARE RESET
- 2 DISPLAY SOFTWARE VERSION
- 3 DISPLAY ROM CHECK SUM  
Output of the 16 bit-wide additive 8 bit check sum of the EPROM 27256 (address range 8000h...FFFFh) as 2 successive Hex figures (MSByte, LSByte) in the seven-segment display.

The current EEPROM content is saved in the ARS system, two inverse test patterns are written, verified and subsequently the original data from the ARS system is written back. While this procedure is in progress, the decimal point of the 10th digit lights up. If the decimal point goes off afterwards, the procedure was Ok. If the decimal point flashes on and off constantly, (even in normal operation), this indicates an EEPROM error. The real EEPROM test via test pattern does not depend on the function of the ARS system, as this is only used as an intermediate memory for the current data. If the ARS system is not working, the EEPROM data is lost nevertheless.

5 SAVE EEPROM DATA VIA SYSEX

The current EEPROM content is transmitted to the Midi Output via MIDI system exclusive messages, without involving the ARS system. This data can be recorded and later played back into the unit. The ARS system must be working, however, for this procedure to be carried out.

6 DELETING EEPROM DATA

The current EEPROM content is deleted completely (returns to original). The Fx 70 then reads all data from the EPROM.

7 LED TEST PATTERN

The following test patterns are issued to the LED driver: 111111... (= all LED's light up), 101010... (every second LED lights), 010101... (= every second LED dark), 000000... (= all LED's dark).

8 MIDI TEST 31.25 KBAUD WITH EXTERNAL CLOCK DIVIDER

A test pattern is issued at the MIDI OUT and is then checked at the MIDI IN. Therefore a connection between MIDI OUT and MIDI IN must be made. When all displays go dark briefly, and the unit resumes its normal function, the test was OK. The seven-segment display indicates the following possible errors: "E.1" for Timeout Error, "E.2" for Framing Error, "E.3" for Data Error and "E.4" for Overrun Error.

9 MIDI TEST 62.5 KBAUD WITH INT. CLOCK DIVIDER

As before, whereas here, the CPU internal frequency divider is used instead of the CPU external frequency divider (/4).

10 KEYBOARD TEST

The keyboard is interrogated without software debouncing and one number of whatever key has been pressed is indicated in the display. In the case of keys on the front PCB, the corresponding LED is also activated. The key number "00" represents "no key pressed" and "--" for "several keys pressed". The Remote foot switches and not printed Service keys are also numbered, resulting in the key numbers "01" to "24". This test is only concluded with Hardware Reset (Power O





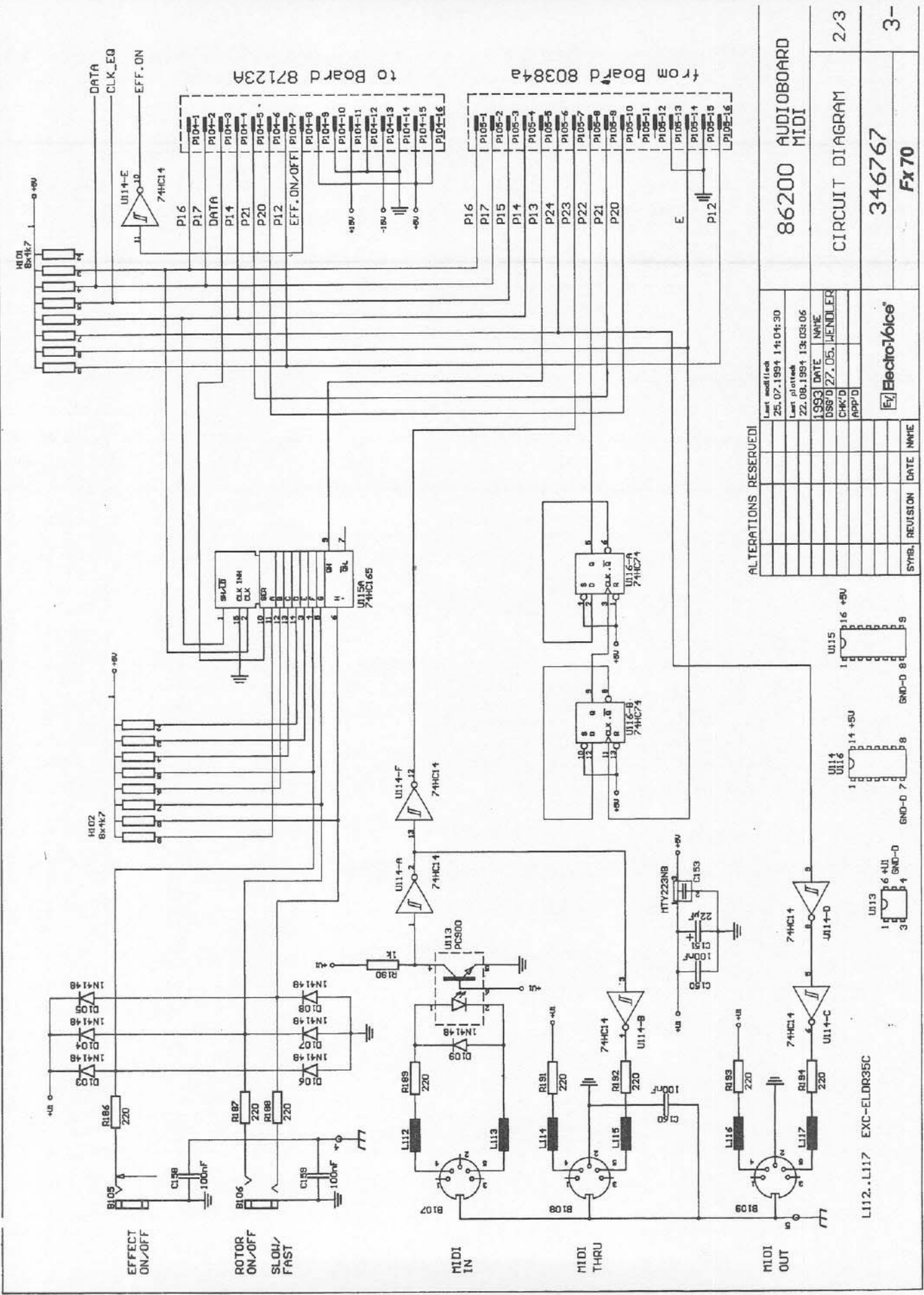

to Board 871234

from Board 80384a

ALTERATIONS RESERVED!

Last modified	25.07.1994 14:04:30
Last plotted	22.08.1994 13:03:06
1993 DATE	N/A
DRG'D	27.05.1994
CHK'D	
APP'D	

ElectroVoice®

SYMB.	REVISION	DATE	NAME

86200 AUDIOBOARD MIDI

CIRCUIT DIAGRAM

2/3

346767  
Fx70

L112..L117 EXC-ELDR35C

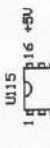







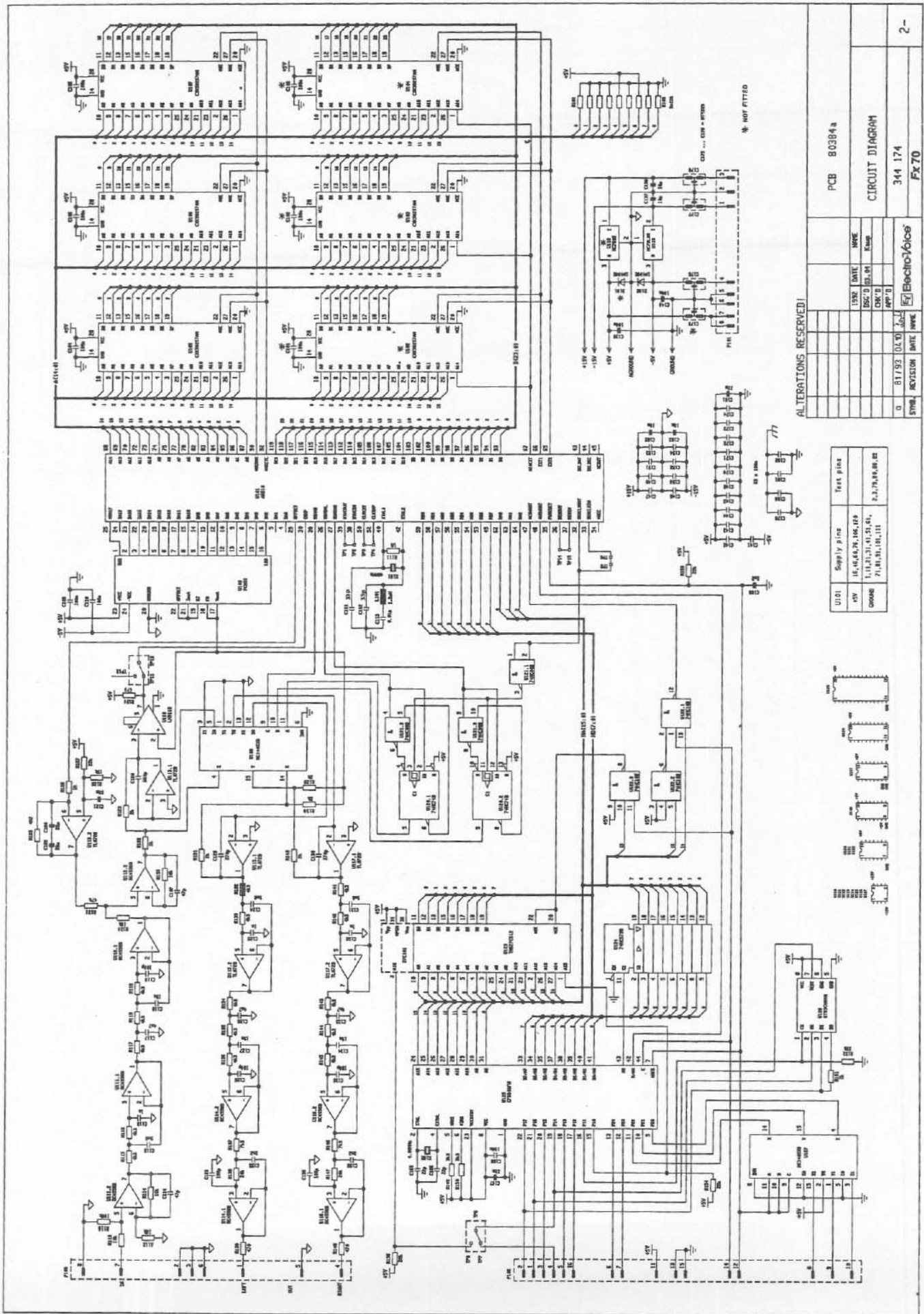

U1A1	Supply pin	Test pin
U1A	14, 16, 17, 18, 19, 20, 21, 22, 23, 24, 25, 26, 27, 28, 29, 30, 31, 32, 33, 34, 35, 36, 37, 38, 39, 40	1, 2, 3, 4, 5, 6, 7, 8, 9, 10, 11, 12, 13, 14, 15, 16, 17, 18, 19, 20, 21, 22, 23, 24, 25, 26, 27, 28, 29, 30, 31, 32, 33, 34, 35, 36, 37, 38, 39, 40

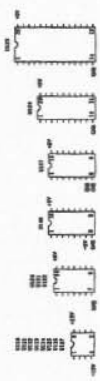

ALTERATIONS RESERVED!

PCB 80384	CIRCUIT DIAGRAM	344 174	Fx 70
DATE	DATE	DATE	DATE
DESIGN	DESIGN	DESIGN	DESIGN
CHK'D	CHK'D	CHK'D	CHK'D
APP'D	APP'D	APP'D	APP'D
Q. 81793 (U. 0)	Electronics		
SYMBOL	REVISION	DATE	NAME



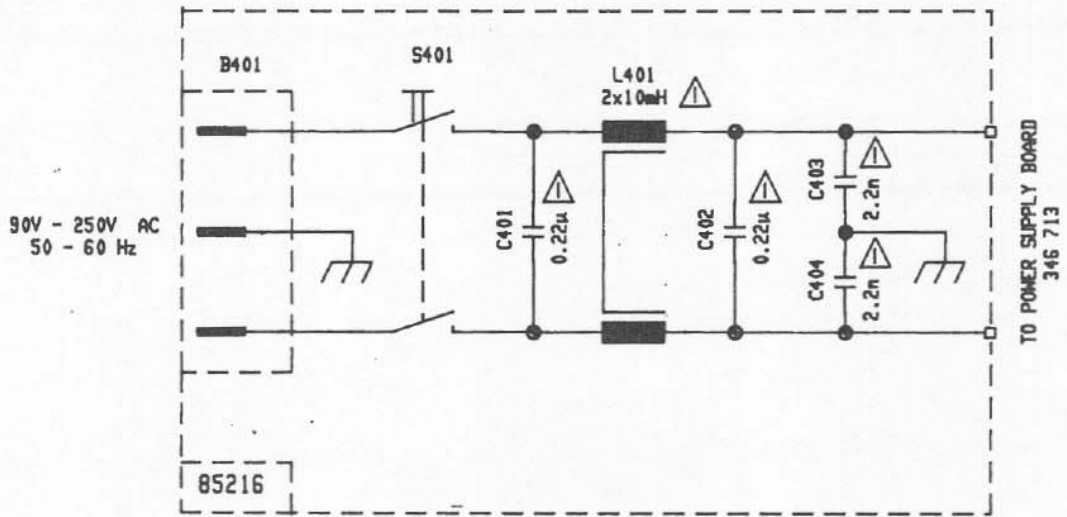

SAFETY COMPONENT  
(MUST BE REPLACED BY ORIGINAL PART)



Pos. in diagram	description	Part-No.	Pos. in diagram	description	Part-No.
Z 020	rubber foot	345095	D 110	diode 1N 4148	301254
00010	plexi glas Fx 70	351147	D 111	diode 1N 4148	301254
00030	push button grey	344280	E 101	relay AZ 845	346760
00040	push button black 12,5x7	337059	H 101	resistor netw RKL 9S 472J	336378
00050	push button black 6,4x 13,4	342496	H 102	resistor netw RKL 9S 472J	336378
00060	rotary knob black 16	342120	L 101	coil	339139
00070	rotary knob black 24	348055	L 102	coil	339139
00080	power supply	346713	L 103	coil	339139
			L 104	coil	339139
00010	PCB	804108	L 105	coil	339139
C 175	safety component	343489	L 106	coil	339139
C 176	safety component	343489	L 107	coil	339139
C 177	safety component	343489	L 108	coil	339139
C 178	safety component	343489	L 109	coil 47 UH	335966
D 101	diode 1N 4002	304360	L 110	coil 47 UH	335966
D 102	diode 1N 4002	304360	L 111	coil 47 UH/5,5A	333717
L 101	coil LAP-02TA-1R2K	344199	L 112	coil	339139
U 118	IC MC 7805 C	309719	L 113	coil	339139
U 119	IC MC 79 L 05 ACP	309721	L 114	coil	339139
X 101	quarz 48.0000MHZ	346787	L 115	coil	339139
X 102	quartz 4.0000MHZ	331341	L 116	coil	339139
			L 117	coil	339139
00020	PCB	852328	Q 101	trans. BC 550 B	301184
B 401	connector	338835	R 126	potentiometer 2x5kohm log	345484
C 401	safety component 0,22MF	344934	R 127	potentiometer 2x5kohm log	345484
C 402	safety component 0,22MF	344934	S 101	switch	344037
C 403	safety component 2.2NF	334682	S 102	sliding switch	338886
C 404	safety component 2.2NF	334682	U 101	IC RC 4558 P	304275
L 401	coil 2x 10 MH	332961	U 102	IC NJM 4556 D	344864
S 401	mains switch	331175	U 103	IC RC 4558 P	304275
			U 104	IC RC 4558 P	304275
00030	PCB	862008	U 105	IC RC 4558 P	304275
B 101	phone jack	332352	U 106	IC RC 4558 P	304275
B 102	phone jack	332352	U 107	IC RC 4558 P	304275
B 103	phone jack	332352	U 108	IC RC 4558 P	304275
B 104	phone jack	332352	U 109	IC RC 4558 P	304275
B 105	phone jack	332352	U 110	IC RC 4558 P	304275
B 106	phone jack HLJ	332353	U 111	IC RC 4558 P	304275
B 107	socket	303093	U 112	IC LC 7520	346830
B 108	socket	303093	U 113	IC PC 900	333739
B 109	socket	303093	U 114	IC MC 74 HC 14	333458
C 129	KO-FOL 0.33MF 63V	340244	U 115	IC MC 74 HC165 N	346829
C 153	safety component	343489	U 116	IC MC 74 HC 74 N	339704
C 172	KO-EL 220 MF 25V	343533			
D 101	diode 1N 4148	301254	00040	PCB	871238
D 102	diode zener ZPD 10V	301309	D 201	display TDSR 1150 G	346828
D 103	diode 1N 4148	301254	D 202	display TDSR 1150 G	346828
D 104	diode 1N 4148	301254	D 203	LED red	345450
D 105	diode 1N 4148	301254	D 204	LED red	345450
D 106	diode 1N 4148	301254	D 205	LED red	345450
D 107	diode 1N 4148	301254	D 206	LED red	345450
D 108	diode 1N 4148	301254	D 207	LED red	345450
D 109	diode 1N 4148	301254	D 208	LED red	345450



Pos. in diagram	description	Part-No.	Pos. in diagram	description	Part-No.
D 209	LED red	345450			
D 210	LED red	345450			
D 211	LED red	345450			
D 212	LED red	345450			
D 213	LED red	345450			
D 214	LED red	345450			
D 215	LED red	345450			
D 216	LED red	345450			
D 217	led red 6x3.8mm	348453			
D 218	led red 6x3.8mm	348453			
D 219	led green 6x3.8mm	348454			
D 220	led green 6x3.8mm	348454			
D 221	led green 6x3.8mm	348454			
D 222	led green 6x3.8mm	348454			
D 223	led green 6x3.8mm	348454			
D 224	diode BAT 85	301297			
D 225	diode 1N 4148	301254			
D 226	led yellow 6x11 mm	346827			
D 227	LED green 6x11mm	331266			
D 228	led yellow 6x11 mm	346827			
D 229	LED green 6x11mm	331266			
H 201	resistor netw RKL 6S 103J	337954			
H 202	resistor netw RKL 6S 103J	337954			
H 203	resistor netw RKL 6S 103J	337954			
H 204	resistor netw RKL 6S 103J	337954			
Q 201	trans. BC 550 B	301184			
Q 202	trans. BC 550 B	301184			
Q 203	trans. BC 550 B	301184			
Q 204	trans. BC 550 B	301184			
Q 205	trans. BC 550 B	301184			
S 201	switch	339674			
S 202	switch	339674			
S 203	switch	339674			
S 204	switch	339674			
S 205	switch	339674			
S 206	switch	339674			
S 207	switch	339674			
S 208	switch	339674			
S 209	switch	339674			
S 210	switch	339674			
S 211	switch	339674			
S 212	switch	339674			
S 213	switch	339674			
S 214	switch	339674			
S 215	rotary encoder	346797			
U 201	IC MC 74 HC165 N	346829			
U 202	IC MC 74 HC165 N	346829			
U 203	IC RC 4558 P	304275			
U 204	IC RC 4558 P	304275			
U 205	IC MC 14411	333261			
U 206	IC UAA 2022 P	333487			
U 207	IC UAA 2022 P	333487			
U 208	IC UAA 2022 P	333487			

## # SERVICE INFORMATION

**WARNING:** No user serviceable parts inside. Extremely hazardous voltages and currents may be encountered within the chassis. The servicing information contained within this document is only for use by Electro-Voice Authorized warranty repair stations and qualified service personnel. To avoid electric shock DO NOT perform any servicing other than that contained in the Operating instructions unless you are qualified to do so. Otherwise, refer all servicing to qualified service personnel.

**NOTICE:** Modification to Electro-Voice products is not recommended. Such modifications shall be at the sole expense of the person(s) or company responsible, and any damage resulting therefrom shall not be covered under warranty or otherwise.

### #.1 ORDERING REPLACEMENT PARTS

TO ORDER REPLACEMENT PARTS, LOOK UP THE ORDERING NUMBER FROM THE COMPONENT PARTS LISTING AND CALL E. S. T. (616) 695-6831, FAX (800) 685-6386, OR WRITE:

ELECTRO-VOICE SERVICE  
600 CECIL STREET  
BUCHANAN, MICHIGAN 49107  
U. S. A.

### #.2 ELECTRO-VOICE UNIFORM LIMITED WARRANTY STATEMENT

Electro-Voice products are guaranteed against malfunction due to defects in materials or workmanship for a specified period, as noted in the individual product-line statement(s) below, or in the individual product data sheet or owner's manual, beginning with the date of original purchase. If such malfunction occurs during the specified period, the product will be repaired or replaced (at our option) without charge. The product will be returned to the customer prepaid. **Exclusions and Limitations:** The Limited Warranty does not apply to: (a) exterior finish or appearance; (b) certain specific items described in the individual product-line statement(s) below, or in the individual product data sheet or owner's manual; (c) malfunction resulting from use or operation of the product other than as specified in the product data sheet or owner's manual; (d) malfunction resulting from misuse or abuse of the product; or (e) malfunction occurring at any time after repairs have been made to the product by anyone other than Electro-Voice or any of its authorized service representatives. **Obtaining Warranty Service:** To obtain warranty service, a customer must deliver the product, prepaid, to Electro-Voice or any of its authorized service representatives together with proof of purchase of the product in the form of a bill of sale or receipted invoice. A list of authorized service representatives is available from Electro-Voice at 600 Cecil Street, Buchanan, MI 49107 (616/695-6831 or 800/685-2606). **Incidental and Consequential Damages Excluded:** product repair or replacement and return to the customer are only remedies provided to the customer. Electro-Voice shall not be liable for any incidental or consequential damages including, without limitation, injury to persons or property or loss of use. Some states do not allow the exclusion or limitation of incidental or consequential damages so the above limitation or exclusion may not apply to you. **Other Rights:** This warranty gives you specific legal rights, and you may also have other rights which vary from state to state.

**Electro-Voice Electronics** are guaranteed against malfunction due to defects in materials or workmanship for a period of three (3) years from the date of original purchase. Additional details are included in the Uniform Limited Warranty statement.

### #. 3 Technical Assistance

For applications assistance or other technical information, contact the Applications Engineer. You can call (616) 695-6831, FAX (616) 695-1304, or write:

Electro-Voice Applications Engineer 600 Cecil Street Buchanan, MI 49107 U. S. A.

Electro-Voice



EVI Audio, 600 Cecil Street, Buchanan, Michigan 49107, Phone (616) 695-6831, Fax: (616) 695-1304  
EVI Audio, 8234 Doe Avenue, Visalia, California 93291, Phone (209) 651-7777, Fax: (209) 651-0164  
EVI Audio Canada. Inc. 345 Herbert St., Gananoque, Ontario, Canada K7G 2V1, Phone (613) 382-2141,  
Fax (613) 382-7466

## Free Manuals Download Website

<http://myh66.com>

<http://usermanuals.us>

<http://www.somanuals.com>

<http://www.4manuals.cc>

<http://www.manual-lib.com>

<http://www.404manual.com>

<http://www.luxmanual.com>

<http://aubethermostatmanual.com>

Golf course search by state

<http://golfingnear.com>

Email search by domain

<http://emailbydomain.com>

Auto manuals search

<http://auto.somanuals.com>

TV manuals search

<http://tv.somanuals.com>