

Electro-Voice®

a MARK IV company

MC8A MC12A MICHIGAN® Component Speakers

SPECIFICATIONS

Frequency Response in Recommended Vented Enclosure, 1 Meter on Axis, Half-Space Anechoic Environment, Swept One-Third-Octave Random Noise, ± 6 dB

MC8A — 42-20,000 Hz
MC12A — 32-11,000 Hz

Low-Frequency Acoustic Power Output vs. Frequency, Small Signal, in Recommended Vented Enclosure

3-dB-Down
MC8A — 50 Hz
MC12A — 40 Hz

10-dB-Down
MC8A — 37 Hz
MC12A — 27 Hz

Sound Pressure Level at 1 Meter, 1 Watt into Nominal Impedance, Anechoic Environment, 300-2,000 Hz Average

MC8A — 97 dB
MC12A — 97 dB

Power Handling Capacity

Long-Term Average
MC8A — 12 watts
MC12A — 20 watts

Short-Term (10 milliseconds)
MC8A — 120 watts
MC12A — 200 watts

Half-Space Reference Efficiency

MC8A — 1.35%
MC12A — 1.35%

Amplifier Power Requirements, Continuous Average at 8 Ohms, for the Following Average Sound Pressure Levels, Mid-Band, in the Reverberant Field of a Typical Living Room (R=200) with Peaks 10 dB above Average (Long-Term Average Power Capacity not to be exceeded)

Medium Level (85 dB SPL)
MC8A — 1 watt
MC12A — 1 watt

Loud Level (95 dB SPL)
MC8A — 10 watts
MC12A — 10 watts

Very Loud Level (105 dB SPL)
MC8A — 100 watts
MC12A — 100 watts

Maximum Level

MC8A — 120 watts (106 dB)
MC12A — 200 watts (108 dB)

Impedance

Nominal
MC8A — 8 ohms
MC12A — 8 ohms

Minimum
MC8A — 7.5 ohms
MC12A — 8 ohms

Thiele-Small Driver Parameters, Nominal (see Special Note on Low-Frequency Performance section)

f_s
Free-Air Resonance Frequency
MC8A — 75 Hz
MC12A — 50 Hz

Q_{ES}
Electro-Magnetic Q at f_s
MC8A — 0.87
MC12A — 1.2

Q_{MS}
Mechanical Q at f_s
MC8A — 1.95
MC12A — 2.2

Q_{TS}
Total Q at f_s $\left[\frac{Q_{ES}}{Q_{ES} + Q_{MS}} \right]$

MC8A — 0.60
MC12A — 0.78

V_{AS}
Volume of Air Having Same Acoustic Compliance as Driver Suspension

MC8A — 1.05 ft³
MC12A — 5.1 ft³

η_D
Half-Space Reference Efficiency
MC8A — 1.35%
MC12A — 1.35%

V_D
Peak Displacement Volume of Diaphragm ($= S_D \times X_{max}$)
MC8A — 1.9 in³
MC12A — 4.7 in³

S_D
Effective Diaphragm Area
MC8A — 30 in²
MC12A — 75 in²

X_{max}
Peak Linear Displacement of Diaphragm

MC8A — 0.063 in
MC12A — 0.063 in

$P_{E(max)}$
Thermally Limited Maximum Input Power

MC8A — 12 watts
MC12A — 20 watts

R_E
DC Resistance of Voice Coil
MC8A — 6.5 ohms
MC12A — 7.5 ohms

Cone Diameter, Nominal
MC8A — 8 in
MC12A — 12 in

Voice Coil Diameter
MC8A — 1 in
MC12A — 2 in

Magnet Weight
MC8A — 10 oz
MC12A — 13 oz

Magnet Material
MC8A — ceramic
MC12A — ceramic

Dimensions
Overall Diameter
MC8A — 8-1/4 in
MC12A — 12-1/4 in

Overall Depth
MC8A — 3-3/16 in
MC12A — 3-1/2 in

Mounting Bolt Circle
MC8A — 7-5/8 in
MC12A — 11-9/16 in

Mounting Hole Diameter, Four Evenly Spaced Holes
MC8A — 7/32 in
MC12A — 0.28 in

Baffle Opening Diameter (Note: Frame does not permit front mounting.)
MC8A — 7 in
MC12A — 11 in

Net Weight
MC8A — 4 lb, 2 oz
MC12A — 5 lb, 7 oz

ELECTRO-VOICE COMPONENT SPEAKERS

Electro-Voice component speakers have traditionally provided the hobbyist and professional with the flexibility of custom installation as well as the opportunity for simple "building-block" system expansion and improvement. A comprehensive group of cone speakers, mid-frequency horns and drivers, horn tweeters, crossovers, and accessories is available. Additionally, all Electro-Voice component speakers offer conversion efficiencies substantially higher (3 to 8 dB) than typical "bookshelf" home speaker systems. This high efficiency is essential for most professional audio applications. In the home it permits accurate reproduction of the high sound levels of live music or, for more normal listening levels, the use of amazingly small amplifiers for satisfactory reproduction.

Electro-Voice cone speakers have now been thoroughly revised to reflect the latest knowledge of rational, optimized low-frequency speaker enclosure design. The result is a combination of extended low-distortion bass response, high efficiency, and modest cabinet size simply not available in other component speakers.

PRODUCT DESCRIPTION

The Michigan[®] MC8A and MC12A speakers are designed to provide full-range high-fidelity reproduction at modest cost. Both speakers are appropriate for home music systems and the smaller MC8A may be used commercially in high-quality ceiling mounted sound systems.

High-frequency output is enhanced by a centrally mounted free-edge cone whose dimensions and mass have been carefully chosen for maximum performance improvement. The free-edge cone is small and light so it is able to respond to the extremely rapid high-frequency motions of the voice coil which the large main cone cannot follow. The MC8A and MC12A have die-cast frames which offer long-term stability not found in stamped-frame speakers. Also, the MC8A's frame is drilled to accept Electro-Voice TM5, TR5, and TR15 line-matching transformers.

The characteristics of both speakers have been carefully developed to work well in vented (bass reflex) enclosures of small or reasonable size. In the recommended 2.4 cubic feet vented enclosure

the MC8A provides essentially flat response to 50 Hz with usable output down to 37 Hertz. The larger MC12A, in its recommended 6 cubic feet enclosure, has essentially flat response to 40 Hz with usable output to below 30 Hz. In addition, the MC8A may be housed in the small sealed ceiling-mounted boxes used in commercial applications.

RECOMMENDED ENCLOSURES

The MC8A and MC12A have been designed for mounting in vented boxes appropriate to the speaker characteristics. The use of a vented box with its tuned feature complements the performance of the speaker and provides maximum low-frequency performance consistent with size and speaker parameters. A vented box not only increases the low-frequency power output but also reduces distortion for a given level.

The MC8A may also be used in the small sealed enclosures found in ceiling-mounted distributed speaker systems. When used in this way low-frequency performance is considerably reduced but is usually adequate for commercial applications.

In the listing below we have attempted to choose a typical vented box size that best complements the MC8A and MC12A. Other vented box sizes and tunings are quite feasible and may give performance more suitable for a particular application. Two small sealed enclosures for the MC8A are also shown. For further information refer to the Special Note on Low-Frequency Performance section of this sheet and ask for a copy of Bulletin 10B.

Explanation of Symbols:

- V_B Net internal enclosure volume, not including volume displaced by bracing, port, or speaker. Variations of $\pm 10\%$ are acceptable.
- f_B Helmholtz resonance frequency of box-vent combination.
- f_3 Frequency at which the small signal (normal listening levels) acoustic power vs. frequency is down 3 dB relative to the mid-band output.
- f_{10} Frequency at which the small signal (normal listening levels) acoustic power vs. frequency is down 10 dB relative to the mid-band output.
- f_{LL} Usable low-frequency limit, the frequency at which the large-signal maximum acoustic power output vs. frequency is 10 dB below the maximum mid-band output (due to either thermal or displacement limitations).

Dimensions for the two recommended vented enclosures are shown below:

V_B	MC8A — 2.4 ft ³ MC12A — 6 ft ³
Inside Depth (D)	MC8A — 13 in MC12A — 17-5/16 in
Inside Width (W)	MC8A — 16-1/4 in MC12A — 21-13/16 in
Inside Height (H)	MC8A — 20-3/4 in MC12A — 27-1/2 in
Port Area (XY)	MC8A — 12 in ² MC12A — 16 in ²
Port Depth (L)	MC8A — 2-3/4 in MC12A — 4-3/4 in

Unit	Enclosure Type	V_B (ft ³)	f_B (Hz)	f_3 (Hz)	f_{10} (Hz)	f_{LL} (Hz)
MC8A	Sealed	.25	0	120	88	88
MC8A	Sealed	1	0	92	58	80
MC8A	Vented	2.4	50	50	37	43
MC12A	Vented	6	40	40	27	34

An outline drawing of a typical enclosure is shown below.

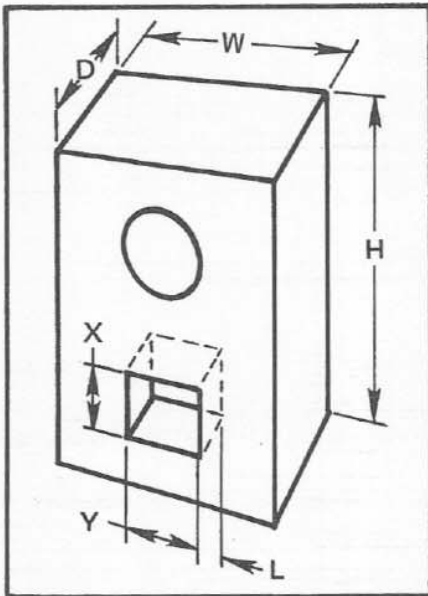

ENCLOSURE CONSTRUCTION

Speaker enclosures should be constructed of rigid materials such as void-free plywood or particle board. In general, 3/4-inch thick material is most satisfactory, although smaller enclosures (approximately 2 cubic feet and under) may be successfully constructed of 5/8-inch material. It is mandatory that the joints between the pieces of wood be strong and well sealed. Simple butt joints secured with wood screws or nails and white glue are very satisfactory. Removable panels should be secured with wood screws and weather stripping tape. For joints longer than about 3 feet, internal glue blocks may be appropriate. In the largest boxes—greater than about 6 cubic feet—bracing is usually required for the largest expanses of wood to prevent sympathetic vibrations from affecting overall system performance. Proper bracing technique splits a rectangular panel into two equal rectangles with the brace placed along the panel's longest dimension. Good bracing materials are 2 X 2 dimension lumber or 4-inch widths of 3/4-inch plywood, placed on edge. Three mutually adjacent inside surfaces of the enclosure (top, one side and rear) should be lined with a one to two inch thickness of glass wool or similar acoustic absorptive material to prevent internal reflections from affecting mid-frequency performance. No absorptive material should be placed over or within the port.

The location of the speaker on the mounting baffle is relatively unimportant but close-to-ear-level mounting will provide best mid- and high-frequency performance in the listening room. The enclosure's height, width, and depth may be changed as long as (1) the internal volume remains the same ($\pm 10\%$) and (2) extreme differences between any two dimensions are avoided. The required port area can be obtained by any convenient combination of width (Y) and height (X) as long as its long dimension is no more than five times the short dimension. The port is normally located on the front baffle board but may also be on any other box surface that has free access to the listening room. For most accurate box tuning the port should be no closer than several inches from the nearest adjacent enclosure wall. The port's proximity to the speaker is unimportant.

SPEAKER INSTALLATION AND HOOKUP

The MC8A and MC12A are designed for installation on the inside surface of the mounting baffle. As with all quality speakers care should be taken in mounting if best results are to be obtained. Drill four mounting holes and cut the mounting baffle opening in accordance with the dimensions given in the Specifications section. To mount the speaker, four carriage bolts with nuts and washers may be used. The MC8A frame will accommodate a 3/16-20 bolt and the MC12A will accommodate a 1/4-20 bolt. Wood screws are not recommended. Secure the speaker to the baffle board just tightly enough to compress the speaker gasket. Excessive tightening is not necessary since the compressible gasket will form a satisfactory seal with only nominal pressure.

To avoid any significant amplifier power loss in the speaker lines and undesirable change in low-frequency response, wire size must be properly chosen. 18 gauge stranded wire (commonly called lamp or "zip" cord) is satisfactory for lengths up to 38 feet, limiting the loss in sound pressure level to an insignificant 0.5 dB. If longer speaker lines are required, use progressively larger wire sizes: 16 gauge to 60 feet, 14 gauge to 96 feet, and 12 gauge to 150 feet. These lengths assume the 8-ohm impedance of one speaker.

Two speakers in parallel have an impedance of 4 ohms, so if connected to the end of a single speaker line the lengths listed above must be halved. If it is desired to run the speaker line under a carpet TV twin lead may be used for short distances.

Transformer Installation (MC8A)

For constant-voltage distribution systems an Electro-Voice TM5, TR5, or TR15 line-matching transformer may be directly mounted on the MC8A frame using the holes provided with two 6-32 x 1/4 self-tapping screws.

PERFORMANCE IMPROVEMENT WITH BUILDING BLOCK KITS

While both the MC8A and MC12A will provide quite adequate sound reproduction under most circumstances, an improvement in performance can easily be realized by adding a tweeter and mid-frequency speaker.

The tweeter will provide the most dramatic improvement and should be added first through the use of an HF1 High-Frequency Building Block Kit. The HF1 includes a TW35 horn tweeter, CR35 crossover/level control, wiring harness, and mounting hardware. In addition to extending the high-frequency response beyond the limits of normal audibility, the HF1 provides more precise definition of high-frequency wave forms and much improved high-frequency dispersion in the listening area. The improved dispersion makes it possible for the listener to move considerably off the central axis while experiencing very little change in sound quality.

The MF1 Mid-Frequency Building Block Kit, comprised of an MR10 horn/driver, CR10 crossover/level control, wiring harness, and mounting hardware, provides additional improvement in performance after installation of the HF1. The MF1 further reduces the frequency range which must be reproduced by the cone speaker, reducing harmonic and intermodulation distortion in the system. The MR10's diffraction horn improves dispersion in the listening area in addition to increasing efficiency. The improved mid-frequency performance provided by the MF1 is especially important because instrument and voice harmonics which determine the character of the sound are found in this frequency range.

SPECIAL NOTE ON LOW-FREQUENCY PERFORMANCE

The recommended enclosures and associated performance specifications displayed earlier were determined in accordance with the definitive analysis of A. N. Thiele, R. H. Small, and others. The performance of speakers in sealed enclosures (including acoustic suspension types) has been well understood for some time. In contrast, vented systems have been designed using not much more than cut-and-try methods with little real engineering know-how. However, the above mentioned analysis has changed this picture completely.

Thiele showed the similarity between a speaker in an enclosure and an electrical high-pass filter circuit. Application of well known filter analysis techniques led to quite accurate performance calculations for any speaker mounted in any vented or sealed cabinet. Moreover, it was shown that a properly executed speaker/vented-enclosure combination held clear-cut advantages over a sealed system in the areas of efficiency, box size, low-frequency limit, and distortion. These results make the choices of box size, low-frequency limit, efficiency, power-handling capacity, and maximum acoustic power output relatively easy to make. In fact, Thiele even presented in tabular form quite a number of possible vented box choices having optimum performance characteristics (see A. N. Thiele, "Loudspeakers in Vented Boxes: Part I" *J. Audio Eng. Soc.*, Vol. 19, May 1971, p. 388)

By applying the work of Thiele and Small, Electro-Voice engineers developed a computer program which easily, quickly, and accurately predicts the performance of any speaker-box system in the frequency range where the diaphragm is acting as a simple piston. The upper limit for this operation is usually the frequency at which the diameter of the diaphragm becomes a large fraction of a wavelength.

The Thiele-Small Driver Parameters shown in the Specifications section include the speaker characteristics required by the computer program to develop the small and large signal performance of a given speaker and enclosure combination.

For more information on this subject, ask for Bulletin 10B. It includes additional vented enclosure recommendations for Electro-Voice component speakers and a detailed bibliography of the work of Thiele, Small, and others. Also, where the Thiele-Small Driver Parameters are known, Bulletin 10B shows how to choose the size and tuning of a vented enclosure and how to determine the low-frequency response of vented and sealed speaker systems using scientific pocket calculators.

WARRANTY (Limited) —

Electro-Voice High Fidelity Speakers and Accessories are guaranteed for five years from date of original purchase against malfunction due to defects in workmanship and materials. If such malfunction occurs, unit will be repaired or replaced (at our option) without charge for materials or labor if delivered prepaid to the proper Electro-Voice service facility. Unit will be returned prepaid. Warranty does not cover finish or appearance items or malfunction due to abuse or operation at other than specified conditions. Repair by other than Electro-Voice or its authorized service agencies will void this warranty.

For correct shipping address, instructions on return of Electro-Voice products for repair, and locations of authorized service agencies, please write: Service Department, Electro-Voice, Inc., 600 Cecil Street, Buchanan, Michigan 49107 (Phone: 616/695-6831).

Electro-Voice also maintains complete facilities for non-warranty service of E-V products.

Specifications subject to change without notice.



ELECTRO-VOICE, INC., 600 Cecil Street, Buchanan, Michigan 49107

MANUFACTURING PLANTS AT ■ BUCHANAN, MI ■ NEWPORT, TN ■ SEVIERVILLE, TN ■ REDMOND, WA ■ GANANOQUE, ONT.
©Electro-Voice, Inc. 1987 ■ Litho In U.S.A. Part Number 53013-613

a MARK IV company

Free Manuals Download Website

<http://myh66.com>

<http://usermanuals.us>

<http://www.somanuals.com>

<http://www.4manuals.cc>

<http://www.manual-lib.com>

<http://www.404manual.com>

<http://www.luxmanual.com>

<http://aubethermostatmanual.com>

Golf course search by state

<http://golfingnear.com>

Email search by domain

<http://emailbydomain.com>

Auto manuals search

<http://auto.somanuals.com>

TV manuals search

<http://tv.somanuals.com>