



EVI-12, EVI-15 and EVI-28
Loudspeaker Systems

Applications Guide

Welcome to the world of Vari Intense® horn technology from Electro-Voice. This Applications Guide is not intended as a “very intense” description of installation procedures, but more as a partial description of applications and a discussion with the designer to help you understand this revolutionary technology and use the Electro-Voice Vari Intense® systems to install better-sounding systems and significantly reduce time and material costs.

In a nutshell, here are the major advantages of the new EVI systems:

- ***Rectangular coverage pattern.***

Traditional horns deliver an elliptical pattern to the floor. VI horns deliver a rectangular pattern, which helps to fill in the corners of the room. No more costly delay lines or cheap seats!!

- ***Even SPL front-to-back.***

The unique, patented throat and flare structure of the VI horn delivers a 6-10 dB hotter signal to the rear of the room, eliminating ear-strain at the back of the seating area and painful ears at the front.

- ***Greater Intelligibility.***

VI horns deliver sound to fill only the floorplan, providing uniform direct-field SPL and an order of magnitude less energy into the reverberant field. This provides an increase in mid- to high-frequency intelligibility of 6 dB in most applications.

- ***One horn replaces two.***

With VI technology we've eliminated the destructive interference which occurs between long- and short-throw horns. We've also eliminated the cost of a properly designed two-horn system which must include another power amplifier channel for good power control and impedance matching.

- ***Labor savings in the box.***

With structural rigging from the factory, these systems will fly more conveniently and in less time than many competitive products. In addition, less time is spent on the aiming and repositioning that is required with traditional long-throw/short-throw horn combinations. This will save you additional money.

Installation procedures for any conventional loudspeaker are fairly well-defined and easy to understand: find an appropriate hanging height and position that affords a clear path to the listening area (such as above the center of a stage or above the lectern in a church), and aim the loudspeaker towards the center or just to the rear of center of the room. With this method you hope to cover the majority of the room with fairly consistent sound, but the mid and high frequencies never seem to fill perfectly. It is frequently aimed a little too far back and there is a large amount of slap echo, or the front row is too loud, the back row too soft and the front and back row corners sound muted due to a lack of high-frequency energy. Other solutions to filling the room have been suggested and implemented, including a dual-horn format (one long throw and one short throw). This method works fairly well, but encounters several problems: the added expense of another horn/driver combination; the vastly increased time to physically install and then tune the level and aiming of **two** horns; the inevitable destructive interference patterns throughout the listening area; the expense of another amplifier channel to achieve correct impedance matching; and the need for a very aesthetically clean installation, with no odd-looking (to the customer) dangling horns. Another solution is to have a horn that is variable angle, in order to throw a narrow pattern to the back of the room. The problem with this concept is that this doesn't take into account the drop in SPL between the near throw (about 25 feet) and the far throw (about 70 feet), so the high frequencies are about 10 dB down in the back of the room. To solve all of these problems, the Vari Intense® horns were invented, yet another innovation in the long tradition of Electro-Voice. When properly aimed, the Vari Intense® horns can provide extremely even SPL throughout an entire room, filling in the corners without pushing too much energy at the back wall, thus avoiding slap echo. The rules of fixed installation have just changed...

The Electro-Voice EVI-12, EVI-15 and EVI-28 enclosures are the first in a new generation of problem-solving systems. The new systems are designed as a package, with easy mounting, refinishing ability, lightweight, compact and unobtrusive size and shape and the classic musical sound that Electro-Voice is known for. The new small-format VI horn maintains consistent directional control down to 2,000 Hz. In the EVI-12 and EVI-15 the VI horn is optimally crossed over to an specially

angled woofer. Note: the 12-in. driver in the EVI-12 is at a different angle than the 15-in. driver in the EVI-15, optimizing the floor pattern with the differing directivities of the two drivers. In the EVI-28, the VI horn is crossed over to a pair of vertically-arrayed 8-inch woofers with a proprietary technique that provides delay, amplitude and frequency shading to the two woofers.

The EVI-12, EVI-15 and EVI-28 systems are installed just like any conventional loudspeaker, keeping in mind a few simple guidelines. Let me preface these guidelines with a simple but important comment: the VI systems are extremely versatile and will work in a large variety of applications. They will work well with tall ceilings, short ceilings, rectangular rooms, slightly trapezoidal rooms and a whole host of odd shapes so long as the coverage area is fairly close to rectangular. The larger EVI-12 and EVI-15 have been tested in rooms with 12-foot ceilings and performed very well, although with reduced width of throw. A single EVI-12 was installed in a room 75-foot by 150-foot and an average RT60 of 4.5 in the mid band and performed very well with good intelligibility and a minimum of slap echo. It has been thought in the past that if the floor pattern does not fit the VI horn exactly, then it cannot be used at all. This is not the case, and if it were the case, we could not use standard constant-directivity horns in most applications either. The larger VI systems have an "optimum" room that is approximately twice the height in width and three times the height in length. This is the ideal condition, but the figures and descriptions that follow should give you a good feel for the wide-range capabilities of the systems.

EVI-12 and EVI-15 Installation:

The nominal floorplan that the system will cover with equal SPL is approximately two "units" wide by three "units" long, where the height of the loudspeaker defines the size of the "unit." For example, if the loudspeaker is 18 feet above the floor, it will typically cover a floorplan of about 36 feet wide by 54 feet long. In this typical installation (see Figure 1), the back panel of the loudspeaker is mounted approximately 0.6 units (about 11 feet) back from the first row and has a nominal angle of the top of the enclosure parallel to the floor or slightly tilted back (2 to 3 degrees). For rooms that are much longer than normal, the VI systems are very easy to aim and position to fill the entire length. Experiments in actual listening rooms have shown that with

the same mounting height of 18 feet, but with the front of the enclosure tilted up by approximately 10° (see Figure 2), the total floorplan now encompassed the same 36 foot width, but at least 64 feet in length, an additional 10+ feet of extension. Of course, the front row position has moved back about 5 feet with the change in angle as shown, but this is easy to account for when initially positioning the system (and is exactly what happens if you take a conventional system and change the angle). For rooms that are closer to square, tilting the loudspeaker system down by 15° provides a very clean square pattern. In this case, the offset to the first row is about 0.25 times the height of the system. For example, a tall, square room is about 60 feet wide, and only 65 feet long. Tilting the enclosure down by 15° at a 30 foot mounting height makes a 60 foot wide by 60 foot long pattern. The offset to the first row is 0.25 multiplied by the 30 foot height, or about 7.5 feet forward from the back of the enclosure. Minor adjustments in aiming will make the SPL fill the room very evenly with no loss in tonality in the corners and high overall intelligibility.

By contrast, a typical two-way system with a $60^\circ \times 40^\circ$ CD horn in the same mounting location as Figures 1 and 2 (see Figure 3) produced a floor plan that sounded tonally fairly consistent with a 20- to 24-foot width and 30-foot depth with an offset of nine feet to the front row. On paper, this seems like adequate performance, but in the room it has very noticeable (6 dB or greater) variation in overall level from side to center, and in some aiming cases over 10 dB of variation from front to back as well as a pronounced lemon shape. The sides of the first three to five rows in a church and the last few rows were noticeably muted and much lower in overall level. As mentioned before, a two-horn system can work fairly well, but the physical offsets required for installation inevitably result in some amount of destructive interference throughout the room (see Figure 4). Figure 4 was produced using a $90^\circ \times 40^\circ$ CD horn aimed down by 65° and a $60^\circ \times 40^\circ$ horn aimed down by 30° . The actual physical offsets were used to simulate the floor response in direct-field SPL. The displayed figure agrees very well with the measured response, showing a 14-dB variation at 4kHz in a distance of 3 feet horizontally. Tonal changes as a result of interference pattern change versus frequency were clearly audible in an acoustically well-behaved room, but were overall much less audible than for a single system with a conventional CD horn. Locating drivers

and horns closer together than possible with medium-format horns will produce somewhat better results, but will always result in fairly severe lobing. Polar measurements in 2° increments show the lobing very well, but the smoothing required for translation to the EASE 10° resolution database will eliminate the vast majority of peaks and dips, resulting in what appears to be a fairly smooth simulation. In contrast, the new VI systems have no problems with interference, and maintain very good tonality even far to the sides and to the back, outside the “equal-SPL” pattern area. This effect is due to the precise matching of directivities in the midrange and treble, giving a consistent (although noticeably quieter) frequency response out to nearly 50 feet in width and 65–70 feet in length from the same 18-foot height and 0° aiming angle. This has the advantage of providing a much more uniform power response into the reverberant field, ensuring that the inevitable reflections (minimized by the VI concept) are consistent in tonal quality.

EVI-28 Installation:

The EVI-28 makes use of the same high-frequency horn as the EVI-12 and EVI-15, but includes a pair of high-power, high-efficiency 8” woofers in a very compact package. The system is provided with a 2,000-Hz passive crossover featuring tweeter protection and a proprietary passive equalization circuit that provides frequency-shading, amplitude-shading and time delay to the two woofers. An Acoustic Lens Filter on the grille helps to eliminate spurious lobes and provides a degree of acoustic loading. These features heavily modify the polar response of the two woofers, providing an extremely uniform polar pattern with a shape that matches the VI horn’s unique SPL profile. They also smooth the transition between woofers and the horn to minimize horizontal lobes, providing amazingly even coverage through the crossover point. This extends the VI characteristic down to 500 Hz in an extremely compact enclosure.

The high-frequency horn in the EVI-28 is mounted tilted 15° back relative to the EVI-12 and EVI-15. Along with the polar steering in the woofer’s crossover, this arranges the dispersion for long throws relative to the mounting height. The recommended operational vertical angle is minus 5° from the top surface of the enclosure to minus 45° , defining a maximum used vertical dispersion of 40° . The standard aiming of the system when it

is mounted above a flat floor is with the top of the enclosure parallel to the floor. In this orientation, the system will provide even SPL over a floorplan that is approximately twice as wide as the mounting height, and five times as long. Tilting the enclosure down by approximately 10- to 15° relative to the slope of the floor will produce a floorplan the same as an EVI-12 or EVI-15. At the standard aiming, the 45° nearfield operational angle defines an approximate offset to the first useable row of one-half the height of the speaker system above the listening plane.

In a typical installation, the top surface of the loudspeaker will point slightly above the head height of the furthest targeted seating or standing area. This will ensure the minimum amount of slap echo from the back wall. In an under-balcony situation, the sharp cutoff above the zero degree axis prevents early ceiling reflections from causing interference patterns in the listening area. Since an EVI-28 has a very smooth and rapid drop-off towards directly below the cabinet, you can actually stand right in front of the speaker (see Figure 12) without ear strain or heavy microphone feedback. The remarkable absence of lobes to the rear allows the system to be mounted directly overhead to target a particular area without disturbing the audience below or behind the cabinet.

For example, FIGURE 11 shows a typical under-balcony application that has a floor with an upward slope of 5°. The speaker is mounted 10 feet above the seated head height, so the horizontal width is fixed at approximately 20 feet. The enclosure is tilted back by 5° to provide a 50-foot throw, with the outskirts of the pattern filling in the rear aisle area with tonally accurate but reduced overall SPL. If the under-balcony seating area is only 35 feet deep, then the enclosure should be tilted down by about 10° relative to the floor in order to prevent excess slap echo and preserve intelligibility.

Figure 12 shows a typical small-room application, perfect for a 20-foot by 30-foot boardroom or meeting hall. In this case, the head height is actually defined by a standing height of approximately 6 feet, so the long-throw axis should be very close to horizontal. Then the included 40 degree angle points directly towards the entire listening area, minimizing slap echo while retaining a full width, high intelligibility and even SPL throughout the listening area.

Q vs. Intelligibility:

The “Q” of a system is a good measure of the system’s directivity, and in some ways a good measure of whether the system’s in-room response will be consistent across the frequency range. A typical 12-inch two-way system with a 60° x 40° horn will maintain a fairly constant Q from 16-30 or 12-15 dB (normally about 26, or 14dB) from 3,000–20,000 Hz, and a 90° x 40° a Q of 13-15 (11-12dB). Very-high-directivity horns such as a 40° x 20° will have an average Q in the range of 45 (16.5 dB), and very-low-directivity horns like a 120° x 40° will have a Q of 7-9 (8.5-9.5 dB). It is generally thought that a high-directivity horn will have greater intelligibility across a given pattern area than a lower-Q device, and this is true in most cases. Also true in most cases is that a standard horn pattern will not fill a typical floorplan, thus drastically reducing the effectiveness of the higher Q. In direct comparison, the VI horn pattern will fill a majority of floorplans with direct-field sound rather than relying on reverberant energy to “fill in the gaps” in overall sound quality and quantity. The Q of the VI systems are very consistent from 1,000–20,000 Hz, with a range of 10-18 (10-12.5 dB) and an average Q of 13.5 (11.5dB) or consistent with the overall directivity of a 90° x 40° system. This might lead you to believe that the VI systems are “low-Q” and inappropriate for highly reverberant rooms, but the plots of the direct-field SPL and its accompanying C50 ratio show a significant advantage to the VI system over a conventional 60° x 40° system. As we all know, high Q only helps when the polar response fits into the listening space as closely as possible. Please keep this in mind when using Q as a benchmark for system intelligibility. For those unfamiliar with the term C50, it is a measure of intelligibility defined by the acoustic power in the room in the first 50 msec divided by the power from 50 msec to infinity, expressed in dB. The minimum recommended level of intelligibility is 0 dB, roughly equivalent to 10% Alcons.

A Note on Simulation Software:

Data files for AcoustaCADD™ and EASE™ are available from Electro-Voice’s BBS, by special request or on Electro-Voice’s Website (<http://www.electrovoice.com>). The figures have all been produced in EASE, but with the current 10° resolution of the software, much of the 2° resolution data we collect has been lost in the required averaging translation to the 10-degree format. The net result

is that 3dB of long-throw SPL and 1.5-2dB of side-fill level has been lost. A higher resolution data file is needed to provide a “real world realistic” simulation. Figure 5 shows the raw 2° polar data with the averaged 10° data superimposed. Also shown are floorplans from our 2° modeler, DCSO, the 5-degree AcoustaCADD and 10-degree EASE. By comparing the 2°, 5° and 10° resolution you can easily see the apparent loss in direct-field SPL. This loss shows up as a series of “steps” along the length of the room and an artificially narrowed throw with less SPL in the corners than would be achieved in a real-world installation. Please keep this in mind when using simulation software.

Hanging EVI Systems:

For the EVI-12 and EVI-15 the physical mounting of the systems have been designed to be as easy as possible, with two simple options available. By far, the easiest solution is to use the optional sturdy, cost effective EVI-12MB or EVI-15MB U-Brackets that mount to the 3/8-16 T-nut locations on the sides of the enclosure. The supplied forged-shoulder eyebolt must be used in the t-nut location on the lower back side of the system as a pull-up point (see figure 13). With this arrangement, the U-Bracket holds approximately 80% of the weight of the system, and the pull-up point provides a convenient method of adjusting the aiming angle. The U-Brackets have easy-to-install bolt patterns and include three sets of OmniMount 100 bolt patterns. For most applications, this will be the preferred methodology as it is fast, aesthetically pleasing, flexible and inexpensive. However, this method will not work in all applications, so we have included a second set of T-nut locations on the top of the enclosure so that the hanging cables can be completely out of view from below (see Figure 14). The front pair of hanging points should carry approximately 50 lbs of the enclosure’s weight, with the required pull-up point taking the balance of the weight (about 5 lb). The T-nut locations are intended to be used only with forged shoulder eyebolts with a minimum tensile strength of 350 kg (770 lb). The inexpensive EBK-1 kit includes three eyebolts, especially helpful when access to quality forged shoulder eyebolts is limited. Please keep in mind that the center of gravity is designed to be behind the main hanging points. This means that the back of the system will rotate as much as 50 degrees down, allowing easy aiming adjustment to virtually any angle.

Please note: the pull-up location on the lower section of the back panel of the enclosure **MUST** be used to hang the system in order to provide a safe, stable mounting system. The pull-up point provides an additive safety, as it is capable of holding the speaker system with a safety factor of at least 5:1 in the unlikely event of a failure in the main load-bearing system.

For the EVI-28, the mounting holes are positioned very near the center of gravity for easy aiming. The U-brackets may be rotated all the way around the back of the enclosure, allowing easy installation and aiming. The maximum vertical angle that may be reached is approximately 35°, less if the loudspeaker is mounted flush against a ceiling. In this case, the enclosure may be rotated upwards by at least 15°, more than sufficient for nearly any application (see Figure 15). The brackets are supplied with friction washers that will prevent the enclosure from rotating over time, but to be absolutely certain, the installer should use a set screw in the threaded hole to fix the enclosure permanently in position.

The described hanging methods are rated for suspending only one speaker (with a minimum of an 8:1 safety factor). **Hanging any additional weight from the speaker will exceed its strength rating and create an unsafe condition.**

A Sampling of EVI Applications:

Now that the technical details are covered, here are a few ideas on applications that the EVI systems will cover with far more uniform sound and lower overall cost than any conventional enclosure. The first and most obvious application is in a church or some other well-defined space that has a fairly tall ceiling, and proportions of roughly 2 x 3 (see Figure 1). In this application, the EVI systems can easily replace a central cluster or distributed system with a single low-cost enclosure and still maintain a more uniform sound distribution. Figure 2 shows a similar room, but with a somewhat longer throw, where the EVI systems also perform very well. Many auditoriums and theatres are much wider than a typical set of church pews, so Figure 6 shows a fairly standard auditorium floor plan and possible mounting locations. Any interference between the systems will be concentrated in the center aisle, where sound quality is not as critical. The EVI-12, EVI-15 and EVI-28 systems are also ideal for replacing distributed arrays, providing much more uniform coverage at a lower cost. See Figure 7 for

an idea on how the same auditorium floor plan could be easily covered in a surround-style arrangement with just two EVI systems per side rather than four distributed arrays. Although not providing the highest intelligibility or smoothest response, it is applicable to cinemas and some musical preferences. This has the advantages of cutting installation time, amplifier channels, additional delay lines and at the same time providing superior coverage.

A gymnasium is another perfect application for the EVI systems, covering each grandstand from a pair of centrally located EVI systems (see Figure 8). In addition, you can cover the entire gymnasium from either a single lengthwise-oriented system or with a pair of widthwise-spaced systems with lower-SPL coverage on the floor of the gymnasium than in the stands, so the players are not disturbed by announcements (see Figure 9).

When the EVI-12 and EVI-15 systems are tilted up approximately 15°, their coverage pattern lengthens to match a level EVI-28 at 5 times the height. In such cases the systems work very well to

replace a distributed system along a very long, fairly wide corridor where very high SPLs are not required on a continuous basis (such as an airport concourse with 15 to 20 foot ceilings, where a speaker would be placed about every 75 feet). See Figure 10 for approximate mounting locations and floorplan coverage.

These are but a few of the widely varied applications where the new EVI-12, EVI-15 and EVI-28 systems will easily outperform a conventional system. The extremely uniform coverage of the systems are fairly insensitive to placement, require only a few simple calculations to find the best mounting location, and the aiming angle is no more or less sensitive than a conventional loudspeaker. This makes installation nearly foolproof. Even installation in non-optimal conditions will produce remarkably even coverage and high intelligibility.

As questions arise, you may feel free to contact us at 800/234-6831, or FAX at 616/695-1304.

NOTE: All figures are direct-field SPL and C50 produced in EASE with interference turned on when applicable. All plots depict the intended listening areas only, and do not include the “offset distance” to the first row. For example, the first set of plots on figure 3 depict the same 54’ x 36’ area as figure 1. See notes on simulation software.

Figure 1

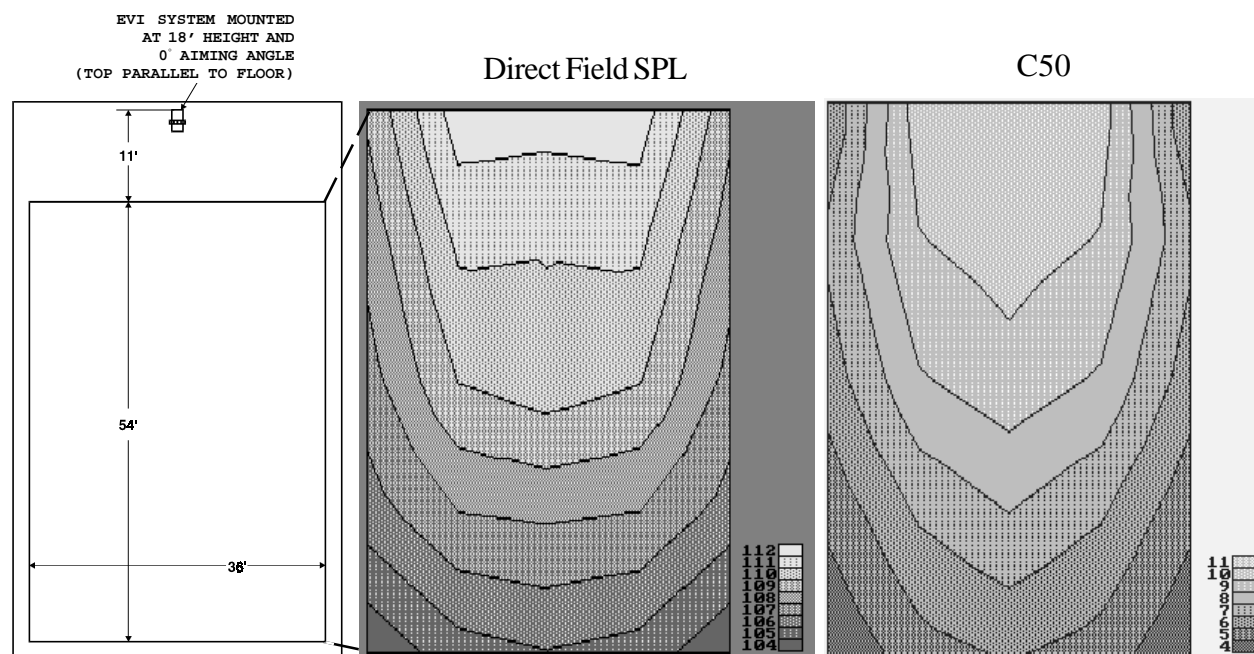

Figure 2

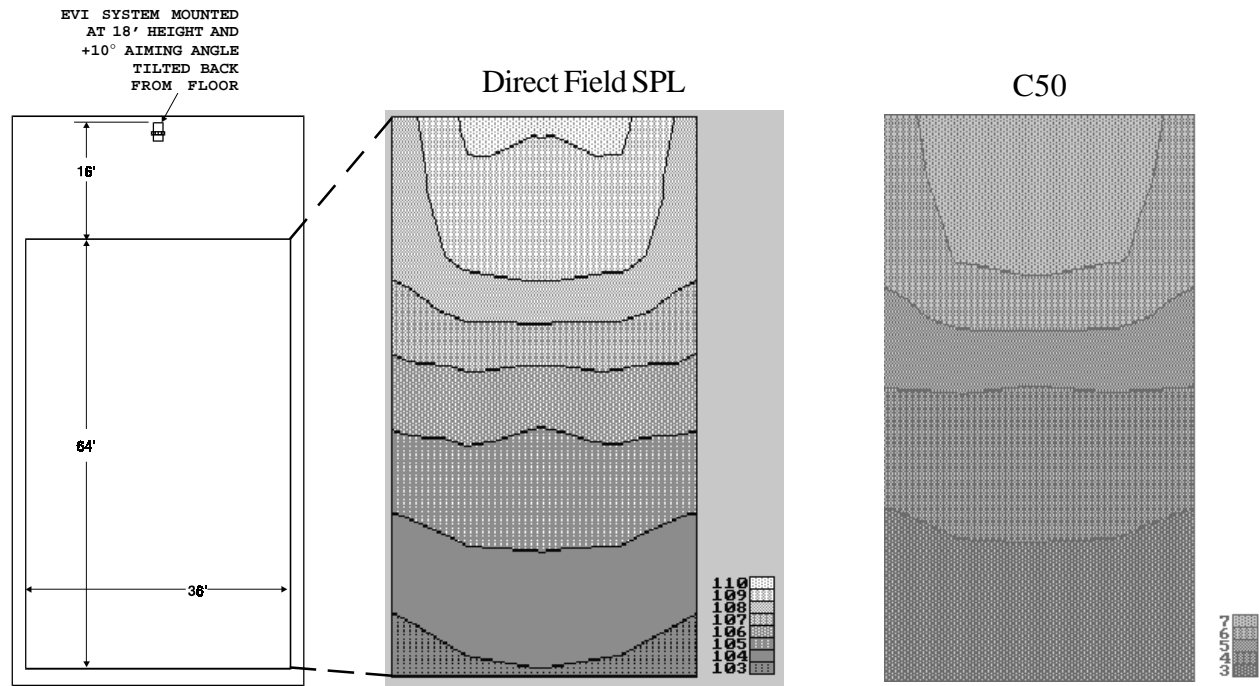

Figure 3

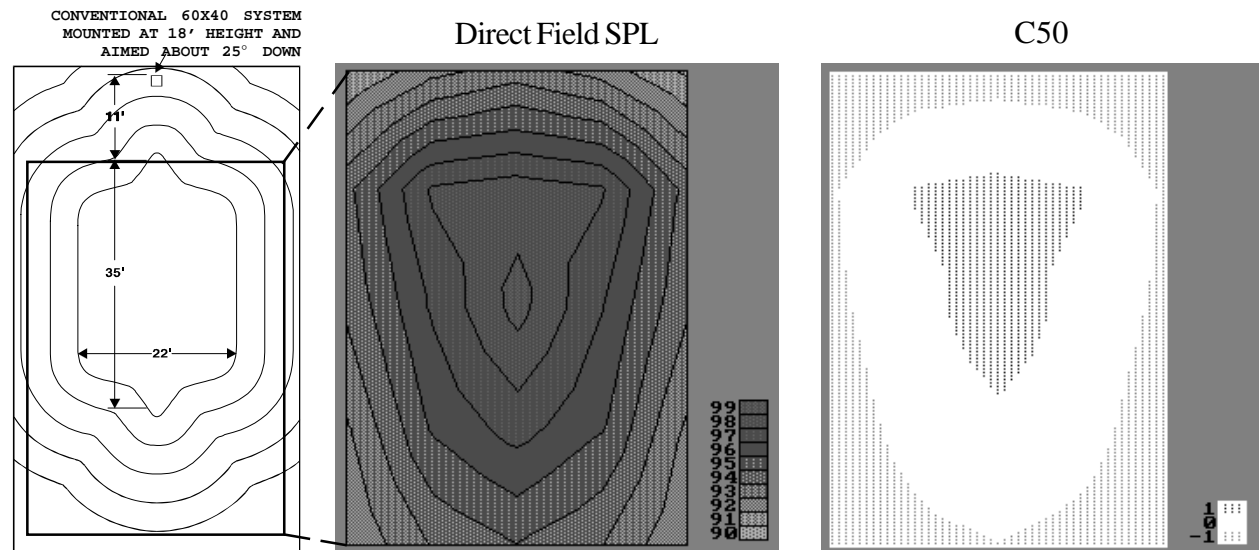
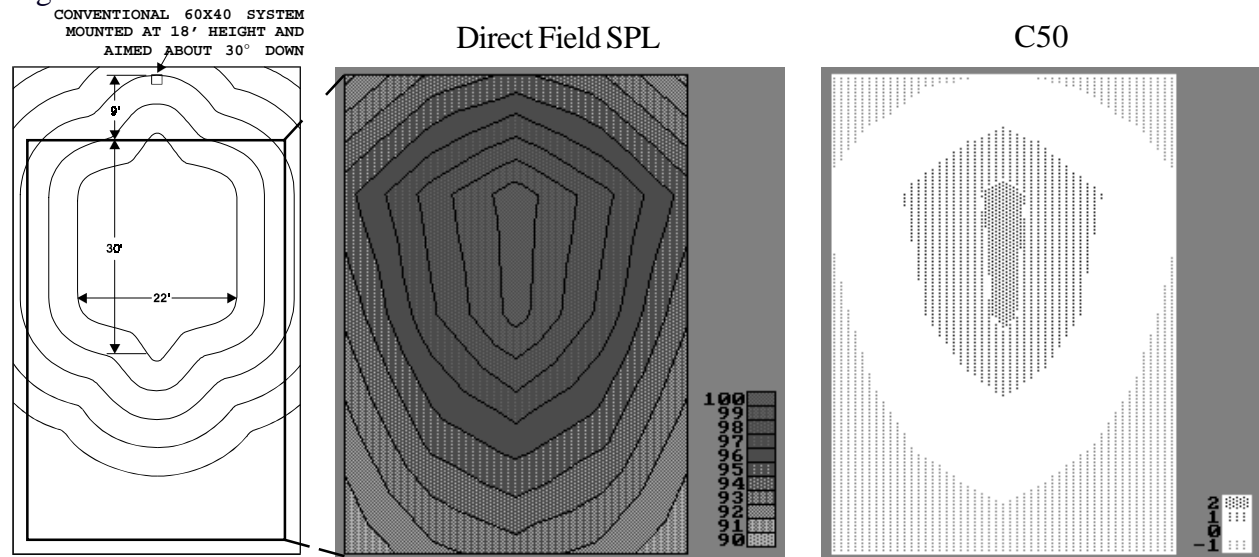

Figure 4 Direct Field SPL

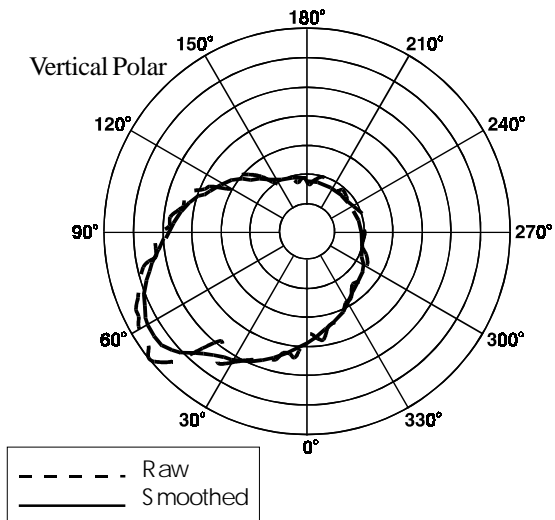
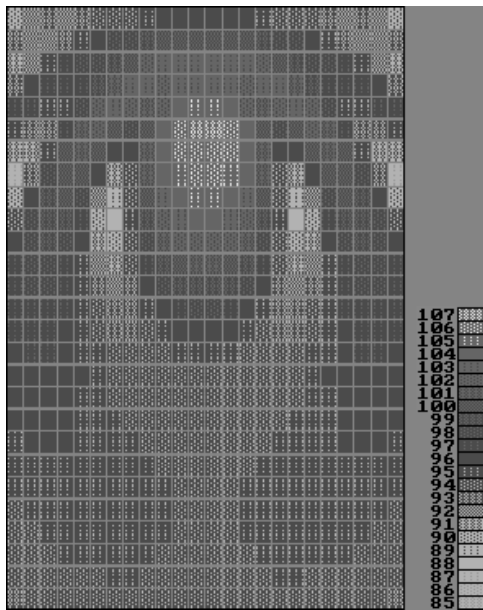
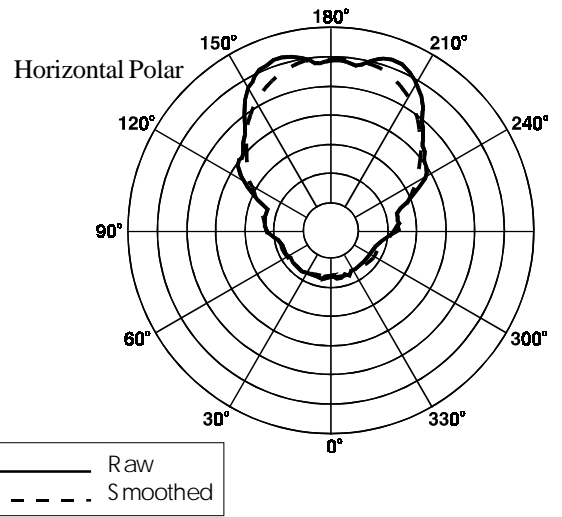
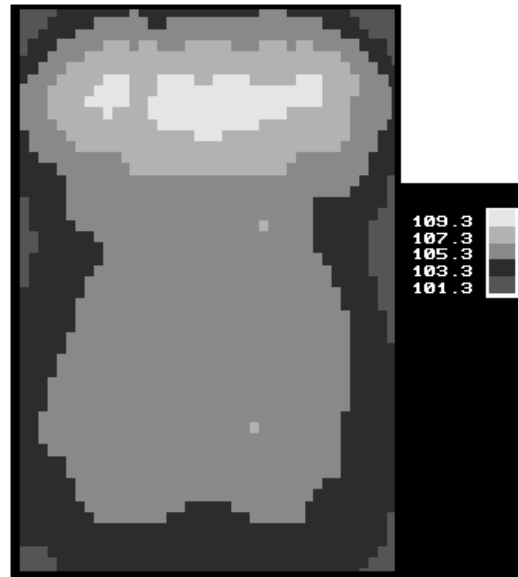

Figure 5



AcoustaCADD™ Direct Field SPL



EASE™ Direct Field SPL

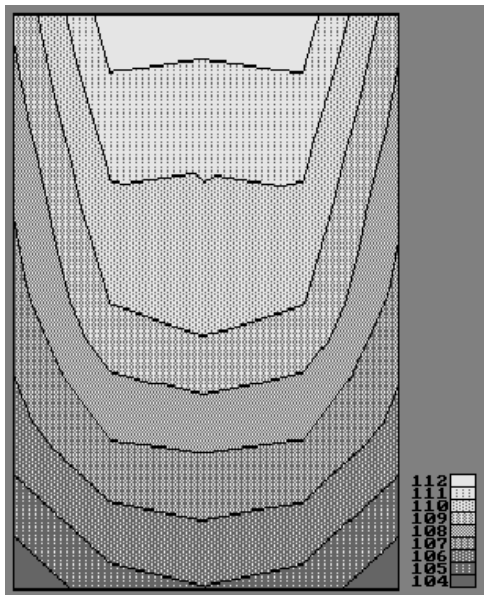

DCSO Direct Field SPL

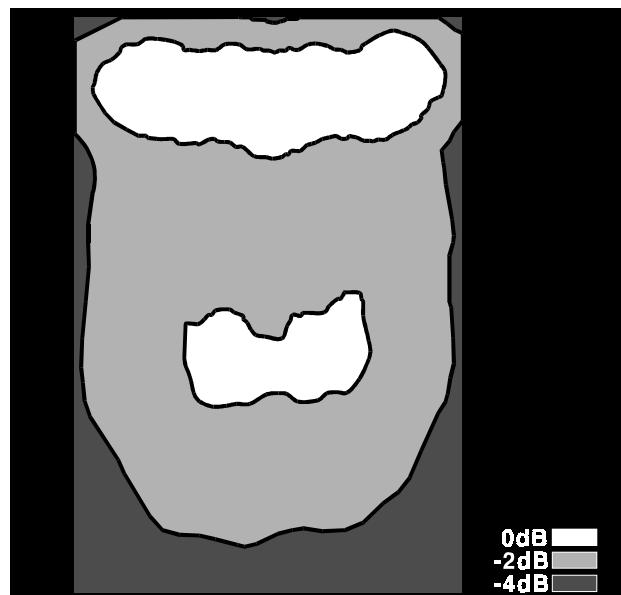
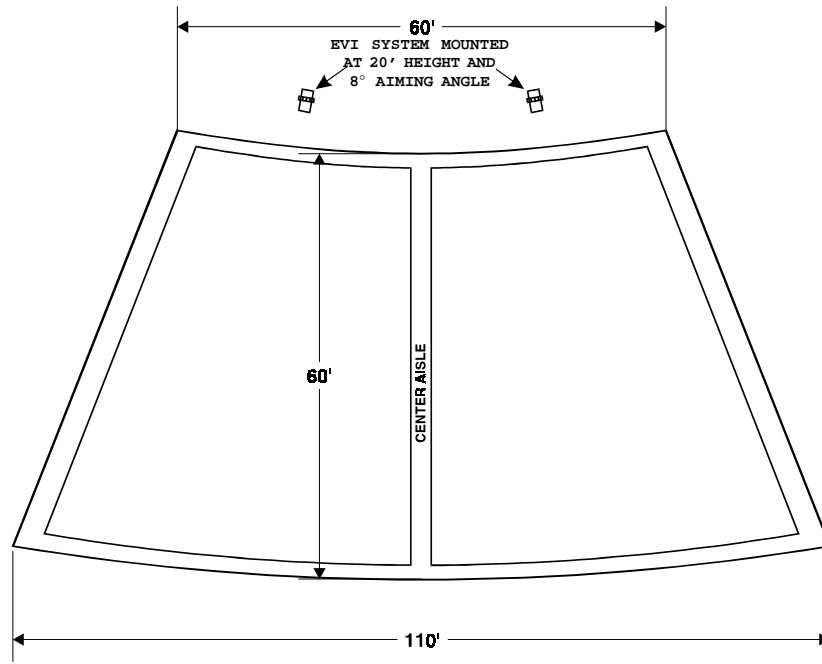
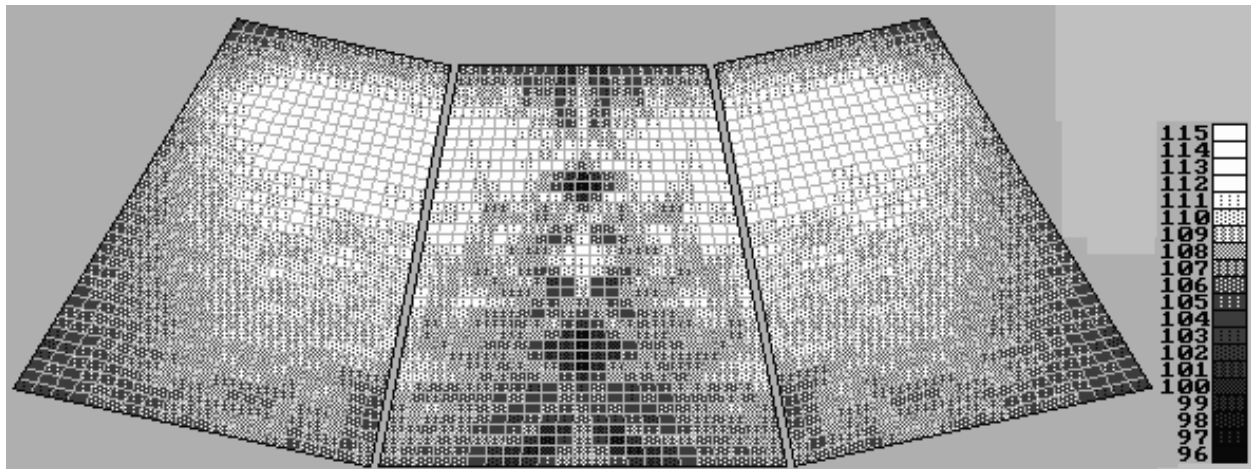

Figure 6



Direct Field SPL



C50

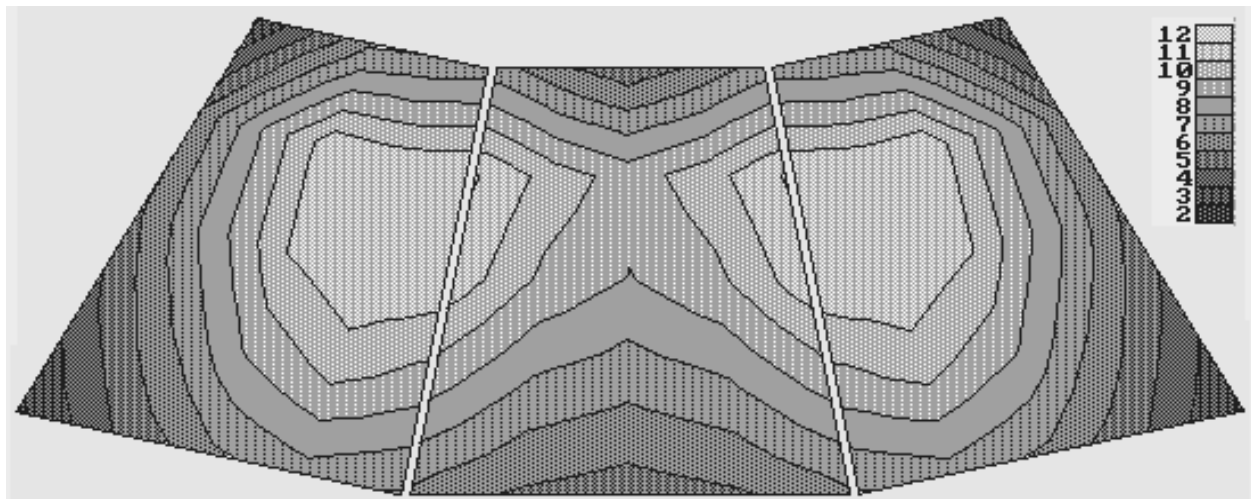
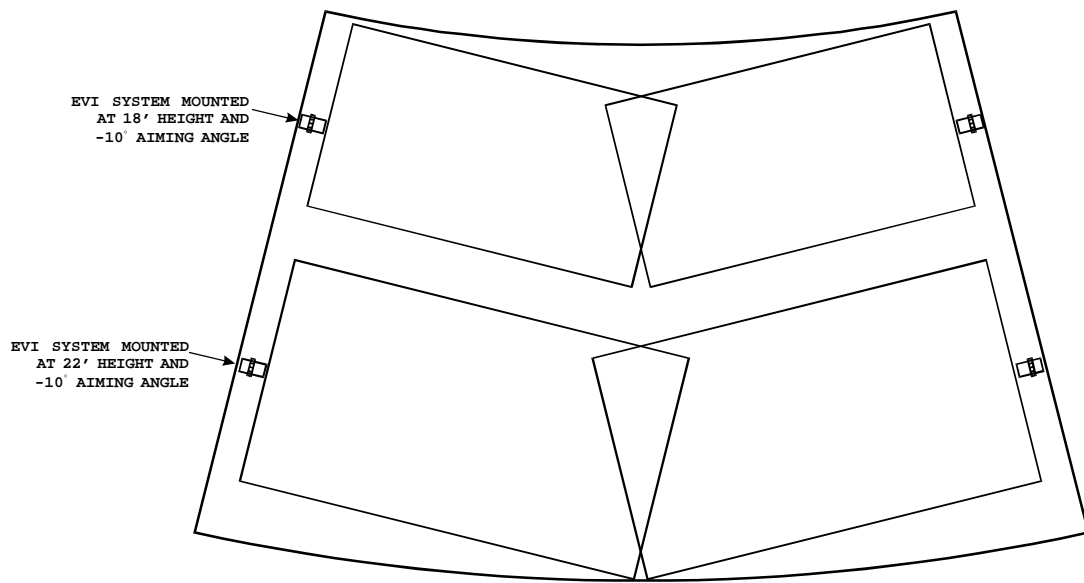
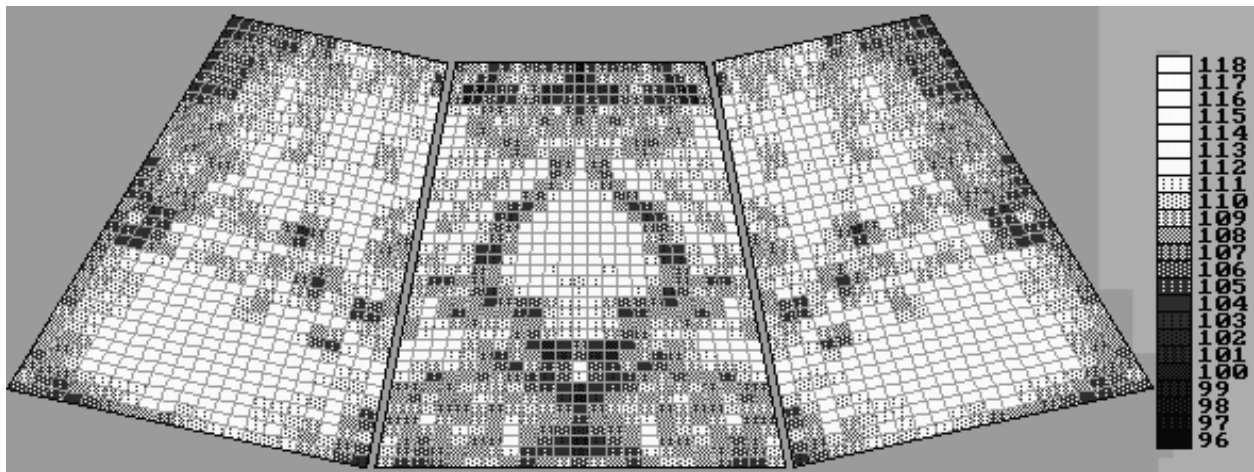

Figure 7



Direct Field SPL



C50

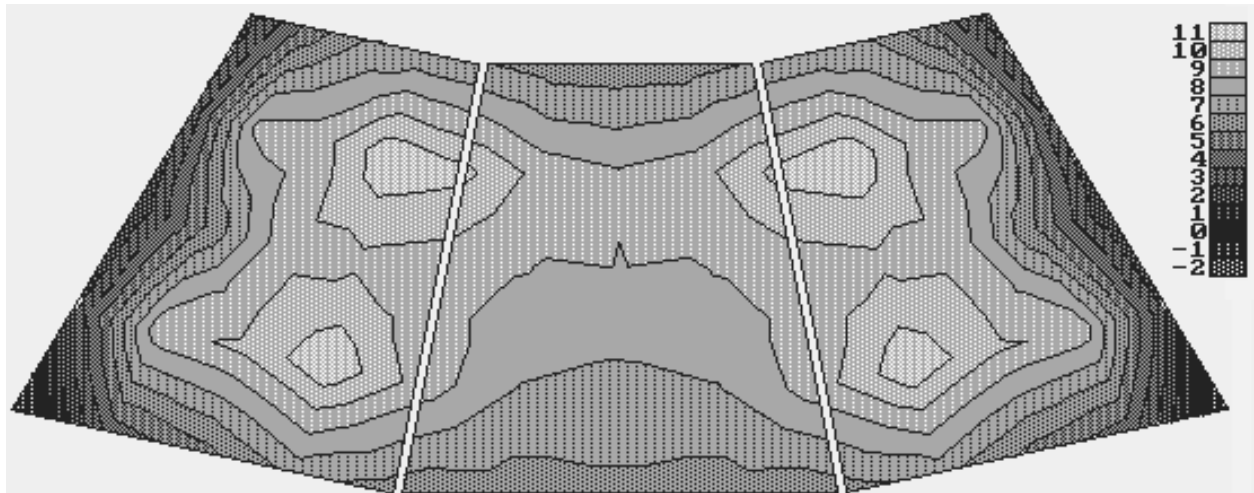
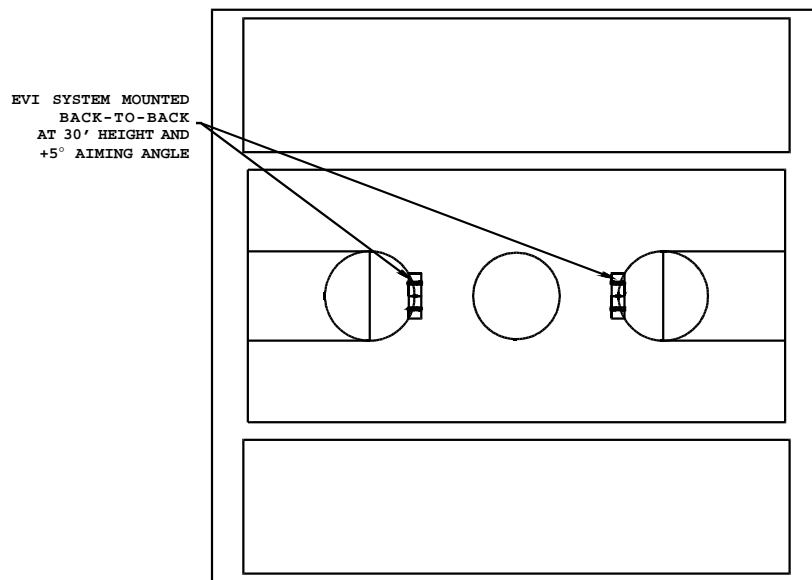
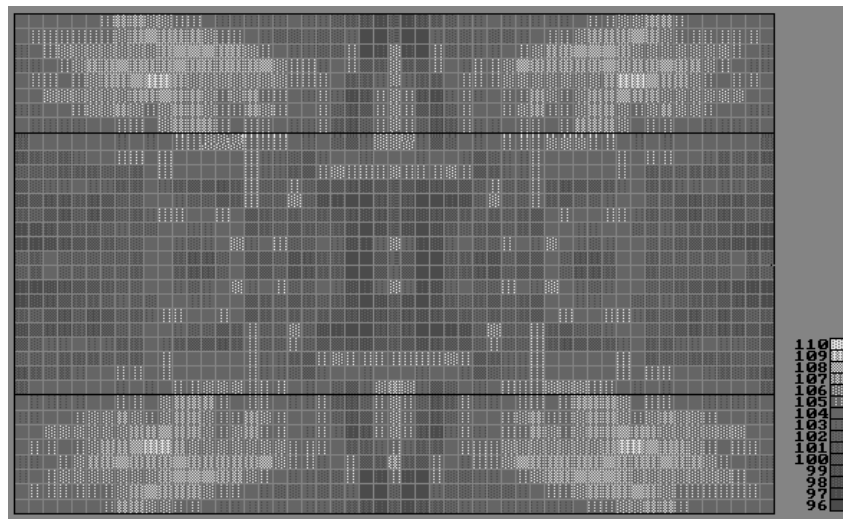

Figure 8



Direct Field SPL



C50

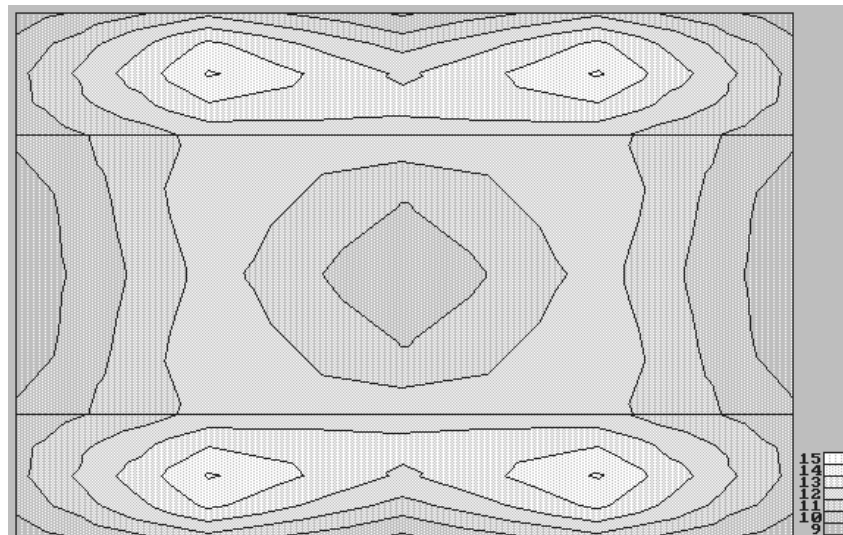
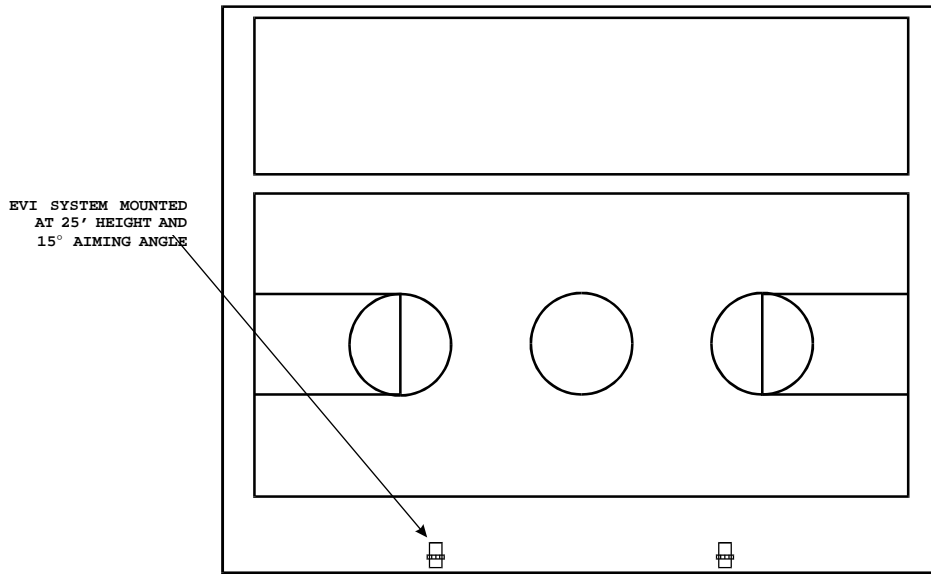
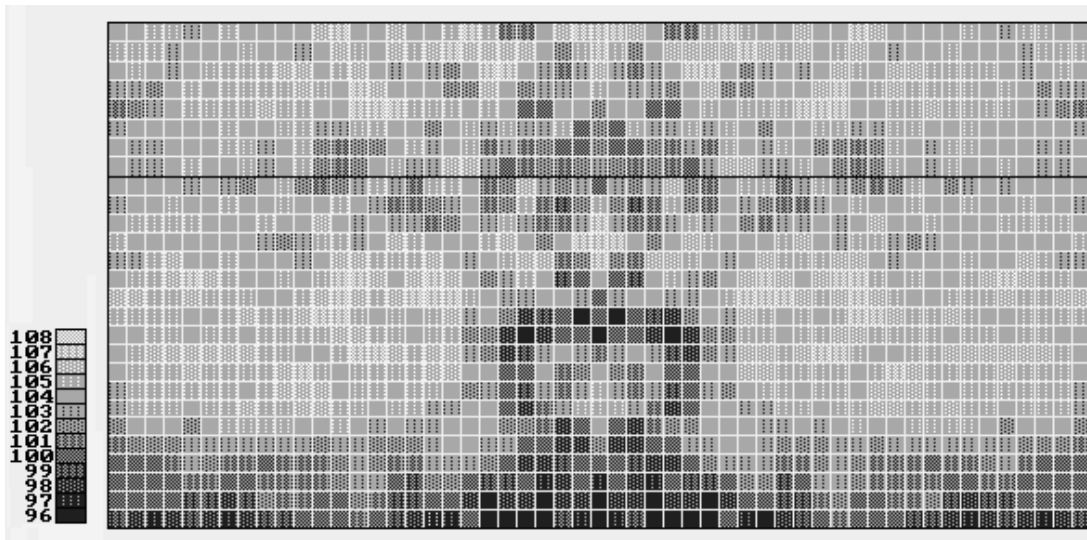

Figure 9



Direct Field SPL



C50

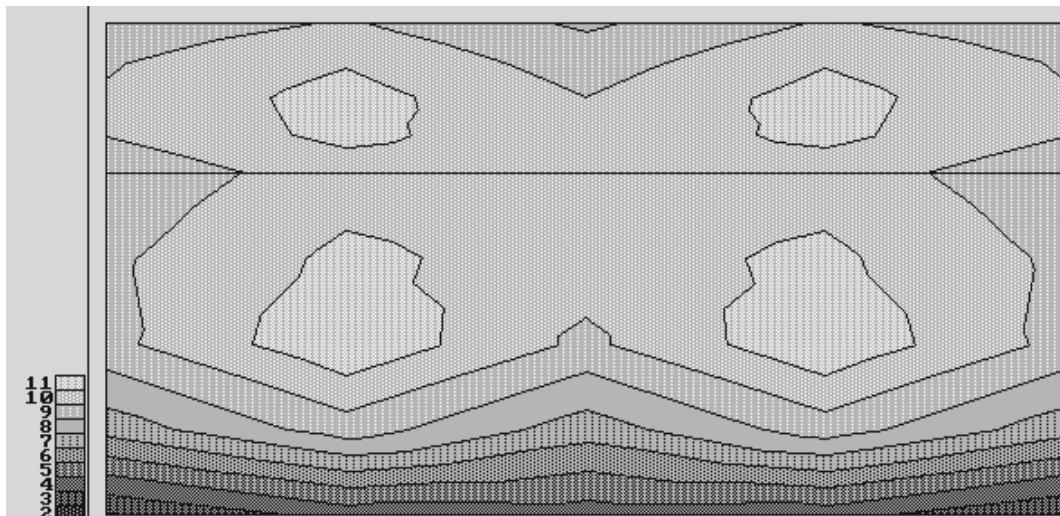
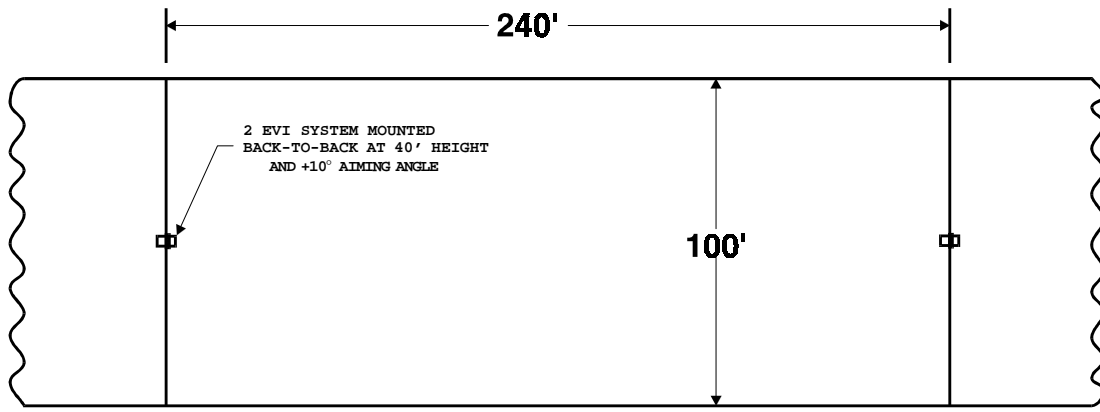
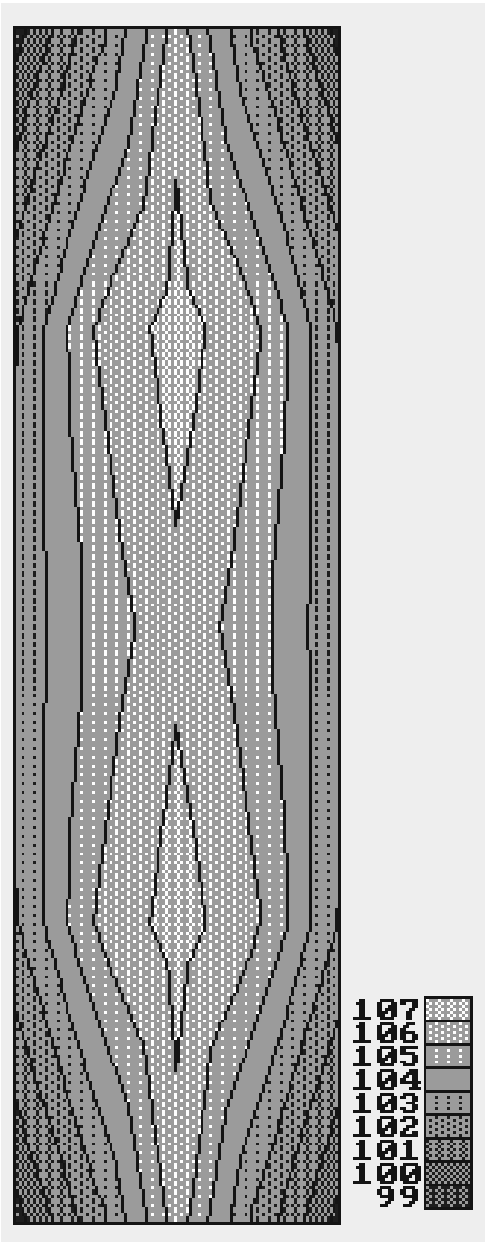

Figure 10



Direct Field SPL



C50

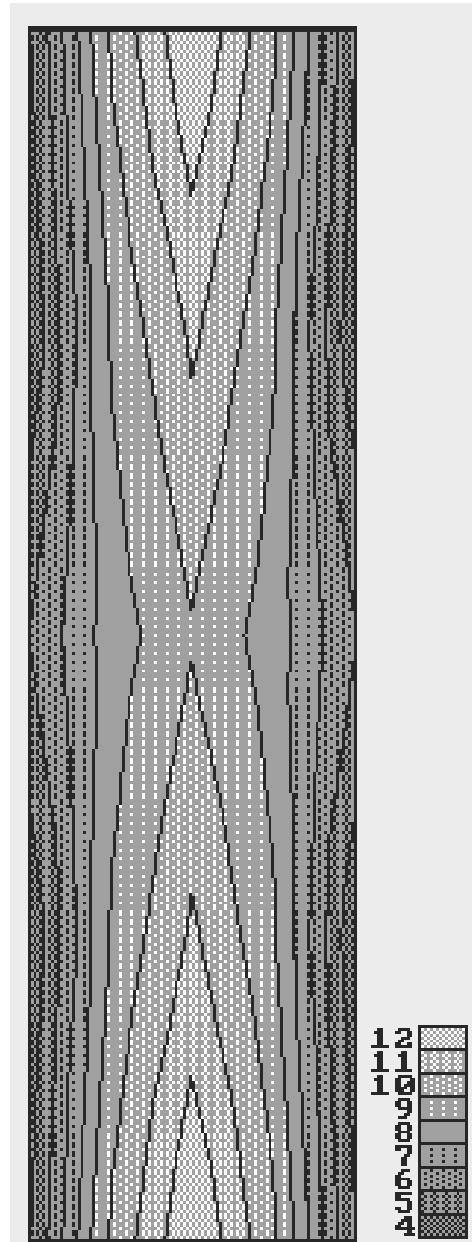

Figure 11

IN A TYPICAL UNDER-BALCONY APPLICATION, THE EVI-28 IS MOUNTED WITH THE TOP SURFACE PARALLEL TO THE FLOOR FOR A 65 FOOT THROW WITH RESTRICTED SPL INTO THE REAR WALKWAY.

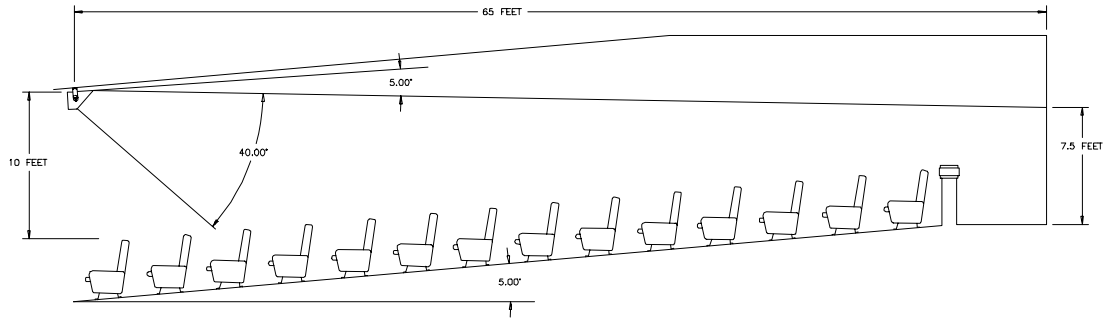

Figure 12

IN A TYPICAL SMALL-ROOM APPLICATION, THE EVI-28 IS MOUNTED SO THE 5-DEGREE DOWN ANGLE POINTS TOWARD THE FAR WALL AT A LITTLE ABOVE STANDING OR SEATED HEAD HEIGHT FOR A 30 FOOT THROW FROM A 9 FOOT CEILING. THE SPL DROPS OFF QUICKLY PAST THE NEARFIELD ANGLE.

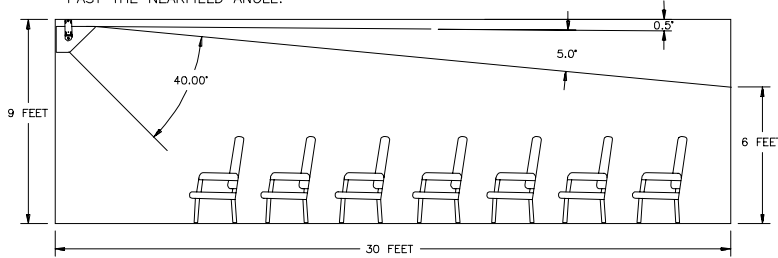

Figure 13

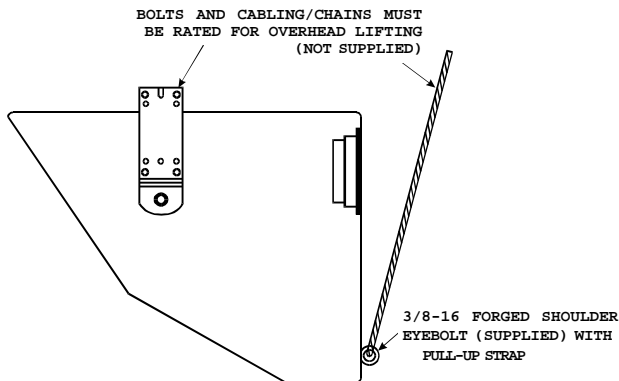

Figure 14

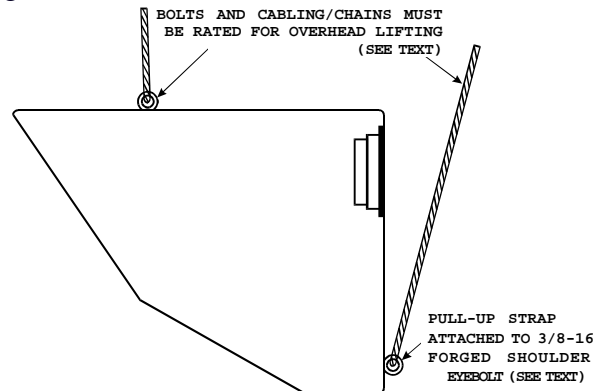
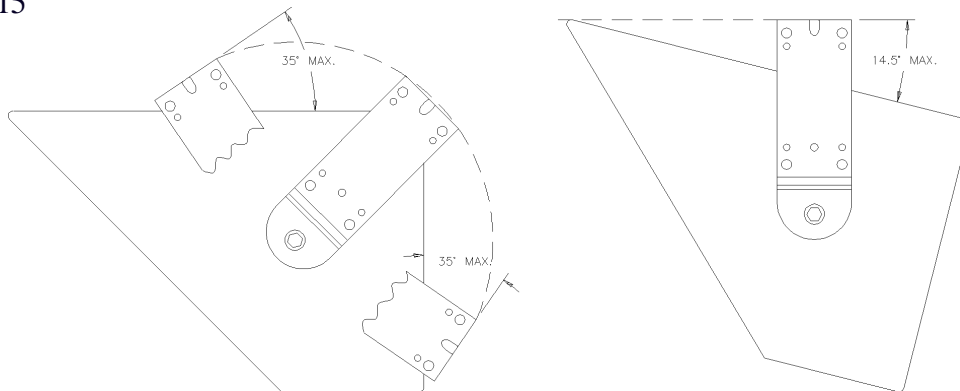

Figure 15



Electro-Voice®

600 Cecil Street, Buchanan, MI 49107

800/234-6831, 616/695-6831, 616/695-1304 Fax

©Telex Communications, Inc. 1998 • Litho in U.S.A.

Part Number 534762—9822

Free Manuals Download Website

<http://myh66.com>

<http://usermanuals.us>

<http://www.somanuals.com>

<http://www.4manuals.cc>

<http://www.manual-lib.com>

<http://www.404manual.com>

<http://www.luxmanual.com>

<http://aubethermostatmanual.com>

Golf course search by state

<http://golfingnear.com>

Email search by domain

<http://emailbydomain.com>

Auto manuals search

<http://auto.somanuals.com>

TV manuals search

<http://tv.somanuals.com>