



**LBI-38389B**

## ***Mobile Communications***

---

**TMX<sup>TM</sup> — 8825 (25W)**

**TMX<sup>TM</sup> — 8810 (10 W)**

---

# **Installation Manual**

## TABLE OF CONTENTS

	<u>Page</u>
INTRODUCTION . . . . .	3
UNPACKING AND CHECKING EQUIPMENT . . . . .	3
STANDARD EQUIPMENT . . . . .	3
OPTIONS . . . . .	3
PLANNING THE INSTALLATION . . . . .	6
EQUIPMENT REQUIRED . . . . .	6
INSTALLATION IN VEHICLES POWERED BY LIQUEFIED (LP) GAS . . . . .	7
RUNNING CABLES . . . . .	8
POWER AND IGNITION CABLES . . . . .	8
INSTALLING THE RADIO . . . . .	11
MICROPHONE CONNECTIONS . . . . .	12
MICROPHONE BRACKET . . . . .	12
ANTENNA . . . . .	13
OPTIONAL ACCESSORIES . . . . .	15
AC POWER SUPPLY (12 VOLTS AT 13 AMPS) . . . . .	15
DESK MICROPHONE OPTION MC1M (MC03) (19B851086P10) . . . . .	15
OPTION CABLE OPTION CC3N (CC08) (19C85158P3) . . . . .	16
UNIVERSAL TONE CABLE OPTION CC3P (CC09) (19C851585P5) . . . . .	17
EXTERNAL SPEAKER OPTION LS1E (LS01) (19C850550) . . . . .	17
EXTERNAL ALARM (HORN) RELAY OPTION SU1C (SU01) (19A705499P1) . . . . .	18
EXTERNAL ALARM ON/OFF SWITCH OPTION SU1F (SU02) (19C851585P7) . . . . .	19
INTERCONNECTION DIAGRAM . . . . .	21
OPTION INTERCONNECTION DIAGRAM . . . . .	22

This manual is published by **Ericsson GE Mobile Communications Inc.**, without any warranty. Improvements and changes to this manual necessitated by typographical errors, inaccuracies of current information, or improvements to programs and/or equipment, may be made by **Ericsson GE Mobile Communications Inc.**, at any time and without notice. Such changes will be incorporated into new editions of this manual. No part of this manual may be reproduced or transmitted in any form or by any means, electronic or mechanical, including photocopying and recording, for any purpose, without the express written permission of **Ericsson GE Mobile Communications Inc.**

Copyright© October 1989, General Electric Company

# INTRODUCTION

This manual contains installation instructions for the TMX-8825 and TMX-8810 Mobile Radios and associated accessories. Included are mounting instructions, for connecting the ignition cable assemblies and suggested cable routings. Interconnection and wiring diagrams are contained in the back of this manual.

## UNPACKING AND CHECKING EQUIPMENT

Carefully unpack the Two-Way Radio. It is recommended that you identify the items ordered and check them off in the box below before discarding the packing material. If any damage has occurred to the equipment during shipment, file a claim with the carrier immediately.

## STANDARD EQUIPMENT

Two-Way Radio  
Microphone 19B801398P4  
Microphone Hanger 19B801398P5  
Battery Power Cable 19B801358P2  
Mounting Hardware Kit 19A138051G11

## OPTIONS

Option PD1A (PD01) - Noise Suppression Kit 19A148539G1

Option PS1C (PS03) - AC Power Supply 121 Volt, 60 Hz, 13  
Amp 19A704647P2

Option PS1D (PS04) - AC Power Supply 121/242 Volt, 50/60 Hz,  
13Amp 19A704647P3

Option MC1M (MC05) - Desk Microphone 19B851086P10

Option CC3N (CC08) - Option Cable 19C851585P3

Option CC3P (CC09) - Universal Tone Cable (requires Option  
CC08) 19C851585P5

Option CC3R (CC10) - Power Cable (20 foot) 19B801358P4

- Option LS1E (LS01) - External Speaker (Dash Mount)  
19C850550G6  
(requires Option CC08)
- Option SU1C (SU01) - External Alarm (Horn) Relay 19A705499P1  
(requires Option CC08) and SU02)
- Option SU1F (SU02) - External Alarm ON/OFF Switch  
19C851585P7  
(requires Option SU01)
- Option MAIL (MA03) - Desk Radio Mounting Wedge 19C851685G2

**NOTE**

The original option numbers for the TMX-8825 and TMX-8810 options have been replaced with new option numbers. both the old and new option numbers are shown for clarity. The new option number is shown first, and the old option number is shown in parentheses. For example:

External Speaker Option LS1E (LS01)--where Option LS1E is the new option number, and (LS01) is the old option number.

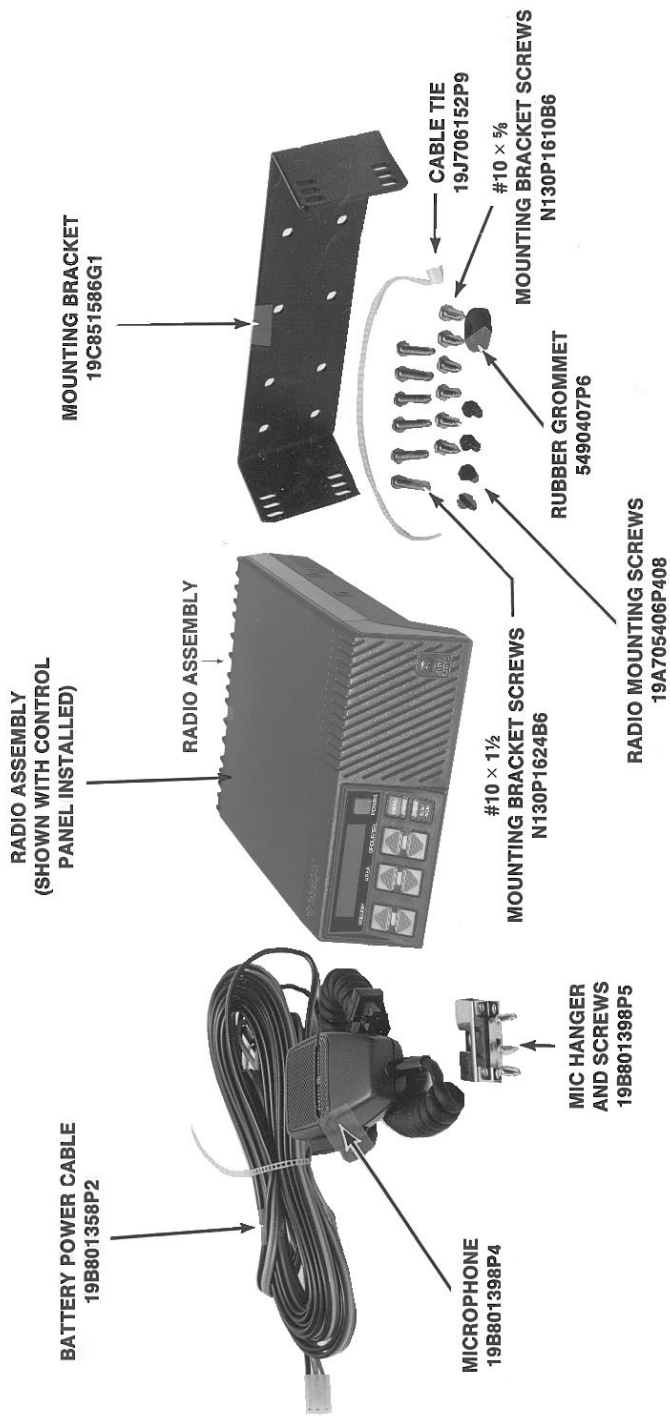

Figure 1 - Radio Components and Mounting Hardware

## WARNING

Interference with Vehicular Electronics - Electronic fuel injection systems, electronic anti-skid braking systems, electronic cruise control systems, etc., are typical of the types of electronic devices which may be prone to malfunction due to the lack of protection from radio frequency energy present when transmitting. If the vehicle contains such equipment, consult the dealer for the make of the vehicle and enlist his aid in determining if such electronic circuits will perform normally when the radio is transmitting.

The accompanying illustrations should help you in your installation.

## PLANNING THE INSTALLATION

Before starting, plan your installation carefully so that it will be:

- Safe for the operator and passengers in the vehicle.
- Safe to operate within easy reach of controls and microphone.
- Protected from damage from water.
- Easy for the serviceman to service.
- Oriented to minimize reflections in LCD display.
- Neat
- Out of the way of auto mechanics.

## EQUIPMENT REQUIRED

The equipment required for installing the radio is:

- Electric Drill
- No. 31 (1/8-inch) drill for No. 8 screws
- No. 27 (9/64-inch) drill for No. 10 screws
- Phillips screwdriver
- Crimp tool for terminals and antenna connector.
- No. 20 TORX<sup>®</sup> driver or 1/4-inch HEX driver for mounting radio
- 5/8-inch punch or hole saw for rubber grommet

It is suggested that you take advantage of the experience of one of the many authorized General Electric Service Stations located throughout the United States by having them install the equipment.

TORX<sup>®</sup> Trademark of CAMCAR Division, TEXTRON, Inc.

### CAUTION

Be careful to avoid damaging some vital part (fuel tank, transmission housing, etc.) of the vehicle when drilling mounting holes. Always check to see how far the mounting screws will extend below the mounting surface before installing.

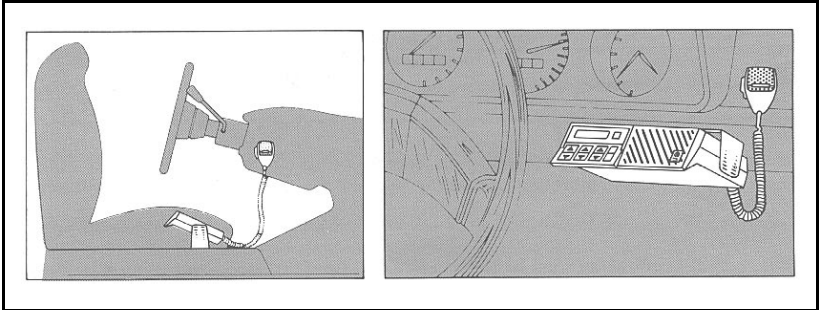

Figure 2 - Typical Hump or Dash Mount

## INSTALLATION IN VEHICLES POWERED BY LIQUEFIED (LP) GAS

### WARNING

Radio installations in vehicles powered by liquefied petroleum gas must conform to the following requirements.

Radio installations in vehicles powered by liquefied petroleum gas with the LP-gas container in the trunk or other sealed-off space within the interior of the vehicle must conform to the National Fire Protection Association Standard NFPA 58 which requires that:

- Space containing radio equipment shall be isolated by a seal from the space containing the LP-gas container and its fitting.
- Outside filling connections shall be used for the LP-gas container.
- The LP-gas container space shall be vented to the outside of the vehicle.

## **RUNNING CABLES**

To assure feasibility of the cable routing you plan to use, it is suggested that you run the cables before mounting the equipment. Be sure to leave some slack in the cables going to the equipment so that the equipment may be pulled out for servicing with the power applied and antenna attached.

Try to route the cables away from locations where they will be exposed to heat (exhaust pipes, mufflers, tailpipes, etc.), battery acids, sharp edges or mechanical damage, or where they will be a nuisance to automobile mechanics, the driver or passengers. Keep wiring away from electronic computer modules, other electronic modules and ignition circuits to help prevent interference to these components and radio equipment.

In addition, try to utilize existing holes in the firewall and trunkwall and the channels above and beneath the doors. You may also use the channel through door and window columns, where they are convenient for running cables, unless you plan to install rigid or flexible conduit in which to run the cables.

## **POWER AND IGNITION CABLES**

The Power Cable consists of a red lead, an orange lead, a black lead, a 3 pin systems plug, and a set of fuses and fuse holders to be installed (See Figure 3).

To install the Power Cable, start with the plug end of the cable at the location of the radio and run the three leads to the firewall, drill a 5/8 inch hole and insert a rubber grommet (customer supplied).

To install the fuses: 1) Cut off 12 to 18 inches from the red and orange wires; 2) Strip back the insulation approximately 3/8 of an inch on each end of the wires; 3) Insert the stripped end of each wire into the small opening at the end of each fuse holder section and crimp the wire to the fuse holder section; and 4) Place the fuse into the large section of the fuse holder and snap the large end of the fuse holder to the small end of the fuse holder.

Connect the orange fused lead to the positive (+) battery terminal, and the black to the negative (-) battery terminal. Always locate the fuse as close to the battery as possible.

Connect the red lead to the ignition "on" sense point (preferably an "Accessory" point on the fuse panel that is switched on when the ignition switch is in the accessory position and in the "run" position). Locate the fuse as close as possible to the accessory point.



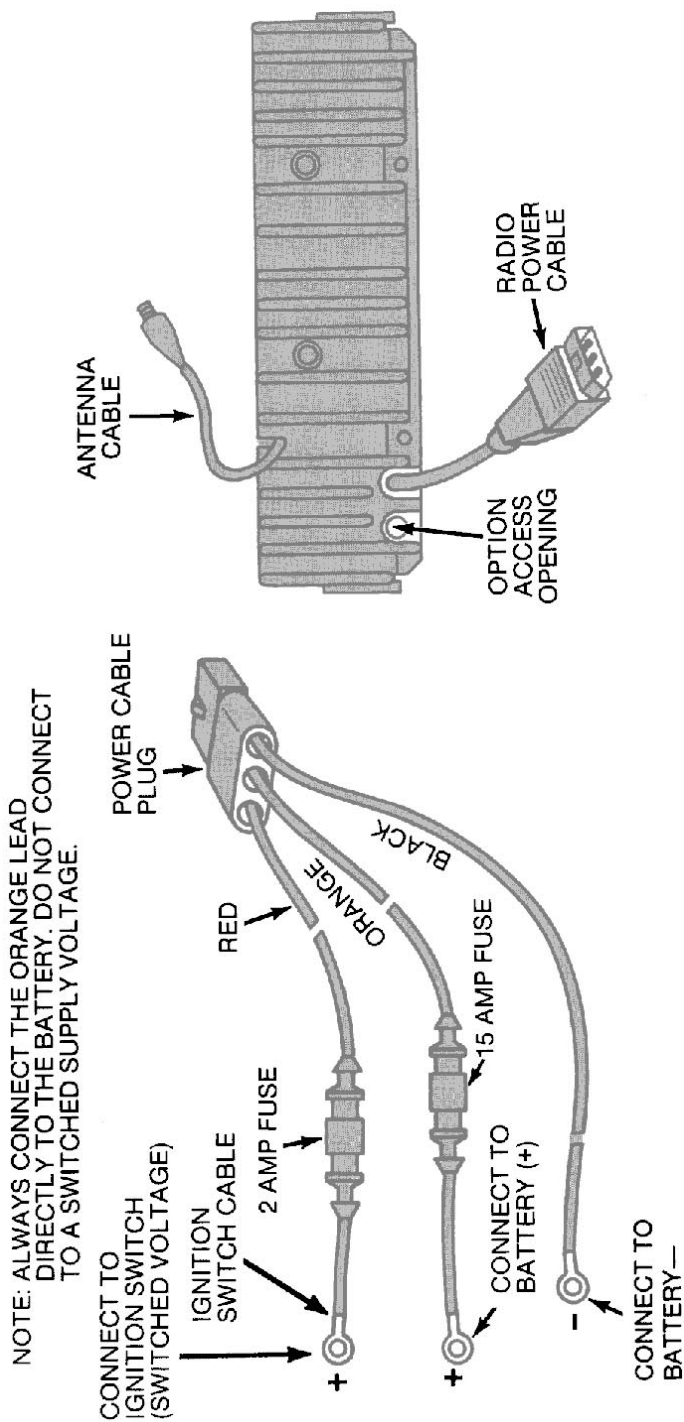

Figure 3 - Power Cable

### NOTE

With some accessory points, the voltage only drops when the ignition switch is in the START position. A connection point should be used where the voltage is completely off when the ignition switch is in the START position.

### CAUTION

Certain problems may be encountered when accessory equipment is connected to the ignition or accessory lines of the vehicle, where these lines may have large filter capacitors or a leakage path present.

If the radio does not turn off within a reasonable amount of time after the ignition is turned off, first try a different accessory or ignition sense pick up point in the vehicle. Many vehicles have more than one circuit that is switched by the ignition switch, and one may be available that does not have large filter capacitors or a leakage path present.

If a different pickup point cannot be found, then add a 470-ohm 1-watt resistor from the ignition sense pickup point to ground. This will discharge the capacitor(s) or reduce the leakage voltage to a low value. Current drain through this resistor will be minimal (less than 0.03A) when the ignition is switched on.

Coil up the surplus cables and secure them out of the way with the retaining strap provided. Be sure to leave some slack in the cables going to the radio so that it may be pulled out for servicing with power applied.

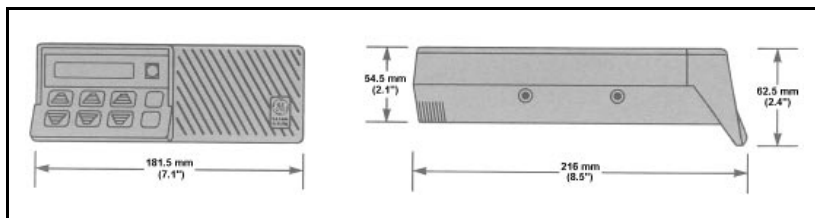

Figure 4 - Mounting Dimensions

## INSTALLING THE RADIO

Mount the radio so that the controls are within reach of the operator. Use the mounting bracket as a template to locate the holes, and mount the radio as shown in Figure 5. Be sure to leave enough room at the rear of the radio for cable connections.

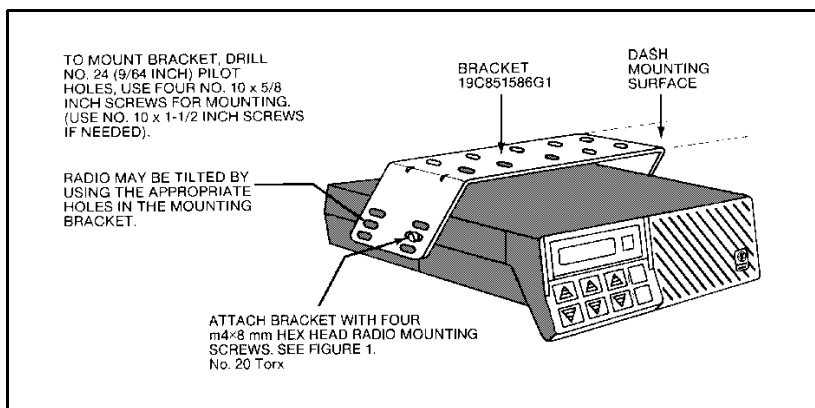

Figure 5 - Installing Mounting Bracket

# MICROPHONE CONNECTIONS

Normally, the microphone is shipped connected to the microphone jack on the bottom of the radio. A cable clamp is used for strain relief and is attached to the bottom of the radio using a M4-0.7x8 Hex Head screw.

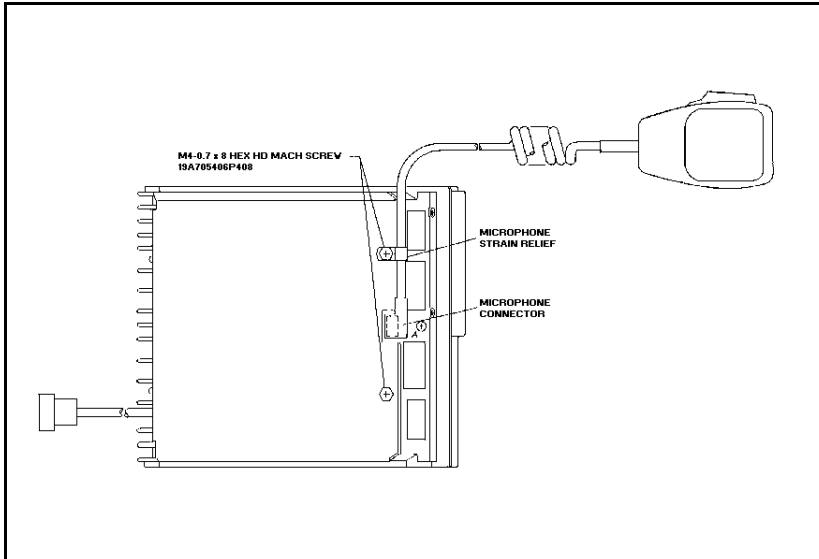

Figure 6 - Microphone Connection and Strain Relief

## MICROPHONE BRACKET

Mount the magnetic microphone bracket where it will be within easy reach of the operator, but will not interfere with safe operation of the vehicle. Refer to Figure 7 for bracket dimensions. The microphone must be placed in the hanger so that the cord end of the mike housing is over the magnet assembly. To mount the bracket, drill three No. 32 (1/8-inch) pilot holes, and use the No. 8 x 5/8 screws supplied with the bracket.

### NOTE

The magnetic hookswitch must be used with Channel Guard applications.

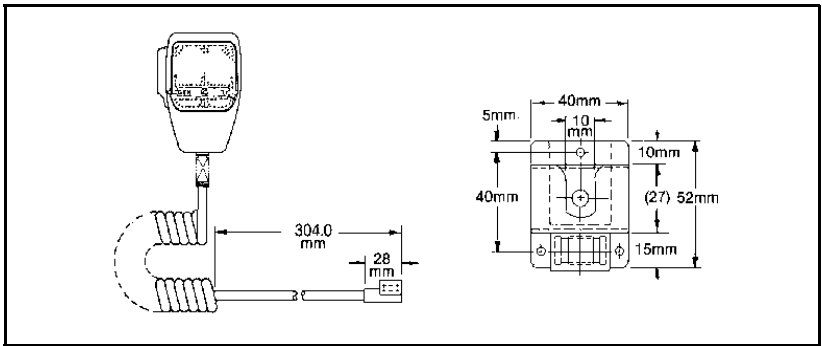

Figure 7 - Microphone Bracket Mounting

## ANTENNA

Installation instructions for the antenna are packaged with the antenna. The antenna must be installed in accordance with good engineering practices for optimum results.

A permanent mount type of antenna should be located in the center of the roof or rear deck. Glass mounted antennas should be kept as high as possible in the center of the rear window. Some states have laws restricting vision obstructing items from the window. Be familiar with local laws before installing glass mount antennas.

Try to route the cable away from locations where it will be exposed to heat, sharp edges or mechanical damage, and where it will be out of the way of the driver, passengers, or vehicle mechanics. Wherever possible, existing holes in the trunk wall, and the channels above or beneath doors and window columns should be utilized.

Avoid routing the antenna cable near any electronic modules or along side any vehicle wiring.

Connect the antenna cable to the TNC connector on the radio.

### CAUTION

In station applications, the radio may not operate properly with the antenna mounted near the radio. Always mount the antenna at least 5 feet from the radio.

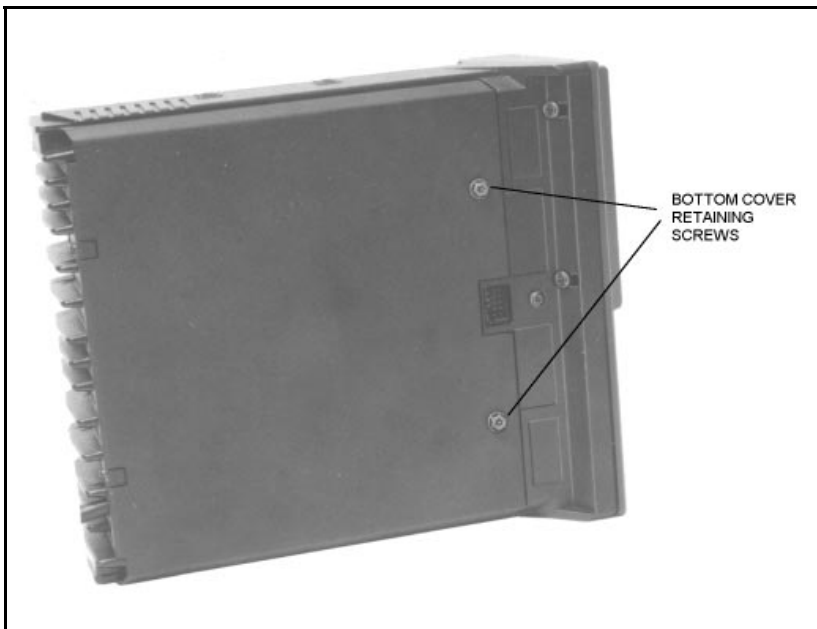

Figure 8 - Bottom View

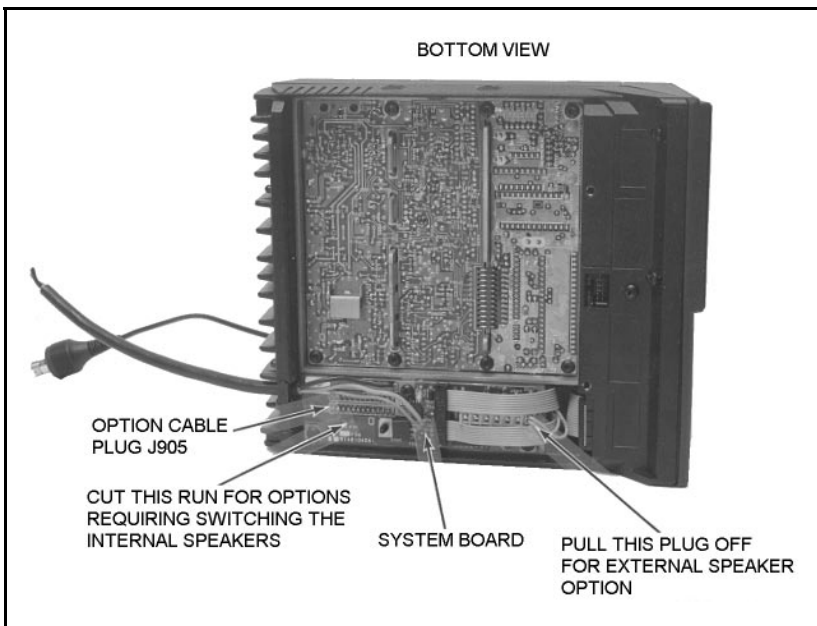

Figure 9 - Bottom View (Cover Removed)

## OPTIONAL ACCESSORIES

### AC POWER SUPPLY (12 VOLTS AT 13 AMPS)

**OPTION PS1C (PS01) (19A704647P2) 121 Volts, 60 Hz**

**OPTION PS1D (PS02) (19A704647P3) 121/242 Volts,50/60 Hz**

1. An empty connector housing and terminals are provided with the power supply. Crimp three terminals on the end of the 9 foot power cable provided with the radio. An optional 20 foot cable is available.
2. Insert the orange and red leads into pins 3, 6, or 9 of the connector housing. Insert the black lead into pins 1, 4, or 7. Figure 10 provides an illustration of the empty connector housing which plugs into J1 of the power supply.

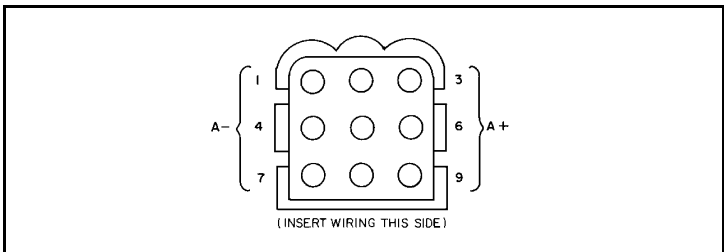

Figure 10 - Rear View of Empty Connector Housing

### DESK MICROPHONE OPTION MC1M (MC03) (19B851086P10)

1. The desk microphone plugs into the microphone jack on the bottom of the radio. Remove the standard microphone and reuse the same cable clamp for strain relief.
2. If needed, adjust the microphone gain depending on the normal talking distance from the microphone. Access the gain control through the small hole on the bottom of the microphone base.
3. The microphone audio is normally switched off when the PTT button is released. If the microphone audio needs to be active at all times, a jumper must be placed across the switch inside the microphone.

# OPTION CABLE OPTION CC3N (CC08) (19C85158P3)

The Option Cable brings all option connections from the System Board through the back of the radio to the outside. This cable is required with all external options. Supplied with the Option Cable is the empty connector housing which plugs into P2 of the Option Cable. Pins supplied on the ends of the wires of each option (Molex #39-00-0060) are inserted into this connector housing. Refer to the Interconnection Diagram in the back of this manual. See Figure 11 for pin locations.

1. Remove the bottom cover of the radio by removing the two bottom cover retaining screws. Refer to Figure 8.
2. Remove the rubber plug from the slotted opening in the rear of the radio adjacent to the power cable.
3. Plug the Option Cable into J905A on the System Board and push the strain relief on the cable into the slotted opening. Refer to Figure 9.
4. Before replacing the bottom cover, check to see if the particular option being added requires unplugging the internal speaker or changing a jumper (Refer to the section describing the option).

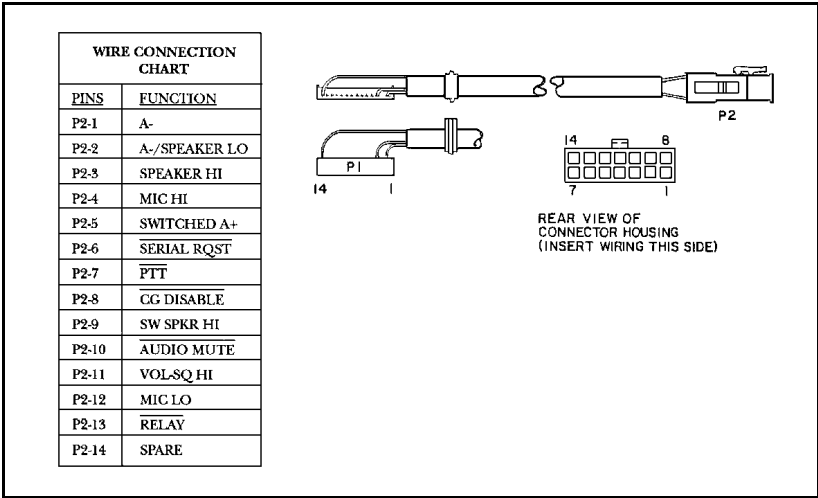

Figure 11 - Option Cable Pin Locations



## UNIVERSAL TONE CABLE OPTION CC3P (CC09) (19C851585P5)

The Universal Tone Cable option requires the use of Option Cable CC3N (CC08). P1 of the Universal Tone Cable plugs into P2 of the Option Cable. The Universal Tone Cable Option provides all option connections on P2 and a 9-pin Winchester connector for connecting to external tone encoders or decoders. See Figure 12.

If the tone decoder requires switching the internal speaker, remove the radio bottom cover and cut the PC run between holes 6 and 7 on the System Board. Refer to Figure 9 for PC run identification.

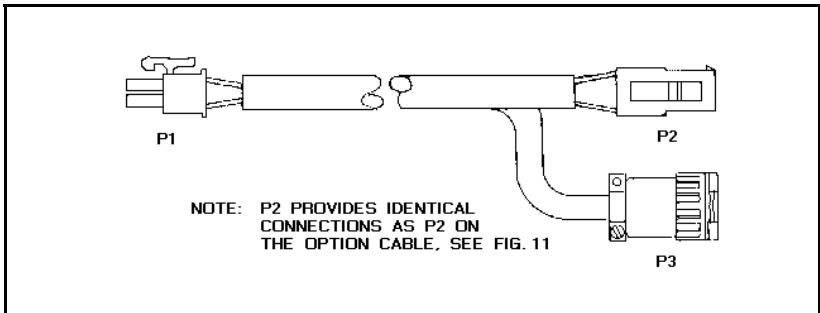

Figure 12 - Tone Cable Pin Location

## EXTERNAL SPEAKER OPTION LS1E (LS01) (19C850550)

1. Mount the External Speaker where the sound will be directed to the operator but not interfere with his vision or provide a hazard to passengers in case of an accident. The speaker may be mounted on the lower edge of the instrument panel, the firewall, or above the windshield in some trucks. Use the mounting bracket as a template for locating the mounting holes, and mount the speaker as shown in Figure 13.
2. Install the Option Cable CC3N (CC08) if not already present.
3. Before replacing the bottom cover of the radio, unplug the internal speaker from A5 J904 on the System Board. Refer to Figure 9.
4. Pins are supplied on the ends of the speaker leads. Push these pins into pins 2 and 9 of the connector housing supplied with the Option Cable. Refer to Figure 11.

5. Plug the connector into P2 of the Option Cable.

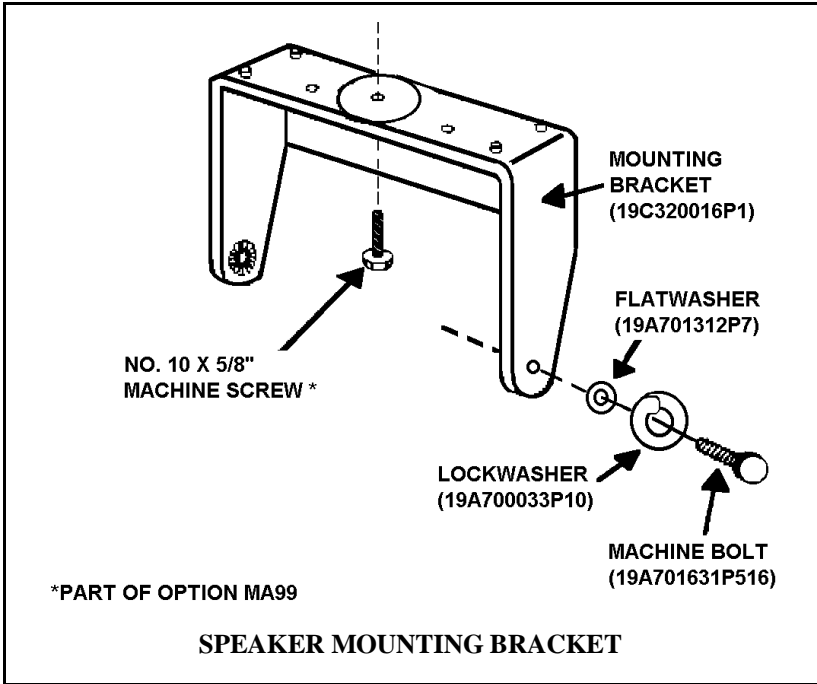

Figure 13 - Mounting the Speaker

## **EXTERNAL ALARM (HORN) RELAY OPTION SU1C (SUO1) (19A705499P1)**

The Alarm Relay Option requires the the use of Option Cable CC3N (CC08). External Alarm ON/OFF Switch Option SU1F (SU02) is required to allow the horn relay to be disabled when desired. The Option consists of the following items:

- (1) Relay (19A149299P1)
- (1) Fuse holder
- (1) Fuse, 1 amp, 250 volt
- 4 feet red wire, AWG #18 with Ring Tongue Terminal for 3/8 stud
- 6 feet black wire, AWG #18 with Molex #39-00-0060 terminal
- (5) Insulated 1/4 inch spade tab receptacles
- (1) Ring Tongue Terminal for 3/8 inch stud
- (1) #8 x 3/4 long Type A sheet metal screw
- (1) Nut Plate for #8 screw

1. Install the Option Cable CC3N (CC08) in the radio.
2. Fasten the relay in the desired location, close to the voltage source, using one #8 x 3/4 inch self-tapping screw.
3. Crimp an insulated 1/4 inch spade tab receptacle to one end of the #18 red wire. Connect the receptacle to relay lug #86. Cut the red lead so the fuse assembly is close to the voltage source. Install the fuse holder. Attach the other end of the fuse lead to the voltage source with appropriate hardware. See Figure 14.
4. Insert the black wire with the Molex terminal into pin 13 of the option connector housing supplied with the option cable. Plug the connector into the option cable.

**NOTE**

If External Alarm ON/OFF Switch Option SU1F (SU02) is used in conjunction with this option, refer to External Alarm ON/OFF Switch Option SU1F (SU02).

5. Crimp insulated 1/4 inch spade tab receptacle to the other end of the black wire. Connect the receptacle to relay lug #85.
6. Connect the horn or light circuit to lugs # 30 and #87 (not 87a) using the insulated 1/4 inch spade tab receptacles.

**NOTE**

The relay contact make/break current and voltage rating is 30 amps at 16 volts.

## **EXTERNAL ALARM ON/OFF SWITCH OPTION SU1F (SU02) (19C851585P7)**

The External Alarm Switch, when used with External Alarm Relay Option SU01, allows the alarm relay to be disabled. Connect the switch in series with the black wire from the relay. Insert the wire with the Molex terminal into pin 13 of the option cable connector housing. Splice the other switch lead to the black wire from the relay. See Figure 14.

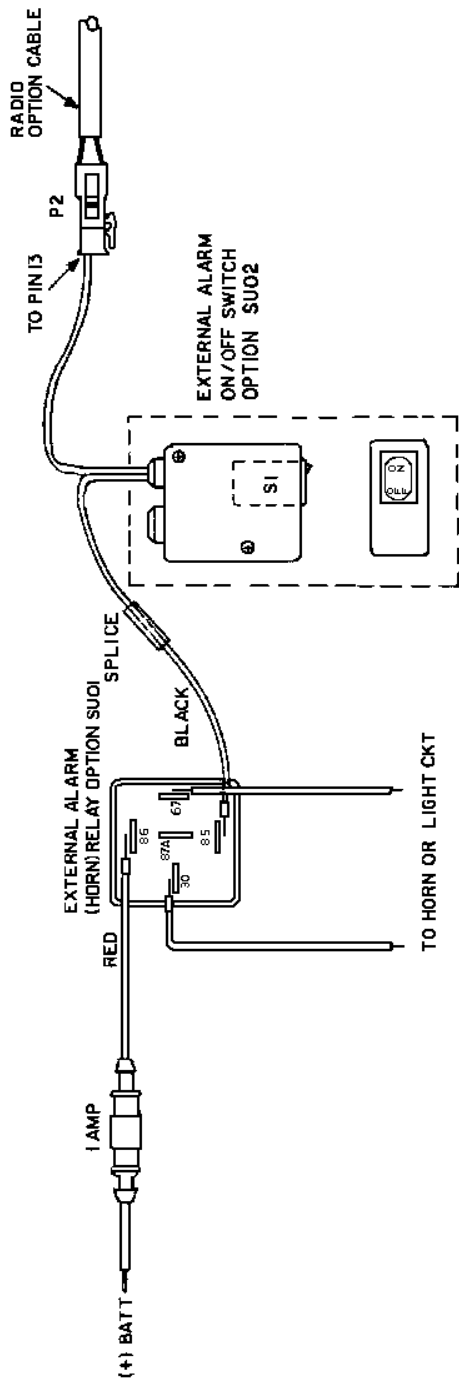
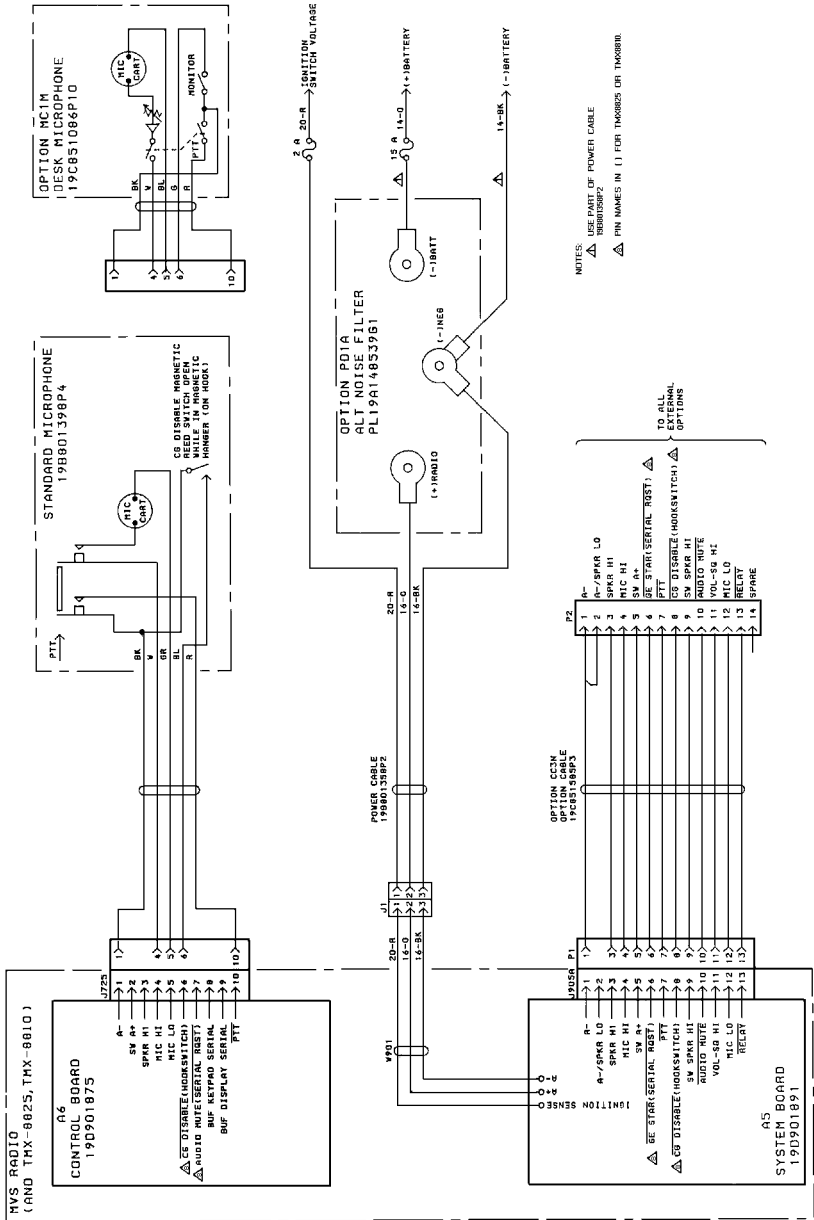

Figure 14 - External Alarm Relay and ON/OFF Switch

# INTERCONNECTION DIAGRAM



(19D901983 Sh 2 Rev.4)

# OPTION INTERCONNECTION DIAGRAM

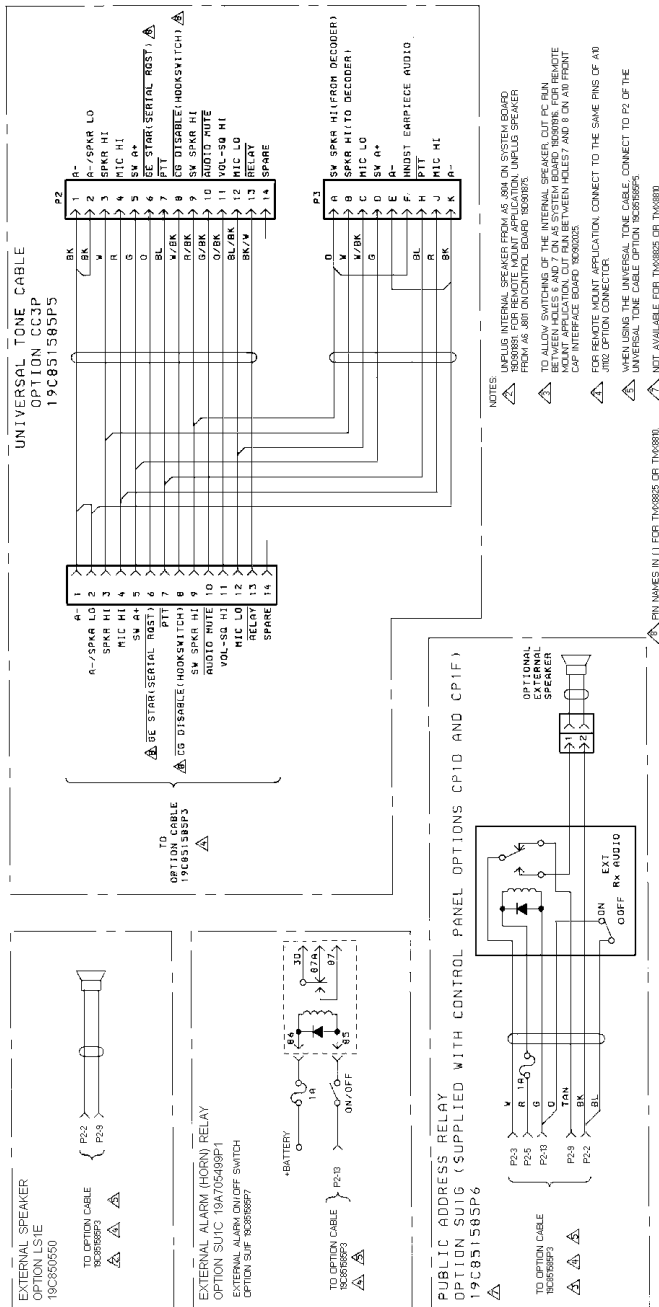

(19D901983 Sh 3 Rev.3)

# NOTES



**Ericsson GE Mobile Communications Inc.**  
Mountain View Road • Lynchburg, Virginia 24502

Printed in U.S.A.



## Free Manuals Download Website

<http://myh66.com>

<http://usermanuals.us>

<http://www.somanuals.com>

<http://www.4manuals.cc>

<http://www.manual-lib.com>

<http://www.404manual.com>

<http://www.luxmanual.com>

<http://aubethermostatmanual.com>

Golf course search by state

<http://golfingnear.com>

Email search by domain

<http://emailbydomain.com>

Auto manuals search

<http://auto.somanuals.com>

TV manuals search

<http://tv.somanuals.com>