

Operation Instruction



1/3" CCD Outdoor Day/Night Vandal-Resistant Dome Camera ED560

Operation Instruction

© 2008 EverFocus Electronics Corp

Please read this manual first for correct installation and operation. This manual should be retained for future reference. The information in this manual was current when published. The manufacturer reserves the right to revise and improve its products. All specifications are therefore subject to change without notice.

All rights reserved. No part of the contents of this manual may be reproduced or transmitted in any form or by any means without written permission of the EverFocus Electronics Corporation.

Precautions

1. Do not place any object on top of the cover.
2. Be careful when handling the camera, do not drop it or subject it to strong shock or vibration to prevent any damages to it. Do not disassemble it or place it on an unstable base.
3. Install the camera away from TV, radio transmitter, magnet, electric motor, transformer, audio speakers because the magnetic fields generate from above devices will distort the video image.
4. Install the camera away from stoves, or other heat generating devices as the high temperature could cause deformation, discoloration or other damages of the camera. Install the camera at where the temperature range will stay between -10°C to 50°C (14°F to 122°F).
5. Never aim the camera at the sun or other extremely bright objects whether it is in use or not.
6. Do not touch the surface of CCD sensor by hand directly. Use a soft cloth to remove the dirt from the camera body. Use lens tissue or a cotton tipped applicator and ethanol to clean the CCD sensor and the camera lens. When the camera is not in use, put the cover cap on the lens mount.
7. All warnings on the products and in the operating instructions should be adhered to.
8. Do not use attachments not recommended by the appliance manufacturer as they may cause hazards.
9. Do not allow anything to rest on the power cord. Do not locate this appliance where the cord will be abused by persons walking on it.
10. Do not overload wall outlets and extension cords as this can result in fire or electric shock.

11. Never push objects of any kind into his appliance through cabinet slots as they may touch dangerous voltage points or short out parts that could result in fire or electric shock.
12. Refer all work related to the installation of this product to qualified service personnel or system installers.

Federal Communication Commission Interference Statement

This equipment has been tested and found to comply with the limits for a Class A digital device, pursuant to Part 15 of the FCC Rules. These limits are designed to provide reasonable protection against harmful interference in a residential installation. This equipment generates, uses and can radiate radio frequency energy and, if not installed and used in accordance with the instructions, may cause harmful interference to radio communications. However, there is no guarantee that interference will not occur in a particular installation. If this equipment does cause harmful interference to radio or television reception, which can be determined by turning the equipment off and on, the user is encouraged to try to correct the interference by one of the following measures:

- Reorient or relocate the receiving antenna.
- Increase the separation between the equipment and receiver.
- Connect the equipment into an outlet on a circuit different from that to which the receiver is connected.
- Consult the dealer or an experienced radio/TV technician for help.

FCC Caution: Any changes or modifications not expressly approved by the party responsible for compliance could void the user's authority to operate this equipment.

This device complies with Part 15 of the FCC Rules. Operation is subject to the following two conditions: (1) This device may not cause harmful interference, and (2) this device must accept any interference received, including interference that may cause undesired operation.

Table of Contents

1. Product Overview.....	6
1.1 Features	7
1.2 Accessory Parts List	8
1.3 Specifications	10
1.4 Dimensions.....	11
1.5 Camera Component Description	12
1.6 Front and Back Panel Layout.....	13
1.7 Related Products	15
2. INSTALLATION.....	16
2.1 Mounting Camera.....	17
2.1.1 Drill the Holes	17
2.1.2 Mounting	19
2.2 Adjusting Camera	21
2.2.1 Adjusting Camera Position	21
2.2.2 Adjusting Zoom and Focus	22
2.2.3 Camera Setting.....	24
2.2.3.1 OSD User Setup Menu.....	24
2.2.4 Close the Camera Cover	25
3. OSD Menu & Configuration.....	28

3.1 OSD Menu Setup	28
3.1.1 LENS.....	29
3.1.2 Shutter	29
3.1.3 White Balance Control.....	31
3.1.4 BACKLIHGT	32
3.1.5 AGC (Auto Gain Control)	33
3.1.6 DNR (Dynamic Noise Reduction)	34
3.1.7 SENS-UP.....	35
3.1.8 SPECIAL	36
3.1.8.1 CAMERA ID.....	37
3.1.8.2 COLOR ADJ	38
3.1.8.3 SYNC	38
3.1.8.4 MOTION DETECTION.....	39
3.1.8.5 PRIVACY	42
3.1.8.6 MIRROR	44
3.1.8.7 SHARPNESS	45
3.1.8.8 RESET.....	45
3.1.8.9 RETURN.....	46
3.1.9 EXIT.....	46

Product Overview

The new ED560 is designed with the advanced 16-bit Digital Signal Processor (DSP) for powerful processing capability to show 560TVL horizontal resolution. Designed with SENS-UP 128X slow shutter technology, ED560 captures images in almost darkness with super high sensitivity of 0.002lux. With 3-Axis rotation, ED560 offers quick and flexible wall or ceiling installation. In addition, ED560 is weatherproof IP66 rated, vandal resistant to avoid any intentional destruction. ED560 is ideal for 24/7 surveillance in all outdoor application. It is available in model with or without True Day/Night function.

1.1 Features

- 1/3" SONY Super HAD CCD for excellent picture quality
- 560TVL of horizontal resolution with the advanced 16-bit Digital Signal Processor (DSP)
- ED560 captures clear images in almost darkness with 0.002 Lux
- SENS-UP Slow Shutter 128X max.
- True Day/Night function with removable IR cut filter (ED560T)
- Built-in DNR (Dynamic Noise Reduction) for noise reduction and a 70% saving of disk storage
- 3-Axis rotation
- Easy wall or ceiling installation
- OSD setting menu
- Support Motion Detection function
- Support Privacy function
- Vandal resistant
- Weatherproof IP66 rated

1.2 Accessory Parts List



Please be careful when you unpack the box due to the electronics devices inside. Check and make sure that you have all the items listed below inside the original box:

- Camera Unit x 1
- Operation Manual x 1
- Mounting kit includes:
 - Long Screws x 3 (for mounting base)
 - Expanding Screws x 3
 - Washer x 3
- Circle Installation Sticker x 1
- Video Cable x 1



- Extension Power Cable x 1



- Desiccant Pack x 1



- Focus Aiding Lens Cap(for 9~22mm models only) x 1



Please Note: If an item appears to have been damaged in shipment, replace it properly in its carton and notify the shipper. If any items are missing, notify your EverFocus Electronics Corp. Sales Representative or Customer Service. The shipping carton is the safest container in which the unit may be transported. Save it for possible future use.

1.3 Specifications

Items	Parameter
Pickup Device	1/3" SONY Super HAD CCD
Video Format	NTSC or PAL
Scanning System	NTSC:525 TVL, 60 fields/sec PAL:625 TVL, 50 fields/sec
Picture Elements	768 x 494(NTSC); 752 x 582 (PAL)
Horizontal Resolution	560 TVL
Sensitivity	0.002Lux (SENS-UP 128x) ; 0.25Lux/ F=1.2
S/N Ratio	Over 50 dB(AGC off)
Electronic Shutter	1/50(1/60)~1/100,000
Lens Type	Vari-focal lens, Auto Iris f=2.9~10mm/F=1.2 ;f=9~22mm/F=1.6 *Lens models and availability vary in different regions
Back Light Comp.	Off/Low/Middle/High Adjustable
Auto Gain Control	Off/Low/Middle/High Adjustable
Auto White Balance	ATW(2500 °K ~8300 °K)/AWC/Manual
Gamma Correction	0.45
True Day & Night	Yes
Flickerless	Yes
Video Output	2 video outputs BNC 1.0V _{p-p} , 75ohm Additional testing video output 1.0V _{p-p} , 75ohm
Sync. Mode	Line Lock/Internal sync.
H-Mirror	Yes
OSD Menu	Yes
Vandal Resistant	Yes
Power Source	12VDC/24VAC
Power Consumption	24VAC 5VA max 12VDC 3.5W max
Dimensions	123mm(O.D.) x 107.8mm (H) ; 4.8" (O.D.) x 4.2" (H)
Weight	0.74 kg / 1.6 lbs
Operating Temperature	-10°C~50°C ; 14°F~122°F (20%~80% Humidity)
Weatherproof	IP66

1.4 Dimensions

123mm x 107.8mm ; 4.8" x 4.2"

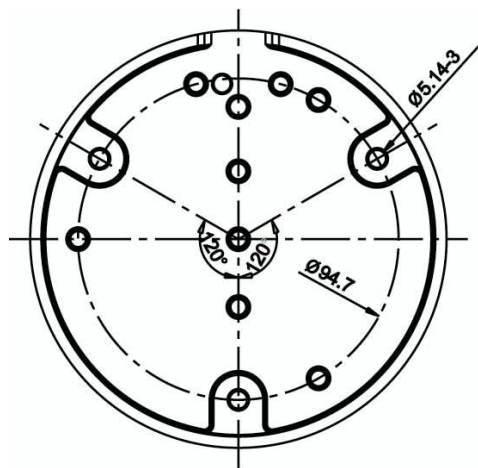
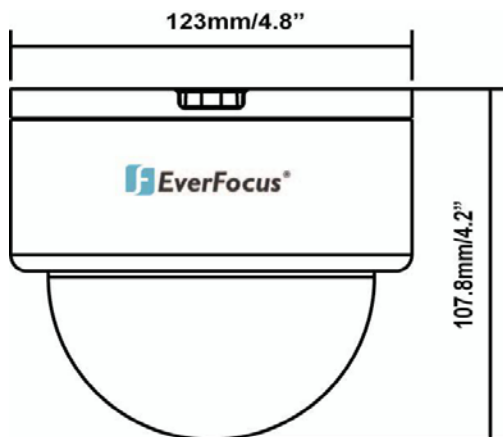

1.5 Camera Component Description



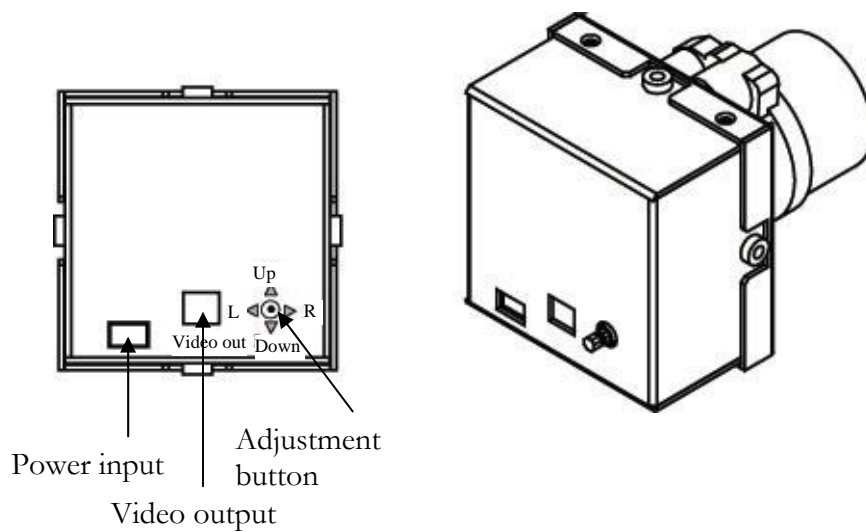

1.6 Front and Back Panel Layout

Front Panel Layout:

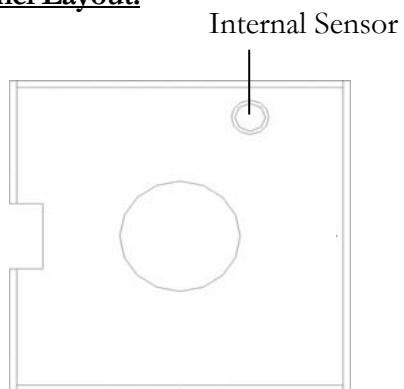

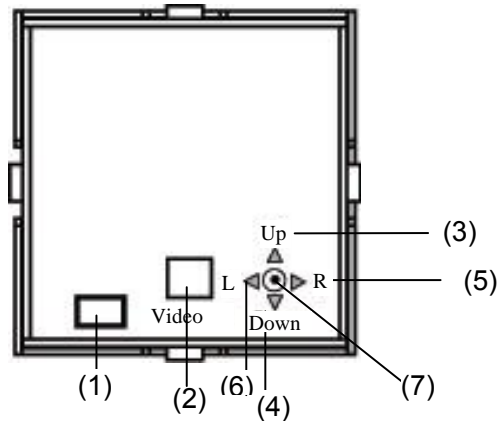
Back Panel Layout:**(1) Power Input Terminal & Video Output Connector**

Connect to the appropriate power to each model. Video Output connector is for connecting the video output of the camera to a color monitor or other video devices through a 75 Ohm type coaxial cable with BNC female connector at backside of the camera.

(2) Second Video Output Connector

When installing the camera, you can use second video connector to connect a portable monitor, this will allow you to easily adjust camera' angle.

(3) Up: Adjust the switch to move the cursor upwards. This is used to select the item need to be set.

(4) Down: Adjust the switch to move the cursor downwards. This is used to select the item need to be set.

(5) Right: Adjust the switch to right direction. This is used to select or adjust the parameters of the selected item.

(6) Left: Adjust the switch to left direction. This is used to select or adjust the parameters of the selected item.

(7) Set button: This button is used to enter setup menu. If the item has its own setting menu (sign ) , press this button again to display the setup menu.

1.7 Related Products

In addition, you may order the following EverFocus products which are recommended for use with the camera to achieve the best performance:

- L Type Bracket



- EN220 5.6 inch LCD Test Monitor



Installation

This chapter will describe, in general terms, how to install the ED560 camera.

STEPS:

2.1. Mounting Camera:

1. Drill the Holes. See 2.1.1
2. Mounting: See 2.1.2

2.2. Adjusting Camera:

1. Adjust the camera position. See 2.2.1
2. Adjusting Zoom and Focus See 2.2.2
3. Camera Setting. See 2.2.3
4. How to close camera cover after installation. See 2.2.4

Warning

- To prevent electrical shock, turn off the electrical power before making electrical connections.
- Do not expose the appliance to water or moisture, nor try to operate it in wet areas.

2.1 Mounting Camera

2.1 .1 Drill the Holes

1. Paste the drilling template on the ceiling or wall
2. Use the tool to drill 4 holes, 3 for screw A, B and C, 1 for power/video cable.

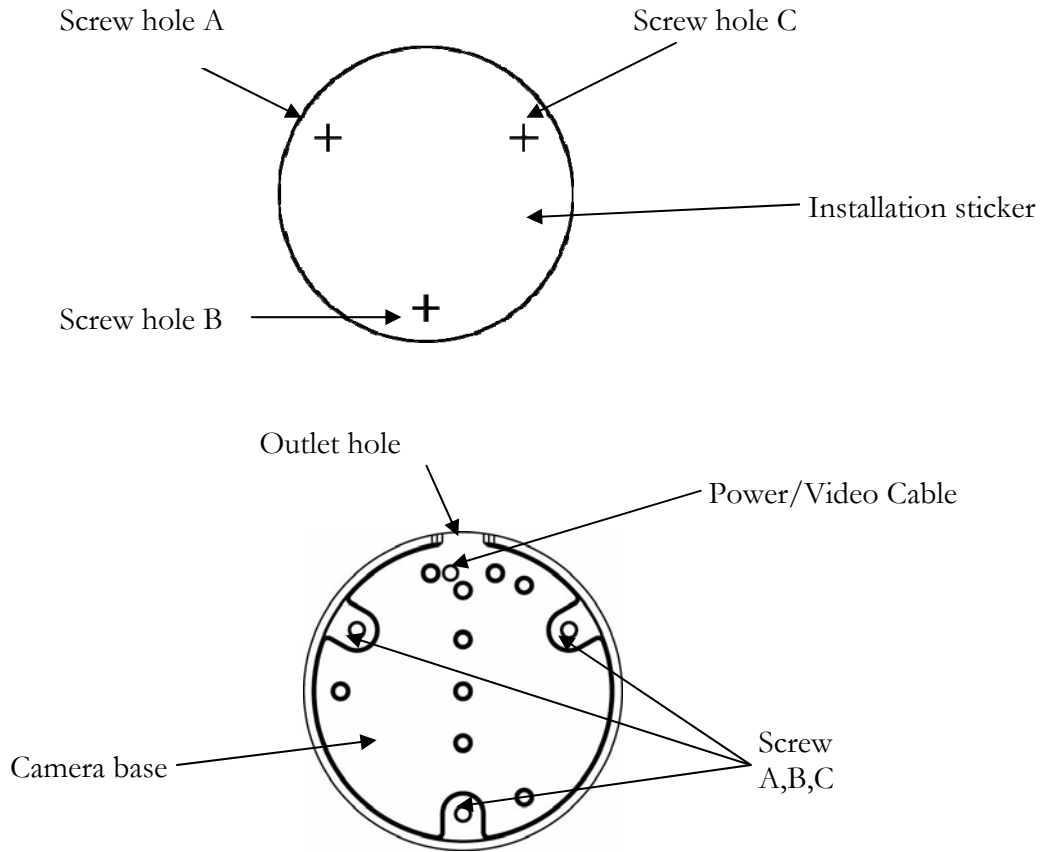

3. Pull the cables to be connected to power and video cables from ceiling or wall.

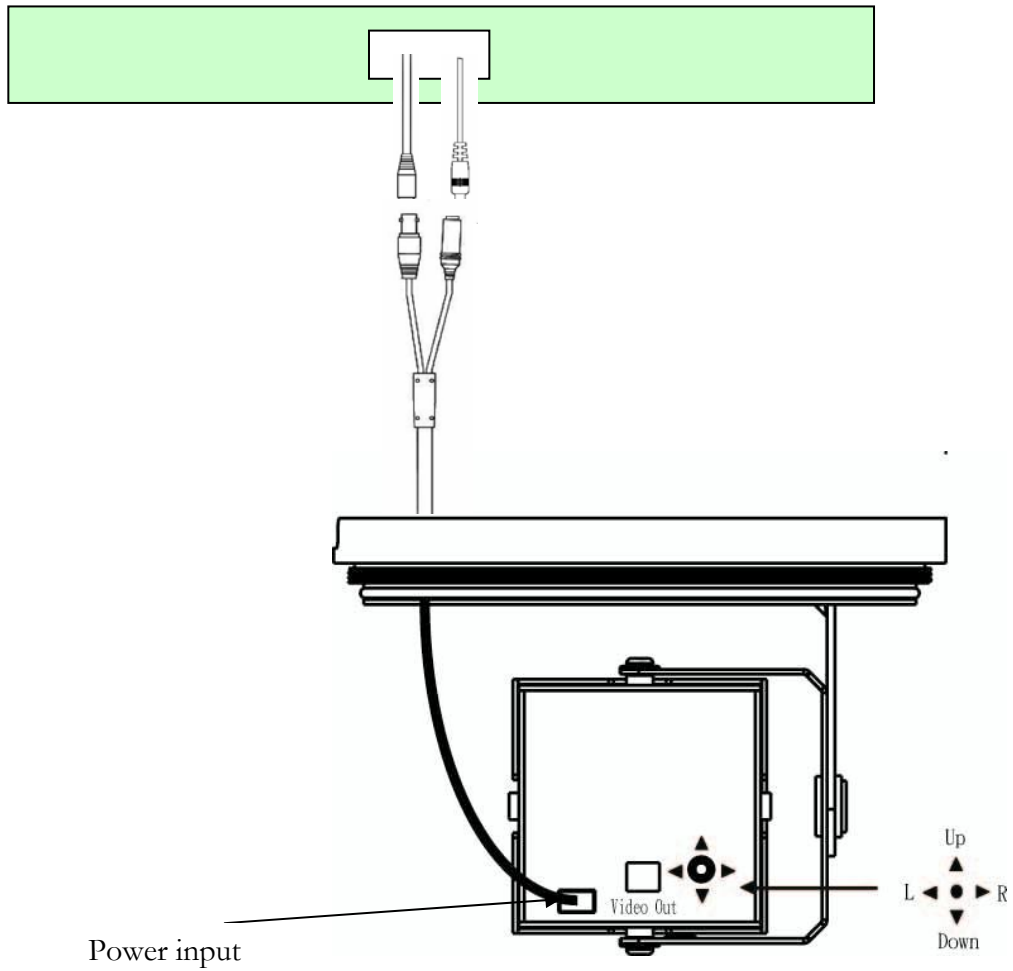

2.1.2 Mounting

1. Take off camera's cover.

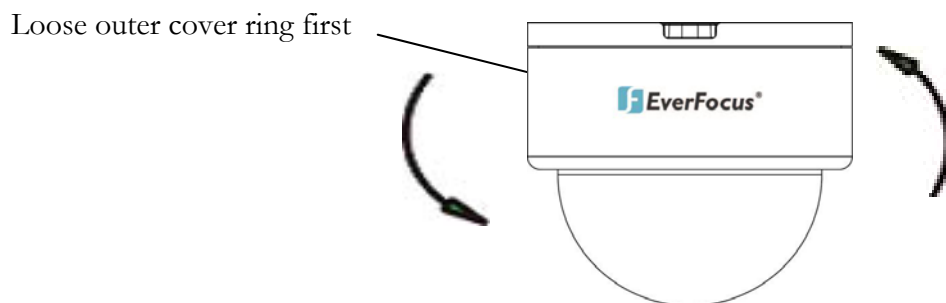

- Take off camera's cover.

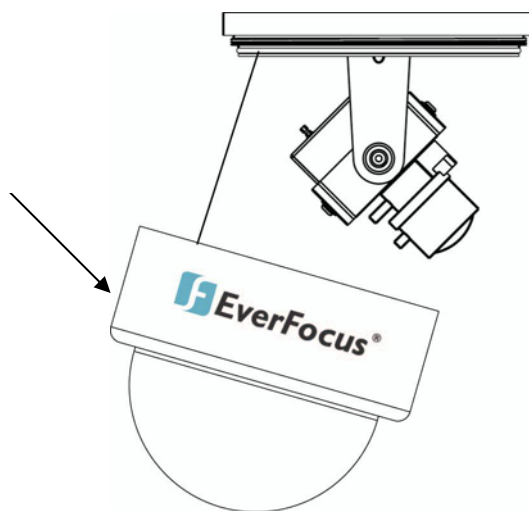

2. Fix the camera base to ceiling or wall by using 3 screws.

Ceiling Mount:

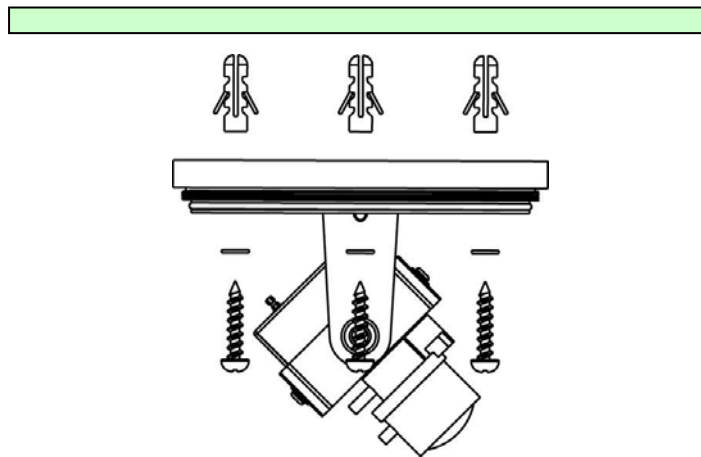

Wall Mount:

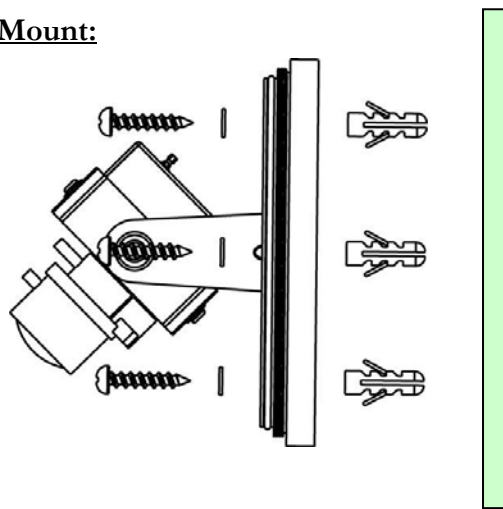

2.2 Adjusting Camera

2.2.1 Adjusting Camera Position

Adjust the camera to best angle for viewing.

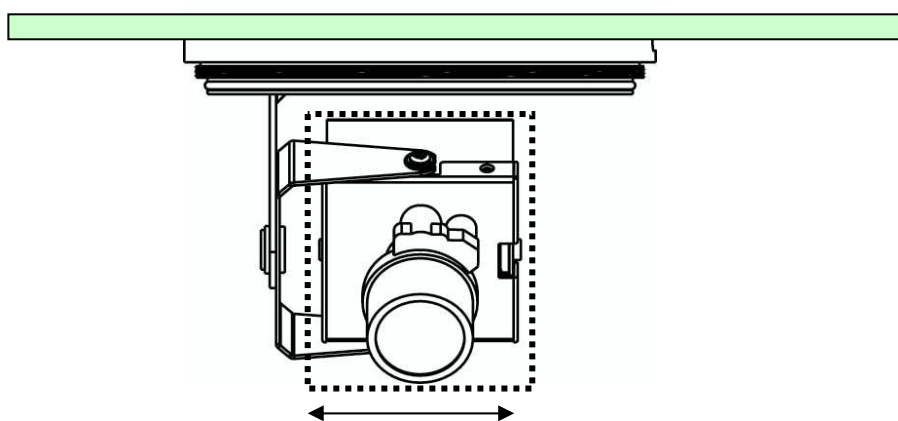
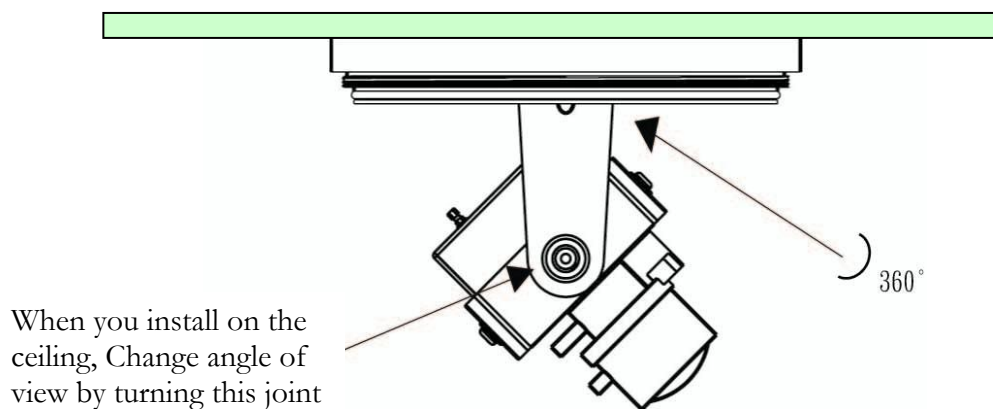

2.2.2 Adjusting Zoom and Focus

It is highly recommended to use Everfocus Test Monitor to test the camera. Find the second Video testing connection at back panel. Connect it with video cable in the package.

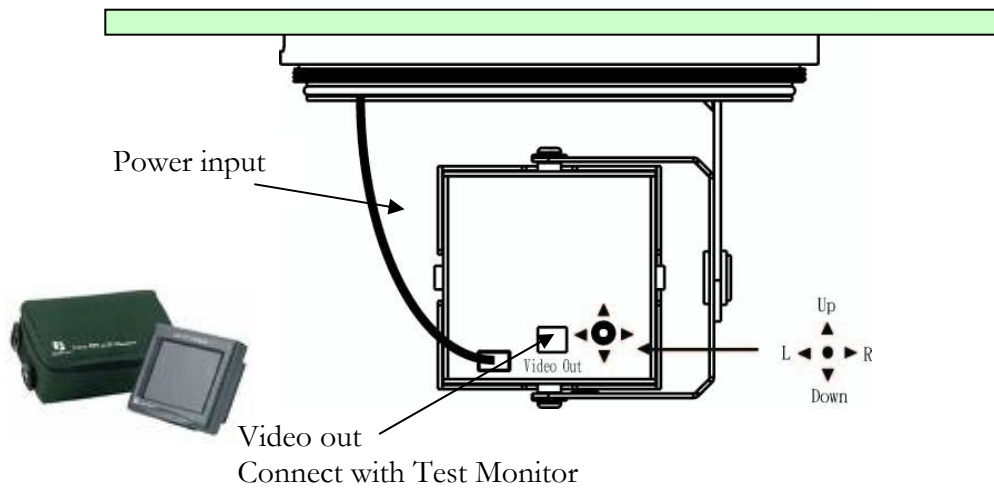

1. Loosen the zoom ring knob, and then turn the ring towards <W> or <T> as necessary to obtain the desired view range.
 W side (Zoom out)
 The viewing range will be wider and the subject is smaller.
 T side (Zoom in)
 The viewing range will be smaller and the subject is larger.
2. Loosen the focus ring knob, then turn the ring towards <∞> or <N> as necessary to obtain the clear video image.
3. Repeat steps 1 and 2 until the best image is obtained. Once the lens setting is finished, tighten the zoom ring and the focus ring knobs.

Important Note when focusing a 9-22mm Lens

To adjust lens zoom and focus, if using the 9~22mm lens model of ED560 series cameras, the focus aiding lens cap must be used to simulate the dome being closed. Follow the steps below to ensure that camera will stay in focus.

Step 1 Take the included focus aiding lens cap (shown below) from its small plastic bag.



Step 2 Open dome cover and place the Focus aiding lens cap on the lens making sure that the caps notch is resting on the zoom knob.



Step3 With cap on, adjust the focus and zoom rings by loosening the knobs and turning the rings until subject is in focus. Retighten the knobs when done.



Step4 When finished adjusting focus and zoom, remove the focus aiding cap from the camera lens, replace the the dome cover and tighten the tamperproof screws with provided wrench.

NOTE: If necessary, you can put desiccant pack in bracket side. Using cable to fix it before place the cover back to camera.

Desiccant Pack

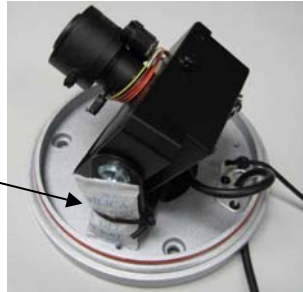

2.2.3 Camera Setting

2.2.3.1 OSD User Setup Menu

This camera utilizes an On Screen Display (OSD) user setup menu.

Please refer to Chapter 3 OSD Menu & Configuration, to get more detail about OSD menu steps.

2.2.4 Close the Camera Cover

ED560 is specially designed with one inner cover and one outer cover ring for water-proof and user-friendly installation purpose. Please follow the instruction for closing the camera cover.

1. Aim the lens to window of cover.



2. Push the interior cover until it completely covers the whole red gasket and line up with camera base parallel. The cover need to align with camera base otherwise it cannot be closed. Then tighten the outer cover ring tightly to the camera base.

Push the inner cover and cover the whole red gasket



Outer cover ring

Correct



Wrong (not aligned)



**Wrong (red gasket
not covered)**



3. If the lens did not aim the window. Slightly adjust the inner cover to have the lens aimed exactly at window.

Slightly adjust the cover



4. Tighten the outer cover ring until it is firmly fixed.

Turn the external ring



OSD Menu & Configuration

This chapter introduces how to configure the camera OSD menu.

STEPS

1. Configure the camera, please refer to OSD Menu Setup

3.1 OSD Menu Setup

Please make sure control key selection switch is at **OSD** position.

Note: OSD menu only requires one click and you should see the following menu.

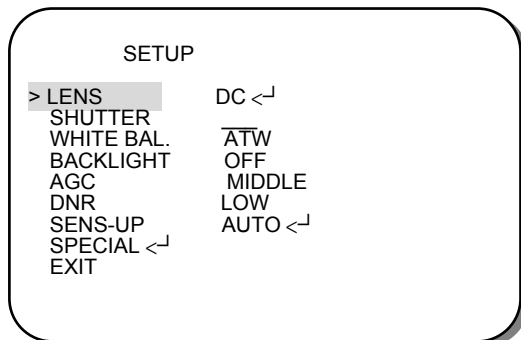

3.1.1 LENS

1. When the SETUP menu is displayed on the screen, please direct the arrow to point to “LENS” by turning the mini-joystick UP (▲) or DOWN (▼). Press the mini-joystick to adjust IRIS level (the higher is brighter). In most cases, you don't need to adjust this, since Lens is Auto Iris supported.

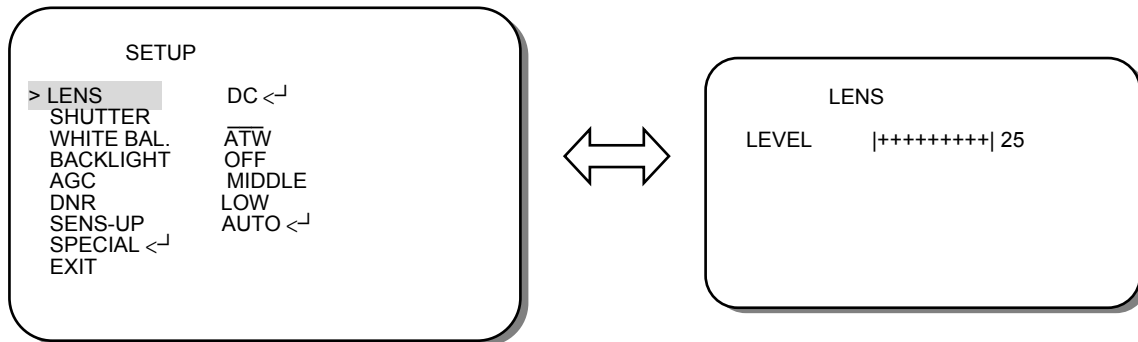

NOTE: Since DC lens is a built-in lens for EZ550 camera, it does not support Manual lens, please do not select lens as Manual mode, it disables sens-up and may cause malfunction of lens.

2. Please press the mini-joystick for saving setting and return to the previous menu.

3.1.2 Shutter

1. When the SETUP menu is displayed on the screen, please direct the arrow to point to “SHUTTER” by turning the mini-joystick DOWN (▼).
2. Select the shutter mode by turning the mini-joystick LEFT (◀) or RIGHT (▶).
Three modes are available. FLK, ESC and Manual.

NOTE:

Since DC lens is a built-in lens for EZ550 camera, shutter does not support ESC and Manual functions. ESC and Manual are reserved functions, please do not select these two options in normal situation.

⇒ FLK: Please select “FLK” mode when flickering occurs on the screen, which is caused by an irregular balance between illumination and frequency. NTSC model: 1/100, PAL model: 1/120.

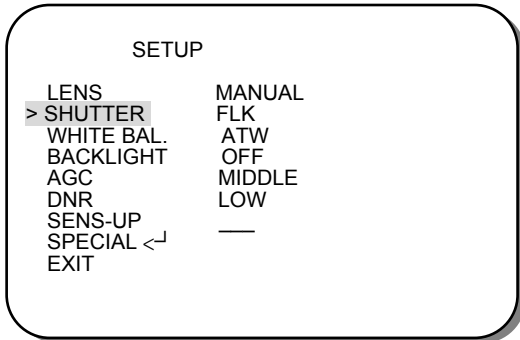

⇒ ESC (Reserved).

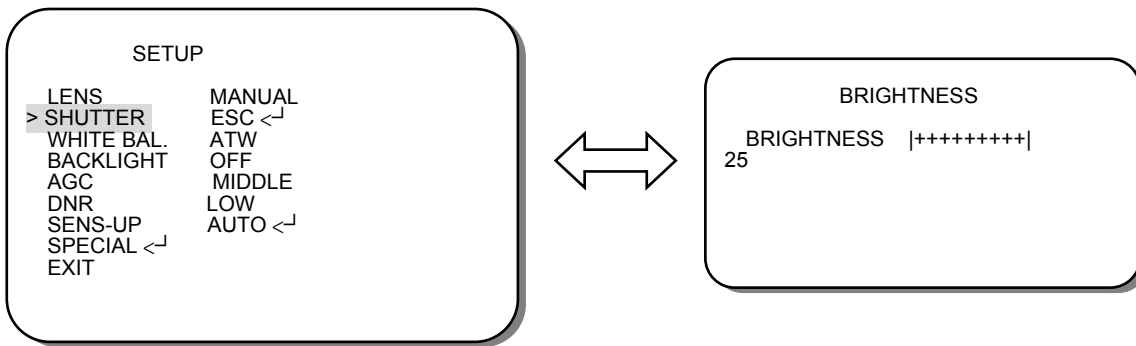

⇒ Manual (Reserved).

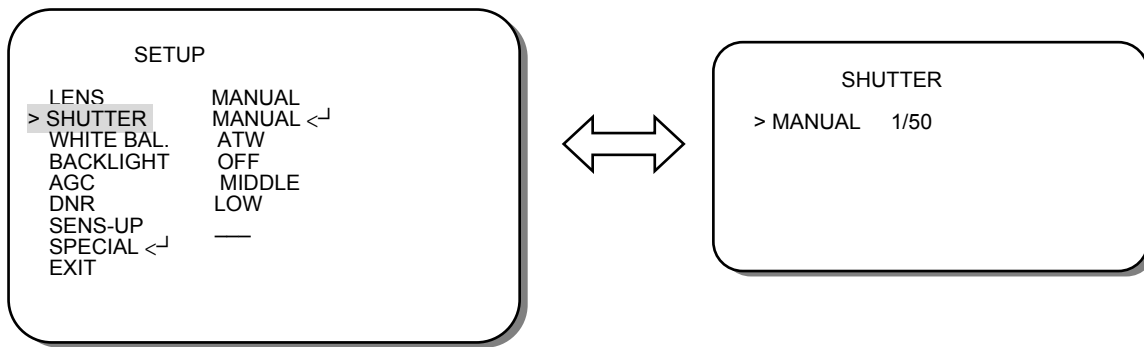

3. Press the mini-joystick when you finish all the settings.

NOTE:

① With DC lens, the shutter speed is fixed as 1/60 for NTSC and 1/50 for PAL.

3.1.3 White Balance Control

The screen color can be adjusted by using the WHITE BALANCE function.

1. Please direct the arrow to point to “WHITE BAL” on the SETUP menu by turning the mini-joystick UP (▲) or DOWN (▼).
2. Please select the mode you would like to operate by turning the mini- joystick LEFT (◀) or RIGHT (▶).

Please select one of the 3 modes below:

- ⇒ ATW (Auto Tracking White Balance): This mode can be used within the color temperature range from 2,500°K to 8,300°K (eg, fluorescent light, outdoor, sodium vapor lamp or inside tunnels).
- ⇒ AWC (Auto White Balance Control): Press mini-joystick while the camera is directed at a piece of white paper to get the optimum state under the present illumination. If the environment and the light source are changed, you need to adjust the white balance again.
- ⇒ MANUAL: The manual adjustment mode enables a more precise adjustment. Please select ATW or AWC first. Then change to manual adjustment mode and press mini-joystick. Set the suitable color temperature, and increase or decrease the red and blue color values at the same time while checking the color changes of the object.

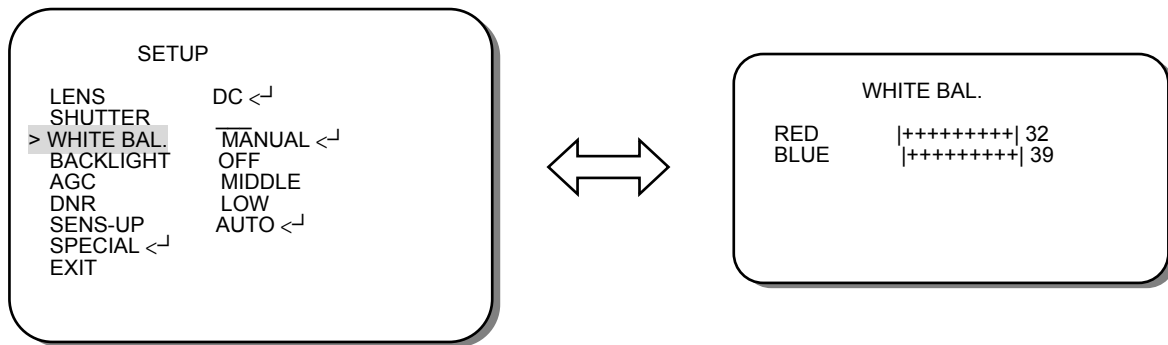
**NOTE:**

Under the following conditions, the WHITE BALANCE function may not operate well. In such cases, please select the AWC mode.

- ① When the object's surroundings have a high color temperature.
- ② When the object's surroundings are dark.
- ③ If the camera faces a fluorescent light directly or is installed in a place where the illumination changes constantly, the WHITE BALANCE function may become unstable.

3.1.4 BACKLIHGT

Even there is a massive backlight behind the object, bright images of the background and the object can still be obtained by using the BACKLIGHT function.

1. Please direct the arrow to point to "BACKLIGHT" on the SETUP menu by turning the mini-joystick UP (▲) or DOWN (▼).
2. Select the mode you would like to operate by turning the mini-joystick LEFT (◀) or RIGHT (▶).

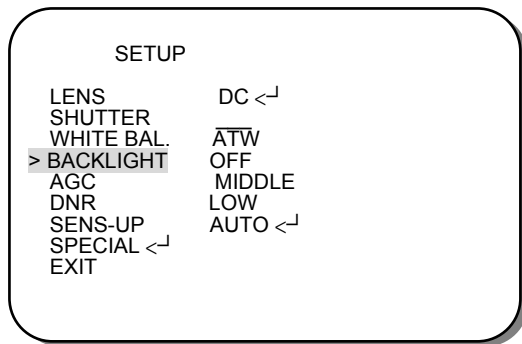

- ⇒ HIGH: The gain increases from 0dB up to 42dB.
- ⇒ MIDDLE: The gain increases from 0dB up to 30dB.
- ⇒ LOW: The gain increases from 0dB up to 18dB.
- ⇒ OFF: BACKLIGHT function does not operate.

3.1.5 AGC (Auto Gain Control)

1. Please direct the arrow to point to “AGC” on the SETUP menu by turning the mini-joystick UP (▲) or DOWN (▼).
2. Select the mode you would like to operate by turning the mini-joystick LEFT (◀) or RIGHT (▶).
The more the level of gain increases, the brighter the screen and the level of noise increases as well.
 - ⇒ HIGH: The gain increases from 6dB up to 42dB.
 - ⇒ MIDDLE: The gain increases from 6dB up to 30dB.
 - ⇒ LOW: The gain increases from 6dB up to 18dB.
 - ⇒ OFF: The gain is fixed at 6dB.

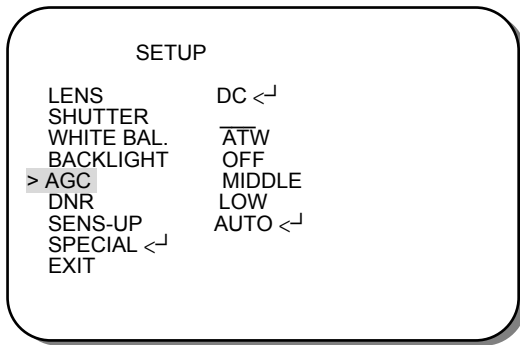

3.1.6 DNR (Dynamic Noise Reduction)

Dynamic Noise Reduction in video images has the following effects.

1. Images are brighter and sharper.
2. When the level of noise is reduced, the performance of a camera can apparently be improved.
3. When it is recorded digitally, reduced noise can reduce image file size.

As the level of gain changes, the background noise in the low light level automatically decreases.

1. Please direct the arrow to point to “DNR” on the SETUP menu by turning the mini-joystick UP (▲) or DOWN (▼).
2. Select the mode you would like to operate by turning the mini-joystick LEFT (◀) or RIGHT (▶).

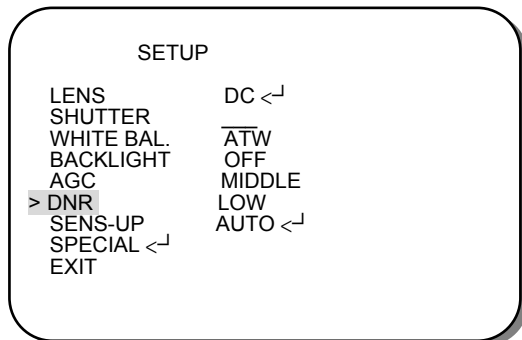

- ⇒ OFF: No reduction in noise level.
- ⇒ LOW: Little reduction in noise level with nearly no ghost image. Default value is LOW.
- ⇒ MIDDLE: Just enough reduction in noise levels without causing much ghost imaging.
- ⇒ HIGH: Huge reduction in noise level, which may cause much ghost imaging.

NOTE:

When AGC is turned off, DNR will be disabled.

3.1.7 SENS-UP

SENS UP is used to keep a brilliant, vivid screen image by automatically detecting changes in the level of light under low light level conditions. The value is from x2 ~x128.

1. Please direct the arrow to point to “SENS UP” on the SETUP menu by turning the mini-joystick UP (▲) or DOWN (▼).
2. Select the mode you would like to operate by turning the mini-joystick LEFT (◀) or RIGHT (▶).
 - ⇒ AUTO: Low light level auto mode. Default value is AUTO (Up to X 10).

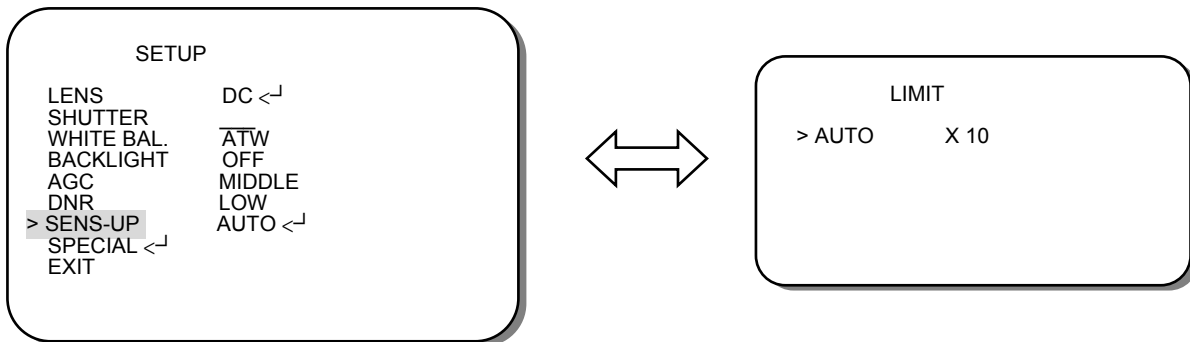

3. Press the mini-joystick when you finish all the settings.

NOTE:

- ① The maximum storage magnification in low light level movement situations can be adjusted by pressing the mini-joystick in “AUTO” mode.
- ② The screen becomes brighter when the magnification increases; yet the after image increases as well.
- ③ Please be noted that spots and noise may appear if storage magnification increases when SENS-UP is operating. This is a normal phenomenon.

3.1.8 SPECIAL

1. Please direct the arrow to point to “SPECIAL” on the SETUP menu by turning the mini-joystick UP (▲) or DOWN (▼).

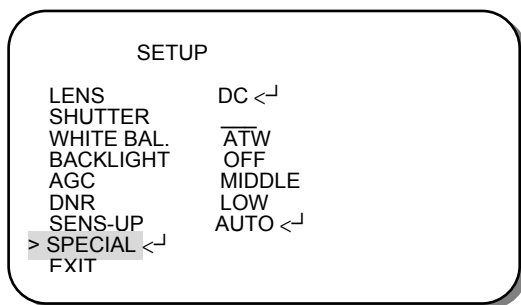

2. Select the mode you would like to operate by turning the mini-joystick LEFT (◀) or RIGHT (▶).

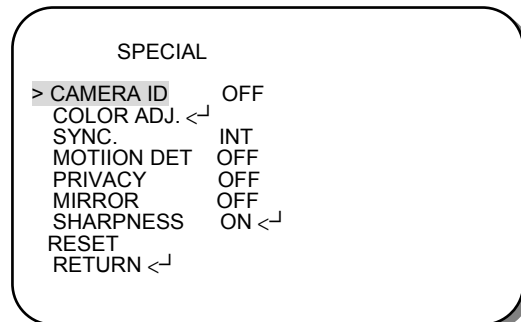

3.1.8.1 CAMERA ID

Input the camera ID, and it will be appeared on the monitor.

- 1) Please direct the arrow to point to “CAMERA” by turning the mini-joystick UP (▲) or DOWN (▼).
- 2) Select “ON” by turning the mini-joystick LEFT (◀) or RIGHT (▶).
- 3) Press the mini-joystick.
- 4) Maximum 15 letters can be used for the ID.
 - Turning the mini-joystick UP (▲), DOWN (▼), LEFT (◀) or RIGHT (▶) to select the letters.
 - Press the mini-joystick to lock in the letters.
- 5) Once a name has been selected, please choose a position where you would like to display the name.
 - Move the cursor onto “POS” and press the mini-joystick.
 - The name will appear at the top left hand corner.
 - Please use the 4 directional buttons to find the desired position to display the name.
- 6) If you would like to cancel the ID inputted, please move the cursor to “CLR”, and all the letters inputted will be deleted.
- 7) Select “END” and press the mini-joystick to complete ID input.

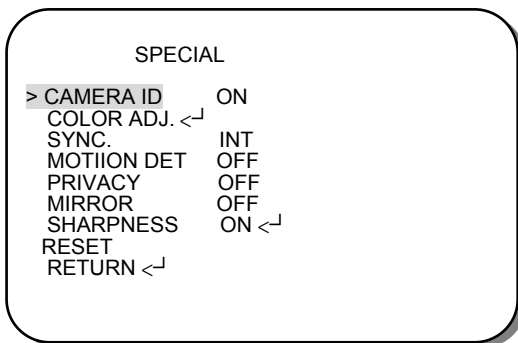

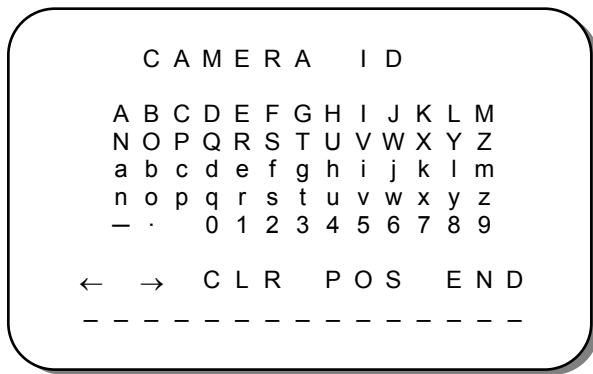

3.1.8.2 COLOR ADJ

Adjust the Color Gain from 0 ~ 15

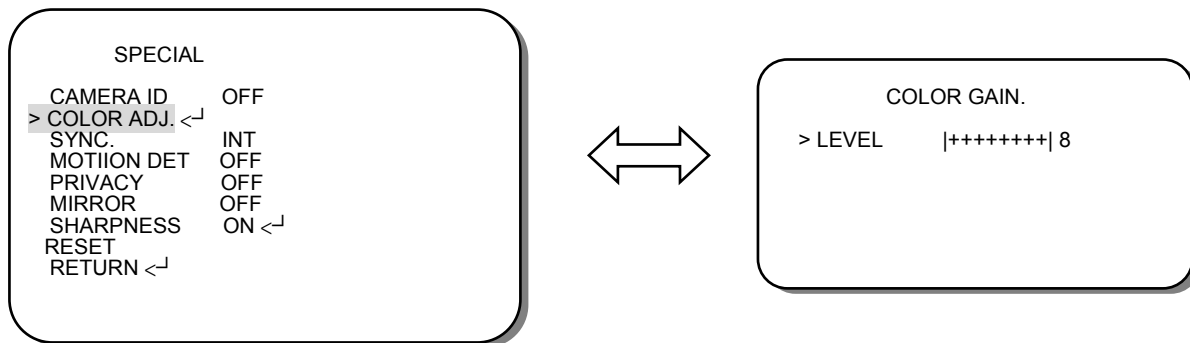

3.1.8.3 SYNC

There are two SYNCHRONIZATION modes: INTERNAL and EXTERNAL LINE-LOCK. In LINE-LOCK mode, without a synchronous generator, it synchronizes the video signal between cameras. The Line-Lock synchronization is only used in the places of 60Hz (NTSC models) or 50Hz (PAL models).

-INT: Internal synchronization

-LL: External line-lock synchronization

=> If you choose “LL”, you can adjust the phase you wish to set. Then press the mini-joystick. You can adjust the phase you wish to set from 0 to 359.

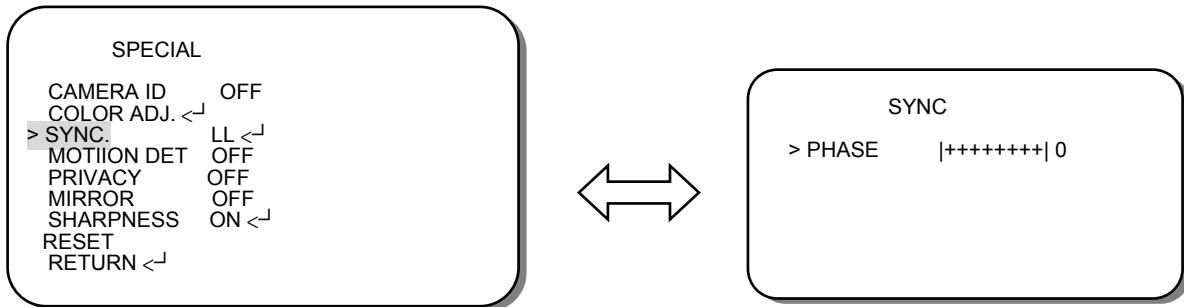

3.1.8.4 MOTION DETECTION

EZ550 enables you to observe movements of objects in 4 different places on the screen, the message “MOTION DETECTED” appears on the screen when movement is detected; therefore this helps to improve supervision efficiency. The camera detects an object’s movement by sensing discrepancy of outline.

- 1) Please direct the arrow to point to “MOTION DET” by turning the mini-joystick UP (▲) or DOWN (▼).
- 2) Select “ON” by turning the mini-joystick LEFT (◀) or RIGHT (▶).
- 3) Press the mini-joystick.

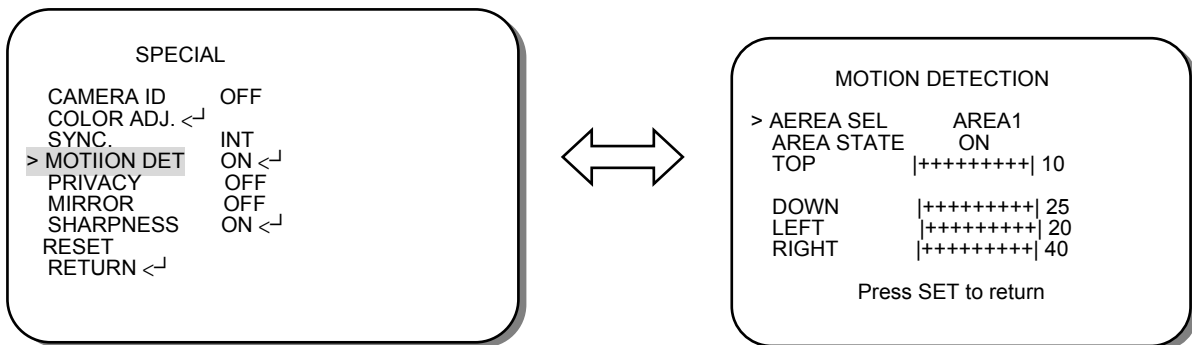

- Please select the area you would like to detect from the 4 areas in AREA SEL mode.
- Please select ON mode for the chosen area.

- Please turn mini-joystick UP (▲) or DOWN (▼) to move between 'TOP, DOWN, LEFT' and 'RIGHT' for adjusting the size of the area.
- Please turn mini-joystick LEFT (◀) or RIGHT (▶) to adjust the value for size of the area.

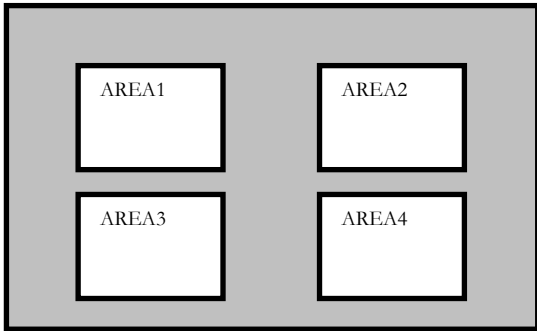

- Additionally, it is possible to change the position of the area. Please refer to the following example for detailed steps on moving AREA1 to center.

1. The original position of AREA1 was 'TOP: 10, DOWN: 25, LEFT: 20 and RIGHT: 40.

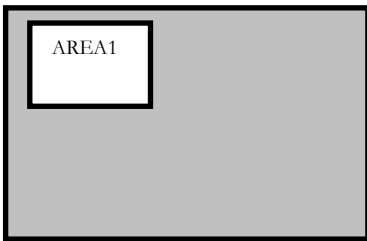

2. Increase DOWN scale value by 20. AREA1 position after change is: TOP: 10, DOWN: 45, LEFT: 20 and RIGHT: 40.

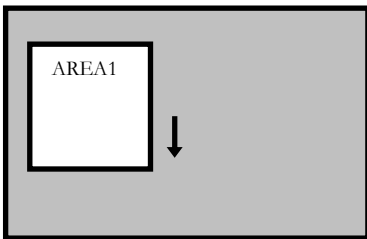

3. Increase TOP scale value by 20. AREA1 position after change is: TOP: 30, DOWN: 45, LEFT: 20 and RIGHT: 40.

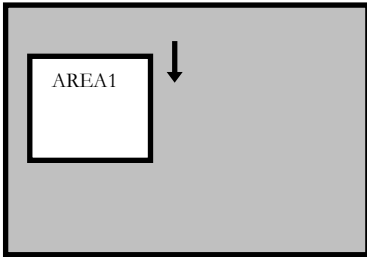

4. Increase RIGHT scale value by 20. AREA1 position after change is: TOP: 30, DOWN: 45, LEFT: 20 and RIGHT: 60.

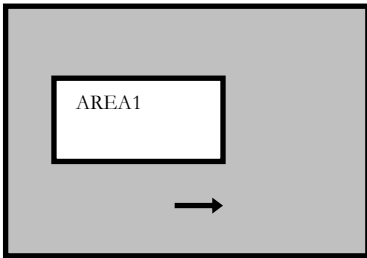

Increase LEFT scale value by 20. AREA1 position after change is: TOP: 30, DOWN: 45, LEFT: 40 and RIGHT: 60.

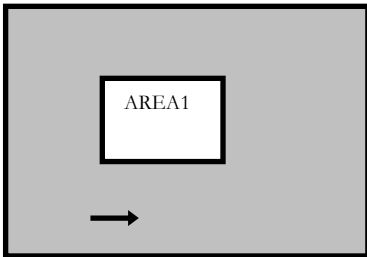

- In order to save the changes and complete the setting, press the mini-joystick. This allows you to return to the previous menu.

3.1.8.5 PRIVACY

This mode covers the areas you do not want to see on the screen.

- 1) Please direct the arrow to point to "PRIVACY" by turning the mini-joystick UP (▲) or DOWN (▼).
- 2) Select "ON" by turning the mini-joystick LEFT (◀) or RIGHT (▶).
- 3) Press the mini-joystick.

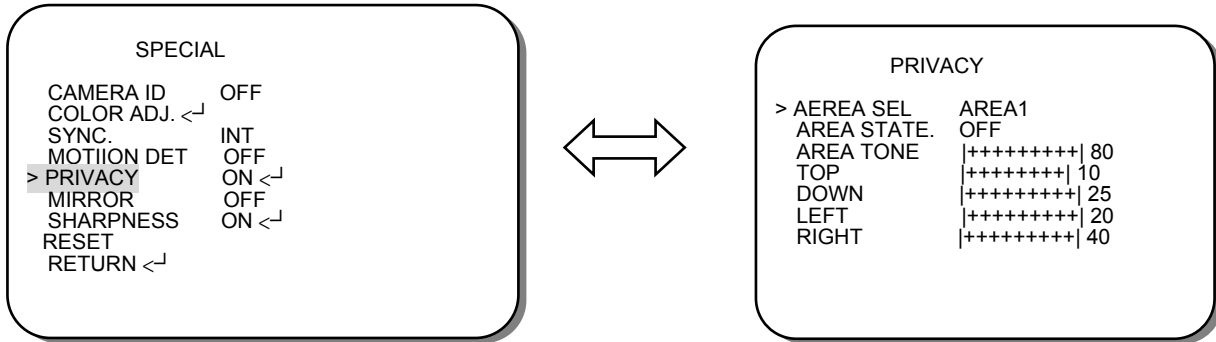

- Please select the area you would like to cover from the 4 areas in AREA SEL mode.
- Please select ON mode for the chosen area.
- Please select AREA TONE for cover area color. The smaller the number, the darker the color.
- Please turn the mini-joystick UP (▲) or DOWN (▼) to move between TOP, DOWN, LEFT and RIGHT for adjusting the size of the area to be covered.
- Please turn the mini-joystick LEFT (◀) or RIGHT (▶) to adjust the value for size of the area to be covered.

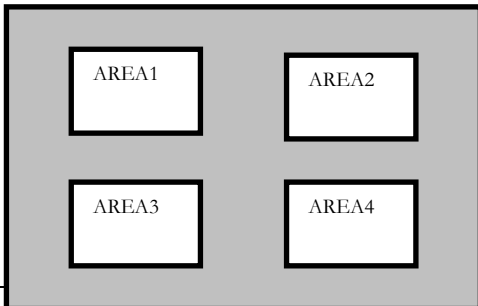

- Additionally, it is possible to change the position of the area to be covered. Please refer to the following example for detailed steps on moving AREA1 to center.

1. The original position of AREA1 was TOP: 10, DOWN: 25, LEFT: 20 and RIGHT: 40.

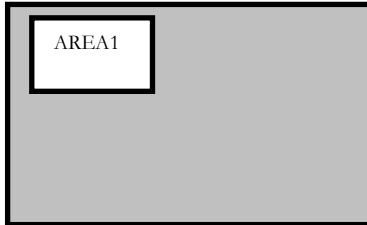

2. Increase DOWN scale value by 20. AREA1 position after change is: TOP: 10, DOWN: 45, LEFT: 20 and RIGHT: 40.

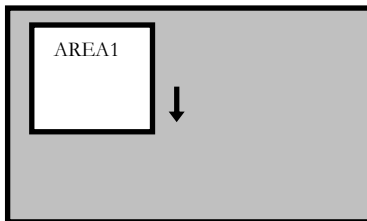

3. Increase TOP scale value by 20. AREA1 position after change is: TOP: 30, DOWN: 45, LEFT: 20 and RIGHT: 40.

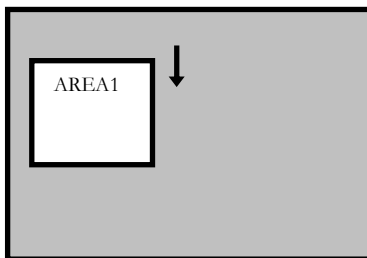

4. Increase RIGHT scale value by 20. AREA1 position after change is: TOP: 30, DOWN: 45, LEFT: 20 and RIGHT: 60.

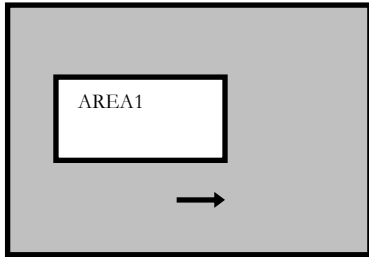

5. Increase LEFT scale value by 20. AREA1 position after change is: TOP: 30, DOWN: 45, LEFT: 40 and RIGHT: 60.

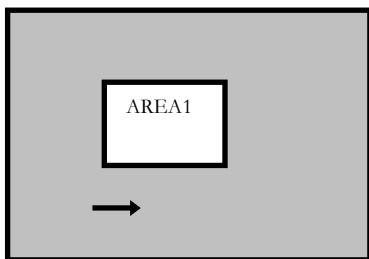

- In order to save the changes and complete the setting, press the mini-joystick. This allows you to return to the previous menu.

3.1.8.6 MIRROR

- ON: Sets a horizontal image 180 angle inversion.
- OFF: Disable the inversion.

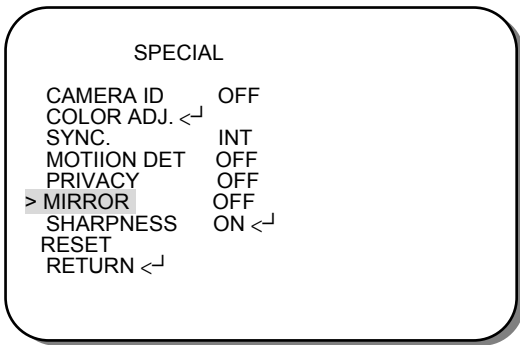

3.1.8.7 SHARPNESS

The contour of the video image becomes cleaner and more distinguishing as the level of SHARPNESS increases. If the level goes up extremely, it may affect the video image and cause noise.

- ON: Enable the SHARPNESS mode.
- OFF: Disable the SHARPNESS mode.
 - Please press the mini-joystick.
 - The available range of level is 0~31.

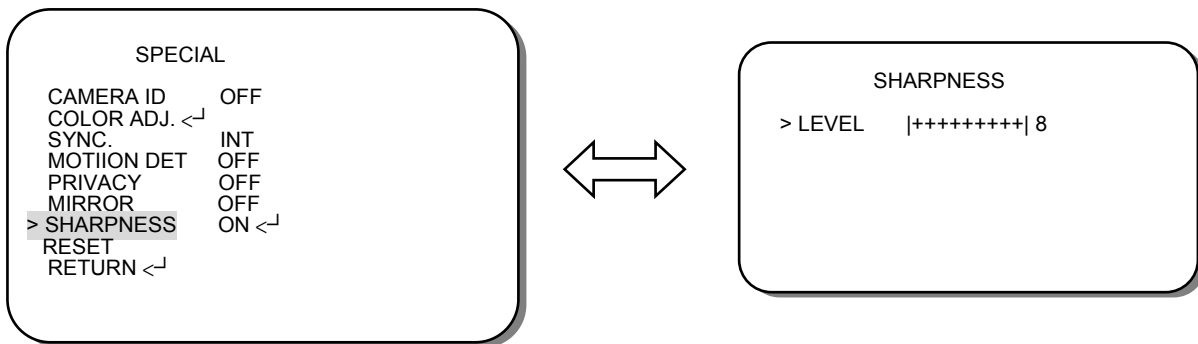

3.1.8.8 RESET

Press the mini-joystick on RESET for 3 seconds until it restarts. It will go to factory default value.

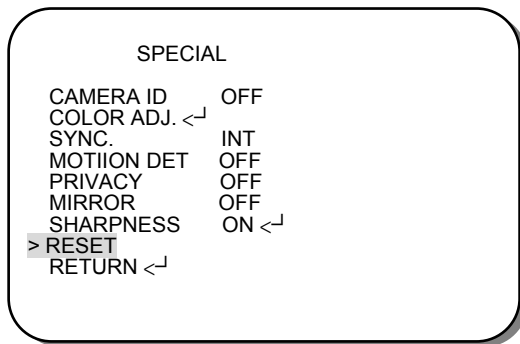

3.1.8.9 RETURN

Press the mini-joystick on RETURN. It saves all settings in SPECIAL menu and returns to the Setup menu.

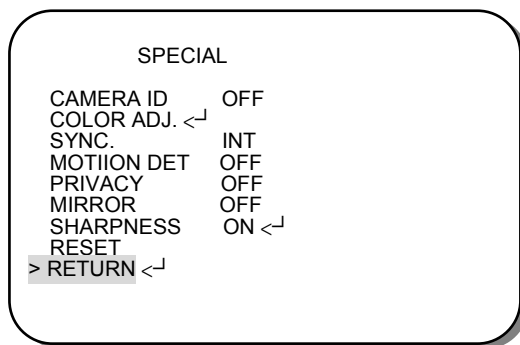

3.1.9 EXIT

Press the mini-joystick on EXIT after you finish all the settings. It will return to live image.

NOTE:

If you quit the Menu without pressing EXIT, all the settings you previously did will NOT be saved.

EverFocus Electronics Corp.

Head Office:

12F, No.79 Sec. 1 Shin-Tai Wu Road,
Hsi-Chih, Taipei, Taiwan
TEL: +886-2-26982334
FAX: +886-2-26982380
www.everfocus.com.tw

USA L.A. Office:

1801 Highland Ave. Unit A
Duarte, CA 91010, U.S.A.
TEL: +1-626-844-8888
FAX: +1-626-844-8838
www.everfocus.com

USA N.Y. Office:

415 Oser Avenue Unit S
Hauppauge, NY 11788
TEL: 631-436-5070
FAX: 631-436-5027
www.everfocus.com

Europe Office:

Albert-Einstein-Strasse 1
D-46446 Emmerich, Germany
TEL: 49-2822-9394-0
www.everfocus.de

China Office:

Room 609, Technology Trade Building,
Shangdi Information Industry Base,
Haidian District, Beijing, China 10085
TEL: +86-10-62973336/37/38/39
FAX: +86-10-62971423
www.everfocus.com.cn

Japan Office:

1809 WBG MARIBU East 18F,
2-6 Nakase.Mihama-ku.
Chiba city 261-7118, Japan
TEL: +81-43-212-8188
FAX: +81-43-297-0081
www.everfocus.com

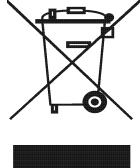
	<p>Your EverFocus product is designed and manufactured with high quality materials and components which can be recycled and reused.</p> <p>This symbol means that electrical and electronic equipment, at their end-of-life, should be disposed of separately from your household waste.</p> <p>Please, dispose of this equipment at your local community waste collection/recycling centre.</p> <p>In the European Union there are separate collection systems for used electrical and electronic product.</p> <p>Please, help us to conserve the environment we live in!</p>	<p>Ihr EverFocus Produkt wurde entwickelt und hergestellt mit qualitativ hochwertigen Materialien und Komponenten, die recycelt und wieder verwendet werden können.</p> <p>Dieses Symbol bedeutet, dass elektrische und elektronische Geräte am Ende ihrer Nutzungsdauer vom Hausmüll getrennt entsorgt werden sollen.</p> <p>Bitte entsorgen Sie dieses Gerät bei Ihrer örtlichen kommunalen Sammelstelle oder im Recycling Centre.</p> <p>Helpen Sie uns bitte, die Umwelt zu erhalten, in der wir leben!</p>
---	--	---



P/N: MED5G00600_Ver.B

Free Manuals Download Website

<http://myh66.com>

<http://usermanuals.us>

<http://www.somanuals.com>

<http://www.4manuals.cc>

<http://www.manual-lib.com>

<http://www.404manual.com>

<http://www.luxmanual.com>

<http://aubethermostatmanual.com>

Golf course search by state

<http://golfingnear.com>

Email search by domain

<http://emailbydomain.com>

Auto manuals search

<http://auto.somanuals.com>

TV manuals search

<http://tv.somanuals.com>