



EverFocus[®]

2 Megapixel Full HD-CCTV Camera

Operation Instructions

Model No. **EQH5200**

Please read this manual first for correct installation and operation. This manual should be retained for future reference. The information in this manual was current when published. The manufacturer reserves the right to revise and improve its products. All specifications are therefore subject to change without notice.

PRECAUTIONS

- 1. Do not install the camera near electric or magnetic fields.**
Install the camera away from TV/radio transmitters, magnets, electric motors, transformers and audio speakers since the electromagnetic fields generated from these devices may distort the video image.
- 2. Never disassemble the camera beyond the recommendations in this manual nor introduce materials other than those recommended herein.**
Improper disassembly or introduction of corrosive materials may result in equipment failure or other damage.
- 3. Try and avoid facing the camera toward the sun.**
In some circumstances, direct sunlight may cause permanent damage to the sensor and/or internal circuits.
- 4. Keep the power cord away from water and other liquids and never touch the power cord with wet hands.**
Touching a wet power cord with hands or touching the power cord with wet hands may result in electric shock.
- 5. Never install the camera in areas exposed to water, oil or gas.**
Water, oil or gas may result in equipment failure, electric shock or, in extreme cases, fire.
- 6. Cleaning**
Do not touch the surface of the sensor directly with the hands. Use a damp soft cloth to remove any dirt from the camera body. Use lens tissue or a cotton tipped applicator and ethanol to clean the sensor and the camera lens. Please do not use complex solvents, corrosive or abrasive agents for cleaning.
- 7. Do not operate the camera beyond the specified temperature, humidity or power source ratings.**
Use the camera at temperatures within 0°C ~ 45°C (32°F~113°F) and humidity between 20~80%. The input power source is 12VDC/24VAC.

TABLE OF CONTENTS

1. PRODUCT OVERVIEW	2
1.1 Main Features	2
1.2 Package Contents	2
1.3 Specifications	3
1.4 Dimensions	3
2. NAMES AND FUNCTIONS OF PARTS	4
2.1 Front panel.....	4
2.2 Top/Bottom Mounting	4
2.3 Back panel and connections	5
3. INSTALLATION	6
4. OSD Menu & Configuration	7
4.1 Exposure	10
4.1.1 Lens	10
4.1.2 Shutter	10
4.1.3 Iris	10
4.1.4 AGC (Auto Gain Control – basic low light signal amplification)	10
4.1.5 BLC	10
4.1.6 Anti-Flicker	11
4.2 White Balance Control.....	11
4.3 Day/Night.....	11
4.4 Special.....	12
4.4.1 Resolution	12
4.4.2 Camera Title	12
4.4.3 D-Effect.....	12
4.4.4 TV standard.....	13
4.4.5 Language	13
4.4.6 Default	13
4.5 Image Adjust	13
4.5.1 Sharpness	13
4.5.2 Brightness	13
4.5.3 Contrast	13

1. PRODUCT OVERVIEW

Deliver 2 megapixel full HD 1080i quality digital images over standard coaxial cable with the EQH5200! Wire new megapixel systems with familiar and easy to install coax and BNC connectors, or reuse the existing coax cable infrastructure to efficiently upgrade analog systems to megapixel digital performance without the need to design and deploy an IP network. Enjoy true plug-and-play: each home run coaxial cable provides a full bandwidth dedicated communications path for the HD-SDI/HD-CCTV standards compliant signal; no addressing is required to capture full 1080i HD real time video, without congestion, latency or distortion. Easy to install and test, the EQH5200 has a TV output at the back of the camera to connect a standard portable test monitor for convenient aim and focus.

The EQH5200 is based on a 1/2.5" 2 megapixel progressive scan sensor for full HD images, with field selectable choice of 1080i resolution output, or 720p resolution to conserve DVR hard disk space. With dual voltage (12VDC/24VAC) operation, true day/night operation, and a flexible choice of megapixel lenses to achieve the desired field of view, the EQH5200 is the right choice to deploy HD-CCTV video surveillance.

1.1 Main Features

- HD-CCTV 2 Megapixel real time 1080i HD video over coax
- 2 megapixel progressive scan CMOS sensor
- Supports video outputs of 720p and 1080i
- Lens Types: supports DC and manual iris lenses, CS mount (C mount adapter ring included)
- True day/night mode selectable with automatic ICR module
- Easy to use OSD setup menu
- Dual Video Output : Megapixel HD-SDI (BNC) plus SD TV Out (RCA) for installation
- Dual Power Source 12VDC/24VAC dual voltage

1.2 Package Contents

1. Camera unit
2. User's manual
3. ND filter
4. Accessory pack containing
 - i. 5mm spacer C/CS Lens adapter
 - ii. ¼-20 UNC thread mounting bracket and (2) screws
 - iii. Allen key to for lens back focus set screw
 - iv. Lens control voltage connector

1.3 Specifications

Pickup Device	1/2.5" 2 megapixel CMOS sensor
Sensitivity	0.02lux/F=1.2(AGC ON)
S/N Ratio	Greater than 50dB (AGC off)
Video Format Main Output	HD-SDI/HD-CCTV
Resolution Main Output	1920x1080/2 Megapixel/1080i or 1280x720/1 Megapixel/720p
Video Mode Main Output	Field select 1080i or 720p
Main Output Connector	BNC-F
Video Format Test Output	NTSC/PAL selectable 1V p-p
Test Output Connector	RCA-F
Electronic Shutter	1/60(1/50)~1/8000
Lens Type	CS mount (Adapter included for C-mount; lens sold separately).
Lens Control	Supports DC or manual lens
Back Light Comp.	On/Off selectable
Auto Gain Control	High/Middle/Low/Off selectable
Auto White Balance	AWB/One Push WB/Manual WB/Indoor/Outdoor
Gamma Correction	0.45 nominal, adjustable 0.05~1.00
Iris Control	Auto, -2.0EV~2.0EV
OSD Menu	Yes (controlled from rear 5-axis joystick control)
True Day/Night Control	Yes (Auto IR cut filter removal)
H-Mirror	Yes
Power Source	12VDC/24VAC
Power Consumption	24VAC: 6W max. 12VDC: 6W max.
Dimensions (incl. BNC)	68mm(W) x 56mm(H) x 146mm(D) ; 2.7"(W) x 2.2"(H) x 5.7"(D)
Weight	0.4 kg ; 0.9 lbs
Operating Temperature	0°C~45°C ; 32°F~113°F (20%~80% Humidity)
Certifications	FCC/CE

1.4 Dimensions

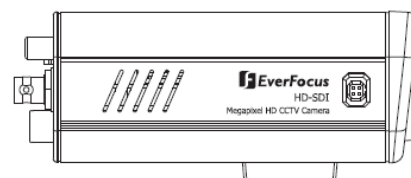
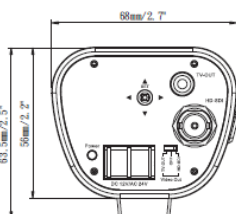
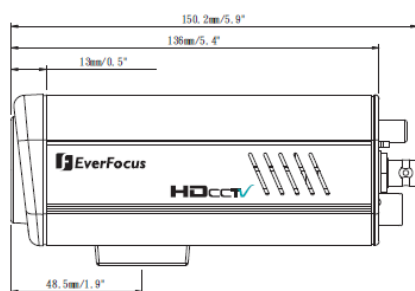

(Unit: mm/inch)

2. NAMES AND FUNCTIONS OF PARTS

2.1 Front panel

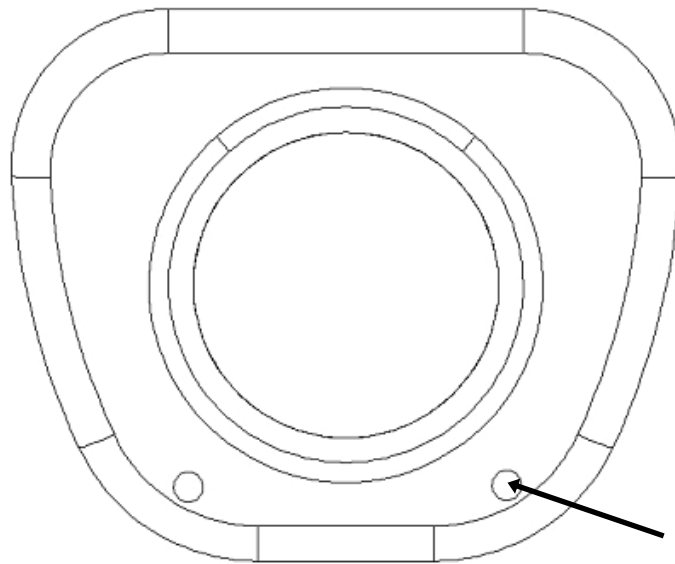

Light Sensor

TAKE CARE NOT TO OBSTRUCUT THIS OPENING
WITH THE BODY OF THE LENS!

The light sensor is for *optional* control of D/N switching levels in some applications. See section 5.6 for details.

2.2 Top/Bottom Mounting

Using the two phillips head screws provided, the mounting bracket may be mounted to the top of the camera body for suspending the camera; or, the brackets may be mounted to the bottom of the camera body to support the camera.

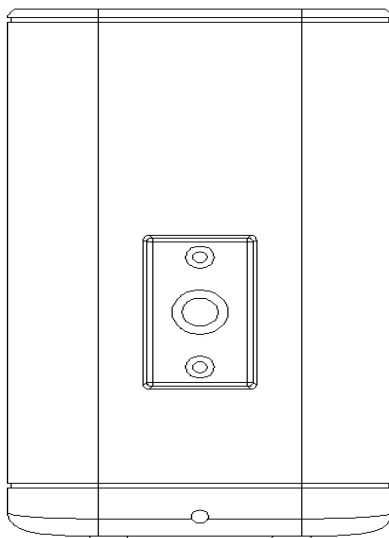

Top Bracket

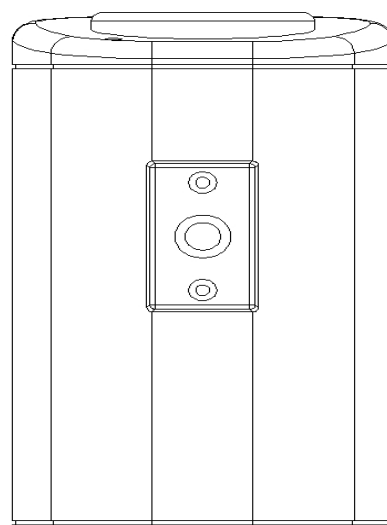

Bottom Bracket

2.3 Back panel and connections

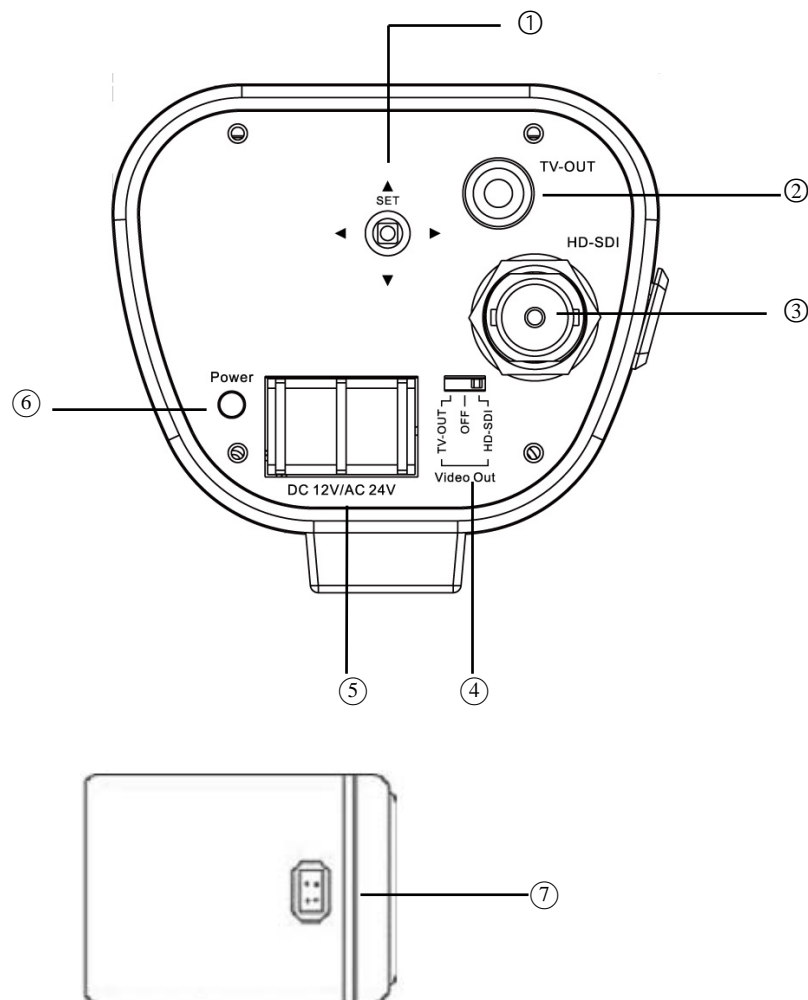

① **OSD Menu joystick:** Use the joystick to move the cursor Upwards/Downwards. This is used to select the item to be set. Tilt the stick to the right or left. This is used to select or adjust the parameters of the selected item. Press in on the stick to enter the setup menu.

② **TV-Out**

Connect to the TV-input of the Monitor by using a RCA connector.

③ **HD-SDI Output:** High-definition serial digital interface (BNC connector type). Connect to a video device through a 75 Ohm type coaxial cable to the BNC female connector at the rear of the camera.

④ **Video Out:** a switch to select which video output is used for connection.

⑤ **Power Input Terminal:** Connect 12VDC/24VAC power.

⑥ **Power LED:** The power LED lights up when power is ON.

⑦ **DC Auto Iris Lens Connector:** This connector is used to connect with the DC type auto iris lens using a standard 4 pin male connector

	Pin 1	Pin 2	Pin 3	Pin 4
Direct Drive	Cnt-	Cnt+	Drv+	Drv-



3. INSTALLATION

1. Unscrew/remove the cover cap from the lens mount.
2. If C mount lens is used, please add the C adaptor mount ring (the 5mm thick ring in the accessory pack) between the lens and the mount. **Please note:** Failure to use a spacer ring when attaching a C mount lens can damage the camera!
3. Mount the lens by turning it clockwise into the lens mount.
4. If you use an Auto Iris lens, connect the lens cable to the auto iris lens connector on the side of the camera.
5. After mounting and connecting the camera, when making final focus adjustments, remove the protective sheets from both sides of the ND filter provided; place the ND filter in front of the lens to force the lens iris to open; then adjust the lens focus until the best image is obtained.
6. Lock the lens focus by turning any clamping screws provided on the lens, then remove the ND filter.

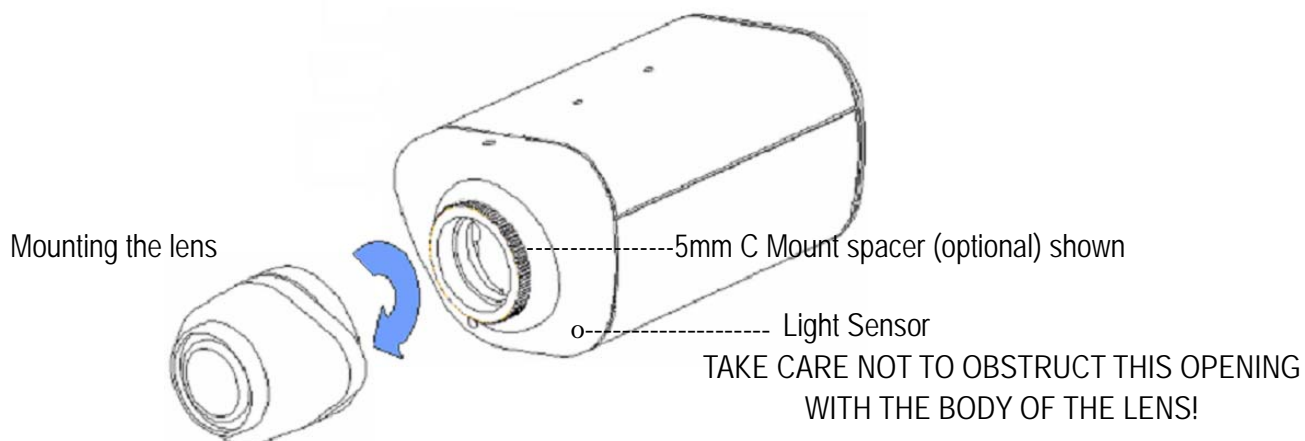

4. OSD Menu & Configuration

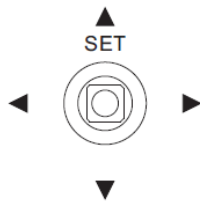

Access the user setup menu screen:

- I. **Press inward on the end of the joystick**
The menu screen will appear on the monitor.
- II. **Navigating with the joystick**
Angle the joystick ▲ or ▼ to move the cursor up or down. Angle the joystick ◀ or ▶ to adjust the mode or value of a setting.
- III. **Switching to sub-menu screens**
When an item with sub-menu is selected, press inward on the end of the joystick to switch to the sub-menu for further settings.
- IV. **Return to previous page**
Press the SET button to return to previous page if the choice displayed is Return.

Menu Tree

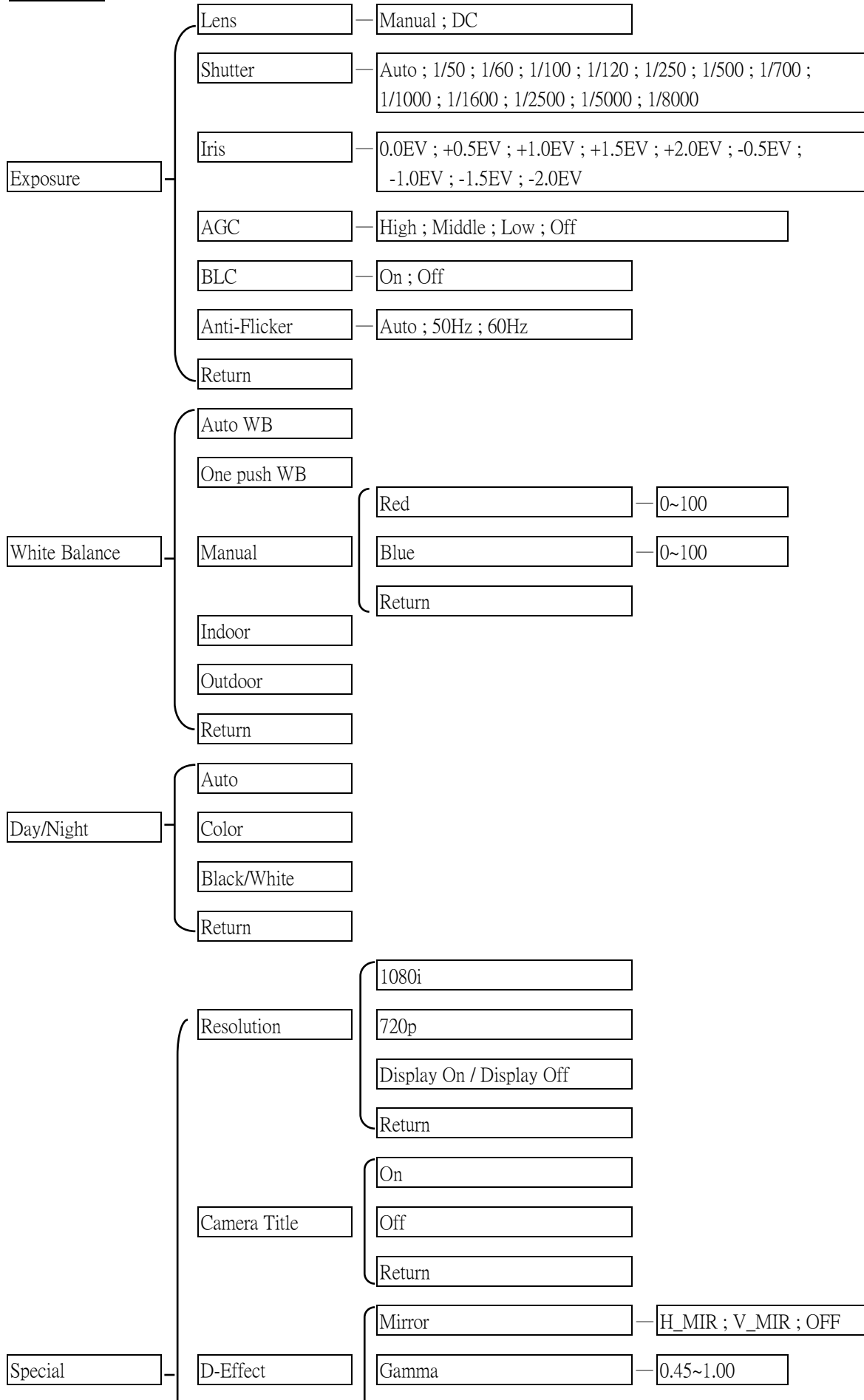

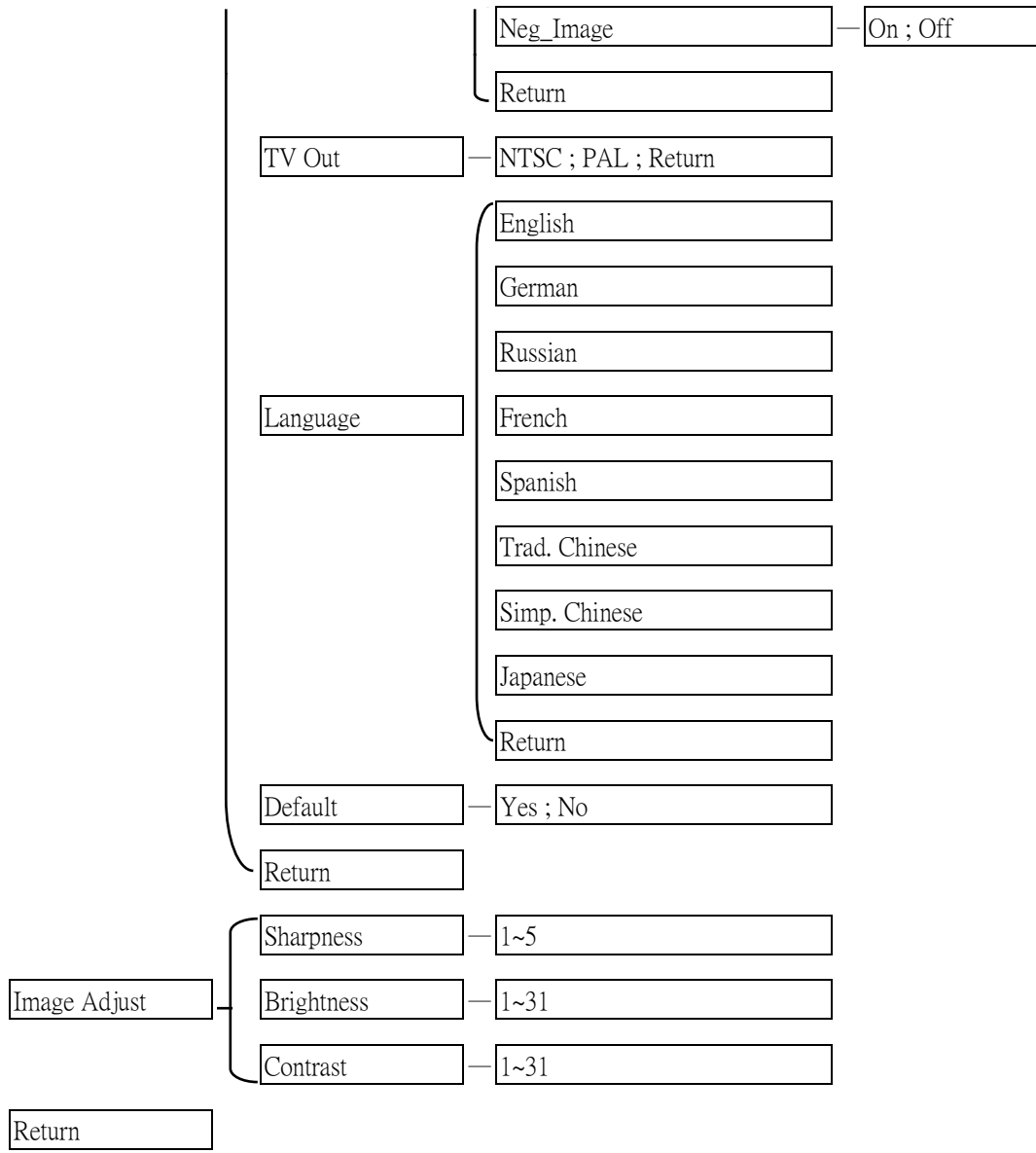

Press Set button to enter SETUP Menu. In SETUP menu, use the joystick to make settings. User can do camera settings including Exposure, White balance, Day/Night, Special and Image adjust. Please select the item by moving the joystick UP or DOWN then press SET to enter the settings. Move the joystick to the last option which is "Return" to return to live view.

4.1 Exposure

In this section, user can do camera settings including Lens, Shutter, Iris, AGC, BLC and Anti-flicker. Please select the item by moving the joystick UP or DOWN. Select "Return" to return to the previous menu.

4.1.1 Lens

Select the type of the lens used (Manual/DC type) by moving the joystick LEFT or RIGHT.

NOTE:

The brightness of the screen can be adjusted in DC mode in Lens Level. The level can be adjusted from 1 to 31.

4.1.2 Shutter

Select the shutter mode by moving the joystick LEFT or RIGHT.

Select from Auto, 1/50, 1/60, 1/100, 1/120, 1/250, 1/500, 1/700, 1/1000, 1/1600, 1/2500, 1/5000 and 1/8000.

NOTE:

When selecting a DC lens, the shutter speed is fixed as 1/60 for NTSC and 1/50 for PAL.

4.1.3 Iris

Select the iris mode by moving the joystick LEFT or RIGHT.

The level can be adjusted from 0.0EV, +0.5EV, +1.0EV, +1.5EV, +2.0EV, -0.5EV, -1.0EV, -1.5EV and -2.0EV.

4.1.4 AGC (Auto Gain Control – basic low light signal amplification)

Select the level you would like to choose by moving the joystick LEFT or RIGHT. The more the level of gain increases, the brighter the screen, but the level of noise increases as well. Please select from High, Middle, Low and Off.

4.1.5 BLC

Select "On" or "Off" by moving the joystick LEFT or RIGHT. Video gain can be adjusted automatically to correct the exposure of subjects that are in front of a bright light source.

4.1.6 Anti-Flicker

Selections are Auto, 50Hz and 60Hz. Camera will auto adjust the shutter to reduce the flicker caused by fluorescent light when manual lens is used.

4.2 White Balance Control

The screen color can be adjusted by using the White Balance function.

Please select one of the 5 modes below by moving the joystick UP or DOWN then press "Set" button to save the setting:

AWB

This mode can be used within the color temperature range from 2,500°K to 10,000°K.

One Push WB

Enable one push trigger for white balance mode. This holds the white balance at a specific color temperature until the next command trigger is given.

Manual

The manual adjustment mode enables a more precise adjustment. Set the suitable color temperature, and increase or decrease the red and blue color values at the same time while checking the color changes of the objects in view.

Return: Select "Return" to saves all settings in this menu and returns to the previous menu.

Indoor

Select this option when the color temperature is 4,000°K.

Outdoor

Select this option when the color temperature is 5,000~6,500°K.

Select "Return" to return to the previous menu.

4.3 Day/Night

These settings control the operation of the camera when the illumination level changes. Choices are Color at all times; B/W at all times; or color when illumination is bright, switching to B/W in low light.

Please select one of the 3 modes below by moving the joystick UP or DOWN then press "Set" button to save the setting:

- AUTO: The picture switches to color in a normal (bright) environment and switches to B/W when the ambient illumination is low. The switching point is determined by the AGC level.
- COLOR: The picture is always displayed in color, even at low light levels.
- B/W: The picture is always displayed in B/W.

Select "Return" to return to the previous menu.

NOTE:

AGC selection must be set as middle or high in order to employ the auto switching function.

4.4 Special

In this section, user can do special settings including Resolution, Camera Title, D-Effect, TV-Out, Language and Default. Please select the item by moving the joystick UP or DOWN then press SET to enter the settings. Select "Return" to return to the previous menu.

4.4.1 Resolution

1. Select camera resolution from 1920x1080i and 1280x720p by moving the joystick UP or DOWN then press "Set" button to save the setting
2. Display On: Press "Set" to switch between On/Off, whether to show current resolution.

Select "Return" to return to the previous menu.

4.4.2 Camera Title

Select "On" by moving the joystick UP or DOWN then press "Set" to enter the setting. Input a camera title by moving the joystick UP and Down, cursor will navigate among characters and numbers. The available letters are A-Z and 0-9. Press "Set" key to confirm. Move the joystick Left and Right to move the cursor among the same level.

Select "Off" by moving the joystick UP or DOWN then press "Set" to disable the camera title display.

Select "Return" to return to the previous menu.

4.4.3 D-Effect

In this section, user can do camera settings including Mirror, Gamma and Neg_Image. Please select the item by moving the joystick UP or DOWN. Select "Return" to return to the previous menu.

4.4.3.1 Mirror

Select one of the 3 modes below by moving the joystick LEFT or RIGHT.

-Off: Disable the effects.

-H-MIR: Sets a horizontal image inversion.

-V-MIR: Set a vertical image inversion.

4.4.3.2 Gamma

Select the Gamma level by moving the joystick LEFT or RIGHT.

The level can be adjusted from 0.45 up to 1.0.

4.4.3.3 NEG_IMAGE

Select Neg_Image On or Off by moving the joystick LEFT or RIGHT. Allows user to create a negative of the original image. A negative image is a tonal inversion of a positive image, in which light areas appear dark and vice versa. A negative color image is additionally color reversed, with red areas appearing cyan, greens appearing magenta and blues appearing yellow.

4.4.4 TV standard

Select video format of TV standard by moving the joystick UP or DOWN then press "Set" button to save the setting. Selectable from NTSC and PAL format.

Select "Return" to return to the previous menu.

4.4.5 Language

Select OSD language. EQH5200 camera supports multiple languages including English, German, Russian, French, Spanish, Traditional Chinese, Simplified Chinese and Japanese. Move the joystick UP or DOWN to select a language then press "Set" button to save the setting.

Select "Return" to return to the previous menu.

4.4.6 Default

Select "Yes" to load system settings to default factory values. Or select "No" to disregard this option.

4.5 Image Adjust

In this section, user can adjust Sharpness, Brightness and Contrast of the image. Please select the item by moving the joystick UP or DOWN. Select "Return" to return to the previous menu.

4.5.1 Sharpness

Select the sharpness level by moving the joystick LEFT or RIGHT. The contour of the video image becomes cleaner and more easily distinguished as the level of Sharpness increases. If the level is set too high, it may affect the video image and cause noise. The available range of level is 1-5.

4.5.2 Brightness

Select the brightness level by moving the joystick LEFT or RIGHT. To increase or decrease object brightness of images. It is adjustable from 1-31.

4.5.3 Contrast

Select the contrast level by moving the joystick LEFT or RIGHT. To increase or decrease object contrast of images. It is adjustable from 1-31.

EverFocus Electronics Corp.

Headquarter Office

12F, No.79 Sec.1 Shin-Tai Wu Road,
Hsi-Chi, Taipei, Taiwan
Tel: +886-2-26982334
Fax: +886-2-26982380

Beijing office

Room 609, Technology Trade Building,
Shangdi Information Industry Base,
Haidian District, Beijing China
Tel: +86-10-62971096
Fax: +86-10-62971423

European Office

Albert-Einstein-Strasse 1,
D-46446 Emmerich, Germany
Tel: +49-2822-9394-0
Fax: +49-2822-939495

Japan Office

5F Kinshicho City Building, 2-13-4 Koto-bashi,
Sumida-Ku, Tokyo, 130-0022, Japan
Tel: +81-3-5625-8188
Fax: +81-3-5625-8189

USA California Office

1801 Highland Ave. Unit A
Duarte, CA 91010, U.S.A
Tel: +1-626-844-8888
Fax: +1-626-844-8838

USA New York Office

415 Oser Ave Unit S
Hauppauge, NY 11788
Sales: +1-631-436-5070
Fax: +1-631-436-5027

India Office

Suite 803, 8th Floor,
Housefin Bhavan,
C-21 Bandra Kurla Complex,
Bandra (East), Mumbai 400 051
Tel: +91 22 6128-8700



Your EverFocus product is designed and manufactured with high quality materials and components which can be recycled and reused. This symbol means that electrical and electronic equipment, at their end-of-life, should be disposed of separately from your household waste. Please, dispose of this equipment at your local community waste collection/recycling centre. In the European Union there are separate collection systems for used electrical and electronic product. Please, help us to conserve the environment we live in!

Ihr EverFocus Produkt wurde entwickelt und hergestellt mit qualitativ hochwertigen Materialien und Komponenten, die recycelt und wieder verwendet werden können. Dieses Symbol bedeutet, dass elektrische und elektronische Geräte am Ende ihrer Nutzungsdauer vom Hausmüll getrennt entsorgt werden sollen. Bitte entsorgen Sie dieses Gerät bei Ihrer örtlichen kommunalen Sammelstelle oder im Recycling Centre. Helfen Sie uns bitte, die Umwelt zu erhalten, in der wir leben!



P/N: 4605XQ5200001AR

Free Manuals Download Website

<http://myh66.com>

<http://usermanuals.us>

<http://www.somanuals.com>

<http://www.4manuals.cc>

<http://www.manual-lib.com>

<http://www.404manual.com>

<http://www.luxmanual.com>

<http://aubethermostatmanual.com>

Golf course search by state

<http://golfingnear.com>

Email search by domain

<http://emailbydomain.com>

Auto manuals search

<http://auto.somanuals.com>

TV manuals search

<http://tv.somanuals.com>