

# FX40HR MOTORIZED TREADMILL

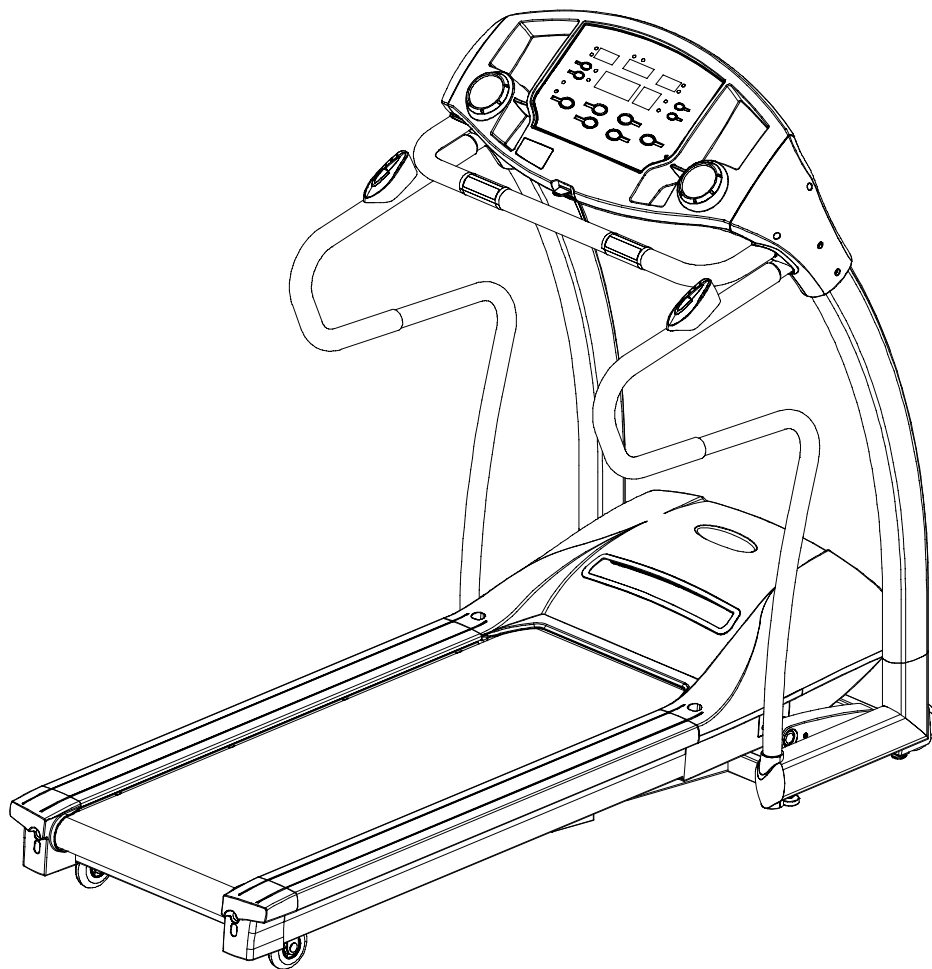

USER WEIGHT LIMITATION: **350bs (159 kgs)**

SERIAL NUMBER (found on frame):



## PRECAUTIONS

### For future service or related questions:

Please staple your receipt and/or write in the name and phone number of the retail store where you purchased your treadmill.

Name: \_\_\_\_\_ Phone Number: \_\_\_\_\_ Receipt: \_\_\_\_\_

### Precautions:

**WARNING:** To reduce the risk of burns, fire, electric shock, or injury to persons, read the following important precautions and information before operating the treadmill. It is the responsibility of the owner to ensure that all users of this treadmill are adequately informed of all warnings and precautions.

- Use the treadmill only as described in this manual.
- Place on a level surface, with 6 feet (2 m) of clearance behind it. Do not place the treadmill on any surface that blocks air openings. To protect the floor or carpet from damage, place a mat under the treadmill.
- When choosing a location for the treadmill be sure that the location and position permit access to a plug.
- Keep the treadmill indoors, away from moisture and dust. Do not put the treadmill in a garage or covered patio, or near water.
- Do not operate the treadmill where aerosol products are used or where oxygen is being administered.
- Keep children under the age of 12 and pets away from the treadmill at all times.
- The treadmill should not be used by persons weighing more than **350lbs (159 kgs. )**
- Never allow more than one person on the treadmill at a time. Wear appropriate exercise clothing when using the treadmill. Do not wear loose clothing that could become caught in the treadmill. Athletic support clothes are recommended for both men and women. Always wear athletic shoes. Never use the treadmill with bare feet, wearing only stockings, or in sandals.
- When connecting the power cord, plug the power cord into a grounded circuit. No other appliance should be on the same circuit.
- Always straddle the belt and allow it to start moving before stepping onto the belt.
- Always examine your treadmill before using to ensure all parts are in working order.
- Allow the belt to fully stop before dismounting.
- Never insert any object or body parts into any opening.
- Follow the safety information in regards to plugging in your treadmill.
- Keep the power cord away from the incline wheels and do not run the power cord underneath your treadmill. Do not operate the treadmill with a damaged or frayed power cord.
- Always unplug the treadmill before cleaning and/or servicing. Service to your treadmill should only be performed by an authorized service representative, unless authorized and/or instructed by the manufacturer. Failure to follow these instructions will void the treadmill warranty.
- Never leave the treadmill unattended while it is running.
- This equipment is Class B (Home Use Only).

## POWER REQUIREMENTS

### Power Requirements:

IMPROPER CONNECTION OF THE EQUIPMENT GROUNDING CONNECTOR CAN RESULT IN THE RISK OF AN ELECTRIC SHOCK. CHECK WITH A QUALIFIED ELECTRICIAN OR SERVICE MAN IF YOU ARE IN DOUBT AS TO WHETHER THE PRODUCT IS PROPERLY GROUNDING. DO NOT MODIFY THE PLUG PROVIDED WITH THE PRODUCT, IF IT WILL NOT FIT THE OUTLET; HAVE A PROPER OUTLET INSTALLED BY A QUALIFIED ELECTRICIAN.

This treadmill can be seriously damaged by sudden voltage changes in your home's electrical power. Voltage spikes, surges and noise interference can result from weather conditions or from other appliances being turned on or off. To reduce the possibility of treadmill damage, always use a surge protector (not included) with your treadmill.

Surge protectors can be purchased at most hardware stores. The manufacturer recommends a single outlet surge protector with a UL 1449 rating as a Transient Voltage Surge Suppressor (TVSS) with a UL suppressed voltage rating of 400V or less and an electrical rating 110VAC, 15 amps.

This treadmill must be grounded to reduce the risk of electrical shock. Grounding provides a path of least resistance for electric current, should the treadmill malfunction. This treadmill is equipped with an electrical cord that has an equipment-grounding conductor and a grounding plug. Always plug the power cord into a surge protector, and plug the surge protector into an appropriate outlet that is properly installed and grounded in accordance with all local codes and ordinances.

This product is for use on a nominal 110-volt circuit, and has a grounding plug that looks like the plug illustrated in the drawing below.

GFCI outlets and GFCI Circuit Breakers are NOT recommended for use on this product. GFCI outlets and GFCI Circuit Breakers may cause this equipment to improperly function.

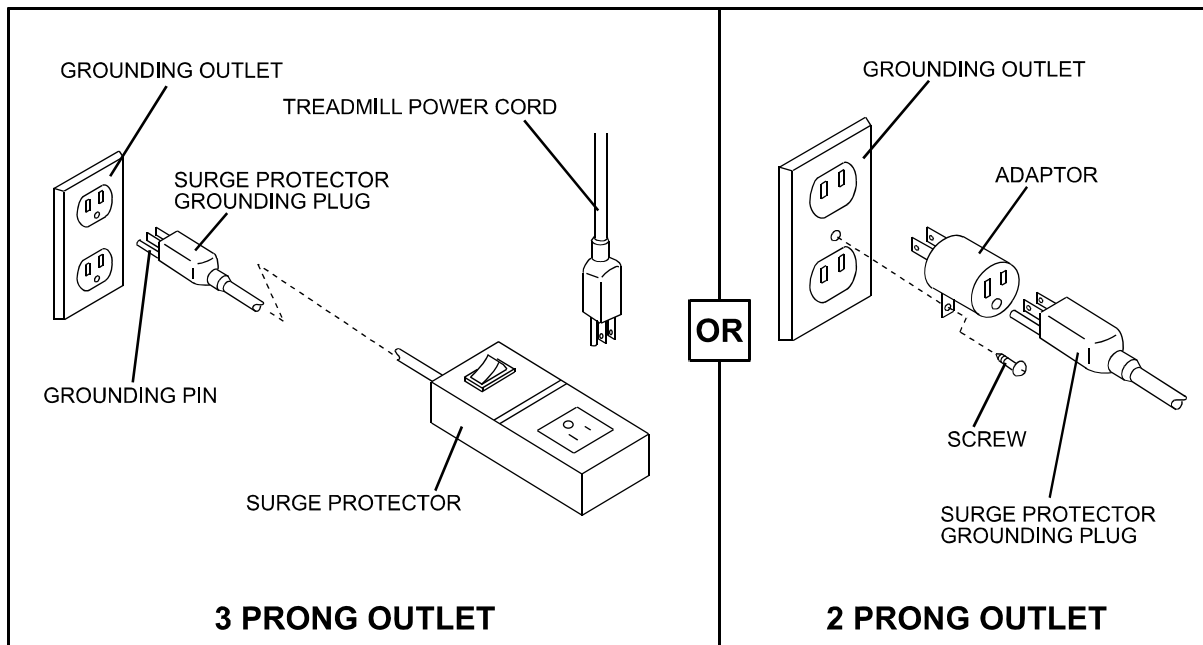

## Before You Begin

### ▪ **Open the boxes:**

Open the boxes of your new equipment. Inventory all parts included in the boxes, and compare them to the Supplied Components and Supplied Hardware lists on pages 5-6 for a full count of the parts included. If you are missing any parts or have any questions contact us directly at 888-800-1167

\*Assembly instructions begin on page 10.

### ▪ **Gather your tools:**

Before you begin, make sure that you have gathered all the necessary tools you may require to assemble the unit properly. Having all of the necessary equipment at hand will save time and make the assembly quick and hassle-free.

### ▪ **Clear your work area:**

Make sure that you have cleared away a large enough space to properly assemble the unit. Make sure the space is free from anything that may cause injury during assembly. After the unit is fully assembled, make sure there is a comfortable amount of free area around the unit for unobstructed operation.

### ▪ **Invite a friend:**

Some of the assembly steps may require heavy lifting. It is recommended that you obtain the assistance of another person when assembling this product.

### ▪ **User Weight Limitation:**

Please note that there is a weight limitation for this product. If you weigh more than 275LB (Approx. 124 Kg) it is not recommended that you use this product. Serious injury may occur if the user's weight exceeds the limit shown here. This product is not intended to support users whose weight exceeds this limit.

### ▪ **Care and maintenance:**

The safety level can be maintained only if it is examined for damage and wear.

Replace any defective components immediately and stop all use of the equipment until repaired.

Always take care when mounting the equipment. Straddle the equipment by placing your feet on the straddle rails. Dismount from the equipment only after all parts have stopped.

Always check the wear and tear components like pulley, belts, etc....To prevent injury.

There is an emergency stop, in the form of a SAFETY KEY, to prevent injury; you can stop the treadmill immediately by actuating the emergency stop for emergency dismount

## Supplied Components

This list identifies the major components you will use to assemble this product. Component A, B, C and E are already partially assembled

No.	Description	Qty.
A	Computer	1
B	Front Handlebar Assembly	1
C	Handlebar	2
D	Upright Assembly	2
E	Main Frame Assembly	1
202	Handlebar Lower Cover	2
302	Upright Cover-LL	1
303	Upright Cover -LR	1
304	Upright Cover -RL	1
305	Upright Cover -RR	1

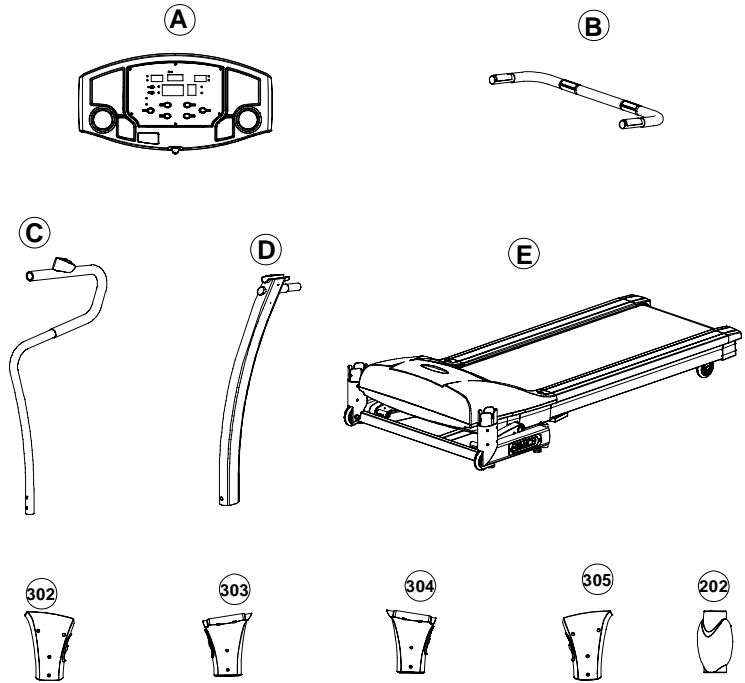

## Supplied Hardware

This list identifies the hardware you will use to assemble the product. To help distinguish between the various types of screws and bolts, use the scale below to measure them and compare them to the sizes listed.

No.	Description	Qty.
804	M8 x 15mm Bolt	2
805	M8 x 50mm Bolt	8
806	#8 x 19mm Screw	8
807	#8 x 19mm Screw	8
A	5mm Wrench	1
B	8mm Wrench	1
C	Wrench	1
D	5mm Allen Wrench	1

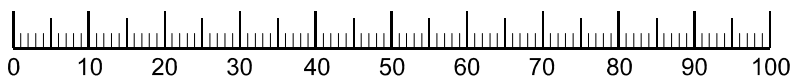
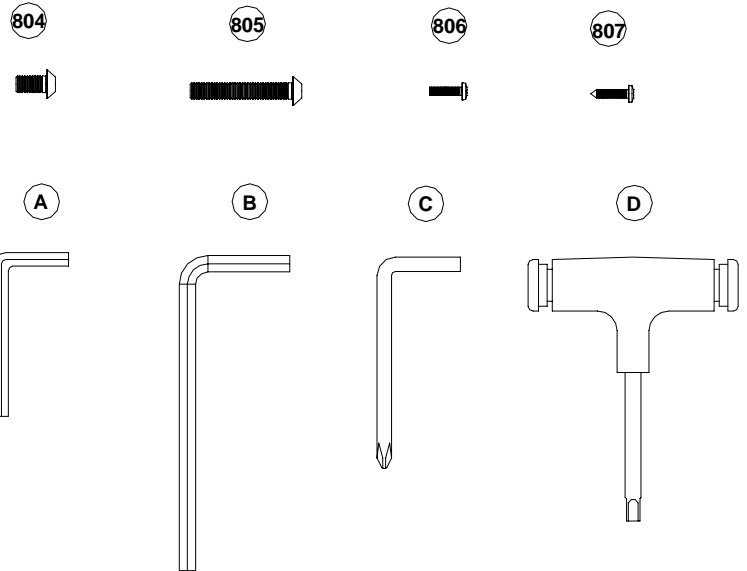

MILLIMETERS

## Complete Parts List

No.	Description	Qty.	Order Number
<b>FX40HR-100</b>	<b>Complete Computer Console</b>		
FX40HR-101	Overlay	1	FX40HR-101
FX40HR-102	Computer Insert	1	FX40HR-102
FX40HR-103	Console PC Board	1	FX40HR-103
FX40HR-104	Console Housing - Upper	1	FX40HR-104
FX40HR-105	Console Housing - Bottom	1	FX40HR-105
FX40HR-106	Safety key Base	1	FX40HR-106
FX40HR-107	Safety Key	1	FX40HR-107
FX40HR-108	Safety Key Wire - Upper	1	FX40HR-108
FX40HR-109	Computer Wire - Upper	1	FX40HR-109
FX40HR-110	Computer Ground Wire	1	FX40HR-110
FX40HR-111	Hand Pulse Wire - Upper	2	FX40HR-111
FX40HR-112	E - Prom	1	FX40HR-112
FX40HR-113	Motion Control Board	1	FX40HR-113
FX40HR-114	Motion Control Board Wire	1	FX40HR-114
FX40HR-115	Motion Control Sensor Wire	2	FX40HR-115
FX40HR-116	Water Bottle Holder	2	FX40HR-116
<b>FX40HR-200</b>	<b>Complete Handle Bar Components</b>		
FX40HR-201	Handle Bar Upright	2	FX40HR-201
FX40HR-202	Handle Bar Upright Rear End Cap	2	FX40HR-202
FX40HR-203	Handle Bar Upright Foam Grip	2	FX40HR-203
FX40HR-204	Front Handle Bar	1	FX40HR-204
FX40HR-205	Front Handle Bar Foam Grip-Short	1	FX40HR-205
FX40HR-206	Front Handle Bar Foam Grip-Long	2	FX40HR-206
FX40HR-207	Hand Pulse Set	2	FX40HR-207
FX40HR-208	Motion Control	2	FX40HR-208
FX40HR-209	Motion Control Base	2	FX40HR-209
<b>FX40HR-300</b>	<b>Complete Upright Components</b>		
FX40HR-301	Upright	2	FX40HR-301
FX40HR-302	Upright Cover –LL	1	FX40HR-302
FX40HR-303	Upright Cover –LR	1	FX40HR-303
FX40HR-304	Upright Cover –RL	1	FX40HR-304
FX40HR-305	Upright Cover –RR	1	FX40HR-305
FX40HR-306	Safety Key Wire – Middle	1	FX40HR-306

## PARTS LIST

No.	Description	Qty.	Order Number
FX40HR-307	Computer Wire – Upper	1	FX40HR-307
FX40HR-308	Motion Control Sensor Wire – Middle	2	FX40HR-308
<b>FX40HR-400</b>	<b>Complete Base Frame Components</b>		
FX40HR-401	Base Frame	1	FX40HR-401
FX40HR-402	Safety Key Wire – Lower	1	FX40HR-402
FX40HR-403	Computer Wire –Lower	1	FX40HR-403
FX40HR-404	Power Switch Plate Cover	1	FX40HR-404
FX40HR-405	Power Switch Plate	1	FX40HR-405
FX40HR-406	Power Breaker	1	FX40HR-406
FX40HR-407	Power Switch	1	FX40HR-407
FX40HR-408	Fold UP Support	1	FX40HR-408
FX40HR-409	Foot Locker	1	FX40HR-409
FX40HR-410	Foot Locker Spring	1	FX40HR-410
FX40HR-411	Shock	1	FX40HR-411
FX40HR-412	Fix Bolt Sets	2	FX40HR-412
FX40HR-413	Front Caster	2	FX40HR-413
FX40HR-414	Rubber Cushion	2	FX40HR-414
FX40HR-415	Level Adjuster	2	FX40HR-415
FX40HR-416	Base Frame End Cap	2	FX40HR-416
FX40HR-417	Cushion	2	FX40HR-417
FX40HR-418	Transportation Wheel Bracket	2	FX40HR-418
FX40HR-419	Transportation Wheel Bracket	1	FX40HR-419
FX40HR-420	Spring	1	FX40HR-420
FX40HR-421	Rear Transportation Wheel	1	FX40HR-421
FX40HR-422	Plastic Insert	1	FX40HR-422
FX40HR-423	Fold Up Support Wheel	1	FX40HR-423
FX40HR-424	Bushing	2	FX40HR-424
<b>FX40HR-500</b>	<b>Complete Motor Components</b>		
FX40HR-501	Motor Hood	1	FX40HR-501
FX40HR-502	Elevation Motor	1	FX40HR-502
FX40HR-503	Elevation Gear Sleeve	1	FX40HR-503
FX40HR-504	Driving Motor	1	FX40HR-504
FX40HR-505	Motor Holder	1	FX40HR-505



**PARTS LIST**

No.	Description	Qty.	Order Number
FX40HR-506	Driving Belt	1	FX40HR-506
FX40HR-507	Motor Control Board	1	FX40HR-507
FX40HR-508	Elevation Control Board	1	FX40HR-508
FX40HR-509	Elevation Support Tube	1	FX40HR-509
FX40HR-510	ELEVATION SUPPORT TUBE COVER – LEFT	1	FX40HR-510
FX40HR-511	MOTOR BOTTOM COVER	1	FX40HR-511
FX40HR-512	DECK FRAME SIDE COVER – LEFT	1	FX40HR-512
FX40HR-513	PLASTIC CLAMP – TOP	2	FX40HR-513
FX40HR-514	PLASTIC CLAMP – BOTTOM	2	FX40HR-514
FX40HR-515	ELEVATION SUPPORT	2	FX40HR-515
FX40HR-516	ELEVATION SUPPORT CAP	2	FX40HR-516
FX40HR-517	DECK RUBBER CUSHION	2	FX40HR-517
FX40HR-518	Rear Vent Cover	1	FX40HR-518
FX40HR-519	ELEVATION SUPPORT TUBE COVER – Right	1	FX40HR-519
FX40HR-520	DECK FRAME SIDE COVER – Right	1	FX40HR-520
<b>FX40HR-600</b>	<b>Complete Running Deck Components</b>		
FX40HR-601	RUNNING BELT	1	FX40HR-601
FX40HR-602	SIDE RAIL	2	FX40HR-602
FX40HR-603	SIDE RAIL END CAP – LEFT	1	FX40HR-603
FX40HR-604	SIDE RAIL END CAP – Right	1	FX40HR-604
FX40HR-605	RUNNING DECK	1	FX40HR-605
<b>FX40HR-700</b>	<b>Complete Deck Frame Components</b>		
FX40HR-701	DECK FRAME	1	FX40HR-701
FX40HR-702	Front Roller Shaft	1	FX40HR-702
FX40HR-703	Front Roller Tube	1	FX40HR-703
FX40HR-704	Roller Bearing 6202	4	FX40HR-704
FX40HR-705	Rear Roller Shaft	1	FX40HR-705
FX40HR-706	Rear Roller Tube	1	FX40HR-706
FX40HR-707	RUNNING DECK SUPPORT TUBE	1	FX40HR-707
FX40HR-708	DECK FRAME – REAR	1	FX40HR-708
FX40HR-413	Rear Caster	2	FX40HR-413
<b>FX40HR-800</b>	<b>Complete Hardware PACK</b>		
FX40HR-801	# 6 × 12mm Screws	12	FX40HR-801
FX40HR-802	# 4 × 6mm Screws	12	FX40HR-802

## PARTS LIST

No.	Description	Qty.	Order Number
FX40HR-803	# 8 × 12mm Screws	8	FX40HR-803
FX40HR-804	M8 x 15mm Bolt	2	FX40HR-804
FX40HR-805	M8 x 50mm Bolt	8	FX40HR-805
FX40HR-806	#8 x 19mm Screw	13	FX40HR-806
FX40HR-807	#8 x 19mm Screw	9	FX40HR-807
FX40HR-808	M5 × 10mm Screws	3	FX40HR-808
FX40HR-809	# 8 × 16 Screws	36	FX40HR-809
FX40HR-810	C Fixed	1	FX40HR-810
FX40HR-811	M10 × 30mm Bolts	1	FX40HR-811
FX40HR-812	Bearing	1	FX40HR-812
FX40HR-813	Washer	8	FX40HR-813
FX40HR-814	Nylon Nut	7	FX40HR-814
FX40HR-815	M8 x 35mm Axle	1	FX40HR-815
FX40HR-816	M14 × 90 Screws	2	FX40HR-816
FX40HR-817	Bearing	4	FX40HR-817
FX40HR-818	M10 × 35mm Screws	10	FX40HR-818
FX40HR-819	# 8 × 10mm Screws	7	FX40HR-819
FX40HR-820	# 8 × 50mm Screws	2	FX40HR-820
FX40HR-821	M10 × 63mm Bolts	1	FX40HR-821
FX40HR-822	Fixed Block	8	FX40HR-822
FX40HR-823	M8 × 120mm Bolts	1	FX40HR-823
FX40HR-824	Plate Washer	2	FX40HR-824
FX40HR-825	Spring	1	FX40HR-825
FX40HR-826	Nylon Nut	1	FX40HR-826
FX40HR-827	M8 × 20mm Screws	6	FX40HR-827
FX40HR-828	Spring Washer	10	FX40HR-828
FX40HR-829	Washer	2	FX40HR-829
FX40HR-830	M10 × 136mm Screws	1	FX40HR-830
FX40HR-831	M10 × 90mm Screws	1	FX40HR-831
FX40HR-832	M8 × 25mm Screws	8	FX40HR-832
FX40HR-833	Hexagon Nut	8	FX40HR-833
FX40HR-834	M6 × 70mm Bolts	3	FX40HR-834
FX40HR-835	Washer	3	FX40HR-835
FX40HR-836	M10 x 40mm Axle	1	FX40HR-836



PARTS DIAGRAM

MOST OF THE PARTS SHOWN HERE HAVE ALREADY BEEN PRE-ASSEMBLED.

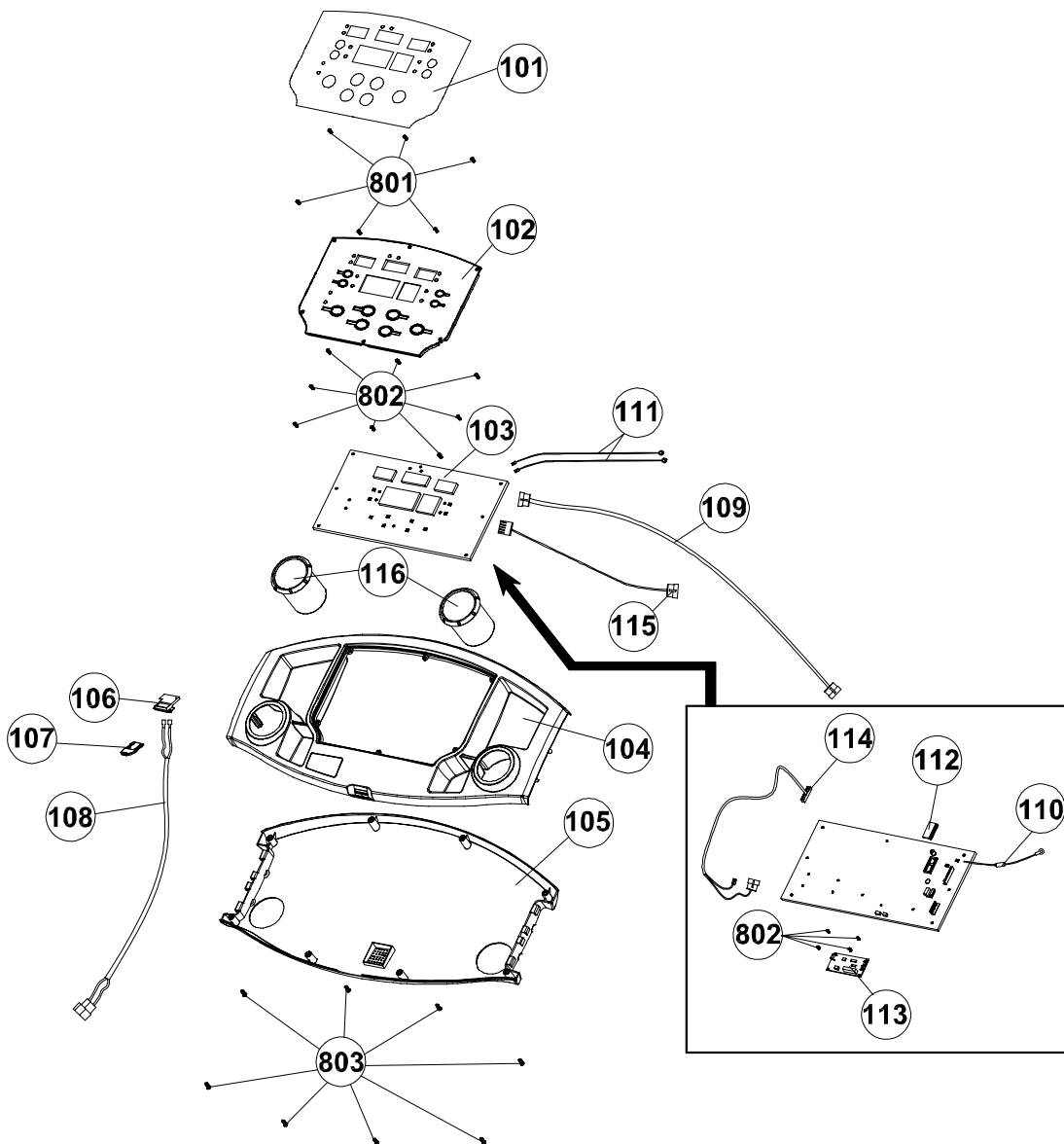
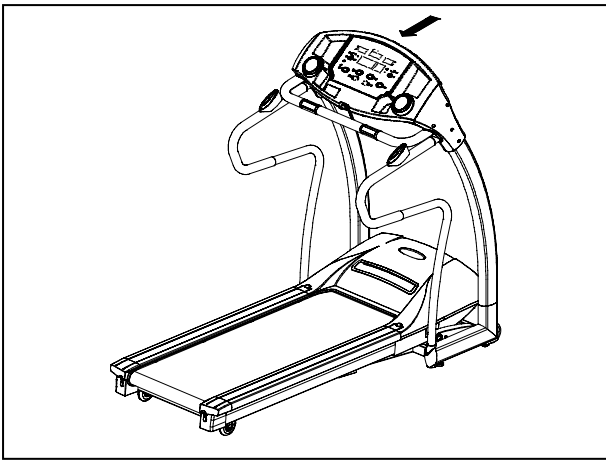

### PARTS DIAGRAM

MOST OF THE PARTS SHOWN HERE HAVE ALREADY BEEN PRE-ASSEMBLED.

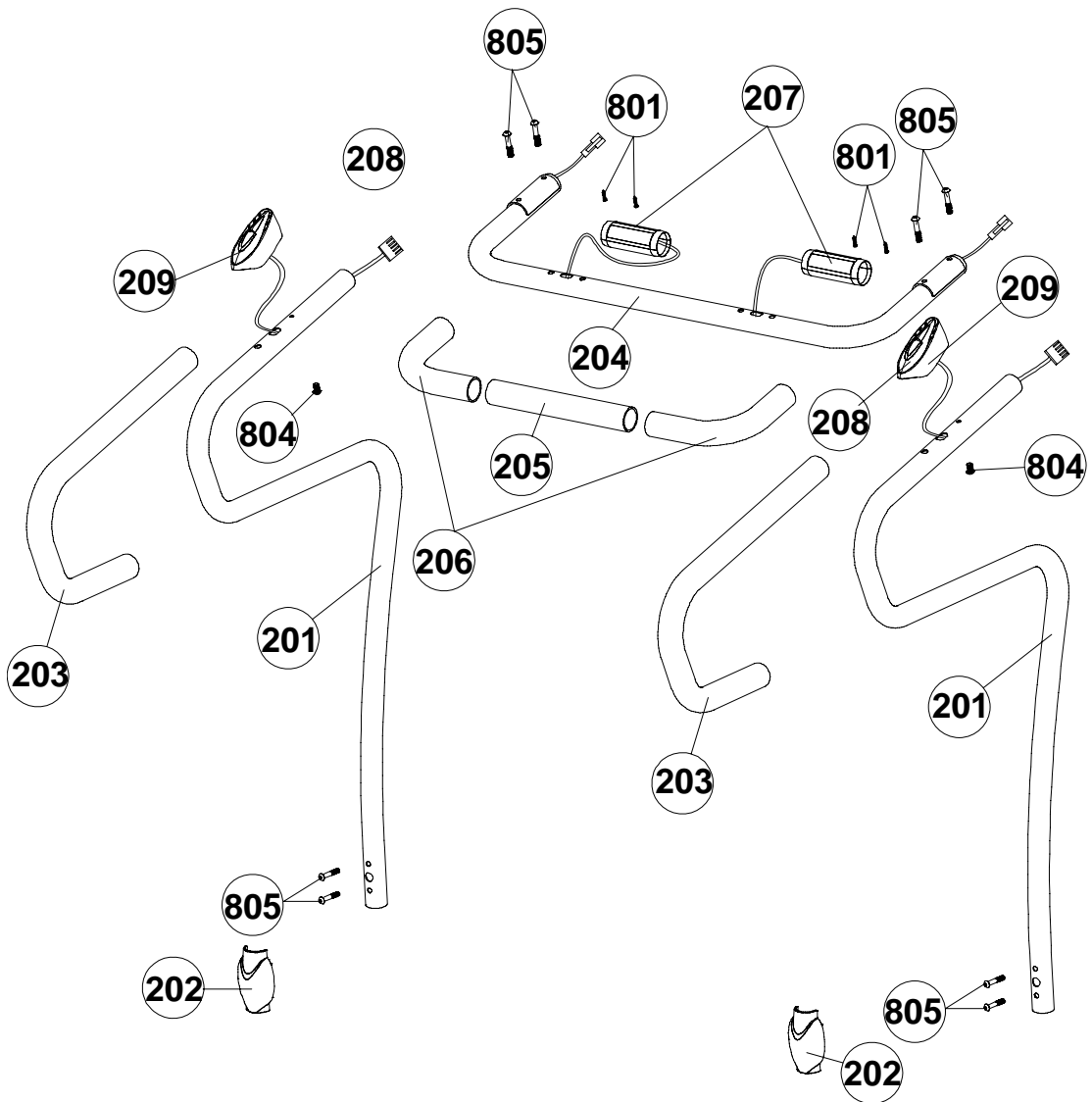
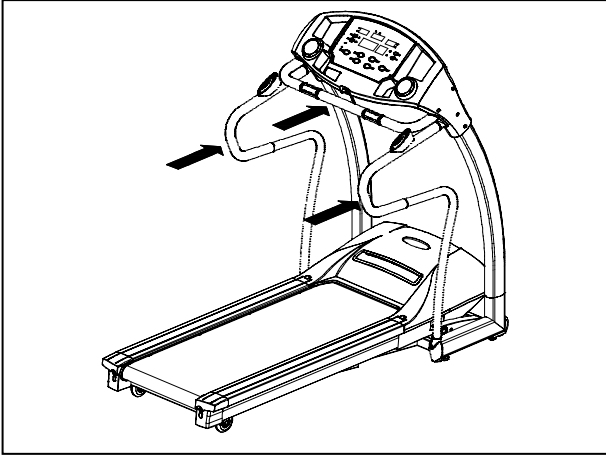

## PARTS DIAGRAM

MOST OF THE PARTS SHOWN HERE HAVE ALREADY BEEN PRE-ASSEMBLED.

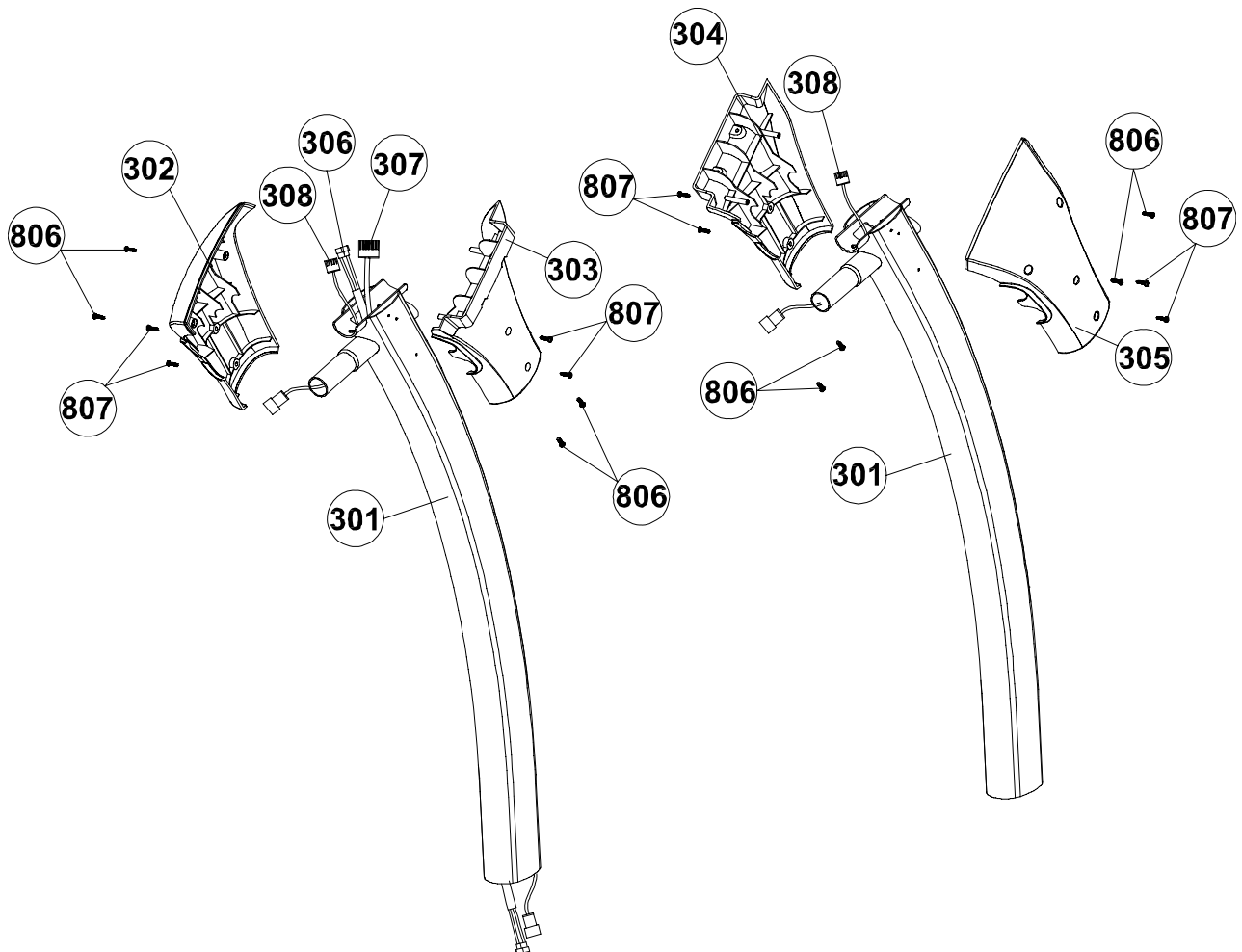
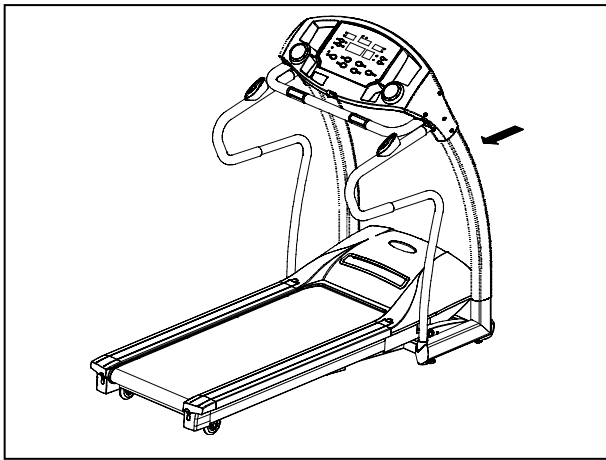

# PARTS DIAGRAM

MOST OF THE PARTS SHOWN HERE HAVE ALREADY BEEN PRE-ASSEMBLED.

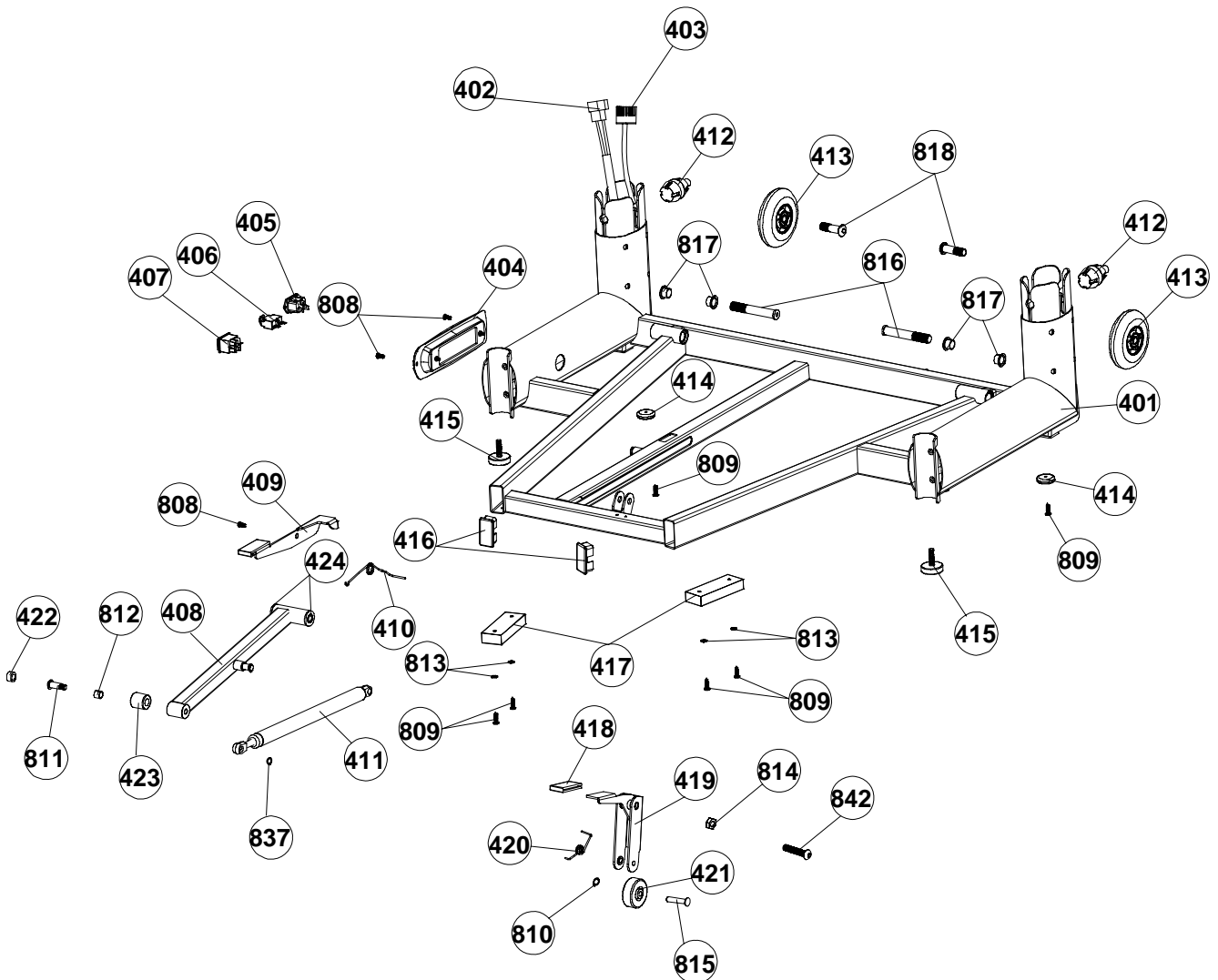
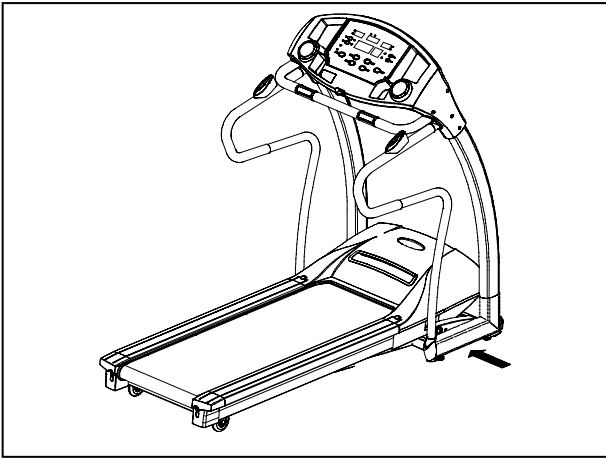

### PARTS DIAGRAM

MOST OF THE PARTS SHOWN HERE HAVE ALREADY BEEN PRE-ASSEMBLED.

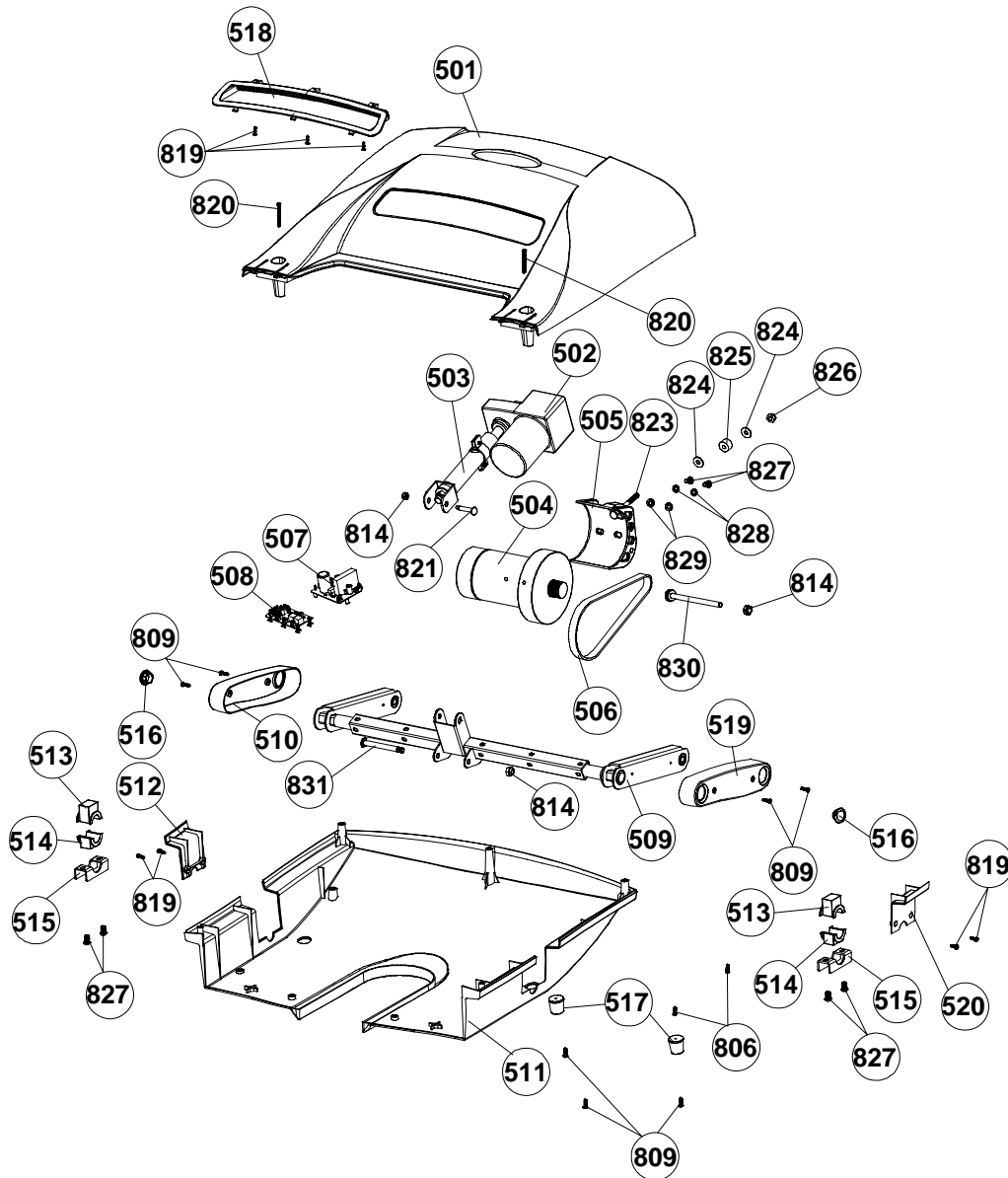
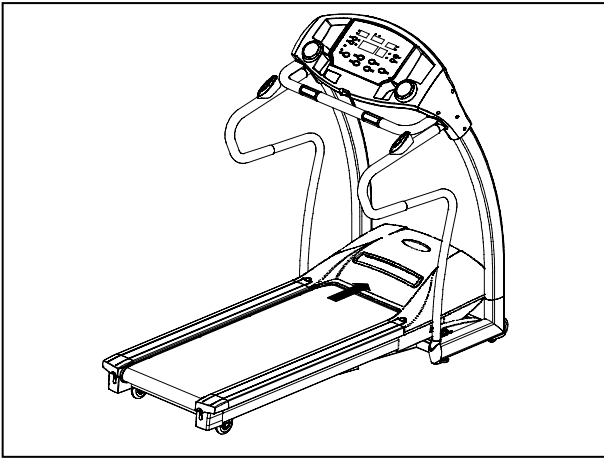



# PARTS DIAGRAM

MOST OF THE PARTS SHOWN HERE HAVE ALREADY BEEN PRE-ASSEMBLED.

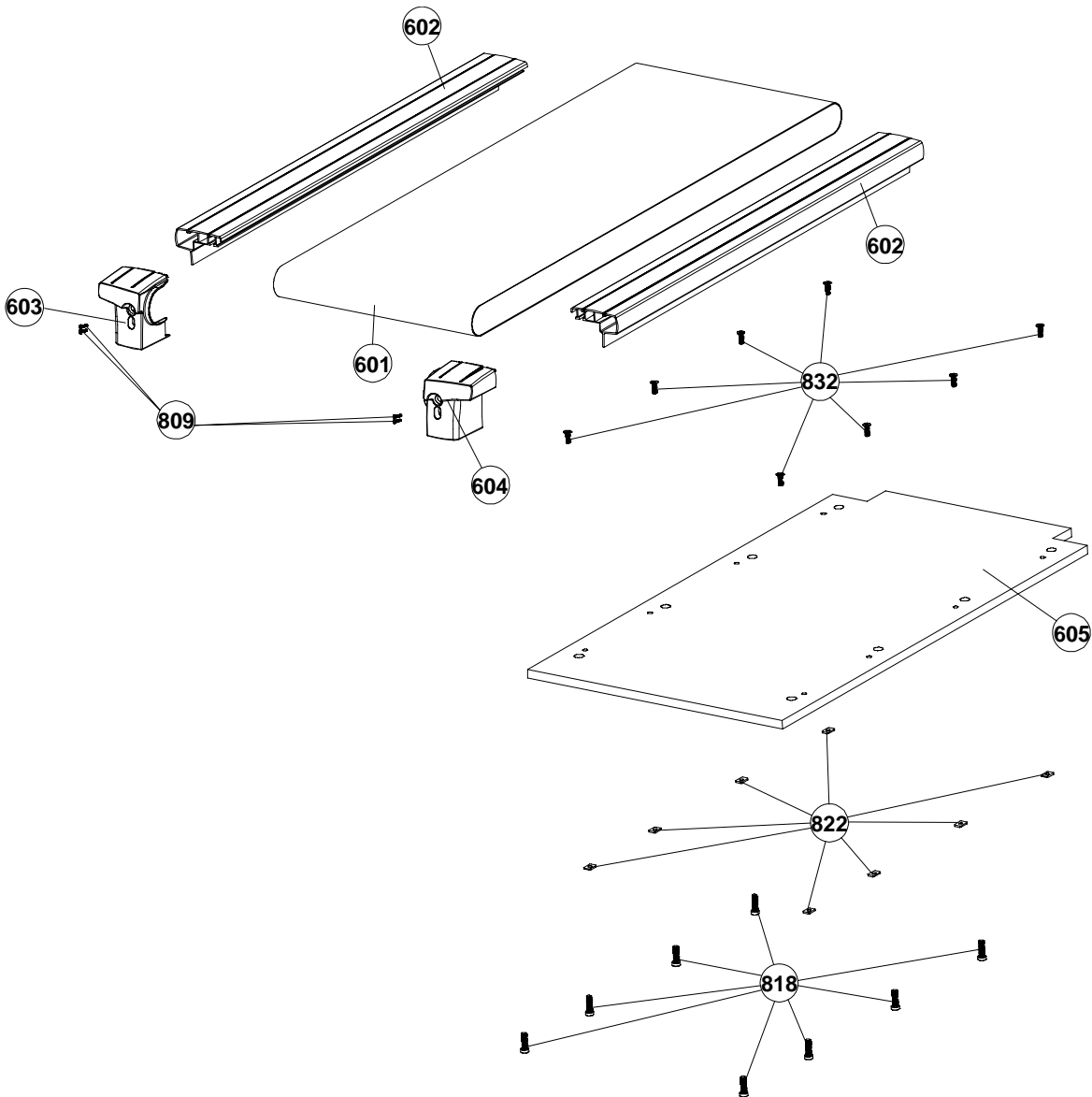
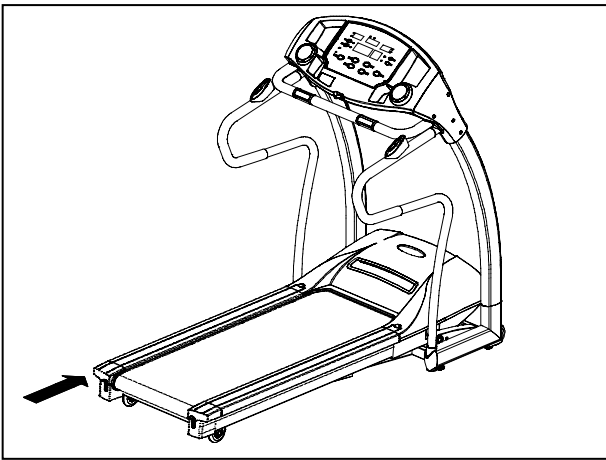

**PARTS DIAGRAM**

MOST OF THE PARTS SHOWN HERE HAVE ALREADY BEEN PRE-ASSEMBLED.

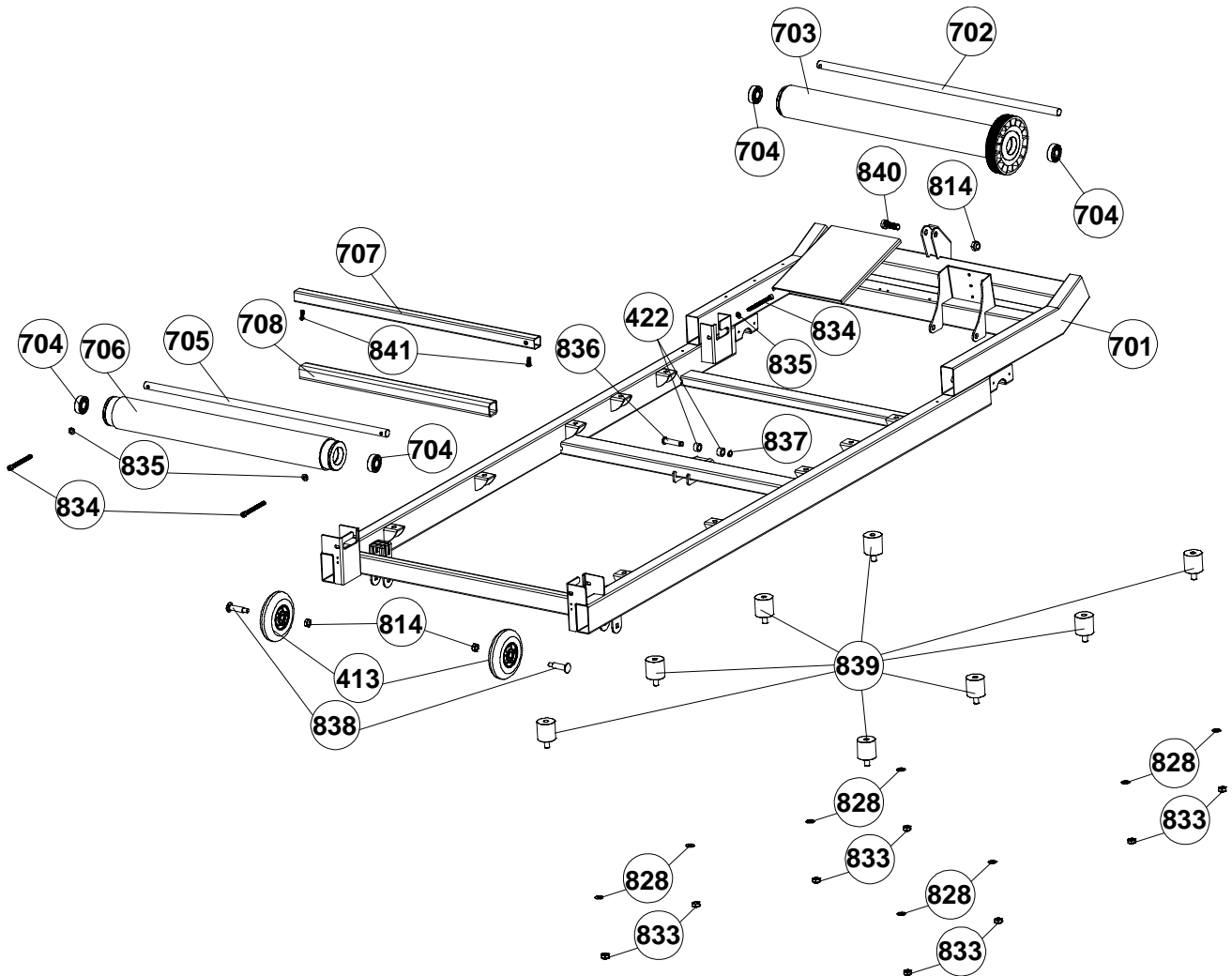
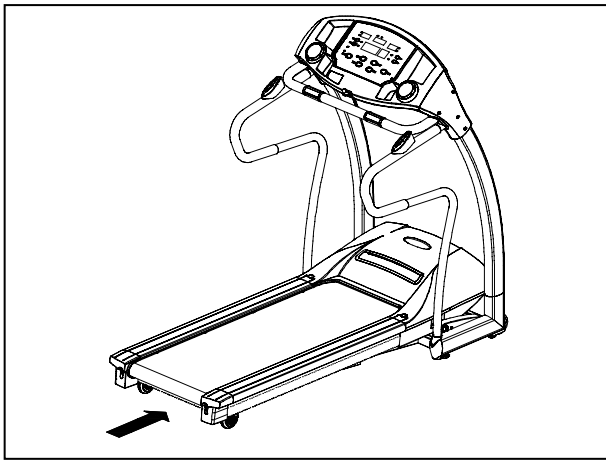

**ASSEMBLY****STEP 1: Unpacking and Inventory**

- A) Remove your treadmill from the carton and place it on the floor in an open area.
- B) Remove the treadmill and all the components and hardware from the box.
- C) Check the quantities of all components and hardware with the component and hardware lists on pages 5-6
- D) After verifying inventory if there are any missing parts please contact smooth fitness at 1-888-800-1167

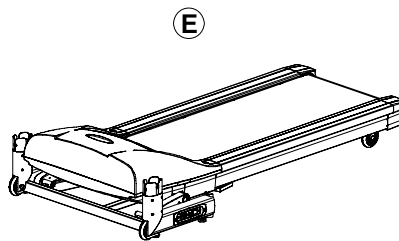
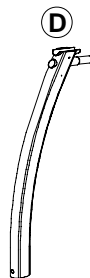
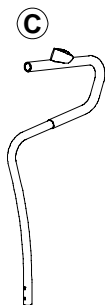
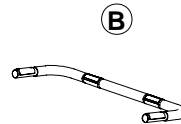
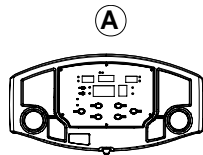

**ASSEMBLY****STEP 2: Assemble Upright Frame**

**NOTE:** Make sure all wires are recessed into the frame. **DO NOT** trap or pinch **DO NOT** tighten bolts until **STEP 9)**

- A) Connect the Lower and middle section wires as seen below (306 to 402)(307 to 403)
- B) Insert any extra cable length into the Left Upright (301).
- C) Insert the Left and Right Uprights (301) into the Base Frame (401).

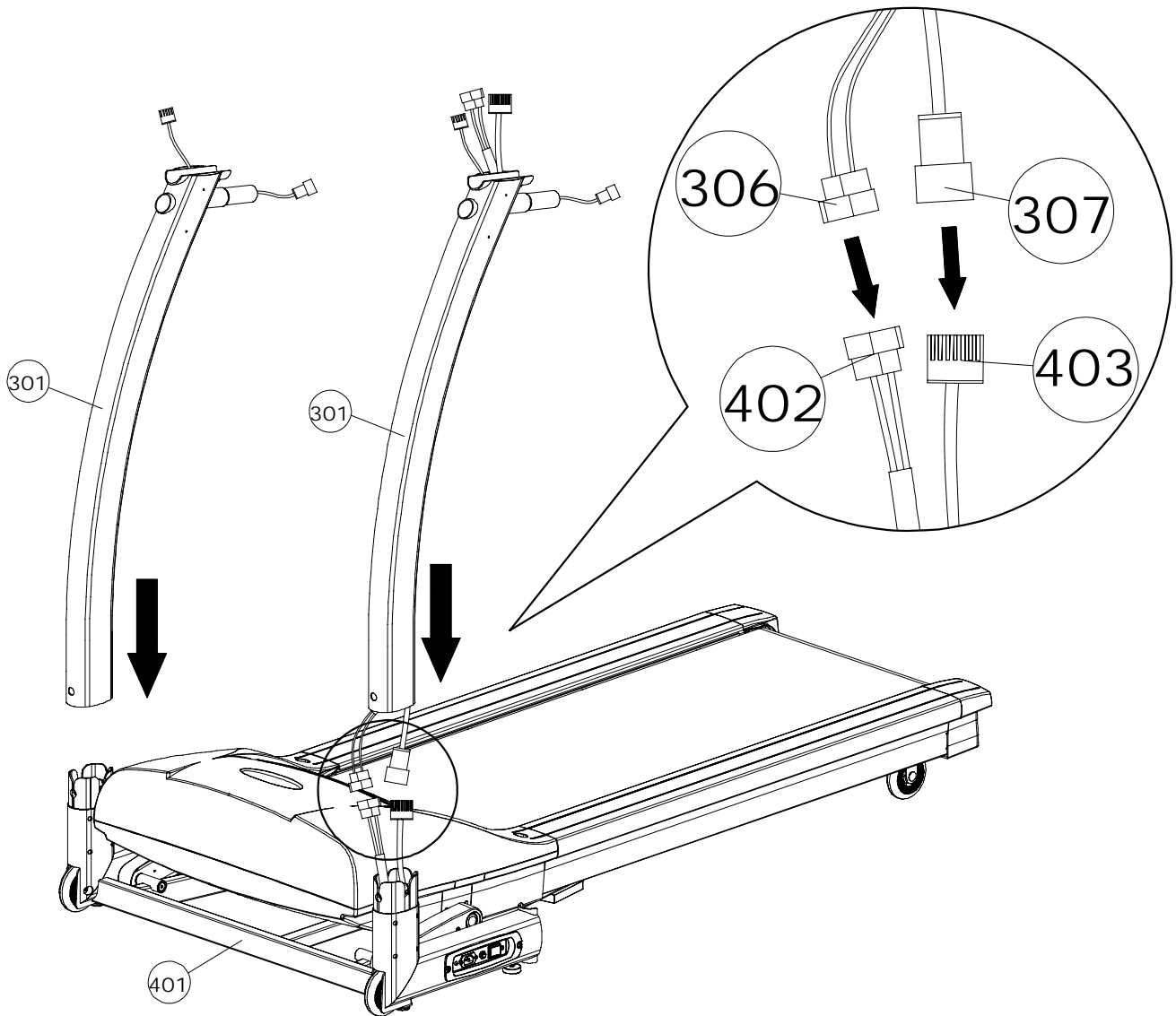

**ASSEMBLY****STEP 3: Assemble The Side Handlebars**

**NOTE:** Side rails are interchangeable for use on both right and left sides. Make sure all wires are recessed into the frame. DO NOT trap or pinch

- A) Connect the Left Motion Control lower wire to the middle wire. (208 to 308). As Shown in the diagram below.
- B) Insert the Left Handlebar (201) into the Upright Tube. Use one M8x15mm bolt (804) to secure the upper portion. Use two M8x50mm bolts to secure the lower portion to the base frame.
- C) Repeat the above process for the Right side.

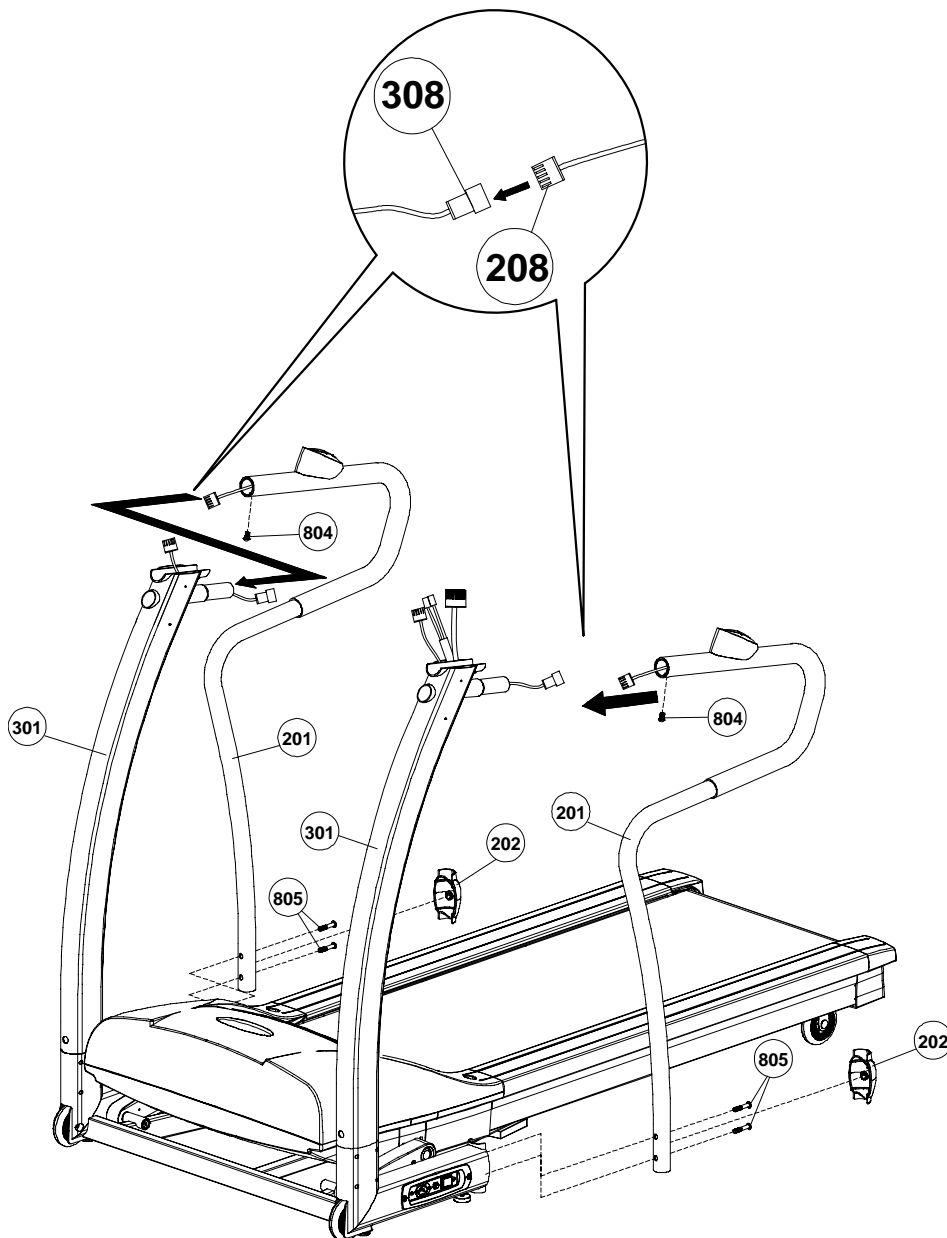
**804 X2****805 X4**

**ASSEMBLY****STEP 4: Assemble Front Handlebar**

- A) Place the front handlebar (204) on top of the left and right uprights (301)
- B) Now secure the front handle bar with 4 M8x50mm bolts (805).
- C) Tighten all handlebar hardware.

805

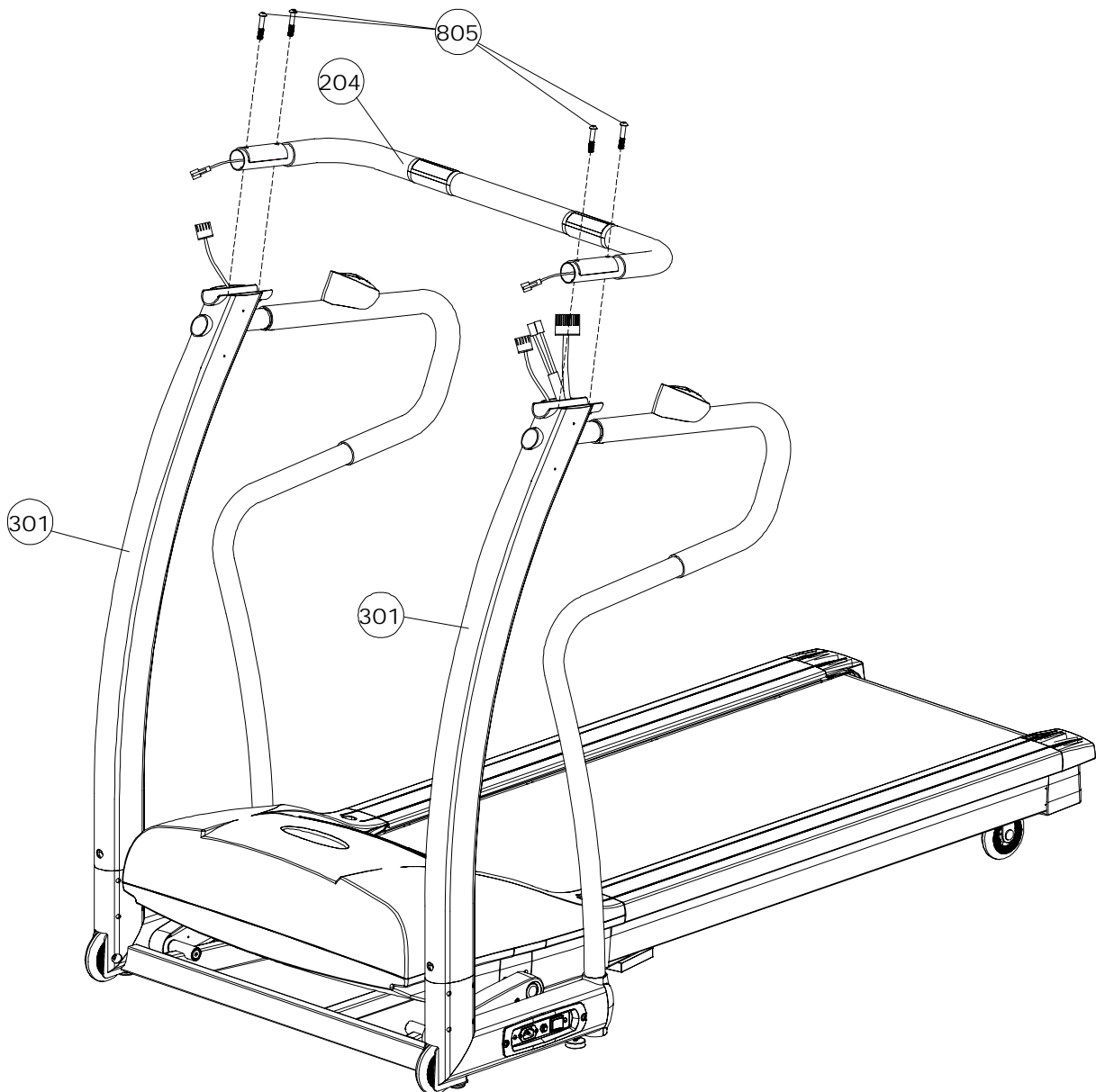
**X4**

**ASSEMBLY****Step 5: Attaching the Upright Covers**

NOTE: Be careful not to damage the wires when securing the Upright Covers.

- A) Attach the Right Upright Cover (304) to the right upright (303)
- B) Secure the Right Upright Cover with 2 #8x19mm Metal Screws (807).
- C) Repeat the above process for the left side

807 **x4** 

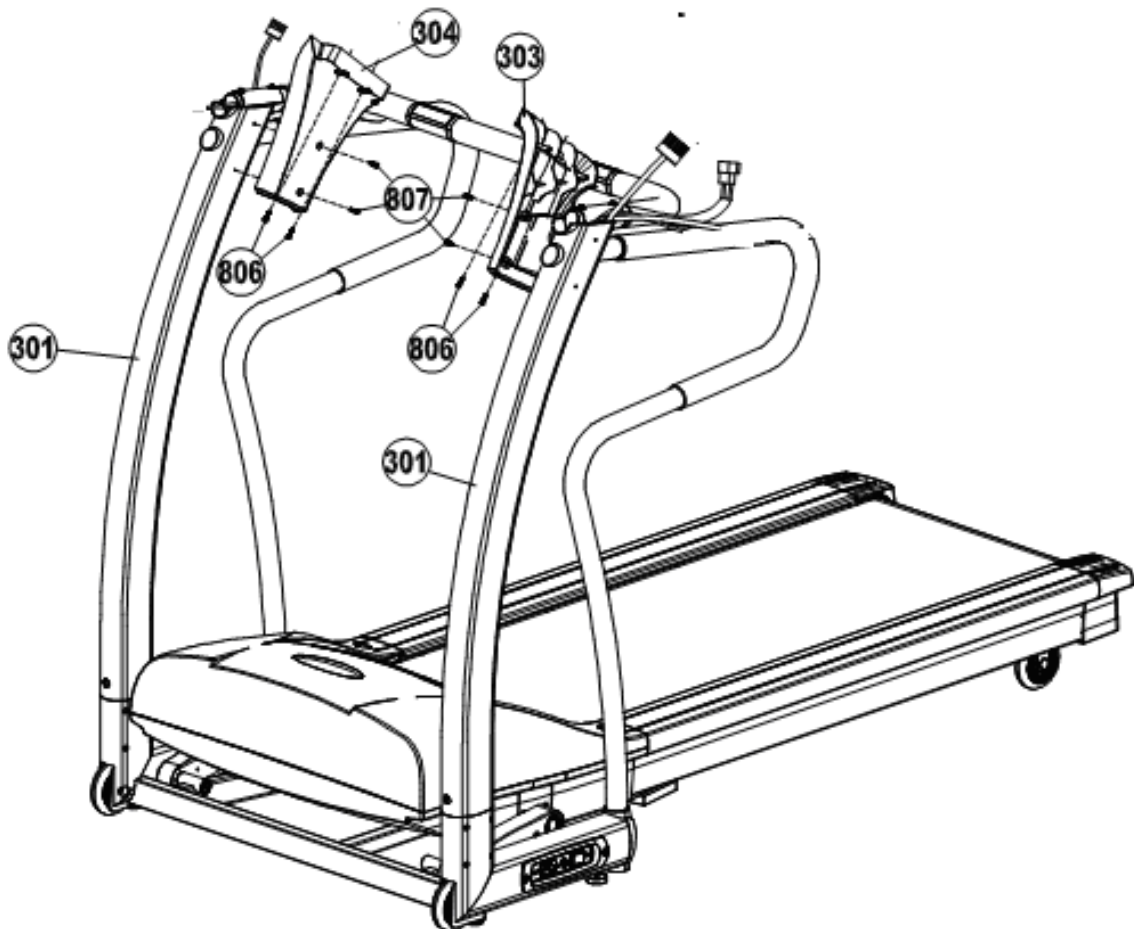

**ASSEMBLY****STEP 6: Attach the Computer**

- A) Lower the Console onto the Left and Right Upright Covers.
- B) Secure with four #8 x 19mm Screws (806)

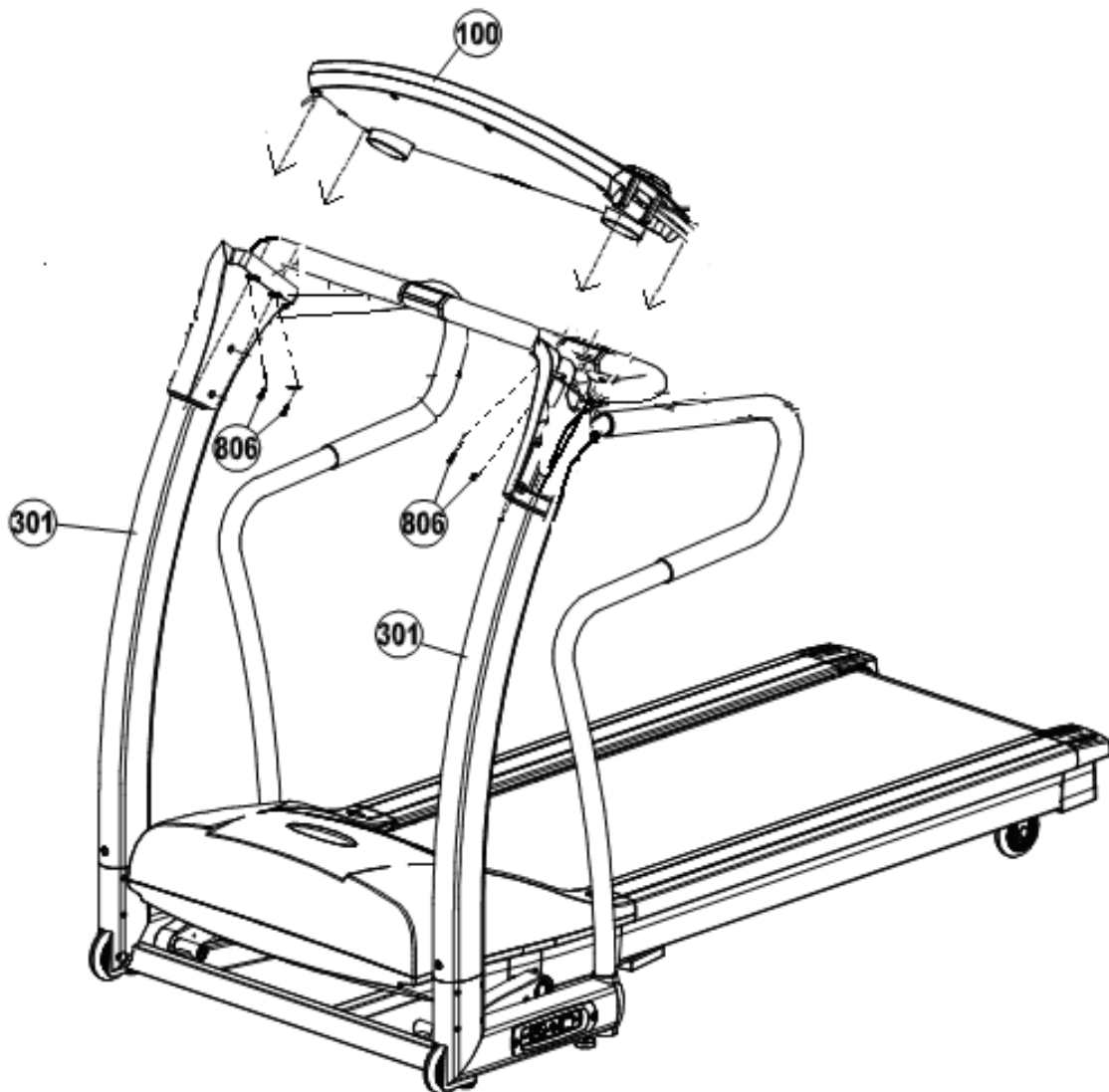
806 **X4** 



**ASSEMBLY****STEP 7: Connect Computer Cables**

- A) Make all the necessary computer connections as pictured below. The connectors are specially designed to only connect with the matching connectors.
- B) Before proceeding to the next steps recheck that all the cables are firmly connected

806 **X4** 

807 **x4** 

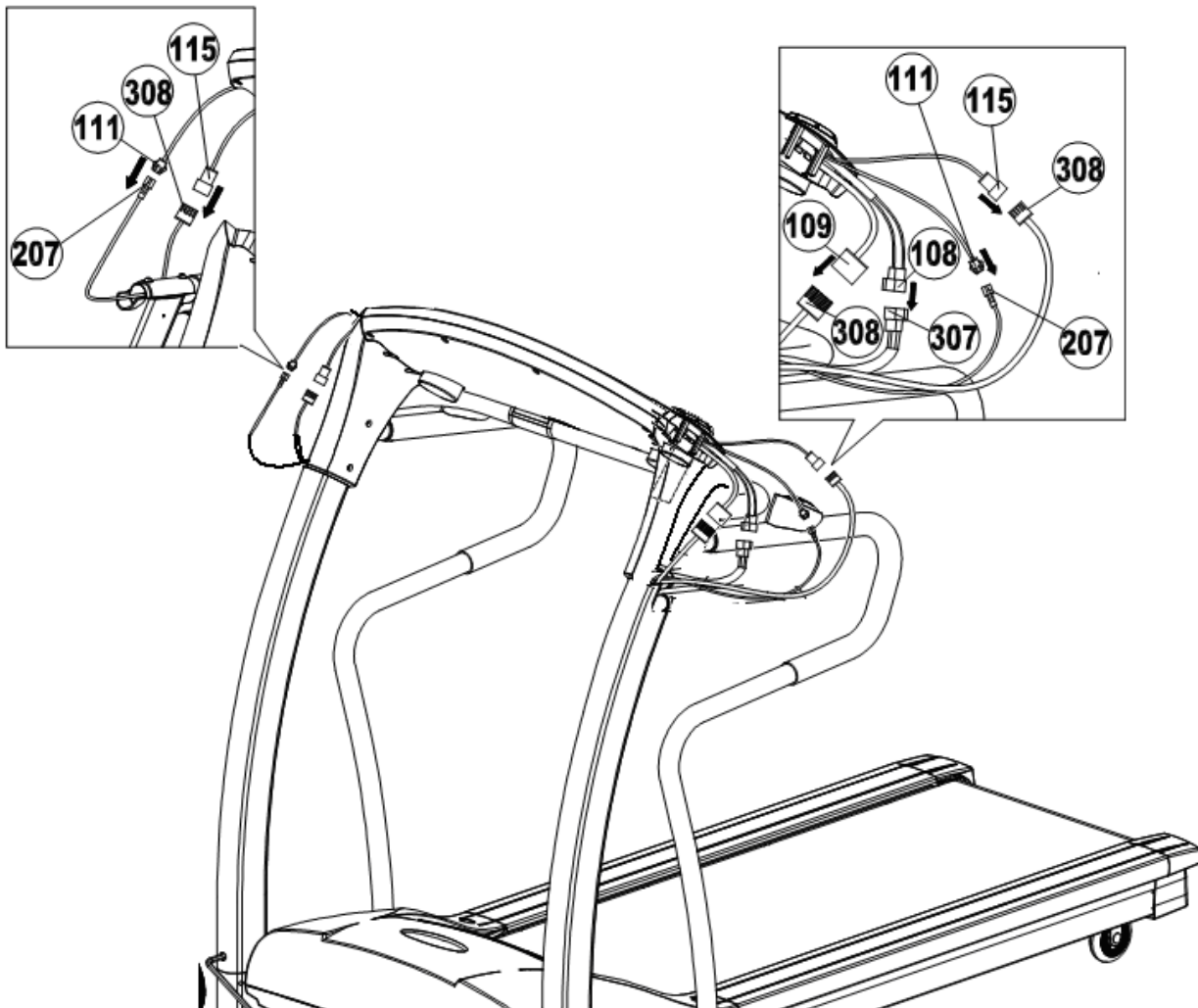

## ASSEMBLY

### STEP 8: Attach the Outside Upright Covers

Note: CAREFULLY FOLD THE COMPUTER CABLES AND TUCK THEM BETWEEN THE PLASTIC RIDGES OF PARTS 303 AND 304 SO THEY WILL NOT BE PINCHED

- A) Attach the Upright Cover (305) to the right side Upright Tube (301)
- B) Secure using two #8 x 19mm Screws (806) into the console.
- C) Then secure using two #8 x 19mm Metal Screws (807) into the Upright Tube
- D) Repeat this process for the left side

806 **X4** 

807 **X4** 

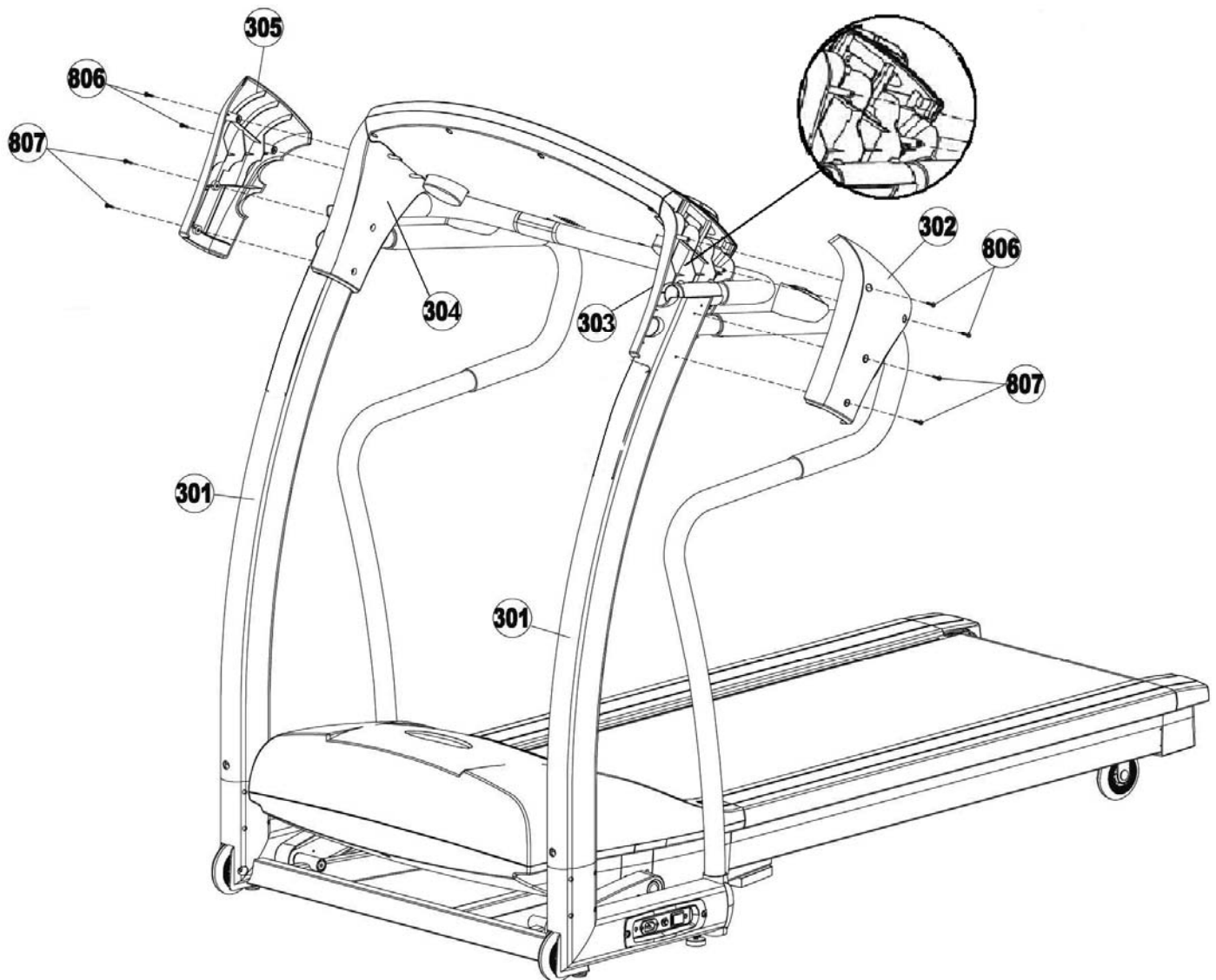

**ASSEMBLY****STEP 9: Securing of the Upright Tubes**

NOTE: ONLY TURN BOLTS CLOCKWISE. The Allen Bolt Sets (412) have been pre-assembled in the Base Frame (401)

Secure The Upright Tubes by tightening the Allen Bolt (412), located in the Upright Tube, clockwise.

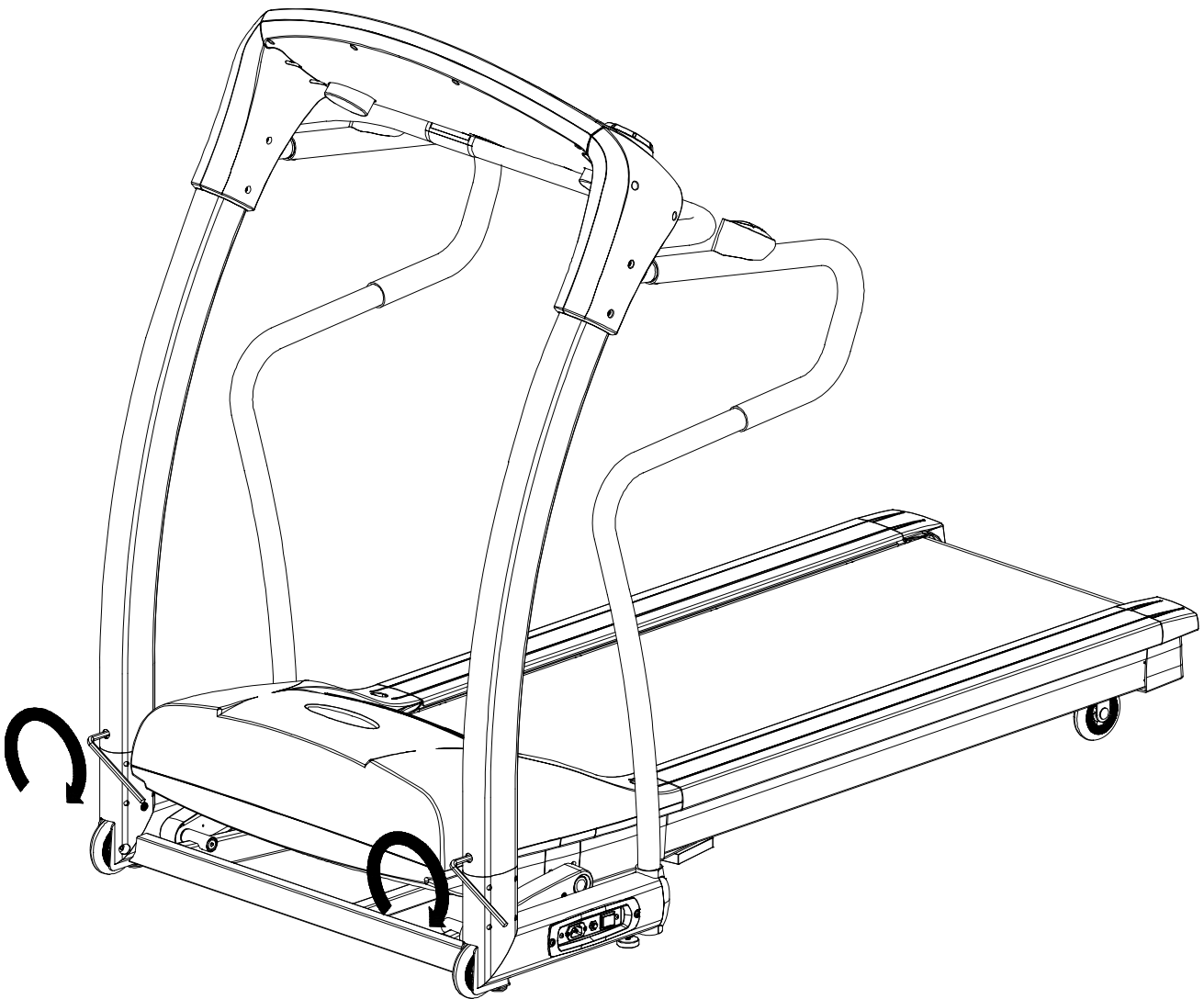

## STABILIZER ADJUSTMENT

### FOLLOW THESE INSTRUCTIONS TO LEVEL YOUR TREADMILL:

An uneven floor or improper stabilizer level can cause the treadmill to wobble during use as well as the incline adjustment to function incorrectly. Please follow the procedure described below to make sure the treadmill stabilizer is adjusted correctly prior to use. You may need the assistance of another person to perform this adjustment.

**First locate the two adjustable stabilizers under the base frame. Then simply rotate them in or out to adjust the level of the treadmill. When properly adjusted the treadmill should sit firmly on both stabilizers and all cushions.**

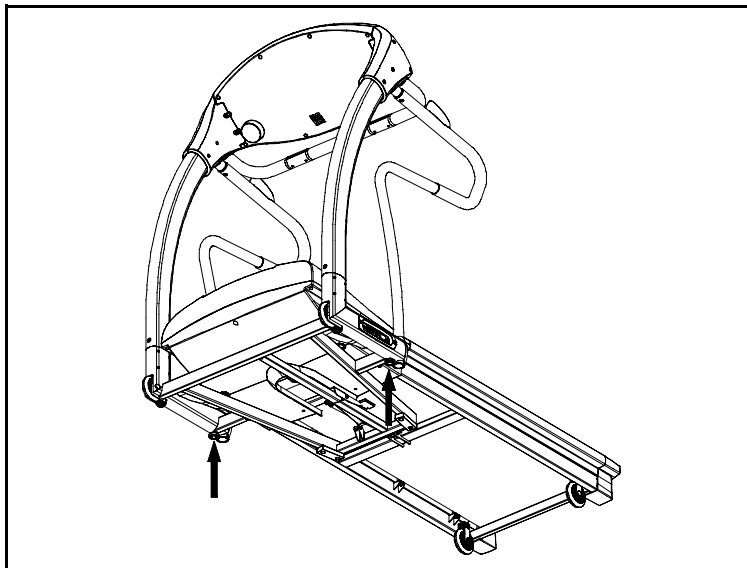

Locate the two adjustable stabilizers under the base frame.

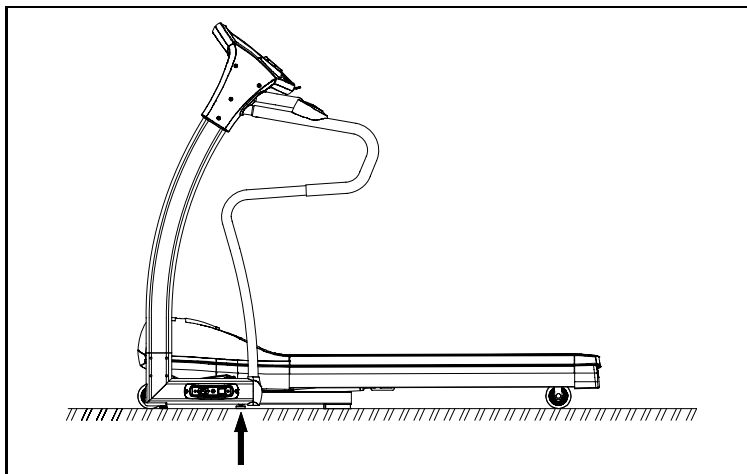

Treadmill should sit firmly on both stabilizers and all cushions.

## Features

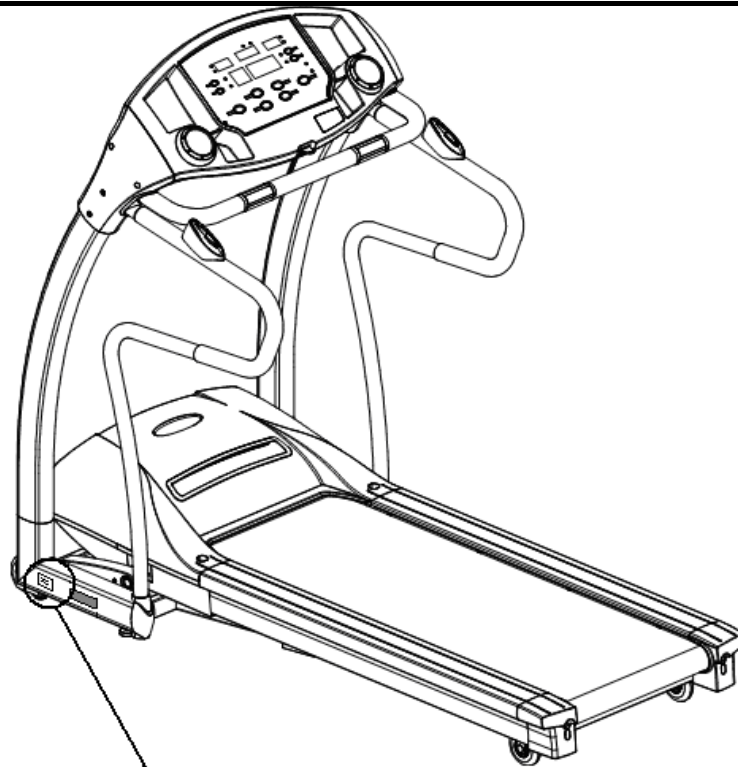

Serial Number Location

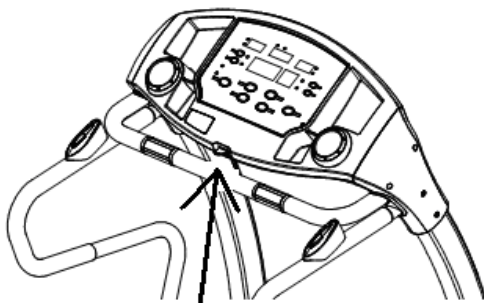

**Insert safety key**



The safety key must be inserted for the treadmill to function. The safety key clip should be worn at all times when the treadmill is in use. This safety feature is designed to prevent injury.

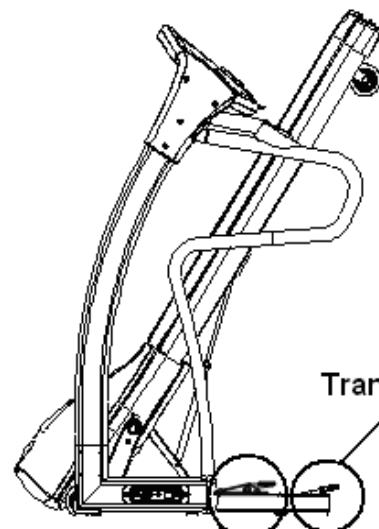

Transport wheel

Folding Lock

There are two orange levers on this treadmill. The most forward lever is the folding lock which is used in folding and unfolding this treadmill. The other is used for transporting from one location to another

## FOLDING INSTRUCTIONS

### How to fold up the treadmill:

Your treadmill can be folded up for space saving storage. To do this follow the instructions here:

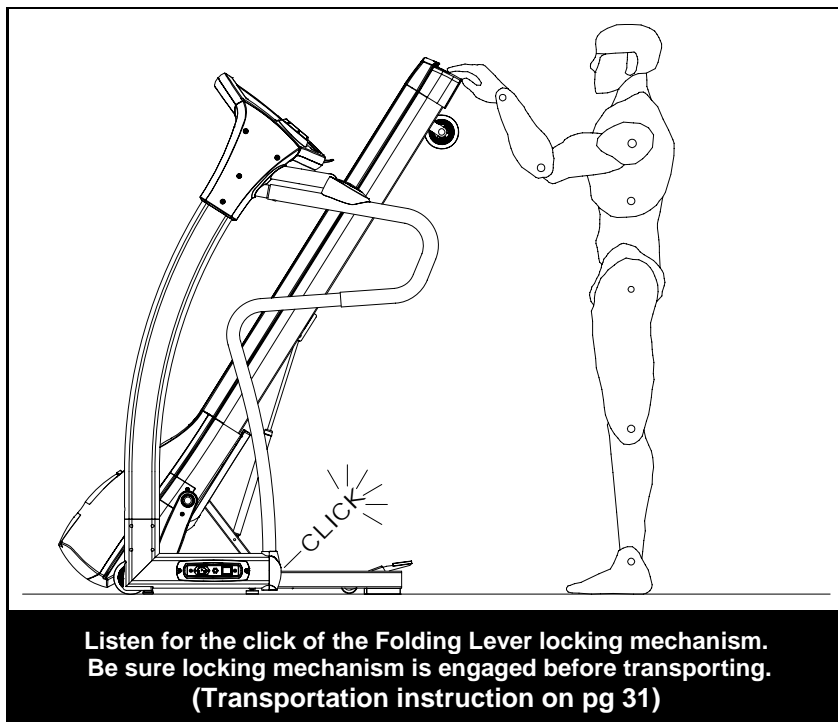
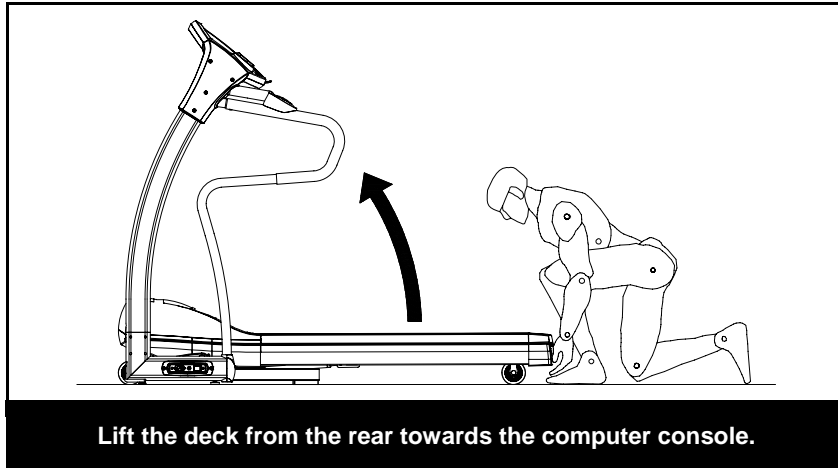

## UNFOLDING INSTRUCTIONS

### How to unfold the treadmill:

To unfold the treadmill for use follow the instructions here:

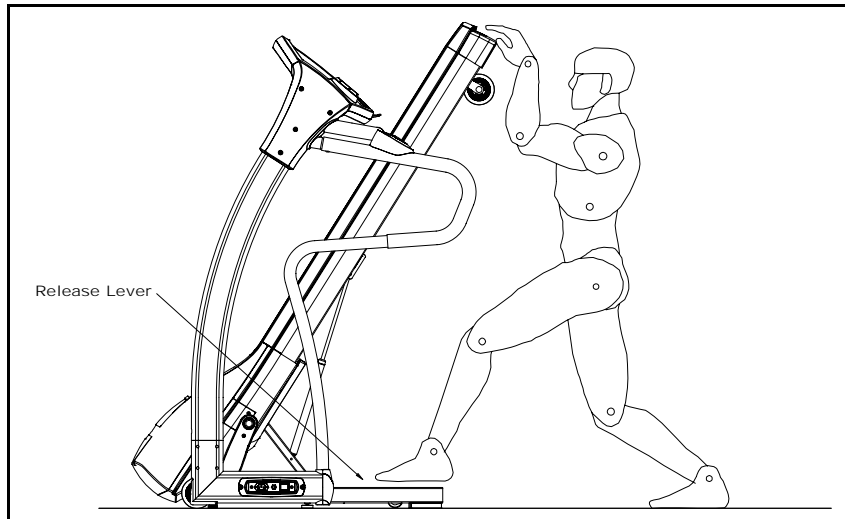

**Push the deck towards the computer console.  
Depress the Folding Lever begin lowering the treadmill  
towards the floor release the Folding Lever**

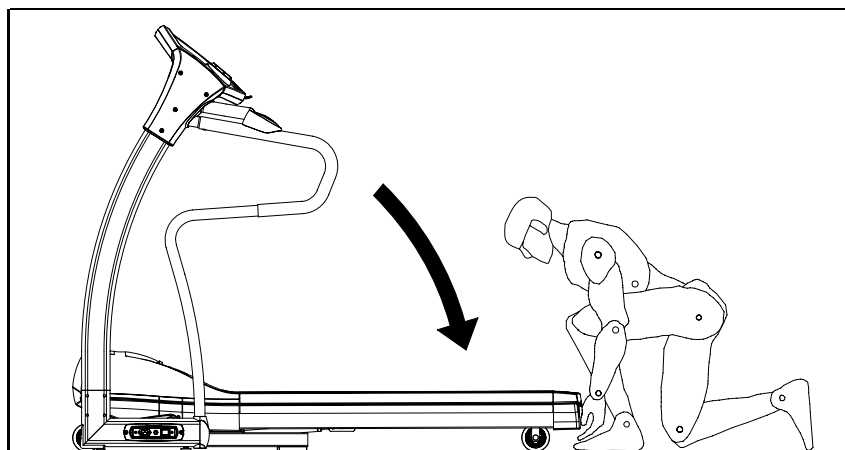

**Lower treadmill deck towards floor.**

## TRANSPORT INSTRUCTIONS

### TRANSPORT INSTRUCTIONS:

To roll away for storage simply grab the rear deck, lift slightly and roll to desired location.

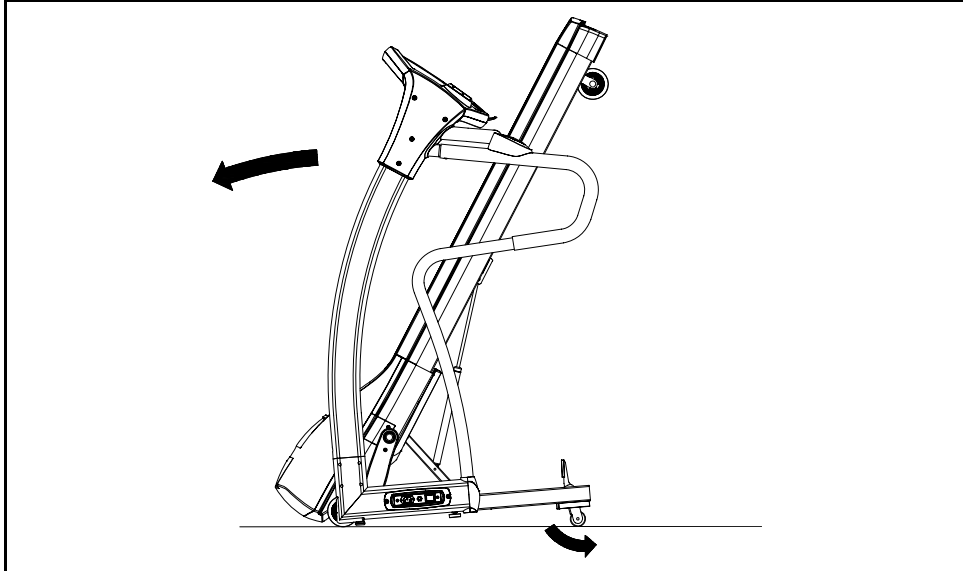

Lift the deck from the rear so that the treadmill rests on the front transportation wheels and rear transportation wheel engages

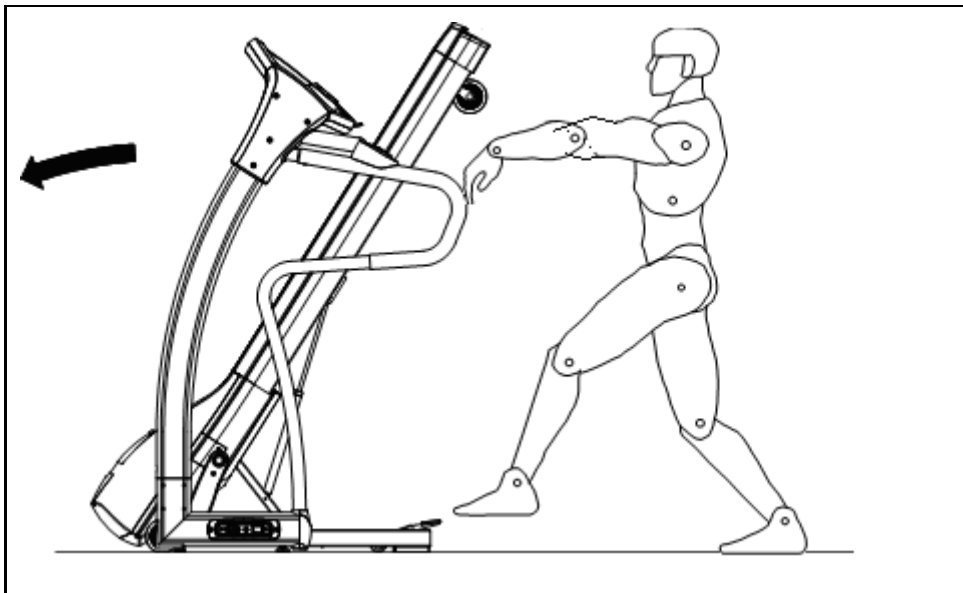

Roll to a desired location.



## MOTION CONTROL OPERATION

### MOTION CONTROL:

Walking belt speed can be increased, decreased or stopped using the Motion Control sensors on the handlebars. To do this follow the instructions below:

1. Press the  button on the console to switch the motion control function on and off:
  - When the LED light is **ON** the MOTION CONTROL is **active**.
  - When the LED light is **OFF** the MOTION CONTROL is **off**.
2. After switching on the MOTION CONTROL wave your right hand approximately 6 inches above the motion sensor on the right handle bar to increase the speed. The sensor will sound one short BEEP per scan and speed up by 0.1 MPH per BEEP. Holding your right hand approximately 6 inches above the right sensor constantly results in the sensor sounding one long BEEP per second and speeding up by 0.5 MPH per second.

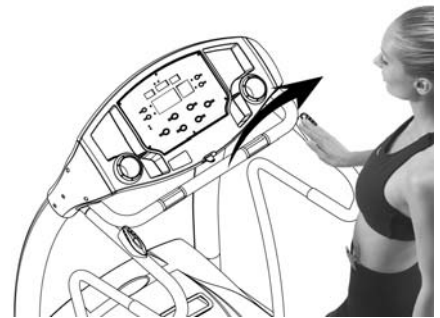

2. Use right sensor to speed up.

3. Wave your left hand approximately 6 inches above the motion sensor on the left handle bar to decrease the speed. The sensor will sound one short BEEP per scan and decrease speed by 0.1 MPH. Holding your left hand approximately 6 inches above the left sensor constantly results in the sensor sounding one long BEEP per second and decreasing speed by 0.5 MPH per second.



3. Use left sensor to slow down.

4. Wave both hands approximately 6 inches above both motion sensors at the same time. The sensor will sound two short BEEP sounds then stop the belt.
  - **Always switch off the motion control function by pressing the  MOTION CONTROL button on the console before turning off the power to the treadmill.**



4. Use both sensors to stop belt.

## MAINTENANCE

### HOW TO MAINTAIN THE EVO FX40HR TREADMILL:

Proper maintenance is very important to ensure your treadmill is always in top working condition. Improper maintenance could cause damage or shorten the life of your treadmill and exceed the LIMITED WARRANTY coverage.

- **Important: DO NOT** use abrasives or solvents to clean the treadmill. To prevent damage to the computer, keep liquids away and keep it out of direct sunlight.
- Inspect and tighten all parts of the treadmill regularly. Replace any damaged or worn parts immediately.

### BELT ADJUSTMENT:

ALL BELT ADJUSTMENTS ARE CONSIDERED MAINTENANCE, AND ARE THE RESPONSIBILITY OF THE END USER. Belt adjustment and tension performs two functions: adjustment for tension and centering. The running belt has been adjusted properly at the factory. However transportation, uneven flooring or other unpredicted reasons could cause the belt to shift off center resulting in the belt rubbing on the plastic side rail or end caps and possibly causing damage to the equipment. To adjust the belt back to it's proper position please follow the directions below:

- **Walking belt has shifted to the left:** First unplug the power cord from the surge protector. Using the hex key provided, turn the left rear roller adjustment bolt 1/4 turn in the clockwise direction. Plug the power cord back into the surge protector and run the treadmill at 2.5 mph. You should see the belt start to correct itself, moving back towards the center. Repeat the above procedure until the walking belt is centered. It may be necessary to set walking belt tension once you have completed this procedure if the belt feels like it is slipping while walking. Refer below to the "Walking belt slipping" instructions.
- **Walking belt has shifted to the right:** First unplug the power cord from the surge protector. Using the hex key provided, turn the right rear roller adjustment bolt 1/4 turn in the clockwise direction. Plug the power cord back into the surge protector and run the treadmill at 2.5 mph. You should see the belt start to correct itself, moving back towards the center. Repeat the above procedure until the walking belt is centered. It may be necessary to set walking belt tension once you have completed this procedure if the belt feels like it is slipping while walking. Refer below to the "Walking belt slipping" instructions.
- **Walking belt is slipping:** First unplug the power cord from the surge protector. Using the hex key provided, turn both the left and right rear roller adjustment bolts the equal amounts, 1/2 turn in the clockwise direction. Plug the power cord back into the surge protector and run the treadmill at 2.5 mph. You should now walk on the belt to determine if the belt is still slipping. Repeat the above procedure until the walking belt is not slipping. The tension should be just tight enough not to slip. If proper tension cannot be achieved within four attempts please contact Smooth Fitness Technical Support. Belt centering may be necessary once you have completed the tensioning procedure.

**WARNING! Do not over tighten rollers! This will cause premature roller bearing failure!**

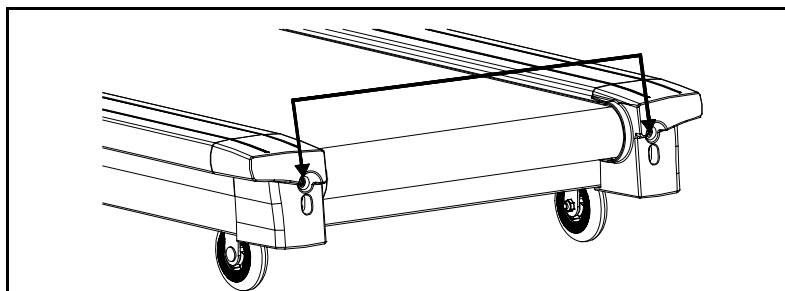

**Right and left tension bolts are located at the rear of the treadmill.**

## MAINTENANCE

### CLEANING:

Routine cleaning of your treadmill will extend the product's life.

- **Warning:** To prevent electrical shock, be sure the power to the treadmill is OFF and the power cord is unplugged from the wall electrical outlet before attempting any cleaning or maintenance.
- **Important: DO NOT** use abrasives or solvents to clean the treadmill. To prevent damage to the computer, keep liquids away and keep it out of direct sunlight.
- **After each workout:** Wipe off the console and other treadmill surfaces with a clean, water dampened soft cloth to remove excess perspiration.
- **Weekly:** Use of a treadmill mat is recommended for ease of cleaning. Dirt from your shoes contacts the belt and eventually makes it to underneath the treadmill. Vacuum underneath treadmill once a week.

### DECK LUBRICATION:

The walking belt has been pre-lubricated at the factory. However, it is recommended that the running deck be checked periodically for lubrication to ensure optimal treadmill performance. Your treadmill should not have to be lubricated usually within the first 400 hours of use.

Every 2 months of operation lift the sides of the walking belt and feel the top surface of the running deck as far as you can reach. If you feel signs of silicone, no further lubrication is required. If it feels dry to the touch, follow the instructions below.

To purchase lubricant Kit please contact Smooth Fitness 1-888-800-1167

#### To apply lubricant under the walking belt:

1. Position the walking belt so that the seam is located on top and in center of the walking board.
2. Insert the spray nozzle into the spray head of the lubricant can.
3. While lifting the side of the walking belt, position the spray nozzle between the walking belt and the board approximately 6" from the front of the treadmill and as far to the center as possible. Apply the silicone spray to the walking board, moving from the front of the treadmill to the rear. Repeat this on the other side of the belt. Spray approximately 1/4 bottle (supplied with treadmill) each time.

Allow the silicone to "set" for 1 minute before using the treadmill.

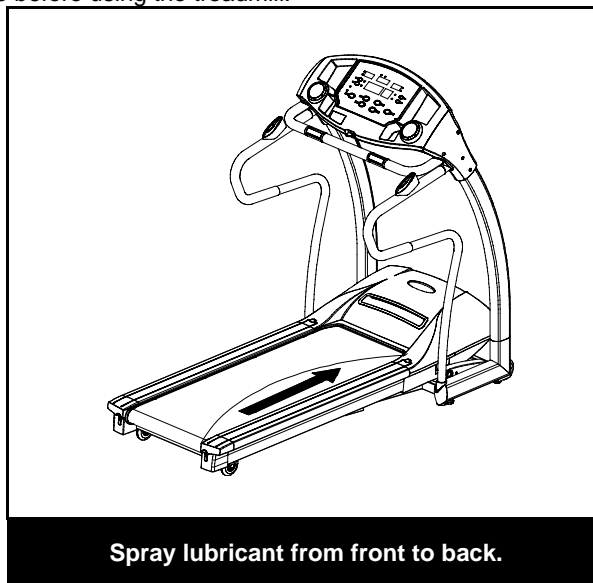

## IMPORTANT STEPS

### Warning:

Before using this product, please consult your personal physician for a complete physical examination. Frequent and strenuous exercise should be approved by your doctor first. If any discomfort should result from your use of this product, stop exercising and consult your doctor. Proper usage of this product is essential. Please read your manual carefully before exercising.

Please keep all children away from the equipment during use and when equipment is unattended.

Always wear appropriate clothing, including athletic shoes, when exercising. Do not wear loose clothing that could become caught during exercising.

Make sure that all bolts and nuts are tightened when equipment is in use. Periodic maintenance is required on all exercise equipment to keep it in good condition.

### Before beginning:

How you begin your exercise program depends on your physical condition. If you have been inactive for several years, or are severely overweight, you must start slowly and increase your time gradually, a few minutes per week.

Initially you may be able to exercise only for a few minutes in your target zone. However, your aerobic fitness will improve over the next six to eight weeks. Don't be discouraged if it takes longer. It's important to work at your own pace. Ultimately, you'll be able to exercise continuously for 30 minutes. And the better your aerobic fitness, the harder you will have to work to stay in your target zone. But remember these essentials:

- Contact your physician before starting a workout or training program. Have your doctor review your training and diet programs to advise you of a workout routine you should adopt.
- Begin your training program slowly with realistic goals that have been set by you and your doctor.
- Supplement your program with some type of aerobic exercise such as walking, jogging, swimming, dancing and/or bicycling. Monitor your pulse frequently. If you do not have an electronic heart rate monitor, have your physician show you the proper way to manually check your pulse by using your wrist or neck. Establish your target heart rate based on your age and condition.
- Drink plenty of fluids during the course of your routine. You must replace the water content lost from excessive exercising to avoid dehydration. Avoid drinking large amounts of cold liquids. Fluids should be at room temperature when consumed.



The Surgeon General  
has determined that lack  
of physical activity is  
detrimental to your health.™

## TARGET HEART RATE

### Finding your pulse:

To make sure your heart is beating in its target zone, you'll need to know how to monitor your heart rate. The easiest way is to feel the pulse in the carotid artery on either side of your neck, between the windpipe and the large neck muscles. Count the number of beats in ten seconds, and then multiply that number by six. This gives you the number of beats per minute.

How fast should your heart beat during aerobic exercise? Fast enough to reach and stay in its "target zone," a range of beats per minute that is largely determined by your age and physical condition. To determine your target zone, consult the chart we have provided.

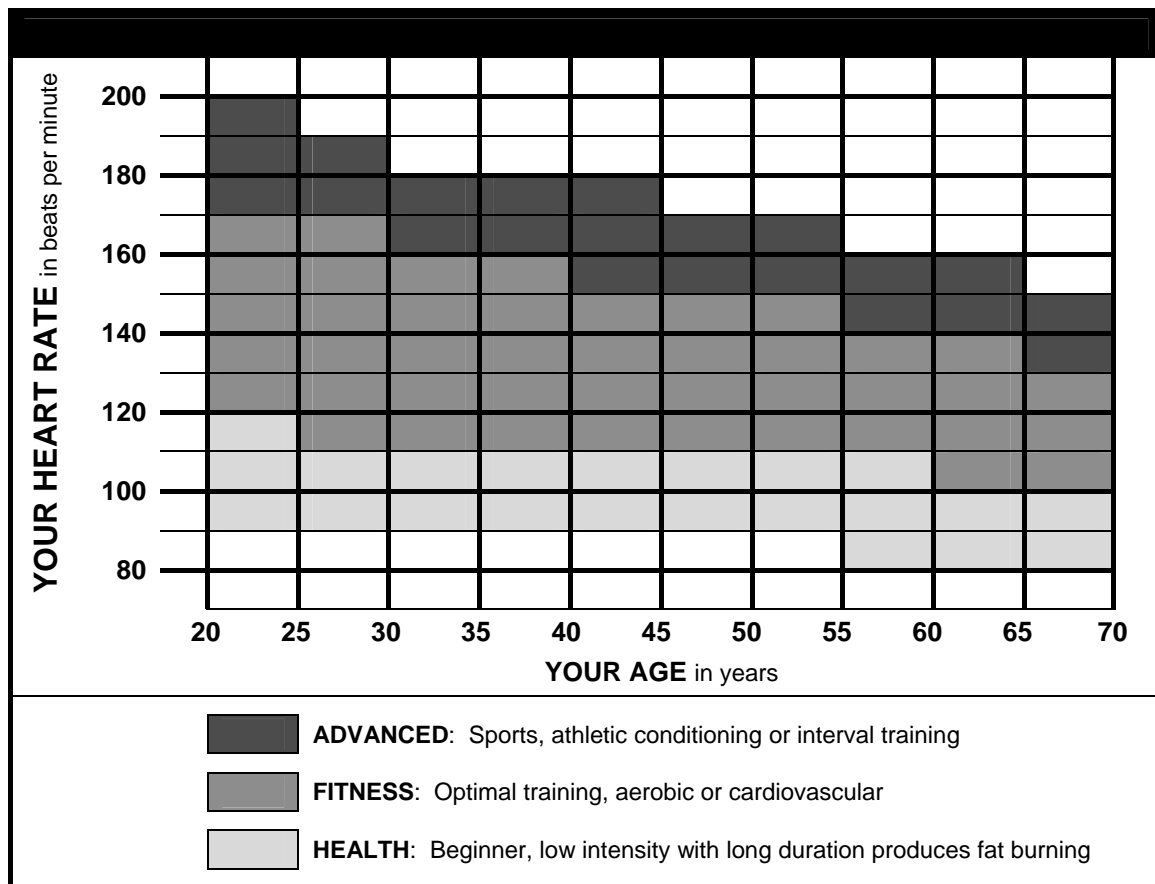

### Aerobic exercise:

Is any sustained activity that sends oxygen to your muscles via your heart and lungs. It will improve the fitness of your lungs and heart: your body's most important muscle. Aerobic fitness is promoted by any activity that uses your large muscle groups - arms, legs or buttocks, for example. Your heart beats quickly and you breathe deeply. An aerobic exercise should be part of your entire exercise routine.







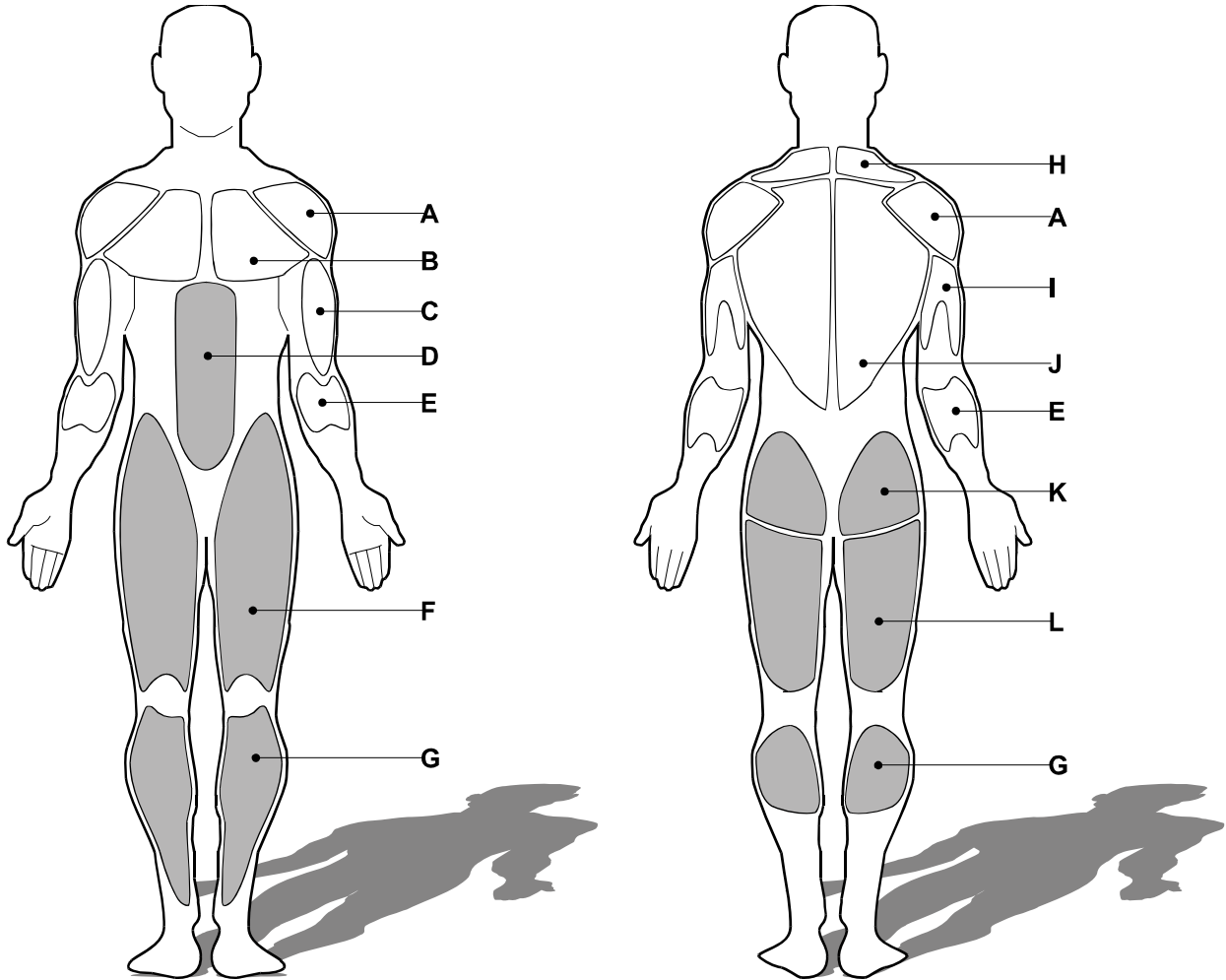





## MUSCLE CHART

### Targeted muscle groups:

The exercise routine that is performed on this product will develop primarily lower body muscle groups. These muscle groups are shown in gray color on the chart below.



### MUSCLE GROUPS

	Shoulder muscles		Calf muscles
	Pectoral muscles		Trapezius muscles
	Bicep muscle		Tricep muscles
	Abdominal muscles		Back muscles
	Forearm muscles		Gluteal muscles
	Quadricep muscles		Hamstring muscles

## STRETCHING ROUTINE

### Warm up and cool down:

A successful exercise program consists of a warm-up, aerobic exercise, and a cool-down. Do the entire program at least two and preferably three times a week, resting for a day between workouts. After several months, you can increase your workouts to four or five times per week.

Warming up is an important part of your workout, and should begin every session. It prepares your body for more strenuous exercise by heating up and stretching out your muscles, increasing your circulation and pulse rate, and delivering more oxygen to your muscles. At the end of your workout, repeat these exercises to reduce sore muscle problems. We suggest the warm-up and cool-down exercises on the following pages:

Slowly bend forward from your waist, letting your back and shoulders relax as you stretch toward your toes. Reach down as far as you can and hold for 15 counts.

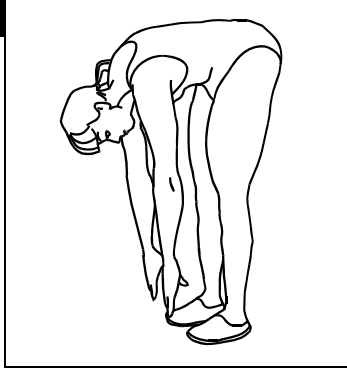

Lift your right shoulder up toward your ear for one count. Then lift your left shoulder up for one count as you lower your right shoulder.

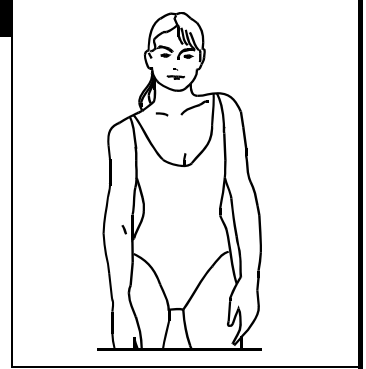

Sit with the soles of your feet together with your knees pointing outward. Pull your feet as close into your groin as possible. Gently push your knees towards the floor. Hold for 15 counts.

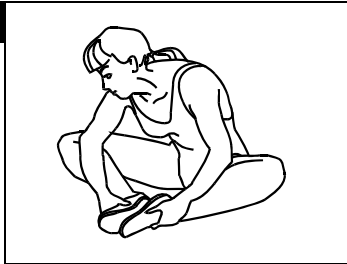

Sit with your right leg extended. Rest the sole of your left foot against your right inner thigh. Stretch toward your toe as far as possible. Hold for 15 counts. Relax and then repeat with left leg extended.

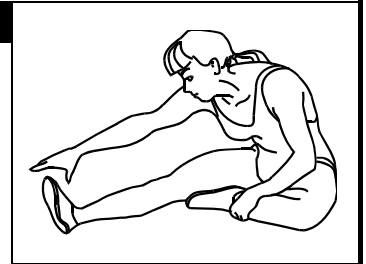

Open your arms to the side and continue lifting them until they are over your head. Reach your right arm as far upward toward the ceiling as you can for one count. Feel the stretch up your right side. Repeat this action with your left arm.

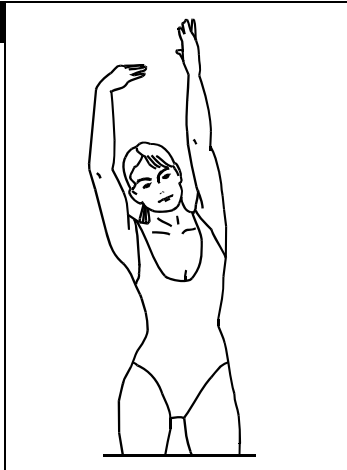

Lean against a wall with your left leg in front of the right and your arms forward. Keep your right leg straight and the left foot on the floor; then bend the left leg and lean forward by moving your hips toward the wall. Hold, and then repeat on the other side for 15 counts.

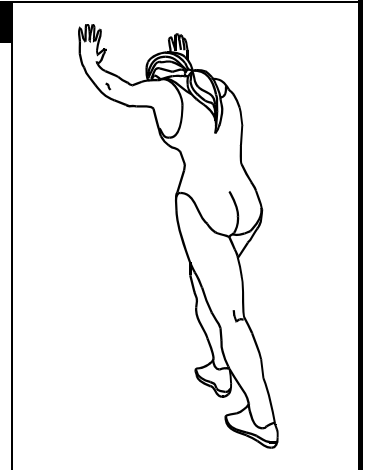

Rotate your head to the right for one count, feeling the stretch up the left side of your neck. Next, rotate your head back for one count, stretching your chin to the ceiling and letting your mouth open. Rotate your head to the left for one count, and finally, drop your head to your chest for one count.

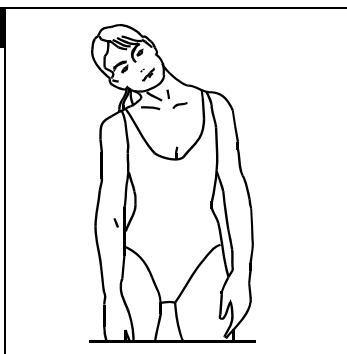

## TROUBLESHOOTING

**NOTE:** Do not touch any internal electric wires without consulting the manufacturer.

**Treadmill will not start:**

Symptom	Resolution
Treadmill will not power up	Check the following:
	<ul style="list-style-type: none"> <li>▪ Make sure the power cord is plugged into a surge protector, the surge protector is plugged into a properly grounded outlet and the surge protector is turned on (refer to the Power Requirements section in this manual).</li> </ul>
	<ul style="list-style-type: none"> <li>▪ Equipment circuit breaker is in the reset position</li> </ul>
	<ul style="list-style-type: none"> <li>▪ Equipment power switch is in the on position</li> </ul>
	<ul style="list-style-type: none"> <li>▪ Safety key is properly inserted into the computer console</li> </ul>
	<ul style="list-style-type: none"> <li>▪ Wall outlet is properly functioning with correct voltage (Have an electrician check for inadequate voltage at the outlet refer to the Power Requirements section in this manual)</li> </ul>
Treadmill stops operation during use	<ul style="list-style-type: none"> <li>▪ House circuit breaker is reset and is the proper size. (refer to the Power Requirements section in this manual)</li> </ul>
	<ul style="list-style-type: none"> <li>▪ Safety key is properly inserted into the computer console</li> </ul>
	<ul style="list-style-type: none"> <li>▪ Equipment circuit breaker is in the reset position</li> </ul>
	<ul style="list-style-type: none"> <li>▪ House circuit breaker is reset, meets proper requirements and if worn replaced by an electrician. (refer to the Power Requirements section in this manual)</li> </ul>
Treadmill will not incline(Power fold models only)	<ul style="list-style-type: none"> <li>▪ Program time has expired</li> </ul>
Treadmill will not unfold	<ul style="list-style-type: none"> <li>▪ Check for proper positioning of spring knob for folding(See procedure in owners manual)</li> </ul>
	Power Fold only <ul style="list-style-type: none"> <li>▪ Check for proper positioning of spring knob for folding(See procedure in owners manual)</li> </ul> Manual Fold only <ul style="list-style-type: none"> <li>▪ Folding locking lever is depressed</li> </ul>
Treadmill running belt moves slower than speed displayed on computer	<ul style="list-style-type: none"> <li>▪ Metric/English conversion (See owners manual for Metric/English conversion process)</li> </ul>
Treadmill running belt moves slower than speed displayed on computer	<ul style="list-style-type: none"> <li>▪ Metric/English conversion (See owners manual for Metric/English conversion process)</li> </ul>
Running belt is not centered	<ul style="list-style-type: none"> <li>▪ Treadmill is properly leveled(See procedure in owners manual)</li> </ul>
	<ul style="list-style-type: none"> <li>▪ Center running belt (See Centering procedure in owners manual)</li> </ul>
Running belt is slipping or hesitating while in use	<ul style="list-style-type: none"> <li>▪ Tension running belt (See process in owners manual)</li> </ul>
Treadmill running belt moves slower than speed displayed on computer	<ul style="list-style-type: none"> <li>▪ Metric/English conversion (See owners manual for Metric/English conversion process)</li> </ul>
Running belt is not centered	<ul style="list-style-type: none"> <li>▪ Treadmill is properly leveled(See procedure in owners manual)</li> </ul>
	<ul style="list-style-type: none"> <li>▪ Center running belt (See Centering procedure in owners manual)</li> </ul>
Running belt is slipping or hesitating while in use	<ul style="list-style-type: none"> <li>▪ Tension running belt (See process in owners manual)</li> </ul>





Smooth Fitness  
780 Fifth Avenue Suite 200  
King of Prussia, PA 19406

Toll Free Customer Service:  
**1.888.800.1167**

Website:  
[www.evofitness.com](http://www.evofitness.com)

## Free Manuals Download Website

<http://myh66.com>

<http://usermanuals.us>

<http://www.somanuals.com>

<http://www.4manuals.cc>

<http://www.manual-lib.com>

<http://www.404manual.com>

<http://www.luxmanual.com>

<http://aubethermostatmanual.com>

Golf course search by state

<http://golfingnear.com>

Email search by domain

<http://emailbydomain.com>

Auto manuals search

<http://auto.somanuals.com>

TV manuals search

<http://tv.somanuals.com>