

EXB-8500 and EXB-8500c 8mm
Cartridge Tape Subsystems

Installation and Operation

 **Exabyte**[®]

306216-000

Copyright

Copyright 1993 by Exabyte Corporation. All rights reserved. This item and the information contained herein are the property of Exabyte Corporation. No part of this document may be reproduced, transmitted, transcribed, stored in a retrieval system, or translated into any language or computer language in any form or by any means, electronic, mechanical, magnetic, optical, chemical, manual, or otherwise, without the express written permission of Exabyte Corporation, 1685 38th Street, Boulder, Colorado 80301.

Disclaimer

Exabyte Corporation makes no representation or warranties with respect to the contents of this document and specifically disclaims any implied warranties of merchantability or fitness for any particular purpose. Further, Exabyte Corporation reserves the right to revise this publication without obligation to notify any person or organization of such revisions or changes.

Trademark Notices

AMP is a trademark of AMP Incorporated. Beckman Industrial is a trademark of Emerson Electric Company. Dale is a registered trademark of Dale Electronics, Inc. dataMate is a registered trademark of Methode Electronics, Inc. EXABYTE is a registered trademark and EXATAPE is a trademark of Exabyte Corporation. Molex is a registered trademark of Molex Incorporated. All other product names are trademarks or registered trademarks of their respective companies.

Revision History

Revision	Date	Description
000	December 1993	Initial release

Exabyte Corporation
1685 38th Street
Boulder, CO 80301
Phone: (303) 442-4333
Fax: (303) 442-7170

306216-000

Agency Standards

When properly installed with a shielded enclosure, shielded cable, and adequate grounding the of the SCSI bus and the input power, the EXB-8500 and EXB-8500c meet the following safety standards: UL Standard 1950, 1st Edition, Information Technology Equipment; CAN/CSA Standard C22.2 No. 950-M-89, Safety of Information Technology Equipment; and IEC 950/EN60950, Safety of Information Technology Equipment including Electrical Business Equipment (TUV).

FCC Notice

This equipment has been tested and found to comply with the limits for a Class B digital device pursuant to Part 15 of FCC rules. These limits are designed to provide reasonable protection against harmful interference in a residential installation. This equipment generates, uses, and can radiate radio frequency energy and, if not installed and used in accordance with the instructions, may cause interference to radio and television communications. There is no guarantee, however, that interference will not occur in a particular installation. If this equipment does cause interference to radio or television reception, which can be determined by turning the equipment off and on, the user is encouraged to try to correct the interference by one or more of the following measures:

- Reorient or relocate the receiving antenna.
- Increase the separation between the equipment and receiver.
- Connect the equipment into an outlet on a circuit different from that to which the receiver is connected.
- Consult the dealer or an experienced radio/TV technician for help and for additional suggestions.

Changes or modifications not expressly approved by Exabyte Corporation could void the user's authority to operate the equipment.

CDC Notice

This digital apparatus does not exceed the Class B limits for radio noise emissions from digital apparatus set out in the Radio Interference Regulation of the Canadian Department of Communication.

Product Warranty Caution

The EXB-8500 and EXB-8500c 8mm Cartridge Tape Subsystems (tape drives) are warranted to be free from defects in materials, parts, and workmanship and will conform to the current product specifications upon delivery. **For the specific details of your warranty, refer to your sales contract or contact the company from which the tape drive was purchased.**

The warranty for the tape drive shall not apply to failures caused by:

- Physical abuse or use not consistent with the operating instructions or product specifications provided by Exabyte's personnel or agent for the applicable equipment.
- Modifications by other than Exabyte's personnel or agent in any way other than those approved by Exabyte, provided the warranty shall not be voided by the repair or replacement of parts or the attachment of items in the manner described in maintenance or installation instructions provided by Exabyte.
- Repair by other than Exabyte's personnel or agent in a manner contrary to the maintenance instructions provided by Exabyte.
- Removal of the Exabyte serial number tag.
- Physical abuse due to improper packaging of returns.

CAUTION

Returning the tape drive in unauthorized packaging may damage the unit and void the warranty. Refer to the packing instructions in this book for information.

If problems with the EXB-8500 or EXB-8500c occur, contact your vendor; do not void the product warranty by allowing untrained or unauthorized personnel to attempt repairs.

Contents

Welcome	7
About This Guide	8
Conventions Used in This Guide	8
For More Information	8
1 Installing the Tape Drive	9
Unpacking the Tape Drive	10
Ensuring ESD Protection	10
Setting the SCSI ID	11
Preparing the Tape Drive for the SCSI Bus	14
Installing the Tape Drive in a PC Drive Bay	17
Performing the Initial Power On	20
2 Operating the Tape Drive	23
Reading the LEDs	23
Selecting Data Cartridges	25
Setting the Write-Protect Switch	26
Loading a Data Cartridge	27
Unloading a Data Cartridge	27
3 Preventive Maintenance	29
Determining When to Clean the Tape Drive	29
Using the 8mm Cleaning Cartridge	30
Caring for Data Cartridges	31
Replacing Data Cartridges	32
4 Packing the Tape Drive	33
Packing the Tape Drive for Shipment	34
Environmental Requirements for Shipment	35
Appendix A Installation Requirements	37
SCSI Cable Requirements	37
SCSI Cable Connector	38
Attaching the Tape Drive to a Frame	38
Chassis Grounding (optional)	40
Power Cable Connector	40
Appendix B Tape Drive Specifications	42
Index	43

WELCOME

Thank you for selecting the EXABYTE® EXB-8500 or EXB-8500c 8mm Cartridge Tape Subsystem (tape drive). The EXB-8500 and the EXB-8500c (shown below) are high-capacity, high-performance, and highly reliable streaming tape drives for PC, super-mini, and mainframe computer systems. Packaged in a standard 5.25-inch form-factor, the EXB-8500c and EXB-8500 are identical on the outside except for the letter “c” on the EXB-8500c’s front panel unload button.

The EXB-8500 provides up to 5.0 GBytes of data storage capacity on a single, standard 112m EXATAPE™ 8mm Data Cartridge. Using an average data compression ratio of 2:1, the EXB-8500c can store up to 10.0 GBytes of data on an 8mm data cartridge.

The tape drive incorporates a single-ended or differential Small Computer System Interface (SCSI) controller and is ideally suited for back-up and restore tasks, data archiving, and data file interchange.

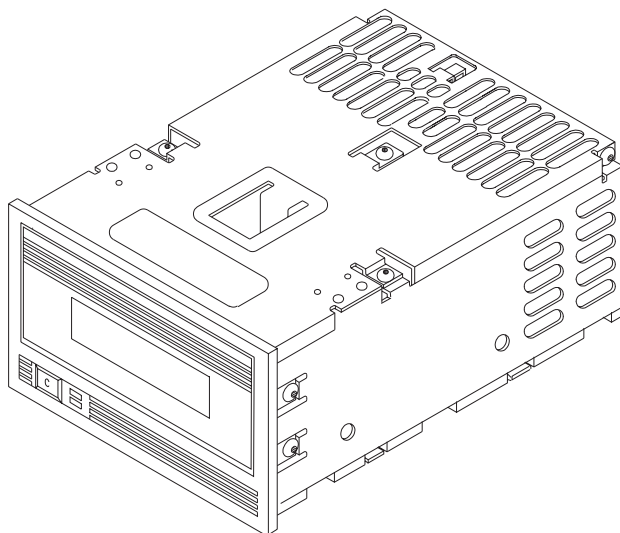

About This Guide

Use this guide as you install and operate the tape drive. In addition to instructions for installation and operation, this guide provides information about selecting and maintaining data cartridges, cleaning the tape drive, and packing the tape drive for shipment.

Conventions Used in This Guide

This guide uses the following conventions to highlight special information:

Note: *Notes* provide hints or suggestions about the topic or procedure being discussed.

Important

Information in *Important* boxes will help you successfully complete a procedure or avoid additional steps in a procedure.

CAUTION

Information in *Caution* boxes explains how to avoid damaging the tape drive, the data cartridge, other equipment, or data recorded on tape.

For More Information

For tape drive specifications, refer to the *EXB-8500 and EXB-8500c 8mm Cartridge Tape Subsystems Product Specification* (510200). For information about programming SCSI commands for the tape drive, refer to the *EXB-8500 8mm Cartridge Tape Subsystem User's Manual* (510201) or the *EXB-8500c 8mm Cartridge Tape Subsystem User's Manual* (510209).

1 Installing the Tape Drive

This section provides instructions for the following tasks:

- Unpacking the tape drive and ensuring ESD protection (page 10)
- Setting the SCSI ID (page 11)
- Preparing the tape drive for the SCSI bus (page 14)
- Installing the tape drive in a PC drive bay (page 17)
- Connecting the tape drive to the power supply (page 20)
- Performing the initial power on (page 20)

Table 1 lists the tools and equipment you will need.

Table 1 Tools and equipment for installing the CTS

Required Tools and Equipment	
SCSI cable (not provided)	See page 37 for SCSI cable requirements.
Power cable	See page 40 for power cable requirements.
Power supply	See page 42 for power specifications.
Optional Tools and Equipment	
SCSI ID jumpers or remote switch	Use a female Molex [®] 22-55-2061 (or equivalent) cable connector on the remote switch cable.
External SCSI bus terminator (not provided)	Differential tape drive: If the tape drive terminates the SCSI bus, use a Methode Electronics, Inc. dataMate [®] DM103-01-0 (or equivalent) differential external terminator. Single-ended tape drive: If the tape drive terminates the SCSI bus, you can remove the tape drive's internal terminators (R-packs) and use a dataMate DM103-02-0 (or equivalent) single-ended external terminator.
Mounting frame or brackets, four #6-32 screws, screwdriver	Depending on your installation requirements, can be used to mount the tape drive.
Flat-nose wiring pliers	Can be used to remove the R-packs from a single-ended tape drive. See page 15.

¼-inch female spade connector or M3-0.5 6 mm self-tapping screw	Can be used for additional chassis grounding.
--	---

Unpacking the Tape Drive

The tape drive's packaging is designed to protect the tape drive from shock, vibration, moisture, and electrostatic discharge (ESD). Save all original packaging in case you need to repack or ship the tape drive.

CAUTION

If the temperature of the room in which you are unpacking the tape drive differs from the storage location by 15° C (27° F) or more, let the tape drive acclimate in its packaging to the room environment for at least 12 hours before opening the box. This helps prevent condensation damage to the drive.

After you unpack the tape drive, check the contents of the carton against the packing list and inspect the tape drive for possible damage. If a part is missing or the tape drive is damaged, notify the carrier and your vendor immediately.

Note: If the tape drive has been stored for more than six months, follow the instructions on page 21 when applying power for the first time. (Check the MLCH label on the top of the tape drive to find out when the tape drive was manufactured.)

Ensuring ESD Protection

Follow these procedures to protect the tape drive from electrostatic discharge (ESD):

- Leave the tape drive in its antistatic bag until you are ready to install it.
- Use an antistatic mat and grounded static protection wristband. If a mat and wristband are unavailable,

discharge static electricity from your body before handling the tape drive. (Touch a known grounded surface, such as your computer's metal chassis.)

- If you must lay the tape drive down, place it into or on top of the antistatic bag.

Setting the SCSI ID

After unpacking the tape drive, you can change the tape drive's default SCSI ID, if necessary. Do not use SCSI ID 7. This SCSI ID is used by your SCSI adapter card.

You can use any of the following methods to set the ID:

- Set the DIP switches on the rear of the tape drive.
- Attach jumpers (shunts) to the pins on the tape drive's SCSI ID jumper block. Jumpers are already installed on the jumper block when the tape drive is shipped.
- Connect a remote switch to the SCSI ID jumper block on the back of the tape drive.

These methods are explained in the following sections.

Important

If you are using a remote switch or jumpers to set the SCSI ID, make sure that the DIP switches are set to SCSI ID 0 (the default). Similarly, if you are using the DIP switches to set the SCSI ID, make sure that the remote switch or jumpers are set to SCSI ID 0.

If you set both the DIP switches and the remote switch to a particular SCSI ID, the actual SCSI ID will be the logical OR of the two settings. For example, if the remote switch is set for SCSI ID 1 and the DIP switches are set for SCSI ID 2, the actual SCSI ID will be 3.

Setting the SCSI ID with the DIP Switches

To set the SCSI ID using the DIP switches, follow these steps:

1. Locate the SCSI ID DIP switches on the back of the tape drive, as shown in Figure 1.
2. Change the DIP switch settings to the correct SCSI ID for your configuration. Figure 2 shows the settings for SCSI IDs 0 through 7.
3. Make sure that the remote switch or jumpers are set to SCSI ID 0.

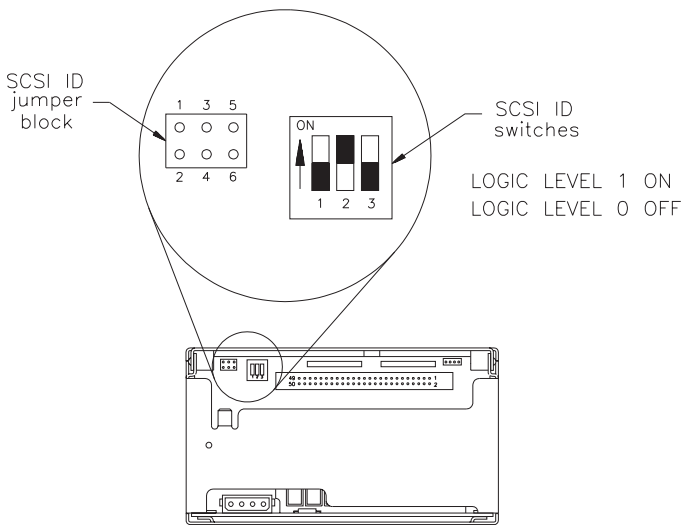

Figure 1 SCSI ID DIP switches and jumper block

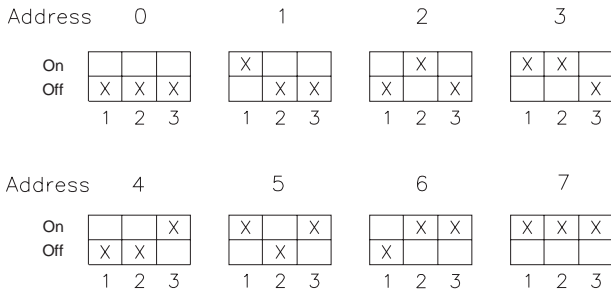

Figure 2 DIP switch settings for the tape drives's SCSI

Setting the SCSI ID with Jumpers

To set the SCSI ID using jumpers, follow these steps:

1. Locate the SCSI ID jumper block on the back of the tape drive, as shown in Figure 1.
2. Install the jumpers on the jumper block to obtain the correct SCSI ID for your configuration. Figure 3 shows how to position the jumpers for SCSI IDs 0 through 7.
3. Make sure that the DIP switches are set to SCSI ID 0.

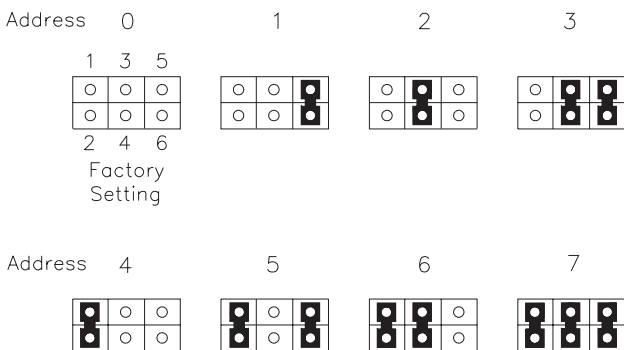

Figure 3 Jumper settings for the tape drive's SCSI ID

Setting the SCSI ID with a Remote Switch

If you want to set the SCSI ID remotely, you can attach a remote switch assembly (not provided with the tape drive) to the tape drive's SCSI ID jumper block. To set the SCSI ID with a remote switch, follow these steps:

1. Locate the SCSI ID jumper block on the back of the tape drive, as shown in Figure 1.
2. If necessary, remove the jumpers from the pins.
3. Connect a remote switch to the jumper block. Ensure that the remote switch is no more than 30.5 cm (12 inches) from the jumper block. See Table 1 on page 9 for connector requirements.
4. Make sure that the DIP switches (Figure 1) are set to a SCSI ID of 0.
5. Change the settings on the remote switch to the correct SCSI ID for your configuration. The switch settings should emulate the jumper positions shown in Figure 3.

Note: For specific information about pin assignments for the SCSI ID jumper block, refer to the *EXB-8500 and EXB-8500c Product Specification*.

Preparing the Tape Drive for the SCSI Bus

The SCSI bus that you attach the tape drive to must be terminated correctly to ensure proper operation. The devices that are physically located at each end of the SCSI cable must have terminators installed. All other devices on the SCSI cable must not have terminators installed.

If the tape drive will be located at the end of the SCSI bus, you must terminate the tape drive. The procedure you use depends on whether the tape drive uses a single-ended or a differential SCSI configuration.

Terminating a Single-Ended Tape Drive

The single-ended tape drive includes two single in-line package resistor terminators (R-packs) that can be left in place if the tape drive terminates the SCSI bus.

CAUTION

The R-packs must be removed if the tape drive does not terminate the SCSI bus or if you plan to use an external SCSI bus termination.

Optional External Termination

If desired, you can terminate the single-ended tape drive externally by removing the R-packs from the back of the tape drive and installing an external terminator. Exabyte recommends a Methode Electronics, Inc. dataMate DM103-02-0 single-ended external terminator.

Removing the R-Packs

To remove the R-packs, follow these steps:

1. Locate the two R-packs on the back of the tape drive, as shown in Figure 4.

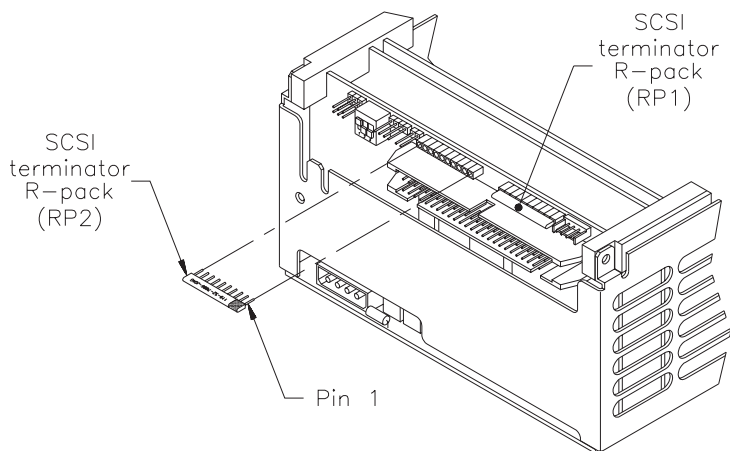

Figure 4 Location of R-packs (single-ended configuration)

2. Using a pair of flat-nose wiring pliers, grasp each R-pack at the center and pull it straight out. Be careful not to squeeze the pliers too tightly or you may break the R-pack.

Replacing the R-Packs

If you need to put the R-packs back in the tape drive, make sure that pin 1 of each R-pack is aligned with pin 1 of the socket and that no pins are bent. As shown in Figure 4, the writing on the R-pack should face upward. Pin 1 of the R-pack is marked with a colored line or dot and should line up with the right side of the socket.

CAUTION

If you replace an R-pack, be sure to use the correct type to avoid damaging the tape drive. The tape drive uses two 10-pin, 9-resistor R-pack terminators, rated at 110 ohms. Replacement R-packs are available from Exabyte (part number 002228).

Terminating a Differential Tape Drive

The differential tape drive does not include internal terminators. If a differential tape drive terminates the SCSI bus, it must be terminated externally. See page 9 for information about the recommended terminator.

Connecting the SCSI Cable

The tape drive uses a standard 50-pin single-ended SCSI cable connector. Push the keyed connector on the SCSI cable on to the SCSI connector on the back of the tape drive. The connector is keyed so that it can be connected only one way.

Figure 5 shows the location of the SCSI connector.

Note: The SCSI cable for connecting the tape drive to the host is not provided with the tape drive. Refer to page 37 for information about the requirements for the SCSI cable.

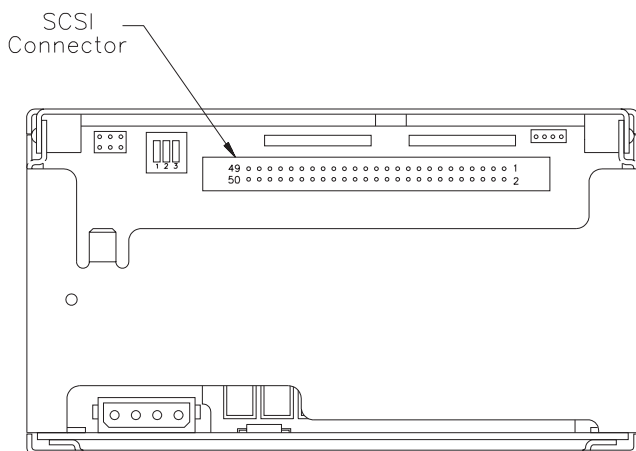

Figure 5 Location of SCSI connector

Installing the Tape Drive in a PC Drive Bay

If you are planning to mount the tape drive in a full-high PC drive bay, follow the guidelines in this section. Otherwise, refer to Appendix A for installation requirements, then resume reading on page 20, "Performing the Initial Power On."

Before beginning, prepare your computer as follows:

1. Turn off the computer and attached devices.
2. Unplug the power cord.
3. Remove the computer's cover as described in your computer owner's manual.
4. Remove the cover plate(s) from the drive bay(s) you intend to use. Refer to your computer owner's manual for instructions.

Note: For some computers you may need to use two half-high drive bays to accommodate the tape drive.

5. If necessary, remove one of the floppy disk drives to provide an empty full-high drive bay for the tape drive.

CAUTION

If you remove floppy disk drive B to install the tape drive, be sure to change your system configuration to reflect this. Refer to your computer owner's manual for details on running the system's setup program.

Mounting Procedure

Follow these steps to mount the tape drive:

1. Check for the presence of a load resistor in the computer. If it is present, disconnect the load resistor cable from the power supply. Refer to your computer owner's manual for more information.
2. Use #6 3/32 screws to attach two slide rails to the sides of the tape drive (see Figure 6). The tapered end of each rail should point toward the rear of the tape drive.

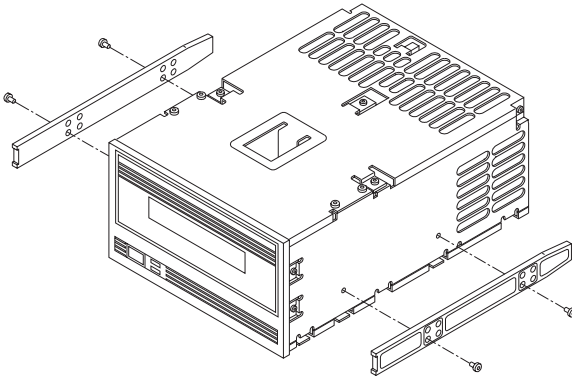

Figure 6 Attaching the slide rails to the tape drive

3. From the front of the computer, thread the SCSI cable into the computer through the open bay. Slide the tape drive into the bay until the faceplate is flush with the front of the bay.
4. Secure the tape drive to the drive bay as instructed in your computer owner's manual.
5. Connect the SCSI cable to your SCSI adapter card (see Figure 7).

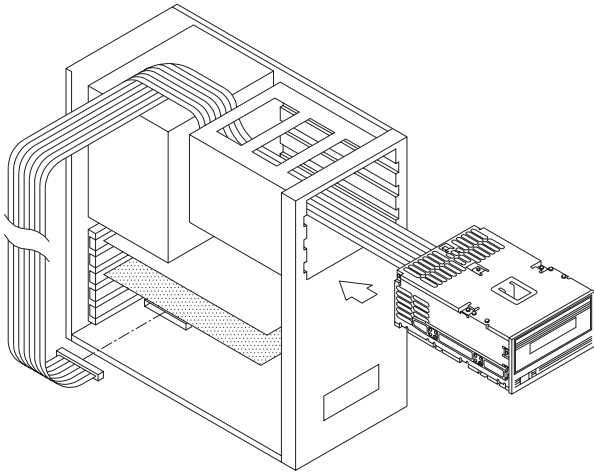

Figure 7 Inserting the drive into the drive bay and connecting the SCSI cable to the SCSI

6. If you need additional chassis grounding, connect a grounding wire fitted with a $\frac{1}{4}$ -inch female spade connector to the ground tab on the back of the tape drive. Or, use an M3-0.5 6 mm self-tapping screw to connect the wire to the grounding hole. The ground tab and grounding hole are shown in Figure 8.

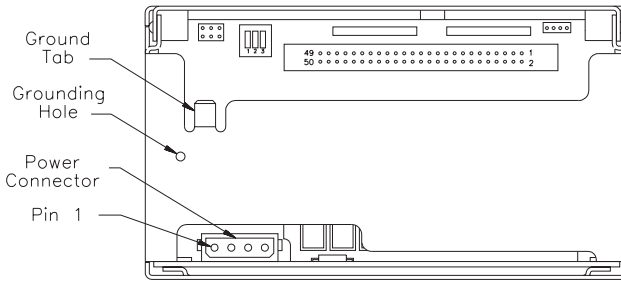

Figure 8 Location of grounding tab, grounding hole, and power connector

7. Connect power cable from the power supply to the 4-pin power connector on the back of the tape drive.

CAUTION

- Make sure that the PC power is off before you connect the cable.
- Do not force the plug into the connector. The keyed edges of the plug and the connector must match.

8. Replace the computer's cover.

Performing the Initial Power On

The procedure you use to perform the initial power on depends on how long the tape drive has been stored. If you are not sure how long the tape drive has been stored, check the MLCH (machine level control history) label on the top of the tape drive to find out when the tape drive was manufactured. Although the tape drive may have been operated since it was manufactured, for the purpose of the initial power on, assume that it has been stored throughout this period.

Tape Drive Stored for Less Than Six Months

If the tape drive has been stored for less than six months, the only step you need to perform for the initial power-on is to apply power to the tape drive.

When power is applied, the tape drive performs its power-on initialization and self-test (POST). Assuming that no data cartridge is loaded and that the tape drive is connected correctly, POST takes about 65 seconds, as follows:

- During the first part of POST, both the amber and green LEDs are lit.
- During the second part of POST, various combinations of the LEDs may be lit, depending on whether the tape drive is connected to the SCSI bus and whether a data cartridge is loaded.
- After the power-on initialization and self-test have completed, both LEDs will be turned off if there is no data cartridge loaded. If a data cartridge is loaded, the green LED will remain on.

Important

If the amber LED does not go out after the power-on initialization and self-test are complete, an error has occurred. Contact your vendor.

When POST completes, the tape drive is ready for normal operation.

Tape Drive Stored for Six Months or More

If the tape drive has been stored for six months or more, perform the following steps using your backup software to ensure that the tape drive's internal lubrication is properly distributed:

1. Apply power to the tape drive. The tape drive performs its POST as on page 20.
2. Locate a data cartridge that does not contain any valuable information. Set the write-protect switch to write enabled (see page 26).
3. Press the unload button on the front of the tape drive. Insert the data cartridge with the label side up and the write-protect switch facing you.

4. Push the door shut and wait while the tape drive loads the tape and positions it at LBOT. When the amber LED is off and the green LED is on, the tape is loaded and the tape drive is ready.
5. Write approximately 500 MBytes of data to the tape.
6. Read the data written in step 5.
7. Repeat steps 5 and 6 at least two times or for two hours (whichever is greater).

Note: If errors occur, reset the tape drive and repeat steps 5 through 7 as appropriate. If the error recurs, contact your vendor.

When you have completed step 7, the tape drive is ready for normal operation.

2 Operating the Tape Drive

This section includes information about the following:

- Reading the tape drive's LEDs
- Setting the write-protect switch on the data cartridge
- Loading and unloading a data cartridge

Figure 9 shows the controls and indicators on the front panel of the EXB-8500c. (The front panel of the EXB-8500 is the same except that it has no "c" on the unload button.)

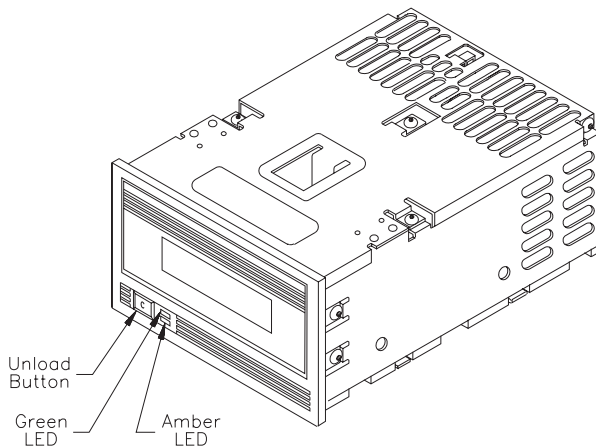

Figure 9 Unload button and LEDs

Reading the LEDs

The tape drive uses two LEDs to indicate its operating states. The LEDs indicate the following general conditions:

- The green LED indicates that the tape drive can accept a tape access command.
- The amber LED indicates SCSI bus activity and tape drive error conditions

Table 2 shows specific combinations of LEDs that may occur during tape drive operation. You may occasionally observe LED combinations and sequences not described in Table 2. These other combinations represent special or unusual conditions that are beyond the scope of this table. (For example, a fairly complex LED sequence occurs when you load new microcode from tape.)

Table 2 Tape drive states indicated by the LEDs

Tape Drive State	LEDs (■ = On □ = Off † = Flashing ^a)	
	Amber LED	Green LED
POST ^b	■	■
POST (passed) ^c	□	□
Ready (tape loaded)	□	■
Normal tape motion	■ or □ ^d	slow †
High-speed search/rewind		fast †
Servo error ^e	■ or □ or †	four †s then □
CRC fail ^f	slow †	■ or □
Unrecoverable fault ^f		
Failed POST	fast †	□
Unload button fail		■ or □

^a Slow flash = 1 flash/second (0.94 Hz).

Fast flash = 4 flashes/second (3.76 Hz).

^b The tape drive is performing power-on self-test diagnostics. This takes about 65 seconds.

^c The green LED may go off before the amber LED if no tape is loaded.

^d The amber LED is on (■) during data transfer over the SCSI bus. The amber LED is off (□) when no data transfer is occurring. The combination of on and off may appear as an irregular flash.

^e Refer to page 27 for information about clearing servo errors.

^f CRC failures occur only within the first two seconds after a power-on reset. An unrecoverable fault can occur anytime during operation.

Selecting Data Cartridges

By selecting high-quality data cartridges and storing them properly, you can expect a long shelf-life and optimal data integrity from them. High quality tapes also help maintain tape drive reliability by minimizing wear on the recording heads.

Choosing High-Quality Data Cartridges

Available from Exabyte, EXATAPE™ 8mm Data Cartridges are formulated specifically for use in Exabyte products. EXATAPE data cartridges reduce head and tape path wear and have a shelf life exceeding 30 years when used according to recommendations. Available in three sizes (112m, 54m, and 15m), **EXATAPE data cartridges are the only data cartridges recommended for use with all Exabyte products.**

CAUTION

Exabyte strongly recommends that you use EXATAPE data-grade metal-particle media in the tape drive.

Never use video-grade tape for data storage. Video-grade tape can be less accurate than data-grade tape when recording high-density data and more abrasive to tape drive recording heads. In particular, **Exabyte strongly discourages use of the following types of video-grade tapes:**

- ✗ “Extended length” (such as 135-, 140-, and 150-minute tapes)
- ✗ Hi-8 metal particle (MP), metal evaporative (ME), or barium ferrite (BaFe) tapes. These tapes will be ejected automatically by the tape drive.

Setting the Write-Protect Switch

EXATAPE™ 8mm data cartridges are equipped with a write-protect switch, shown in Figure 10, to prevent data on the tape from being unintentionally overwritten. Before loading a data cartridge in the tape drive, ensure that the write-protect switch is set correctly for the desired operation. You can use a ball-point pen or similar instrument to set the write-protect switch as follows:

- **To write protect the data cartridge**, move the write-protect switch away from the edge of the data cartridge. If the red tab is visible, the cartridge is write protected and cannot be written to or erased.
- **To write enable the data cartridge**, move the write-protect switch toward the edge of the data cartridge. If the red tab is not visible, the data cartridge is write enabled and can be written to or erased.

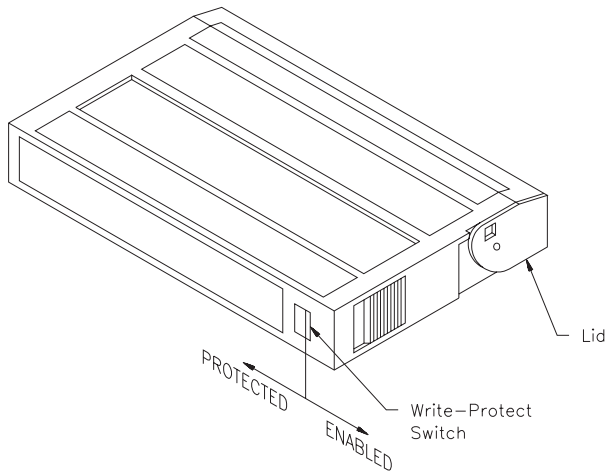

Figure 10 Write-protect switch on an EXATAPE 8mm data cartridge

Loading a Data Cartridge

To load a data cartridge into the tape drive, follow these steps:

1. Ensure that the write-protect switch has been set correctly for the desired operation, as explained on page 26.
2. If you have just powered on the tape drive, be sure that the green LED is off, indicating that the tape drive has passed its power-on self-test and is ready to load the data cartridge.
3. If necessary, press the unload button to open the door on the tape drive.
4. Insert the data cartridge into the tape drive with the label side up and the write-protect switch facing you.
5. Gently close the door. The tape drive automatically loads the data cartridge and indicates ready status (green LED on).

Note: Most tape drives load the data cartridge automatically. However, your application software may disable the autoload function. If the data cartridge does not go to the ready state after you close the door, consult your software documentation for information.

Unloading a Data Cartridge

Unload Button

The unload button is the only operator control on the tape drive. It is used to unload the tape from the tape drive.

The unload button can also be used to clear servo and other errors. If a servo or hardware error occurs, press the unload button to reset the tape drive. Then, if necessary,

wait a few seconds and press the button again to eject the tape.

To unload a data cartridge, press the unload button on the tape drive's front panel. The tape drive completes the current operation, writes any buffered data to tape, unloads the tape from the tape path, and ejects the cartridge.

Note: Some tape drives are configured to eject the tape immediately when the unload button is pressed. Refer to the *EXB-8500 and EXB-8500c Product Specification* if you have a tape drive configured in this way.

Error During Unload Procedure

If an error exists before or during the unload procedure, the unload sequence will be suspended and the amber LED will flash. If the unload button is pressed again, the unload sequence will be reattempted; however, unwritten data in the buffer will not be written to tape. The buffer and errors will be cleared.

3 Preventive Maintenance

The only routine maintenance required by the tape drive is regular cleaning of the tape drive heads and tape path. Use only an Exabyte or Exabyte-approved 8mm Cleaning Cartridge. Proper storage and maintenance of your data cartridges will maximize the shelf life of your tapes and assure data integrity.

Important

Using a cleaning method other than the Exabyte 8mm Cleaning Cartridge or an Exabyte-approved cleaning cartridge will void the warranty for the tape drive and can lead to premature head wear.

Determining When to Clean the Tape Drive

You should clean the tape drive's heads and tape path after **every 30 tape motion hours**. This cleaning frequency is independent of the format in which you write and read data. However, if you are using the tape drive in a particularly dirty environment, or if you operate it infrequently, you may want to clean the tape drive more often than every 30 tape motion hours.

Some backup software programs may notify you when the tape drive needs cleaning. Refer to the documentation for your backup software for more information.

Note: The tape drive keeps track of its tape motion hours internally. To determine when the tape drive needs to be cleaned, issue a REQUEST SENSE (03h) command and look at the setting of the CLN and CLND bits (byte 21, bits 3 and 4). If the CLN bit is set to 1, the tape drive needs to be cleaned. This bit is reset to 0 when you perform a successful cleaning cycle. The CLND bit is set to 1 when the tape drive has been cleaned and is reset to 0 when the next REQUEST SENSE command is received.

Using the 8mm Cleaning Cartridge

CAUTION

To prevent contamination of the tape drive and damage to the heads, **do not use the cleaning cartridge for more than the number of cleaning cycles specified on the cartridge label.** Reusing the material in the cleaning cartridge will redistribute contaminants previously removed from the tape path. Discard the cleaning cartridge after you have used it for the specified number of cleaning cycles.

To use the cleaning cartridge, follow these steps:

1. Apply power to the tape drive. When the power-on self-test is complete, press the unload button and remove any data cartridge from the tape drive.
2. Check the usage record on the label of the cleaning cartridge to make sure that there is at least one cleaning cycle remaining (see Figure 11). If there are no cleaning cycles remaining, discard the cleaning cartridge and use a new one.

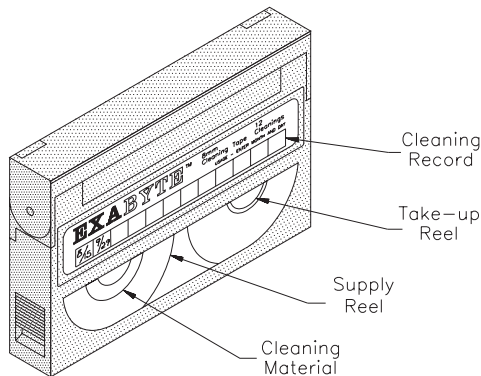

Figure 11 Exabyte 8mm Cleaning Cartridge with label showing cleaning cycles left

3. Insert the cleaning cartridge in the tape drive and close the door.
4. The cleaning cycle is performed automatically by the tape drive and takes approximately 38 seconds. When the cleaning cycle is complete, the cleaning cartridge is automatically unloaded and ejected from the tape drive.

Important

If there are no more cleaning cycles remaining for the cleaning cartridge, the tape drive ejects it without completing the cleaning cycle.

Note: To confirm that a cleaning was done, issue a REQUEST SENSE (03h) command and check the setting of the CLND bit. If set to 1, this bit indicates that the cleaning was successful. A setting of 0 indicates that the cleaning was not done.

5. If the cleaning cycle was successful, record the date the cleaning was performed on the cleaning cartridge label. Store the cleaning cartridge for future use if it still has cycles remaining. Or, discard it if no more cleaning cycles remain.

Caring for Data Cartridges

To maximize the shelf life of your tapes and assure data integrity, follow these guidelines when storing data cartridges:

- **Place a label or other reference information on the cartridge adjacent to the write-protect switch.**
- **Store cartridges in a cool, non-magnetic environment.** Follow the cartridge manufacturer's specifications for storage temperature and other environmental requirements. Do not allow the temperature and humidity in the storage environment to fluctuate.

- **Keep the storage location as free of airborne particulates as possible.** To eliminate obvious sources of particulates, do not permit anyone to smoke, eat, or drink near the storage area, and do not store cartridges near a copier or printer that may emit toner and paper dust.
- **Store data cartridges as soon as possible after you have written data to them.** Immediate storage helps avoid many of the conditions that can damage tapes, such as temperature and humidity fluctuation, particulate contamination, and excessive handling.
- **Store data cartridges with the write-protect switch in the protected position.** See page 26.
- **Store each cartridge on one of its long edges, not flat on its side (see Figure 12).** When a data cartridge is stored on its side, the tape inside the cartridge is actually on its edge. In this position, stress is placed on the tape edges and can lead to tape damage. For the same reason, never stack cartridges on top of each other or lean them at an angle for extended periods of time.

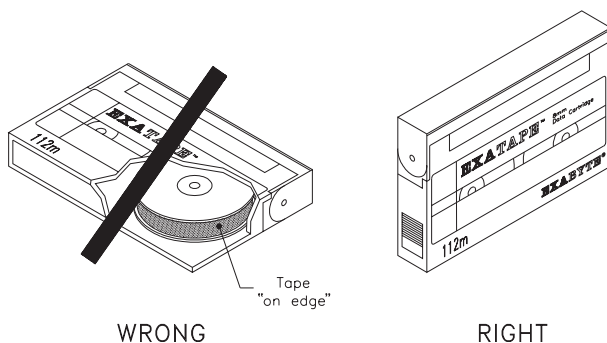

Figure 12 Do not store a data cartridge on its side

Replacing Data Cartridges

Approximately once each year, you may want to run each tape through a full pass and check its error statistics. If errors have increased significantly since the previous test or if they exceed a certain predetermined threshold, you should re-archive the data to a new tape and discard the old tape.

Notes:

4 Packing the Tape Drive

You can ship the tape drive with either one drive per carton (single-pack) or with four drives per carton (four-pack). Figure 13 on page 34 shows the single-pack carton and packing materials.

CAUTION

- To avoid damaging the tape drive and voiding your warranty, be sure to use the original shipping materials (or replacement materials obtained from Exabyte) when repacking and shipping the tape drive.
- To ensure that the packaging meets the required specifications, do not modify the packaging in any way. The shipping carton and packing materials are not intended to be used for shipping items other than or in addition to a tape drive.

Table 3 shows the dimensions and weights of the single-pack and four-pack shipping cartons.

Table 3 Dimensions and weights of CTS shipping cartons

Size	Dimensions	Weight (with tape drive)
Single-pack	34.3 cm long 27.3 cm wide 22.2 cm high (13.5 10.75 8.75 inches)	1 tape drive: 3.6 kg (8.0 lbs)
Four-pack	58.4 cm long 34.9 cm wide 29.8 cm high (23.0 13.75 11.75 inches)	4 tape drives: 10.4 kg (23.0 lbs)

Packing the Tape Drive for Shipment

To pack the tape drive for shipment, follow these steps:

1. Obtain the original shipping carton or contact your vendor to receive a new one.
2. Assemble the carton and tape it shut at the bottom with two-inch (51 mm) packing tape.
3. Place each tape drive in an antistatic bag. Tape the bag shut.
4. Place the bottom packing cushion in the carton, with the fitted area for the tape drive or tape drives facing up.
5. **Single-pack shipping carton (Figure 13):**
 - a. Place the tape drive into the fitted area in the packing cushion.
 - b. Place the top packing cushion over the tape drive, with the cardboard side facing down.

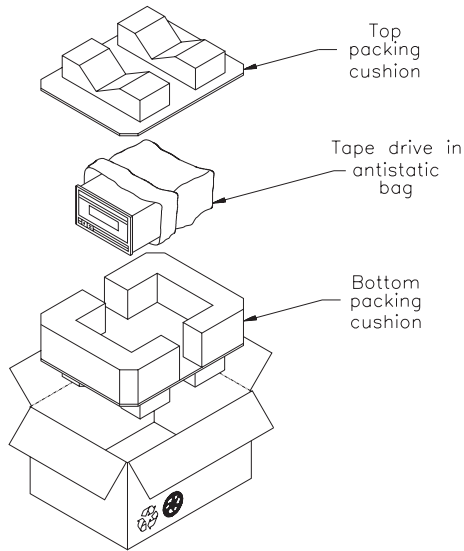

Figure 13 Single-pack carton and packing materials

6. Four-pack shipping carton:

CAUTION

Do not use the four-pack shipping carton for fewer than four tape drives. If you are shipping one, two, or three tape drives, use a single-pack carton for each tape drive.

- a. Place four tape drives in the bottom packing cushion's slots. You can place the tape drives in the packing cushion so that either the front or rear panel faces up.
 - b. Place the top packing cushion over the tape drives.
7. Close the carton and tape the top seam so that the carton is completely closed.

Environmental Requirements for Shipment

When shipping a tape drive, be sure to comply with the environmental specifications shown in Table 4.

Table 4 Environmental specifications for shipping the tape drive

Temp. Range	-40° C to +60° C (-40° F to +140° F)
Temp. Variation	1° C per minute up to a maximum of 20° C per hour (2° F per minute up to a maximum of 36° F per hour)
Rel. Humidity	10% to 90% non-condensing
Wet Bulb	26° C max (79° F max)
Altitude	-304.8 m to +12,192 m (-1,000 ft to +40,000 ft)

Appendix A Installation Requirements

This appendix provides specific installation requirements for the tape drive. It also provides guidelines for the following tasks:

- Selecting the correct SCSI cable and connector (pages 37 and 38)
- Attaching the tape drive to a frame (page 38)
- Providing chassis grounding (page 40)
- Connecting the tape drive to the power supply (page 40)

If you have already installed the tape drive in a PC, you can skip this appendix.

SCSI Cable Requirements

The SCSI cable for connecting the tape drive to the host is not provided with the tape drive. You must provide a cable that complies with the appropriate safety and regulatory agency requirements. To comply with FCC, Canadian DOC, and VDE limits, the tape drive requires shielded cables when the cables are external to the mounting enclosure.

General Requirements

Use a 50-conductor flat cable or 25-signal twisted pair cable. A minimum conductor size of 28 AWG is recommended to minimize noise effects and ensure proper distribution of terminator power.

Ideally, to match the cable terminators, the cable should have a characteristic impedance of 122 ohms (differential) or 132 ohms (single-ended). However, since cables with this high of a characteristic impedance are not generally available, somewhat lower impedances are acceptable. A characteristic impedance of 100 ohms \pm 10% is recommended for unshielded flat or twisted-pair ribbon cable. A characteristic impedance greater than 90 ohms is recommended for shielded cables.

Note: To minimize discontinuities and signal reflections, ensure that cables used on the same bus have the same impedances.

Cable Length Requirements for Differential Configurations

For differential SCSI configurations, ensure that the sum of all the SCSI cable lengths does not exceed 25.0 meters (82.02 feet). A stub length of no more than 0.2 meters (8 inches) is allowed off the mainline interconnection within any connected equipment. The stub length within the tape drive is less than 50 mm (1.97 inches).

Cable Length Requirements for Single-Ended Configurations

For single-ended SCSI configurations, ensure that the sum of all the SCSI cable lengths does not exceed 6.0 meters (19.68 feet). A stub length of no more than 0.1 meters (4 inches) is allowed off the mainline interconnection within any connected equipment. The stub length within the tape drive is less than 50 mm (1.97 inches).

SCSI Cable Connector

To connect the tape drive to the SCSI bus, use a 50-pin female ribbon cable connector (AMP™ No. 1-746285-0 or equivalent). The tape drive's SCSI connector is located at the rear of the tape drive. The connector is a 50-pin male ribbon cable connector, consisting of two rows of 25 pins with adjacent pins 2.54 mm (0.1 inch) apart. For information about the specific SCSI connector pin assignments for differential and single-ended tape drives, refer to the *EXB-8500 and EXB-8500c Product Specification*.

Attaching the Tape Drive to a Frame

The main housing of the tape drive includes two sets of mounting holes (one set on the sides and one set on the bottom, as shown in Figures 14 and 15) to allow for a number of mounting positions. These mounting holes accommodate #6-32 screws. Refer to the *EXB-8500 and*

EXB-8500c Product Specification for detailed information about the spacing of these mounting holes.

When mounting the tape drive, follow these guidelines:

- The mounting location must meet the environmental requirements discussed in the *EXB-8500 and EXB-8500c Product Specification*. These requirements specify limits for operating temperature, humidity, airflow, particulate contamination, shock, and vibration.
- The tape drive must be mounted solidly and securely. To assure reliability, there must be no distortion of the tape drive's metal housing. Do not install the tape drive in such a way that its frame is unsupported. For example, do not hang the tape drive by an edge.
- Use either the four mounting holes on the sides or the four mounting holes on the bottom ("A" or "B," as shown in Figures 14 and 15). Using combinations of mounting holes from different sets may distort the frame.
- Objects such as screw heads, cables, or adjacent devices must not press against the frame of the tape drive.
- The ventilation slots at the sides and top of the tape drive must be free of obstruction so that adequate airflow is provided.
- There must be sufficient space to access and operate the front panel controls.

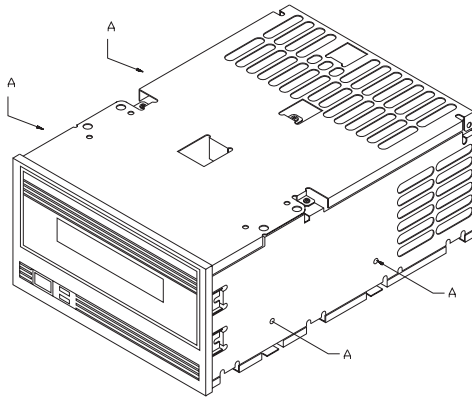

Figure 14 Mounting holes on the sides of the tape drive

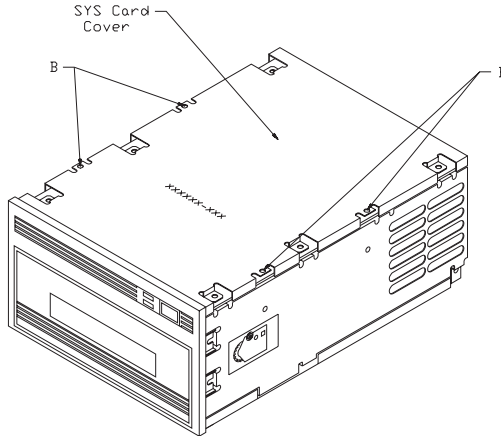

Figure 15 Mounting holes on the bottom of the tape drive

Chassis Grounding (optional)

If additional chassis grounding is desired, connect a 1/4-inch female spade connector to the ground tab at the rear of the tape drive. Or, connect an M3-0.5 6 mm self-tapping screw to the grounding hole. The ground tab and grounding hole are shown in Figure 8 on page 19.

Note: The power supply returns are connected to the chassis, so you cannot isolate logic common ground from chassis ground.

Power Cable Connector

The tape drive operates from standard +5 VDC and +12 VDC supply voltages; it cannot use external AC power. Safety agency certification requires that the supplied voltage be from a Safety Extra-Low Voltage source (per IEC 950). Refer to Appendix B for tape drive power specifications.

CAUTION

The tape drive does not provide any overvoltage or over current protection. For this reason, be certain that the power is off before connecting the tape drive to a power supply.

The power connector used in the tape drive is compatible with power connectors used for standard 5.25-inch devices. To connect the tape drive to a power cable, use an AMP 1-480424-0 series or equivalent female connector. For information about the specific power connector pin assignments, refer to the *EXB-8500 and EXB-8500c Product Specification*.

Notes:

Appendix B Tape Drive Specifications

General

Front panel	Unload button, LED indicators for SCSI activity, tape motion, and errors
Back panel	SCSI cable connector, power connector, jumper block and DIP switch for SCSI ID, SCSI terminator R-packs (single-ended configuration)
Interface	SCSI-1 and SCSI-2, single-ended or differential

Physical Characteristics

Form factor	5.25-inch full-high
Size	82.5 mm (3.25 inches) high 146.0 mm (5.75 inches) wide 203.2 mm (8.0 inches) deep
Weight	1.2 kilograms (2.6 pounds)

Environmental

Operating temperature	+5°C to +40°C (+41°F to +104°F)
Non-operating temperature	-40°C to +60°C (-40°F to +140°F)
Operating rel. humidity	20% to 80%
Non-operating rel. humidity	10% to 90%

Sustained Data Transfer Rate

8200 format	262.5 KBytes/sec
8200c^a format (EXB-8500c)	500 KBytes/sec
8500 format	500 KBytes/sec
8500c^a format (EXB-8500c)	1 MByte/sec

Capacity of EXATAPE 112m Data Cartridge

8200 format	2.5 GBytes
8200c^a format (EXB-8500c)	5.0 GBytes
8500 format	5.0 GBytes
8500c^a format (EXB-8500c)	10.0 GBytes

Power and Reliability

Supply voltages	Standard +5 VDC and +12 VDC ±5%
Tolerance	125 mVpp max. ^b
Maximum current	2.09 Amps at +5 VDC; 0.75 Amps at +12 VDC
Maximum power consumption	10.45 watts at +5 VDC; 9.1 watts at +12 VDC
Mean time between failure	40,000 hours @ 10% duty cycle

^a Assuming an average compression ratio of 2:1.

^b The ripple voltage is included in the total voltage tolerance.

Notes:

Index

A

agency standards 3

C

cable requirements

power cable 40

SCSI cable 37 – 38

cartridges

see data cartridges

chassis grounding 19, 40

cleaning the tape drive

frequency 29

instructions 30 – 31

condensation 10

D

data cartridges

care of 31 – 32

loading 27

replacing 32

storing 31 – 32

unloading 27 – 28

write-protect switch 26

differential SCSI

cable requirements 38

termination 9, 16

DIP switches for setting SCSI ID 12

E

electrostatic discharge 10

EXATAPE 8mm Data Cartridge 25

G

grounding, chassis 19, 40

H

handling the tape drive 10

I

installation

attaching to a frame 38 – 39

cable requirements 37 – 38

connecting the power supply 20

connecting to the SCSI bus 14, 16

grounding 19, 40

power cable requirements 40

setting the SCSI ID 11

J

jumpers for setting SCSI ID 13

L

LEDs

location 23

states indicated by 23 – 24

load procedure 27

M

maintenance

see preventative maintenance

mounting requirements 38 – 39

O

operating the tape drive 23 – 24, 27 – 28

P

packing the tape drive 33 – 35

power cable requirements 40

power supply

connecting tape drive to 20, 40

preventive maintenance 29 – 31

R

R-packs 15 – 16

remote switch for setting SCSI ID 14

resistor terminators 15 – 16

S

SCSI bus

cable requirements 37 – 38

connecting the tape drive to 14, 16

differential SCSI 38

single-ended SCSI 38

stub length 38

termination 9, 15 – 16

SCSI ID

requirements for setting 11

setting with DIP switch 12

setting with jumpers 13

setting with remote switch 14

shipping the tape drive 33 – 35

single-ended SCSI

cable requirements 38

termination 15 – 16

T

tape drive

cleaning 29 – 31

controls and indicators 23 – 24

installation 9 – 21, 38 – 40

loading a data cartridge 27

packing and shipping 33 – 35

providing chassis grounding 19

unloading a data cartridge 27 – 28

unpacking 10

terminators for SCSI bus 9, 15 – 16

U

unload button

location 23

operation 27

unload procedure 27 – 28

unpacking instructions 10

W

write-protect switch 26

Exabyte Corporation
1685 38th Street
Boulder, Colorado USA 80301



Free Manuals Download Website

<http://myh66.com>

<http://usermanuals.us>

<http://www.somanuals.com>

<http://www.4manuals.cc>

<http://www.manual-lib.com>

<http://www.404manual.com>

<http://www.luxmanual.com>

<http://aubethermostatmanual.com>

Golf course search by state

<http://golfingnear.com>

Email search by domain

<http://emailbydomain.com>

Auto manuals search

<http://auto.somanuals.com>

TV manuals search

<http://tv.somanuals.com>